

PROJECT DATA SHEET

PROJECT: PROPOSED CONSTRUCTION OF ALUPE UNIVERSITY SDHUD STUDENT’S ACCOMMODATION, BUSIA TOWN , BUSIA COUNTY, WITH INFRASTRUCTURE WORKS			
Item	DETAILS OF SITE	PROJECT PARTICULARS	DETAILED PROJECT INFORMATION
1	Tender No	MLPWHUD/SDHUD/AHP/342/2023-2024	
2	Site location	Busia Town, Busia County	
3	Site conditions		
4	Land Size	Approximately 1Acre	
5	Scope	676 No. Of Units in 2No of blocks distributed as follows 2No. Blocks Of Type G+9 Blocks 338 No. Of Units in each	160 No. Of Quad beds units 120 No. of Studios units 58 No. of single units
6	Auxiliary Facilities	Student lounge and kitchenette within block design, Student Centre, and a basketball pitch	
7	External works	Civil works, Boundary wall, Guard House, Garbage Receptacles, Swimming pool with associated changing rooms	
8	Built area	27,863 sqm	

PRELIMINARIES

ITEM	DESCRIPTION	AMOUNT
A	<p><u>BILL NO. 1</u></p> <p><u>PARTICULAR PRELIMINARIES</u></p> <p><u>PARTIES</u></p> <p>The Employer is:</p> <p>Principal Secretary, Ministry of Lands, Public works,Housing and Urban Development, State Department of Housing and Urban Development P.O Box 30119 -00100 NAIROBI, KENYA</p> <p>The Engineer is: The term "PM" wherever used in these Bills of Quantities shall be deemed to imply the Engineer as defined in Condition 1 of the Conditions of Contract or such person or persons as may be duly authorised to represent him on behalf of the Government .</p> <p>The Architect is: Ministry of Lands, Public works,Housing and Urban Development, State Department of Housing and Urban Development P.O Box 30119 -00100 NAIROBI, KENYA</p> <p>The Quantity Surveyors is: Ministry of Lands, Public works,Housing and Urban Development, State Department of Housing and Urban Development P.O Box 30119 -00100 NAIROBI, KENYA</p> <p>The Structural/ Civil Engineers is: Ministry of Lands, Public works,Housing and Urban Development, State Department of Housing and Urban Development P.O Box 30119 -00100 NAIROBI, KENYA</p> <p>The Electrical / Mechanical Engineers is: Ministry of Lands, Public works,Housing and Urban Development, State Department of Housing and Urban Development P.O Box 30119 -00100 NAIROBI, KENYA</p>	

ITEM	DESCRIPTION	AMOUNT
A	<p><u>LOCATION OF SITE</u></p> <p>The site of the proposed works is located Alupe, Nyanza County The Contractor shall be deemed to have visited the site and satisfied himself as to:-</p> <p>a) The nature, position, topography and access of the site b) The amount of the rubbish or debris to be cleared away before commencement. c) The nature, current usage, proximity and size of adjoining property and buildings d) The availability of land for the erection and positioning of all temporary structures, plant and materials necessary for the execution of the works.</p> <p>The Contractor shall obtain approval from the relevant Local Authority in adherence to site access and erection of temporary structures and must ensure all matters relating to the requirements of these authorities.</p> <p>No claim will be allowed for travelling or other expenses which may be incurred by the Contractor in visiting the site or preparing the tender for the works.</p>	
B	<p><u>EXISTING SITE CONDITIONS</u></p> <p>The site for the proposed works isAlupe , Nyanza County</p> <p>The Contractor is advised to visit the site before hand to familiarise with the site conditions.</p> <p>All occupation health and safety requirements must be met as required by law.</p> <p>This includes prevention and or minimizing noise, dust, fumes e.t.c.</p> <p>Notices should be given prior to disruption of services</p>	
C	<p><u>PROJECT DATA</u></p> <p>The Works under this contract comprises of the following;</p> <p>(a) 2 No Type A Hostel Block with a plinth area of 24,684SM (b) Waste receptacle Plinth area 14 SM (c) Commercial center Plinth area 430 SM (d) 2 No Guard House Plinth area 20 SM (e) Basket Ball Pitch 574 Sm (f) Boundary wall - 2.4m high with a length of 500LM (g) Road works -3540 SM (h) Associated electrical and Mechanical works (i) External and Civil works</p> <p>Carried to collection</p>	

ITEM	DESCRIPTION	AMOUNT
A	<p><u>DESCRIPTION OF THE WORKS</u></p> <p>The construction comprises reinforced concrete foundations, masonry walling, reinforced concrete beams, column , staircases and suspended solid slabs, roof construction.</p> <p>The exterior facade consists of steel casement windows, steel and timber doors , render and paint finish, clay and stone facing finish to walls</p> <p>The interior works includes timber doors and finishes which are generally plaster and paint to walls, ceramic and non slip ceramic tiles to floors and walls.</p> <p>External works generally comprise of foul water drainage, storm water drainage, pathway, dryline area, septic tank, underground water tank.</p> <p>All mechanical / electrical services and other specialist works associated with the above works shall be executed by domestic/nominated sub contractors approved by the Engineer</p> <p><u>CONTRACT PARTICULARS</u></p> <p>B <u>FORM OF CONTRACT</u></p> <p>The Contractor will be required to enter into a contract with the Employer under the Terms and Conditions of Contract as "Standard Tender Document for Procurement of Works (Building and Associated Civil Engineering Works) Issued by the Public Procurement Regulatory Authority in February 2021 (updated 2022) and in association with the latest applicable version of the Public Procurement and Asset Disposal Act.</p> <p>The Contractor's attention is called to the appendix of the conditions of Contract and additions and amendments thereto, which shall be read as incorporated herein and he shall allow any sums which he considers necessary for the observance of such conditions, together with sub clauses used in application.</p> <p>The priority of such documents shall be as stated in the conditions of agreement.</p> <p>Carried to collection</p>	

ITEM	DESCRIPTION	AMOUNT
A	<p><u>LIABILITY AGAINST INJURY TO PERSONS AND PROPERTY</u></p> <p>Insurance against injury to persons and property</p> <p>NOTES</p> <p>In addition to the conditions of the contract and the requirement contained herein the contractor's all risk policy shall cover the full value of the following and allow for all costs thereof:-</p> <ul style="list-style-type: none"> i) The works and temporary works erected in performance of this contract. ii) The materials on site, plant and tools iii) The cost and expense of removing debris of the property insured, destroyed or damaged by any peril insured. iv) Professional fees (to be allowed at 15% of the contract sum) v) Employer's liability (workman's compensation) ii) Third party (Public liability for an indemnity of not less than shs 5,000,000.00 for any accident or series of accidents arising from the same event (unlimited in aggregate) <p>The contractor shall ensure that all sub-contractors effect and maintain such insurances as are necessary to cover their liabilities in respect of injury to persons and property and workman,s compensation.</p> <p>Should the contractor already hold annual insurances covering the whole of his activities, and the indemnity required under the existing policy/ies then further insurances shall be effected and maintained to cover such excess, the policies of insurances being suitably endorsed to cover this project</p>	
B	<p><u>Insurance of the works (contractors liability)</u></p> <p>The Contractor shall insure as required in the Conditions of Contract. No payment on account of the work executed will be made to the Contractor until he has satisfied the Engineer either by production of an Insurance Policy or and Insurance Certificate that the provision of the foregoing Insurance Clauses have been complied with in all respects.</p> <p>Thereafter the Engineer shall from time to time ascertain that premiums are duly paid up by the Contractor who shall if called upon to do so, produce the receipted premium renewals for the Engineer's inspection.</p>	
	Carried to collection	

ITEM	DESCRIPTION	AMOUNT
	<p><u>PERFORMANCE BOND</u></p> <p>A Performance bond for the works</p> <p>The Contractor shall find and submit on the Form of Tender an approved bank or approved (By PPRA) Insurance Company and who will be willing to be bound to the Employer in an amount equal to ten percent (10%) of the Contract amount for the due performances of the Contract up to the date of completion as certified by the Engineer and who will when and if called upon, sign a Bond to that effect on the relevant standard form as seen in the CONTRACT STANDARD FORMS (without the addition of any limitations)</p> <p>And should the surety fail to be approved, the Contractor shall furnish within seven days another Surety to the approval of the Employer.</p> <p>Note that no payments on account of works executed will be made to the Contractor until he has submitted the Performance bond, duly stamped signed and sealed by an approved bank or insurance company.</p> <p>B <u>POSSESSION AND COMMENCEMENT</u></p> <p>The Contractor shall take possession of the site on the date indicated in the acceptance letter. The date of commencement of the works shall also be communicated to the Contractor and the contract period shall run from the commencement date.</p> <p>The Contractor is expected to utilize the period between possession and commencement to mobilise his resources to ensure smooth running of the works from the commencement date.</p> <p>Carried to collection</p>	

ITEM	DESCRIPTION	AMOUNT
	<p><u>PROJECT SUPERVISION</u></p> <p>A The said works shall be executed under the direction and to the entire satisfaction of the Engineer and Clerk of works who shall have the Engineer's specifically delegated authority and shall at all times have access to the works, to the yards and workshops of the contractor or other places where goods are being prepared for the building.</p> <p><u>LABOUR CAMPS</u></p> <p>B The contractor will generally not be permitted to house labour on site</p> <p><u>DOWNTAKINGS</u></p> <p>C All materials arising from demolitions and downtakings are deemed to be the property of the employer. No claim will be entertained on account of employer excising this right to retain the materials</p> <p>All downtakings shall be carefully removed, taken down, dismantled and stored on site until instructed by the Engineer to remove from the site. Such materials shall only be incorporated in the new works if required by the Engineer in which case appropriate adjustments will be made in the final account for the cost of labour, screws etc for fixing such downtakings in the new works.</p> <p><u>DAMAGES</u></p> <p>D Damages for delay in completion shall be levied at the rate of Kshs</p> <p>.....</p> <p>.....</p> <p><u>OTHER PRELIMINARIES</u></p> <p>E Allow for any other item necessary to execute the works and state them below;</p> <p>.....</p> <p>.....</p> <p>.....</p> <p>.....</p> <p>.....</p> <p>Carried to collection</p>	

ITEM	DESCRIPTION	AMOUNT
	<u>BILL NO. 1</u>	
	<u>PARTICULAR PRELIMINARIES</u>	
	<u>COLLECTION</u>	
	Carried from page 1/1	
	Carried from page 1/2	
	Carried from page 1/3	
	Carried from page 1/4	
	Carried from page 1/5	
	Carried from page 1/6	
	Particular Preliminaries Carried to Grand Summary	

ITEM	DESCRIPTION	AMOUNT
	<p><u>BILL NO. 2</u></p> <p><u>GENERAL PRELIMINARIES</u></p> <p><u>PRICING OF ITEMS OF PRELIMINARIES AND PREAMBLES</u></p> <p>A Whenever in the Contractor's priced Bills of Quantities no price appears against an item of Preliminaries or Preambles or work items , the value of such item shall be deemed to be included in his prices for other items in the Bills of Quantities.</p> <p><u>SUFFICIENCY OF TENDER</u></p> <p>B The Contractor shall be deemed to have satisfied himself before tendering as to the correctness and sufficiency of his tender for the works and of the rates and prices stated in the priced Bills of Quantities. Rates and prices quoted shall cover all his obligations under the contract and all the matters and maintenance of the works</p> <p><u>RECORDS</u></p> <p>C The Contractor shall ensure proper records are kept and maintained for : Daily Reports on Personnel and Machinery; tracked programme; weather charts/reports; site instruction book and query book,a digital camera shall be provided for taking progress photos</p> <p>The contractor shall be required to provide equipment for taking ground and aerial photos or videos in relation to the progress of works when called upon to do so.</p> <p><u>DEFINITIONS AND ABBREVIATIONS</u></p> <p>D Throughout these Bills, units of measurements and terms are abbreviated and shall be interpreted as follows:</p> <p>mm shall mean millimeter</p> <p>lm shall mean linear meter</p> <p>sm shall mean square meter</p> <p>m² shall mean square meter</p> <p>cm shall mean cubic meter</p> <p>kg shall mean kilogramme</p> <p>N shall mean Newton</p> <p>KN shall mean KiloNewton</p> <p>Carried to collection</p>	

ITEM	DESCRIPTION	AMOUNT
	<p>in/" shall mean inches</p> <p>L f shall mean linear foot</p> <p>s f shall mean square foot</p> <p>c f shall mean cubic foot</p> <p>L b shall mean pound avoirdupois</p> <p>No. shall mean number</p> <p>B.S. shall mean the current British Standard Specification published by the British Standard Institution, 2 Park Street, LONDON W.I, England.</p> <p>B.S.M shall mean both sides measured</p> <p>K.S. shall mean current Kenya Standard specification published by the Kenya Bureau of Standard, P.O. Box 54974. NAIROBI, Kenya.</p> <p>'As described' shall mean as described in these Bills of Quantities.</p> <p>'As before described' shall mean the whole of the previous description except as qualified in the current one.</p>	
	Carried to collection	

ITEM	DESCRIPTION	AMOUNT
	<p><u>SITE LEVELS</u></p> <p>A Before commencing work the Contractor must arrange for and agree with the Architect, Engineer and Quantity Surveyor the existing site levels and similarly establish and agree on a bench mark.</p> <p>The Contractor shall provide a surveyor to ensure all levels are achieved as per the drawings and Architects/Structural Engineer's instructions</p> <p><u>SETTING OUT</u></p> <p>B The contractor shall set out works in accordance with the dimensions and levels shown on the drawings and shall be responsible for the correctness of all dimensions and levels set out by him and he will be required to amend all errors arising from inaccurate setting out at his own cost and expenses. In the event of any error or discrepancy in the dimensions or levels marked on the drawings being discovered, such errors or discrepancies must be reported by the Contractor to the Engineer for his immediate attention.</p> <p>No work shall be commenced by the Contractor until he has received written instructions from the Engineer to adjust such discrepancies which may be proved, upon receipt of such instructions and no claim for extra expenses or relief from the provisions of Clause 5 of the Conditions of the Contract , any discrepancy or error in the dimensions or levels shown on the drawings may be made thereafter.</p> <p>The Contractor shall give the Engineer reasonable notice of the intention to set out or take levels for any part of the Works so that arrangements may be made for checking the work. The accuracy of setting out and leveling shall be within the tolerances specified in the Specifications or on the Drawings. The checking of setting out or leveling by the Engineer shall not relieve the Contractor of his duties or responsibilities under the Contract.</p> <p><u>MEASUREMENTS</u></p> <p>C Measurements are based on Standard Methods of Measurement of Building Works and Associated Civil Works For Eastern Africa (SMM) Second Edition 2008.</p> <p>In the event of any discrepancies arising between the Bills of Quantities and the actual works, the site measurements shall generally take precedence.</p> <p><u>GENERAL SPECIFICATIONS</u></p> <p>D All works to be carried out in accordance with the Ministry of Roads, public Works and Housing General Specifications for Building Works issued in 1976 or as qualified and amended.</p> <p>Carried to collection</p>	

ITEM	DESCRIPTION	AMOUNT
	<p><u>SAMPLES</u></p> <p>A The contractor shall furnish at the earliest possible opportunity before work commences and at his own cost any samples of materials or workmanship that may be called for by the Engineer for his approval or rejection until such samples are approved to be the acceptable standard for the work to which they apply.</p> <p>The samples shall be maintained and displayed on a designated section within the site for the duration of the project where practical and possible.</p> <p><u>PROTECTION OF EXISTING PROPERTY</u></p> <p>B The contractor shall take every precaution to avoid damage to all existing property including boundary wall, carpark, roads, cables, drains, staircases, lift etc including other services and he will be held responsible for all damages hereto arising from the execution of his contract and he shall make good all such damages when directed at his own expense.</p> <p>Any damage or disturbances caused to any element shall be reported immediately to the Engineer and the relevant Authority and shall be made good to their satisfaction at the Contractor's expense.</p> <p>C <u>PROTECTION / RELOCATION OF EXISTING SERVICES</u></p> <p>Prior to commencement of any work the Contractor is to ascertain from the relevant Authorities the exact position, depth and level of all existing electric cables, water pipes and all other services in the area and he shall make whatever provisions may be required by the authorities concerned for the support and protection and/or relocation of such services as will be necessitated.</p> <p>The contractor is also expected to generate a utility management plan to the approval of the Engineer .</p> <p>Any damage or disturbances caused to any service shall be reported immediately to the Engineer and the relevant Authority and shall be made good to their satisfaction at the Contractor's expense.</p>	
	<p>Carried to collection</p>	

ITEM	DESCRIPTION	AMOUNT
A	<p><u>MATERIALS, TOOLS, PLANT AND SCAFFOLDINGS</u></p> <p>All materials and workmanship used in the execution of the works shall be of the best quality and description. Any materials for the works condemned by the Engineer shall immediately be removed from the site at the Contractor's expense.</p> <p>The Contractor shall be responsible for the provision of all materials, scaffolding, tools, plant, transport and workmen required for the works except in so far as may be stated otherwise herein and he shall allow for the provision of the foregoing except for such items specifically and only required for the use of Nominated Sub-contractors as described herein.</p> <p>No timber used for scaffolding, formwork or similar purpose shall be used afterwards in the permanent works.</p> <p>All such plant, tools and scaffolding shall comply with all regulations whether general or local in force including Environmental, Social, Health and Safety (ESHS) policies throughout the period of the contract and shall be required as may be necessary to comply with any amendments in or additions to such regulations</p> <p>The Contractor shall keep on the site and maintain in good condition one dumpy or quickset level, metric leveling staff and one 30 metre steel tape for the use of the Architect, Surveyor and Engineer.</p> <p>The contractor may be required to provide an appropriate tower crane as required during the project life. Where a crane is provided, it should meet all regulatory and technical standards, all licences in connection with erection, usage shall be at the Contractors expense.</p> <p>The contractor may be required to provide an appropriate tower crane as required during the project life. Where a crane is provided, it should meet all regulatory and technical standards, all licences in connection with erection, usage shall be at the contractors expense.</p>	
	Carried to collection	

ITEM	DESCRIPTION	AMOUNT
<p>A</p>	<p><u>LOCAL REGULATIONS AND BY-LAWS</u></p> <p>The contractor is to comply with all local regulations and by-laws of the Local Authority including serving notices and paying of fees where applicable. These include, but not limited to: National Environmental Management Authority (NEMA), National Construction Authority (NCA), Water Resources Management Authority (WARMA)</p> <p>The Contractor will be held responsible for serving on the Chief Inspector of Factories a written notice not later than seven days after the beginning of the building operations included in this contract stating the particulars required.</p> <p><u>TRANSPORT TO AND FROM THE SITE</u></p> <p>B The Contractor shall include in his prices for the transport of materials, workmen etc to and from the site of the proposed works at such hours and by such routes as are permitted by the Authorities.</p> <p>All unit rates for local or imported goods are to include freight, insurance, handling and delivery costs to the project site together with import duties, sale tax, port charges etc and all other charges of whatever nature.</p>	
	<p>Carried to collection</p>	

ITEM	DESCRIPTION	AMOUNT
<p>A</p>	<p><u>FAIR WAGES</u></p> <p>The Contractor shall pay rates of wages and observe hours and conditions of labour not less favourable than the minimum conditions of employment applicable in the area in which the work is carried out. The relevant notice must be posted up and kept posted upon the site where it can be conveniently read by the employees concerned in languages they can understand.</p> <p>The Contractor is to comply with the regulations of Wages and Conditions of Employment Act, Building and Construction Industry Wages Council and is to be responsible for compliance of the sub-contractors employed in the execution of the contract. If required he is to notify the Engineer of the names and addresses of all such Sub-contractors. Any Contractor or Sub-contractors not complying will not be permitted to tender for other work for such a period as the Engineer may determine</p> <p>Should a claim be made to the Engineer alleging the Contractor's default in payment of fair wages to any workman employed on the contract and if proof thereof satisfactory to the Engineer, may failing payment by the Contractor, pay the claim out of any monies due or which may become due to the contractor under this contract.</p> <p>The Contractor is to furnish to the Engineer, if called upon to do so, such particulars of the rates of wages, hours and conditions of labour referred to above as the Engineer may direct</p>	
<p>B</p>	<p><u>SECURITY OF WORKS</u></p> <p>The Contractor shall be entirely responsible and shall pay security of all works, stores, materials, plant, personnel etc both his own and sub-contractors and shall also provide all necessary watching, lighting, and other precautions as necessary to ensure the security, the safety and protection of the public. He is to ensure that there is no informal business settlement near the establishment.</p>	
	<p>Carried to collection</p>	

ITEM	DESCRIPTION	AMOUNT
A	<p><u>OCUPATIONAL HEALTH AND SAFETY MEASURES</u></p> <p>The Engineer expects the Contractor to adhere to strict safety measures. In this regard the Contractor should ensure that all his workers, the Consultants and his sub-Contractors workmen are wearing Personal Protective Equipment (PPE) before commencement of any work where applicable including overalls with the company name clearly printed on the back each with clearly marked Identification Numbers stitched or imprinted on.</p> <p>The Contractor shall allow for providing all watching, lighting, barriers, signs, covering open trenches and protection of the works, including Sub-Contract works, as may be necessary for the safety of the works and for the protection of the public and his own and Sub-Contractors' employees.</p> <p>He shall also ensure provision of a certified and qualified safety, health and environmental officer, access to ambulance services at all worksites and arrangement to access a local hospital/dispensary with qualified medical staff.</p> <p>The contractor shall take cognisance and shall fullay adhrere to the regulations of the Occupational Safety and Health Act of 2007 including all the associated revisions</p> <p>The Engineer shall expect full compliance to this regulation and no excuses will be entertained for non-compliance which may lead to suspension of works until the issue is addressed satisfactorily.</p>	
B	<p><u>PUBLIC, PRIVATE ROADS AND PAVEMENTS ETC</u></p> <p>The contractor will be required to make good at his own expense any damages he may cause to the present approach and surrounding road surfaces during the period of the works</p>	
C	<p><u>POLICE REGULATIONS</u></p> <p>The contractor is to allow for complying with all Government Acts, orders or regulations in connection with employment of labour and other matters related to the execution of the works.</p> <p>The Contractor must acquit himself duly with current acts and regulations, including police regulations regarding the movement, housing, security and control of labour, labour camps, passes for transport, etc..</p> <p>Particular attention is drawn to the rules published in Legal Notice 179 dated 2nd June 1978 (Building Operations and Work of Engineering Construction)</p>	
	<p>Carried to collection</p>	

ITEM	DESCRIPTION	AMOUNT
A	<p><u>AREA TO BE OCCUPIED BY CONTRACTOR</u></p> <p>The area of the site which may be occupied by the Contractor for use as storage and for the purpose of erecting workshops etc shall be defined on the site by the Engineer</p>	
B	<p><u>PROGRESS SCHEDULE</u></p> <p>Immediately after signing the contract the Contractor is to prepare a Time Progress Chart showing the time and order in which he proposes to carry out the works within the total construction time stated in the contract. The chart will show in detail the construction time and order in which each section of the work is to be carried out and be sub-divided into trades and tasks. If the contractor proposes sectional completion of the project he must plan this in detail including access roads, and services and this shall be reflected on the chart</p> <p>Upon the letting of the Sub-Contractors work the Contractor is to incorporate times and details of each separate Sub-Contractor work which information is to be agreed by the Sub-Contractor and the chart will be so designed to accommodate this infantine.</p> <p>At the end of each week the Contractor is to mark on the chart in a different colour the actual time taken to complete the respective stages and sections of the work. The contractor shall obtain the Engineer's approval on the chart and then shall supply copies to the Engineer and Quantity Surveyor</p> <p>If at any time it should appear to the Engineer that the actual progress of the works does not conform to the approved programme progress schedule the Contractor shall produce at the request of the Engineer a revised programme showing the modifications and accelerations to the approved programme necessary to ensure completion of the works within the agreed contract period.</p> <p>The submission of and approval by the Engineer of such revisions and accelerations shall not entitle the Contractor to any extra payment or extension of time and shall not relieve the Contractor of any duties or obligations or responsibilities under the contract</p> <p>Carried to collection</p>	

ITEM	DESCRIPTION	AMOUNT
<p>A</p>	<p><u>OVERTIME</u></p> <p>The Contractor shall be responsible for any extra costs for overtime working he considers will be necessary in order to complete the works within the contract period or time for completion apart from overtime working which may be authorised by the Engineer</p> <p>If overtime is worked out in accordance with a written instruction issued by the Engineer the contractor will be reimbursed in respect of such overtime to the unproductive time payable over and above the basic hourly rates as laid down by the Regulation of wages and Conditions of employment Act, Building and Construction Industry Wages Council and excluding any bonuses, profits and overheads.</p>	
<p>B</p>	<p><u>WATER</u></p> <p>The contractor shall provide at his own risk and cost all water for use in connection with the works including the work of sub-contractors make arrangements with the local authority for the installation of a separate meter where applicable and possible for all water used by him throughout the contract and pay all costs and fees in connection therewith. He shall also provide temporary storage tanks and tubing etc as he may consider necessary and clear away at completion.</p> <p>The contractor is to provide clean drinking water at the construction site for his workers at all times.</p> <p>All water shall be fresh, clean and pure, free from earthly vegetable or organic matter, acid or alkaline substance in solution or suspension.</p>	
<p>C</p>	<p><u>TELEPHONE</u></p> <p>The contractor shall provide in the office, from the commencement to the completion of the works, a wireless or mobile phone and shall pay all charges or airtime necessary for its use</p>	
<p>D</p>	<p><u>LIGHTING AND POWER</u></p> <p>The contractor shall provide at his own risk and cost all temporary artificial lighting and power for use on the works including all sub-contractors and specialists requirements and including all temporary connections, wiring, fittings etc and clearing away on completion. The Contractor shall pay all fees and obtain all permits in connection therewith.</p>	
	<p>Carried to Collection</p>	

ITEM	DESCRIPTION	AMOUNT
<p>A</p>	<p><u>TESTING</u></p> <p>Allow for all expenses in connection with the testing of materials as specified hereunder including the supply and preparation of materials to be tested, the cost of materials and their packing and conveyance to the nearest approved Testing Laboratory, laboratory charges, etc. The following items of tests will be measured according to the number of tests actually called for by the Engineer but unsuccessful tests will not be included in the remeasurement.</p> <p>Allow for executing the following tests as detailed in the Appendices to these Bills of Quantities (PROVISIONAL)</p> <p>Water Test10.....(litres) Sand Test0.1.....(m3) Aggregate Test0.1.....(m3)</p> <p>Reinforcement test (1m of mild steel rod or high tensile steel bar of various sizes)2.....</p> <p>Concrete Test (each test comprising5 no..... cubes as described hereinafter)</p> <p>.....</p> <p>Testing of concrete or stone blocks of various strengths in accordance with Kenya Standard Specification (one test comprising5..... blocks)</p>	
<p>B</p>	<p><u>PRICING RATES</u></p> <p>The tenderer shall include for all costs in executing the whole of the works, including transport, replacing damaged items, fixing, all to comply with the said Conditions of Contract.</p> <p>Carried to collection</p>	

ITEM	DESCRIPTION	AMOUNT
A	<p><u>TEMPORARY STRUCTURES</u></p> <p>a) The Contractor shall allow for providing and clearing away on completion of the works such temporary hoarding , rubbish chutes, gates, planked walkways, guard rails etc. as may be necessary for the protection of the workers, the general public, and for the proper execution of the works.</p> <p>b) As such, temporary structures shall be constructed with the approval of the Engineer and to his full satisfaction and in such a manner as to cause minimum intrusiveness and disturbance to occupants of adjacent developments and users of the adjacent roads.</p> <p>c) All such temporary structures shall comply in all aspects with the national laws, rules, and regulations currently in force and applicable to such structures.</p> <p>d) All temporary structures shall be erected in a manner so that the unloading of materials causes minimum obstruction to the use of adjacent roads and other facilities</p> <p>e) All temporary structures shall be kept properly lighted throughout the periods of darkness and any corners or projections shall be painted white.</p> <p>g) Temporary structures shall not be used or permitted to be used for advertisement purposes except with the written consent of the Engineer</p> <p>h) All temporary structures shall be maintained at all times in good order and good condition to the satisfaction of the Engineer.</p> <p>i) All temporary structures shall be removed when so required by the Engineer or at the end of the period for which it is required.</p> <p>j) The Contractor shall indemnify and shall keep the employer idemnified against any expenses, loss, claim or suits arising out of or in connection with the temporary structures.</p>	
	Carried to collection	

ITEM	DESCRIPTION	AMOUNT
	<p><u>SITE OFFICE</u></p> <p>A The contractor shall supply, maintain, service, clean and light a fully furnished, suitable office having an approximate floor area of not less thansqm. . The office shall have a sample room suitable dimensions with clean running water and electricity connected to the approval of the Engineer.</p> <p>The Contractor shall provide offices, messrooms and all other buildings required by the Contractor for his own use and the use of by Clerk of Works and Nominated SubContractors as required by the items or attendance</p> <p>The site office shall be equipped with a table and chairs of sufficient size and number for site meetings and plan chests for drawings shall also be provided by the contractor</p> <p>The Contractor shall allow for the cost of providing light refreshment for the consultants at site meetings.</p> <p><u>TEMPORARY DISPOSAL OF RAIN WATER</u></p> <p>B The Contractor shall provide and maintain all necessary temporary gutters, downpipes, chutes, drains etc. for conveying rainwater from the buildings and storage tanks for rainwater harvesting.</p> <p>The Contractor shall allow for temporary drainage plumbing and piping for keeping the premises and site free from accumulation of water. He shall also allow for construction and maintaining any necessary storm water drainage structures as directed.</p> <p><u>CLEARING AWAY</u></p> <p>C The Contractor shall remove all temporary works, rubbish, debris and surplus materials from the site as they accumulate, on intervals as instructed by the Engineer and upon completion of the works, remove and clear away all plant, equipment, rubbish, unused materials and stains and leave in a clean and tidy state to the reasonable satisfaction of the Engineer.</p> <p>The whole of the works shall be delivered up clean, complete and in perfect condition in every respect to the satisfaction of the Engineer.</p> <p>Carried to collection</p>	

ITEM	DESCRIPTION	AMOUNT
A	<p><u>SITE ACCOMODATION & STORAGE</u></p> <p>The Contractor shall provide sheds for storage accommodation for all goods and materials liable to suffer damage from exposure to sunlight or inclement weather.</p> <p>The Contractor shall provide offices, mess rooms and all the buildings required by the Contractor for his own use and the use of Nominated Sub-Contractors as required by the items of attendance only.</p> <p>The Contractor shall provide at his own risk and cost where directed on the site weather proof lock-up sheds and make good damaged or disturbed surfaces upon completion to proof lock-up sheds and make good damaged or disturbed surfaces upon completion to the satisfaction of the Engineer</p> <p>Upon completion all temporary buildings are to be removed and cleared away</p>	
B	<p><u>SANITATION OF THE WORKS</u></p> <p>The sanitation of the works shall be provided, maintained and removed on completion by the Contractor to the satisfaction of the Engineers and local Authorities.</p> <p>The sanitary facilities shall be of generally acceptable standard regardless of the material being used to ensure ease of cleaning and maintain general well being of the users. Their location shall be agreed with the Engineers and the works shall not be commenced before the sanitary accommodation has been approved by the above mentioned authorities.</p> <p>The Contractor will be required to pay all conservancy charges and shall ensure clean daily maintenance and disinfecting of the sanitary facilities, and not less than once per week, the whole area shall be sprayed with disinfectant and insecticides and any temporary drains shall be removed and all works and surfaces disturbed made good and then the whole area disinfected and left clean and free from pollution to the satisfaction of the Engineer and local authorities.</p>	
C	<p><u>HOARDINGS</u></p> <p>The Contractor shall provide, erect and maintain throughout the course of the Contract and thereafter clear away and make good disturbed areas, temporary hoarding; approximate length of 370 metres: 3000mm high above ground consisting of: 100x50mm timber posts at 1200mm centres firmly founded and secured, 75x50mm horizontal timber rails at 900mm centres, painted GCI sheets, proper timber gates with suitable locks to Engineers approval.</p> <p>Carried to collection</p>	

ITEM	DESCRIPTION	AMOUNT
A	<p><u>DEMOLITIONS AND DOWNTAKINGS</u></p> <p>The Contractor is to allow for all temporary protection required during the works including ordinary and special dust screens, hoardings, barriers, warning signs etc. as directed by the Engineer and as necessary for the adequate protection of adjacent property and finishes, workmen employed upon the site and the public. Any damage or loss incurred due to the insufficiency of such protection must be made good by the Contractor. All protective devices are to be removed on completion of the work and any necessary making good consequent upon this is to be executed to the satisfaction of the Engineer</p> <p>All materials arising from demolitions and downtakings are deemed to be the property of the employer. No claim will be entertained on account of employer excising this right to retain the materials unless otherwise stated.</p> <p>The Contractor shall allow in his rates the cost of handling and disposal of debris arising out of the demolition works</p> <p>All downtakings shall be carefully removed, taken down, dismantled and stored on site until instructed by the Engineer to remove from the site. Such materials shall only be incorporated in the new works if required by the Engineer in which case appropriate adjustments will be made in the final account for the cost of labour, screws etc for fixing such downtakings in the new works.</p> <p>The Contractor shall be entirely responsible for any breakage or damage which may occur to materials required for re-use, during their removal, unless it is certified by the Engineer that such damage or breakage was inevitable as a result of the condition of the item concerned.</p>	
B	<p><u>ACCESS TO SITE AND TEMPORARY ROADS</u></p> <p>Means of access to the site shall be agreed with the Engineer prior to commencement of the works and the Contractor must allow for building and maintaining any temporary access roads for the transport of materials, plant and workmen as may be required for the complete execution of the works including the provision of temporary culverts, crossings, bridges or any other means of gaining access.</p> <p>Upon the completion the works the Contractor shall remove such temporary roads, temporary culverts bridges etc and make good and reinstate all works and services disturbed to the satisfaction of the Engineer.</p> <p>Carried to collection</p>	

ITEM	DESCRIPTION	AMOUNT
A	<p><u>SIGN BOARD</u></p> <p>The Contractor shall provide and erect where directed and maintain during the whole period of the building operation and remove at completion, one approved sign board of approximately 3000x3000mm and approximately 5800mm overall height to the Architect's later design giving a brief description of the works, a 3D perspective image of the project, and showing the names of the employer and the consultants, with sufficient space to append the names of the sub-contractors and suppliers when known. The lettering concerning the Architect, Quantity Surveyor and Engineer is not to be more than 50mm high.</p>	
B	<p><u>PRIME COST SUMS</u></p> <p>i) The words "Prime Cost" (or the initials "P.C") appearing in the contract documents shall mean net costs exclusive of any trade, cash or other discount whatsoever but inclusive of the costs of the packing, carriage and delivery. Such costs shall be the same due to the sub-contract or supplier after adjustments where applicable in respect of measurements of rates.</p> <p>ii) Any increase or decrease in the prime costs sums resulting from the adjustments and properly paid by the contractor shall be added or deducted from the contract sum in the final account. In substantiation the contractor will require to produce to the Quantity Surveyor all quotations, invoices and receipted accounts as shall be necessary to show the details of the sums actually paid.</p> <p>iii) Any sum added by the contractor in these Bills of Quantities in respect of profits upon any prime costs will be deducted at the final settlement of accounts and the sum will be added to the amount of which will bear the same proportion to the sum added as the net amount properly expended to the original P.C sum. The profit is a management fee for arranging and taking responsibility of the sub-contract works or arranging for and checking the supply of materials and goods from nominated suppliers.</p>	
	Carried to collection	

ITEM	DESCRIPTION	AMOUNT
A	<p><u>NOMINATED SUB-CONTRACTORS</u></p> <p>The contractor shall accept responsibility for providing the following services for nominated sub-contractors.</p> <p>i) GENERAL ATTENDANCE:</p> <p>The following services are described as "allow for general attendance" . This shall mean:</p> <p>a) Use for the purpose of the sub-contract works of any scaffolding belonging to or provided by the contractor while it remains so erected upon site, provided that no warranty or other liability on the part of the contractor or of his other sub-contractors shall be created or implied in regard to the fitness, condition or suitability of the said scaffolding</p> <p>b) Provision of water, lighting, watching and attendance for the purpose of the sub-contract works.</p> <p>c) Use of sanitary accommodation, mess rooms and welfare facilities.</p> <p>d) Provision of space for erecting of offices or stores or space for storage of plant and materials.</p> <p>ii) SPECIAL ATTENDANCE:</p> <p>The following services are described as "allow for special attendance" . This shall mean:</p> <p>a) Taking delivery and including the provision of unskilled labour necessary to attend upon the sub-contractors workmen for the purpose of unloading plants/equipment and materials of significant weight and/or size, when received upon the site and placing in position within the sub-contractor's storage space or store.</p> <p>b) Special Scaffolding, scaffolding additional to the Contractors scaffolding or Reassembling of contractor's scaffolding.</p> <p>c) Facilitating special power requirements during the course of the works.</p> <p>Carried to collection</p>	

ITEM	DESCRIPTION	AMOUNT
	<p>CLAIMS</p> <p>A It shall be a condition of this contract that upon it becoming reasonably apparent to the Contractor that he has incurred losses and / or expenses due to any of the contract conditions, or by any other reason whatsoever, he shall present such a claim or intent to claim notice to the Engineer within the contract period. No claim shall be entertained upon the expiry of the said contract period.</p> <p>PAYMENTS</p> <p>B The tenderer's attention is drawn to the fact that the payments shall be made in accordance with Clause 14 of the Conditions of Contract Agreement. In order to facilitate this, a list of the general component elements for the works is given at the summary page of these specifications and the tenderer is requested to break down his tender sum commensurate to the said elements.</p> <p>PREVENTION OF ACCIDENT, DAMAGE OR LOSS</p> <p>C The Contractor is thus instructed to take reasonable care in the execution of the works as to prevent accidents, damage or loss and disruption of activities being carried out. The Contractor shall allow in his rates any expense he deemed necessary by taking such care within the site.</p>	
	<p>Carried to collection</p>	

ITEM	DESCRIPTION	AMOUNT
<p>A</p>	<p><u>NOMINATED SUPPLIERS</u></p> <p>The contractor shall take delivery all materials or goods supplied by the Nominated suppliers and shall sign a receipt as having received them in good order and condition. He shall offload, transport to site, unload, hoist, provide safe storage and thereafter be responsible for any loss or damage or replacement of any such lost or damaged articles at his own expense and shall return case if so required.</p> <p>Provision is made herein following each appropriate P.C sums for the costs of the foregoing services against items reading "take delivery of and fix only"</p> <p><u>Fix Only:-</u></p> <p>"Fix Only" shall mean take delivery within a radius/ distance of 20 Km from the site (Unless otherwise stated), pay all demurrage charges, load and transport to site where necessary, unload, store, unpack, assemble as necessary, distribute to position, hoist and fix only.</p>	
<p>B</p>	<p><u>DIRECT CONTRACTS</u></p> <p>Notwithstanding the foregoing conditions, the Government reserves the right to place a "Direct Contract" for any goods or services required in the works which are covered by a P.C. Sum in the Bills of Quantities and to pay for the same direct. In any such instances, profit relative to the P.C. Sum in the priced Bills of Quantities will be adjusted as described for P.C. Sums is allowed.</p>	
<p>C</p>	<p><u>PROTECTION OF THE WORK</u></p> <p>The Contractor shall cover up and protect all finished work liable to damage including provision of temporary roof, gutters, drains etc until the completion of the works.</p> <p>In the event of any damages occurring to the works, materials, sewers, drains, gullies, paths or other works on site in temporary possession of the contractor for the purpose of this contract either from weather, want of proper protection, defects, or insufficiency of the works or any other causes or whatsoever during the progress of the works, the contractor shall be responsible and without extra charge, make good all damage and pay all costs which may be levied.</p>	
<p>D</p>	<p><u>BLASTING OPERATIONS</u></p> <p>Blasting will only be allowed with the express permission of the Engineer in writing. All blasting operations shall be carried out at the Contractor's sole risk and cost in accordance with any Government regulations in force for the time being, and any special regulations laid down by the Engineer governing the use and storage of explosives.</p> <p>Carried to collection</p>	

ITEM	DESCRIPTION	AMOUNT
	<p><u>PREVENTION OF NUISANCE</u></p> <p>A The works and such sections of the site necessary thereafter shall be under the entire care and control of the contractor during the whole period of the contract and shall take all possible precautions to prevent any nuisance, inconvenience or injury to the holder or occupiers of the existing or surrounding properties and to the public generally, and shall at all times keep all paths and roads affected by the works in a safe and clear state, and shall use proper precautions to ensure the safety of all wheeled traffic and pedestrians.</p> <p>The contractor shall provide appropriate screens to seal off the working area.</p> <p><u>REMOVAL OF PLANT AND RUBBISH ETC</u></p> <p>B The Contractor shall upon completion of the works remove and clear away all temporary buildings, plant, rubbish and unused materials, and shall leave the whole of the site of the works in a clean and tidy state to the satisfaction of the Engineer. He shall also remove all rubbish and dirt from the site at intervals or as directed by the Engineer.</p> <p>Particular care shall be taken in leaving windows, floors and fittings clean and the removal of all paint and cement stains therefrom.</p> <p>The contractor is expected to have established a well planned method of solid disposal of debris/garbage on and off the camp site</p> <p><u>CONTRACTOR'S SUPERINTENDENCE/SITE AGENT</u></p> <p>C The Contractor shall constantly keep on the works a literate English speaking Agent or Representative, competent and experienced in the kind of work involved who shall give his whole experience in the kind of work involved and shall give his whole time to the superintendence of the works.</p> <p>Such Agent or Representative shall receive on behalf of the Contractor all directions and instructions from the Engineer and such directions shall be deemed to have been given to the Contractor in accordance with the Conditions of Contract.</p> <p>Carried to collection</p>	

ITEM	DESCRIPTION	AMOUNT
	<p><u>TRAINING LEVY</u></p> <p>A The Contractor's attention is drawn to legal notice No. 237 of 2007 which requires payment by the Contractor for a training levy and the contractor shall allow in the preliminaries of this contract (basic rates column) for all costs arising or resulting therefrom.</p> <p>Proof of payment of this Levy should be provided at the request of the Engineer</p> <p><u>STANDARDS LEVY</u></p> <p>B The Contractor is required to make payments to the Kenya Bureau of Standards as Standard Levy inline with the current current and prevailing regulations. The Contractor shall allow in the Preliminaries of this Contract for all costs arising or resulting therefrom.</p> <p><u>VALUE ADDED TAX (V.A.T.)</u></p> <p>C The Contractor's attention is drawn to V.A.T PUBLIC NOTICE NO. 6 of 5th August, 1993 regarding the Finance Bill 1993 which expanded the V.A.T base to cover construction services amongst other items. The Contractor's attention is also drawn to all other notices issued by the government in relation to taxation. The Contractor shall familiarise himself with the said notices and allow in all his Bills of Quantities rates (Excluding P.C and Provisional Sums) for the net tax. (i.e less input tax where applicable) as required by law.</p> <p>Please note that allowing a lump sum tax either in preliminaries or in summary page shall not be acceptable.</p> <p>Any additional information and assistance concerning the application of the said notice should be directed to the office of the Commissioner of Value Added Tax</p> <p>Carried to collection</p>	

ITEM	DESCRIPTION	AMOUNT
	<u>BILL NO. 1</u>	
	<u>GENERAL PRELIMINARIES</u>	
	<u>COLLECTION</u>	
	Carried from page 1/	
	Carried from page 1/2	
	Carried from page 1/3	
	Carried from page 1/4	
	Carried from page 1/5	
	Carried from page 1/6	
	Carried from page 1/7	
	Carried from page 1/8	
	Carried from page 1/9	
	Carried from page 1/10	
	Carried from page 1/11	
	Carried from page 1/12	
	Carried from page 1/13	
	Carried from page 1/14	
	Carried from page 1/15	
	Carried from page 1/16	
	Carried from page 1/17	
	Carried from page 1/18	
	Carried from page 1/19	
	Carried from page 1/20	
	Carried from page 1/21	
	Total for General Preliminaries Carried to Grand Summary	

PROJECT PROVISIONS

ITEM	DESCRIPTION	UNIT	QTY	RATE	AMOUNT
	<u>PROJECT PROVISIONS</u>				
	Project Manager's Project Provisions. Contractor is advised to price for other preliminaries under the section of particular and General Preliminaries in the tender document				
	Project Manager's staff and Supervision				
A	Provide and maintain equipment for the Project Manager's site office for the duration of the project	Lump Sum	1		
B	Provide for supervision as follows: 1 No. Clerks of works, (Building and services) for the duration of project and 1 no. Work Inspectors, and 1 No Surveyor to be engaged on need basis.	Lump Sum	1		
C	Allow a provisional sum of Kshs. Five Million (5,000,000) for Project Management Team and other stakeholders facilitation allowances during project implementation, as and whenever it is necessary.	Lump Sum	1	5,000,000	
D	Allow for the Contractor's overheads and profits on items A,B, and C above.	%			
E	Provide with driver and maintain One (1) Type 1 vehicle, minimum 2.0 litre van or similar approved by the Project Manager, fitted with air bags, mobile telephone hand free headset and a two way radio for the exclusive use of the Project manager inclusive of the first 4,000 km per vehicle month. (The vehicle reverts to the Employer upon completion of the Project)	Lump Sum			
F	Provide for the driver, fuels, maintenance, lubricants and servicing of the vehicle for kilometrage over 1000 km per vehicle month.	Km	24,000		
G	Provide and erect publicity signboards for the whole of the project including defects liability period as will be instructed by the Project Manager and in accordance with the designs and specifications to be issued.	No.	2		
H	Provide a Prime-cost sum of Kshs Five Hundred Thousand, (500,000.00) only for carrying out environmental impact assessment before the commencement of works and and undertaking environmental mitigation measures as the work progresses.	No.	1	500,000	
J	Provide a Prime-cost sum of Kshs five Hundred Thousand, (500,000.00) only for carrying out Geotechnical survey before the commencement of works and preparation of the reports	Sum	Item	500,000	
K	Allow a provisional sum of Kshs. Two Hundred and Fifty Thousand (250,000.00) for stationery, documentation, model making, review and preparation of as built drawings Manager.	Lump Sum	1	250,000	
	Contractor's profits and overheads				
L	Allow for the Contractor's overheads and profits on items E, F G, H, J and K above.	%			
	PROJECT PROVISIONS CARRIED TO GRAND SUMMARY				-

SPECIFICATIONS

Reference is made to the General Specifications for Building Works (1976) by the Ministry of Works, Housing and Physical Planning.

A copy is available for perusing at the request of the procuring entity.

Contractors are required to adhere to the latest industry standards as outlined in the most recent version of KS (Kenyan Standards) / BS (British Standards) EN International standards. Failure to comply may result in project delays or financial penalties. It is the responsibility of the Contractor to stay informed about and apply the current industry standards throughout the construction process. Any disputes arising from non-compliance with updated standards will be subject to resolution through dispute resolution mechanism outlined in the contract.

PREAMBLES

EXCAVATION AND EARTHWORK

Nature of Excavation

- A The Contractor must ascertain for himself the nature of the materials to be excavated and price the work accordingly as no allowance will be made beyond the Contract Sum for any alleged ignorance in this respect.

Site Clearance

- B. The Contractor shall clear the construction areas within the site of all bushes, roots, brush, boulders, natural obstructions, rubbish and any other natural or artificial obstructions which would interfere with construction of buildings, roads, paths and drains.
- C. Clear away all anti/termite hills and nests over the area of the site, excavate for, locate and destroy queens.
- D. Treat the cavity formed by the removal of the nest as described hereinafter under "Soil Sterilization" and backfill with approved material well rammed and consolidated in layers not exceeding 300 mm thick.
- E. All areas of the site must be thoroughly proofed against rodents and special care must be taken to ensure that no unconsolidated areas are left near banks and ditches.

Commencing Levels

- F. Unless specifically stated otherwise the commencing levels for excavation shall be deemed to be existing ground level or underside of reduced level excavation.
- G. All measurements are based upon reduced level excavation being executed first and no adjustment will be made should a differing sequence of operations be adopted, unless specifically ordered by the Architect in writing.

Excavations

- H. Excavations shall be to the widths and depths indicated the drawings or to such lesser or greater depths as the Architect may deem necessary and so instruct the Contractor in order to obtain satisfactory foundations.
- J. Any difference in the quantity of works actually executed under such instructions and that provided in the Bills of Quantities shall be measured and valued by the Quantity Surveyor as a variation under the relevant Conditions of Contract.
- A. If, however, the Contractor excavates to any greater depth or widths than are shown on the drawings or directed by the Architect, then the Contractor shall at his own expense fill in such extra depths and widths with concrete similar to that described for foundations to the satisfaction of the Architect.

Bottoms to Excavation

- B. The Contractor shall report to the Architect as and when a secure bottom to the excavations has been obtained and the same is ready to receive concrete. Any excess depth unnecessarily excavated below the formation level shall be backfilled with and compacted as directed by the Architect and no payment shall be made for excess excavation or for the fillings & compaction
- C. Any concrete or other work put in before excavations have been inspected and approved shall, if so directed, be removed and new work substituted after excavations have been approved all at the Contractor's expense.
- D. If so directed, the Contractor shall water and well ram the bottoms of excavations to the satisfaction of the architect.

Measurement of Excavation Work

- E. Excavation work is measured net as before digging and the Contractor must allow for increase in bulk after digging.

Trenches for pipes, cables kerbs, etc., other than drain pipes

- F. Prices for excavation of trenches for pipes, cables, kerbs, etc., shall include for grading and ramming bottoms to the levels required, all necessary planking and strutting, carefully returning, filling and ramming selected excavated materials and for carting away any surplus materials.

Rock

- G. Any rock or other hard materials encountered in excavating to the required depth which, in the opinion of the Architect, can only be removed by wedges or compressor plant shall be paid for as an extra and the price shall include for trimming and levelling. No blasting will be allowed. Hard compacted murrum which can be removed by pick will not be classed as rock notwithstanding that the Contractor may decide to remove it by wedges or compressor plant.
- H. The Contractor must give notification to the Architect or his representative when such material is encountered and its extent must be agreed with Architect or Quantity Surveyor or their authorised representative before the work is carried out. No allowance will be made for rock excavation unless the foregoing procedure has been followed.

Rates for Excavation

- J. The rates for excavation shall include for excavating by hand or machine in all types of materials except rock, as previously specified.
- A. Excavations for plain concrete foundations have been measured to the **net sizes** required by concrete dimensions.

- B. An allowance for working space and formwork has been measured to reinforced concrete foundation, but if the Architect's approval is given to pouring concrete against the face of the excavations these items will be measured and adjusted in the Final Account.
- C. The rates for excavation must include for such excavating in all types of ground encountered including sand, murrum, hard murrum, tree roots and loose boulders.

Levelling

- D. No item is measured for levelling and consolidating ground and rates for excavations must include for levelling and preparing the ground for concrete or other works including ramming or rolling.

Disposal of Water

- E. The Contractor shall keep the excavations free from standing water and silt (or excavated materials softened by water) and he shall include for the cost of pumping, construction of temporary drains, soakaway pits, etc., as deemed necessary to achieve this. An item has been included for this in the Bills of Quantities in each relevant section. The cost of pumping to dispose of any spring or running water has been covered by Provisional Sum. If spring or running water is encountered, the cost of any pumping ordered by the Architect will be paid for in accordance with the Dayworks Schedule.

Planking and Strutting

- F. Sides of all excavations must be supported in order to prevent falls from or collapse of the earth face. The term "planking and strutting" is deemed to include any method or methods which the Contractor elects to adopt, uphold, protect and maintain the sides of excavations. The Contractor will be responsible for any consequences of his failure in this respect including clearing away fallen materials and any extra concrete or other works including formwork ordered by the Architect due to such failure. An item has been included in these Bills of Quantities in each relevant section.

Return, Fill in and Ram

- H. Material returned around foundations externally shall be selected hard, dry excavated materials arising from the excavations free from vegetable soil, roots and rubbish carefully filled in, spread, watered and compacted in layers not exceeding 200 mm thick. Backfilling internally shall be hardcore, or selected hard dry granular materials as above to approval.
- J. No excavations or foundation work shall be filled in or covered up until all measurements necessary for the adjustment of variations have been made. Walling shall not be built upon the foundations until four days after deposition of concrete.

Cart Away

- A. All surplus excavated material, where so directed, and all rubbish is to be removed from the site and the Contractor is to find his own dump and pay all charges.

Approval Before Filling

- B. No fill materials shall be placed before approval has been given by the Architect for filling to begin.

Measurement of Filling Generally

- C. Filling is measured net as after consolidation.

Earth Filling

- D. Levels specified to be made up with surplus soil, etc., are to be filled in with selected soil free from vegetable growth to the approval of the Architect and is to be laid in layers not exceeding 200 mm thick, each layer to be levelled, well rammed and consolidated and watered if necessary.

Hardcore Filling

- E. Hardcore shall consist of clean hard broken stone or rubble graded to pass in all directions a 100 mm ring with sufficient sand added to fill the interstices. The hardcore shall be well packed, rammed and where possible, rolled with a heavy roller. Where rolling is impossible compaction shall be by hand or by mechanical tampers. Before any concrete is laid on hardcore, the hardcore shall be levelled and blinded with sand, rolled and well watered through a sprinkler rose.

Borrow Pits

- F. No borrow pits will be allowed to be opened on the site

Soil Sterilization

- G. Anti-termite treatment is to be carried out using one of the chemicals below and the Contractor will be required, upon completion of the soil sterilization, to furnish a written guarantee certifying the following:-

- (a) That the chemicals applied comply with the requirements specified herein for chemical concentration and rates of application.
- (b) That the treatment will remain effective against termite infestation for a period of five years.
- (c) Application shall not be done whilst its raining or to surface of filling which are wet, and strictly in accordance to manufacturer's instructions

Soil Sterilization

- A. The chemicals used shall be one of the following:-

- 5 Termicide A; 1 part to 45 parts water
- 7 Pentachlorophenol; 5% in oil solution
- 8 Trichlorobenzene; 1 part to 3 parts oil

- B. Some of the chemicals listed above are toxic to animals and plant life and must, therefore, be applied only with caution by an experienced person. Where individual water supply systems are proposed, precautions must be taken to prevent infiltrating and endangering the water supply. Treatment shall not be made when soils or fill is excessively wet or immediately after heavy rains.
- C. Precautions must also be taken to prevent disturbance of the treatment by animals or human contact with the treated soil. The treated areas are to be covered as quickly as possible after treatment.
- D. The rate of applications is to be 7 litres per square meter and the areas measured include those under floor and around wall and column foundations.

CONCRETE WORK

Code of Practice for Reinforced Concrete Work

- A. All workmanship, materials and tests in connection with reinforced concrete work are to be conformity with B.S. Code of Practice B S 8110 : 1985 - The Structural Use of Concrete.

Generally

- B. A competent person shall be employed whose first duty it will be to supervise all stages in the preparation and placing of concrete. All cubes shall be made and site tests carried out under his direct supervision.
- C. All materials which have been damaged, contaminated or have deteriorated. or which do not comply in any way with the requirements of the specification, shall be rejected and shall be immediately removed from the site.
- D. No materials shall be stored or stacked on suspended floors without the Engineer's prior approval.

Samples

- E. Samples of all materials are to be submitted for approval of the Engineer at least one week before it is desired to commence deliveries. All condemned materials are to be removed from the site within 24 hours.

Cement

- F. Cement used shall be ordinary Portland cement and shall be obtained only from manufacturers approved by the Engineer, and shall comply in every respect with B.S. 197-1. The Contractor at his own expense may use rapid hardening Portland Cement (to B.S. 197-1) in order to speed up progress of the Works. If rapid hardening Portland Cement is used, the prior approval of the Engineer shall be obtained in writing.

- G. Each consignment of cement shall be accompanied by the manufacturer's certificate showing that a representative sample of the consignment has been tested and complies with the appropriate specification. From time to time as requested by the Engineer, copies of the cement manufacturer's test certificates shall be delivered to the Engineer or his representative on the site promptly, but such documents shall not preclude the Engineer from rejecting any cement which does not in every way comply with the specification.

Cement Storage

- H. The cement must be delivered in the manufacturer's sealed and branded bags and stored separately in dry, water-tight stores with their floors raised above ground level and shall be at all times carefully protected from moisture.
- I. The cement shall be stored in such a way that each consignment may be identified and used in the order of its delivery. Cement may be delivered in bulk containers provided additional suitable arrangements are made for bulk storage on site to the approval of the Engineer.

Inferior Cement

- A. Any cement which has failed to pass the tests or has been damaged by water or contaminated in any way on site shall immediately be put into bags and removed from the site.

Aggregate

- B. Aggregates shall be granite or other equal and approved obtained from an approved source and shall comply with B.S. 1260. They must be chemically inert, strong, hard, durable, free from adhering coating, salts, organic or other impurities and shall be washed or screened as directed.

Fine Aggregate and Sand

- C. Fine aggregate and sand shall be clean, sharp, coarse, hard siliceous materials and equal at all times to the samples which shall be deposited with and approved by the Architect or Engineer. It shall comply with the requirements of B.S. 1260, Table 2, Zones 1,2 or 3. The caustic soda tests for organic impurities shall show a colour not deeper than that of the standard solution. The settling test for natural sand shall be made and after being allowed to settle for three hours the layer of silt deposit on the coarse materials shall not exceed 10% for crushed stone and 3% for natural sand or crushed gravel.
- D. The Contractor shall supply all necessary equipment for testing of fine aggregate and sand for use of the Clerk of Works.

Coarse Aggregates

- E. Coarse aggregates shall be granite from approved quarries, clean, free from earth and extraneous matter, and shall conform to B.S. 1260. The amount of fine particles occurring in a free state or as loose adherent shall not exceed 1% when determined by the laboratory sedimentation test.

- F. After twenty-four hours in water, a previously dried sample shall not gain more than 1.0% in weight for crushed stone or 3% for natural sand or crushed gravel
- G. The four nominal aggregate sizes shall be 40 mm (1.5"): 20 mm (.75"): 10 mm (3/8"): 6 mm (1/4") : and the grading when analyzed as described in B.S. 812 shall be within the limits given in B.S. 1260.

Aggregate Storage

- A. Each grade of aggregate shall be stored in the works in separate heaps so that there shall be no possibility of any inter-mixing. Any materials which have become inter-mixed shall be removed from the site forthwith by the Contractor.
- B. The materials shall be stored on a timber or concrete floor and the piles shall be as large as possible, flat topped and drained.

Water

- C. All water used on the Works shall be clean, free from earthy vegetable and organic matter and from acidic and alkaline substances in suspension or solution. It shall preferably be obtained from the water mains of the Ministry of Water and Energy Department or Water Authority and shall be stored in proper water storage tanks to the approval of the Architect or Engineer. Any approved water shall be tested in accordance with B.S. EN 1008.

Admixtures

- D. Admixtures of any kind for accelerating the setting of cement, plasticiser, hardeners, water proof etc., shall be used only if approved or specified by the Architect or Engineer.

Proportion of Concrete Mix

- E. The quantity of cement shall be measured by weight and each batch of concrete is to use one or more whole bags. The quantity of fine aggregate and coarse aggregate shall be measured separately by weight in an approved weight batching plant. Volume mixing will not be permitted. The weight of damp aggregates must be adjusted to take into account the weight of water in the aggregates, and must be adjusted to take into account the weight of water in the aggregates, and this in turn will affect the amount of water to be added into the mix.
- F. Throughout the carrying out of the Contract "Work Tests" are to be made from concrete drawn from newly laid concrete or concrete about to be placed in position, such cubes being made when directed by the Clerk of Works and in his presence. Such cubes shall be made in 150 mm or six inch cube steel or cast from mould and shall be marked and cured strictly in accordance with Appendices of the Code of Practice, and shall be forwarded carriage paid in time for testing at the required age to a testing laboratory to be nominated by the Architect or Engineer.

- G. Six cubes shall be made on each occasion, and cured in compliance with B.S. 1881 Part 3, 1983 concrete for each cube being from a difference batch. Three cubes shall be forwarded in time for testing at the age of seven days from casting and three cubes in time to testing in twenty-eight days. Each cube shall be marked with the date of casting and a distinctive reference number in accordance with a system agreed by the Engineer. A record shall be kept of the position from which the concrete for each set of cube was drawn, or to which it was about to be placed.

Concrete Work Cont'd

- A. At least three sets of six cubes shall be cast during each week concrete is being cast including sets of cubes for each quality of concrete used during the period.
- B. Concrete is required to have the properties and give the strength in Newtons per square millimetre as set out in the table below which is to be considered as the minimum standard that will be accepted in the finished Works.
- C. The workability of the fresh concrete should be such that concrete is suitable for handling, placing and compaction so that it surrounds the reinforcement, tendons and ducts and completely fills the formwork.

Grade	Quality	Maximum size of coarse aggregate	Maximum Water Cement Ratio by weight of Aggregate	Minimum Crushing Strength of Works Test Cubes	
				7 days	28 days
30	1:1:2	20	0.45	30	36
25	1:1.5:3	20	0.55	21	26
25	1:1.5:3	10	0.55	21	26
20	1:2:4	20	0.60	14	21
20	1:2:4	10	0.60	14	21
15	1:3:6	10	0.60	-	12
10	1:3:6	10	0.60	8	10
7	1:4:8	40	0.60	-	7
-	1:10	All in Agregate		-	-

- D. If the strengths required in the table are not attained and maintained throughout the carrying out of the Contract, the Contractor will be required to increase the proportion of cement or substitute better aggregate at his own cost so as to give concrete which does comply with the requirements of this Clause. The Contractor may be required to remove and replace at his own cost any concrete which fails to attain the required strength as ascertained by the Works Cube Tests.

Unsatisfactory Concrete Work

- E. Should in the opinion of the Engineer any of the results of the specified tests of concrete or materials be unsatisfactory, the Engineer may order the work to be stopped pending his further instructions. Executed work for which test cubes are unsatisfactory shall be liable to rejection and, if so directed by the Engineer, the work represented by the tests shall be cut out and re-executed at the Contractor's expense.

- A. In the case of seven day Works Cube Tests proving unsatisfactory, the work may be stopped, but shall not be liable to rejection until the result of the twenty-eight day test is known.
- B. In the event of the results of the twenty-eight day Works Cube Tests proving unsatisfactory, the work represented shall be immediately liable to rejection. The Contractor may, however, be given the option of cutting three specimens from the completed work subject to the direction of the Engineer, and preparing therefrom test cubes or cores Tests in accordance with the requirements of Part 4 of B.S. 1881 Part 3, 1983. which shall be sent to the Testing Laboratory for testing as for Works Cube
- C. Should the average strength of these specimens attain the specified minimum twenty-eight day strength, the work will, subject to the Engineer's discretion be accepted. Alternatively, the Engineer may instruct the Contractor to make a loading test as described hereinafter. The cost of all cutting, preparation of specimens, testing and making good the portions of the structure affected, shall be borne by the Contractor. The cost of all delays on site due to concrete not attaining the desired strength, or caused by investigation of defects, cutting away and making good, shall be entirely the Contractor's responsibility.

Structural Test

- D. If, in the Engineer's opinion, there is a doubt as to the strength of a structure, solely or in part, for the reason that the site-made concrete cubes fail to attain the specified fail, the Contractor shall be reimbursed for the cost of the test. If the result of the test is not satisfactory, the Contractor shall bear the cost of the test and the cost of correcting any defects in accordance with the instructions of the Engineer. strength, or because of one or more circumstances attributable to alleged negligence on the part of the Contractor to make a loading test on the Works or any part thereof. The nature of the test and the loading shall be in accordance with Clause 605 of C.P. 114. If the result of the test is satisfactory, except where the test has been made because test cubes

Formwork

- E. The formwork shall be so constructed as to remain sufficiently rigid during the placing compaction of the concrete and shall be sufficiently tight to prevent loss of liquid from the concrete. Vertical strutting shall be carried down to such construction as is sufficiently strong to afford the required support without injury. All rubbish, chippings, shavings and sawdust shall be removed from the interior of the forms before the concrete is placed, and suitable washout holes shall be provided to facilitate this, and the formwork in contact with the concrete shall be clean and thoroughly wetted and treated with the approved mould oil. Care shall be taken that such oil is kept out of contact with the reinforcement and shall be used sparingly as possible. In no circumstances shall forms be struck until the concrete reaches a cube strength of at least twice the stress to which the concrete may be subjected at the time of striking, and in any case the minimum permissible times shall be as follows:-

Vertical sides of wall and columns	2 days
Sides of beams and lintels	2 days

Soffits of slabs (Subject to retention of props until 21 days	14 days
Soffits of beams and lintels (Subject to retention of props until 21 days)	14 days

- A. No formwork is to be removed if, in the opinion of the Engineer, the concrete has not hardened sufficiently. Approval of the Engineer shall not relieve the Contactor of his liability to make good any concrete which may be damaged by premature removal or collapse of forms. Notwithstanding any other clauses in this specification the responsibility for the safe removal of the formwork rests with the Contactor.
- B. All formwork shall be removed without such shock or vibration as would damage the reinforced concrete.
- C. Forms shall be true to lines and levels and braced and strutted to prevent deformation.
- D. Before placing of the concrete, bolts and fixings shall be in position and cores and other devices used for forming openings, holes pockets, recesses, ducts or other cavities shall be fixed to the shuttering.
- E. Concrete shall not be poured in horizontal layers to a depth exceeding 1500 mm in formwork, except where prior approval of the Engineer has been obtained.
- F. Formwork is measured to the actual net surface of the concrete to be supported and the Contractor shall allow in his prices for any waste, fixing at the various levels, straight cuttings, splayed edges, notchings, fillets to form chamfered arises, extra materials, joints, overleaves for angles, extra labour for narrow widths and small quantities, props, stays, struts, hangers, brackets, edges, wiring, bolts, and everything necessary to keep all quite firm and rigid, and any other labour and materials necessary to fix, ease, adjust and remove the formwork as described.

Normal Finish to Faces of Structural Concrete

- G. After removal of shuttering, unless instructed to the contrary, the face of exposed concrete is to be rubbed down immediately to remove fins or other irregularities. In the event of parts of the concrete being honeycombed, such portions are to be cut to a depth and shape required by the Engineer and made up with fine concrete of equal quality in such a manner as shall be directed. The face of concrete for which shuttering is not provided, other than slab, is to be smoothed with a wooden float to give a finish equal to that of the rubbed-down surface where shuttering is provided. The top face of a slab which is to not intended to cover with other materials is to be levelled and floated before setting to a smooth finish at the level or falls shown on the drawings or elsewhere. The floating must be carried out in such a way as will prevent an excess or mortar being brought to the surface of the concrete. The top face of a slab intended to be surfaced with mortar, granolithic, or similar materials is to be brushed with a stiff broom while still green to remove any laitence © and to provide a roughened surface.

Fairfaced Concrete

- A. Where so described or measured, faced of concrete shall be finished fair by means of formwork lined with approved waterproof plywood so as to produce a perfectly true surface and shall have all imperfections in the concrete face cut out, made good in cement mortar and rubbed down with carborundum stone and finally bag rubbed with cement slurry to finish to a high standard without trace of shuttering marks, joints or other disfigurements.

Wrought Boarded Face Formwork to give a Board Mark Finish

- B. Where so described or measured, faces of concrete shall be finished fair by means of 100 mm or 150 mm (nominal) width tongued and grooved boarding of 25 mm (minimum) thickness. The edges of all boards shall be nominal 2 mm chamfer to form controlled fins.
- C. Such formwork to column faces shall be of continuous length boards between construction joints.
- D. End joints will be permitted to beams faces, etc., and shall be tongued, staggered and well distributed.
- E. All imperfections shall be cut out and made good in concrete of equal quality.
- F. The resulting concrete shall show grain and individual board marks, be free from honeycombing and excessive air holes, of uniform colour and to the entire satisfaction of the Engineer.

Wall Ties

- G. Where blockwalls abut columns or solid concrete walls two 6 mm diameter steel reinforcing bar ties are to be cast into the concrete at vertical intervals of 400 mm. Ties to be 300 mm long and project 150 mm into blockwork.

Holes, Pipes Etc.

- H. The Contractor shall be responsible for the co-ordination with sub-contractors for incorporating any electrical conduits pipes, fixing blocks, chases, holes, etc., in the concrete members as required. The Contractor shall submit full details of these items to the Engineer for approval before the work is put in hand. Concrete fixing blocks may be embedded in the concrete provided that the strength or effective cover of any part of the structure is not adversely affected nor the finished work damaged by any movement of the blocks. All fixing blocks, chases, holes etc., to be left in concrete shall be accurately set out and cast with the concrete. No openings, chases, holes or other voids shall be cut or formed in concrete without the approval of the Engineer.

Blinding Concrete

- A. No casting of any concrete on the ground shall take place until the ground has been passed as satisfactory by the Engineer. All ground to carry reinforced concrete shall be covered with a 50 mm minimum blinding layer of concrete 1:4:8. The cover for concrete under reinforcement shall be entirely above the blinding layer.

Mixing

- B. Concrete is to be mixed in a batch mixer of approved type having a drum rotating about a horizontal or inclined axis. The speed of the drum is to be not more than twenty and not less than fourteen revolutions per minute. Each mixer is to be fitted with a water measuring device capable of accurate measurement to one gallon for one cubic yard mixers and pro rate for smaller sizes and so arranged that the accuracy is not affected by variations in the pressure of the water supply line.
- C. The fine and coarse aggregate and the cement are to be mixed for at least four turns of the drum, after which the required amount of water is to be added gradually while the drum is in motion and the concrete then mixed for at least one and a half minutes and until a mix of uniform colour and consistency is attained.
- D. The volume of concrete mixed in any one batch is not to exceed the rated capacity of the mixer.
- E. The whole of the mixed batch is to be removed before materials for a fresh batch enter the drum.
- F. On cessation of work, including all stoppages exceeding twenty minutes, the mixers and all handling plant are to be washed out with clean water.
- G. Concrete mixed as above is not to be modified by the addition of water or otherwise in order to facilitate handling, or for any other purpose.
- H. At least one slump test shall be made each day concreting is in progress under the supervision of the Clerk of Works. The slump shall not exceed 75 mm but at 25 mm slump may be allowed by the Engineer in certain structural members.

Transporting

- J. Concrete is to be handled from the place of mixing to the place of final deposit as rapidly as practicable by the methods which will prevent segregation or loss of ingredients and maintain the required workability. It should be deposited as nearly as practicable in its final position to avoid rehandling.
- K. Concrete shall be placed into the forms from as small a height as possible and shall in no case be dropped from a height of more than 1500 mm except with the approval of the Engineer.
- A. When chuting is used, the inclination of the chute must be such as to allow the concrete to flow without the use of excessive water and without segregation or loss of the ingredients. Details of any proposed chuting plant must be approved by the Engineer before the plant is delivered to the site.
- B. If the Contractor wishes to distribute concrete by means of pumps, full details of the system must be made available to the Engineer for approval.

Placing and Consolidation

- C. The concrete shall be placed before setting has commenced and in any case within thirty minutes from the time the water is added, and must not be subsequently disturbed. Concrete shall be thoroughly compacted during the operation of placing, and thoroughly worked around the reinforcement, around embedded fixtures, and into corners of the formwork. Mechanical vibration with an approved type insertion vibrator shall be used.
- D. The use of mechanical vibration will not relieve the Contractor of his responsibility for making good work which may be damaged by excessive or ill-applied vibration.
- E. All methods of placing and consolidation of the concrete are to be such as not to cause any disturbance or movement to the formwork or reinforcement. After being placed in position, the concrete is to be left absolutely undisturbed by any movements or thrusts while setting.
- F. An accurate record is to be kept by the Contractor showing dates and times when various portions of the work were concreted. The concreting foreman must not vary the approved mix or water content without the permission of the representative of the Engineer. It may occasionally be found that in constructed structural members or where the proportion of reinforcement to concrete is high, the workability of the concrete must be increased locally in order to effect full compaction. Such increase in workability shall be achieved by an increase in the cement content of not more than 10% of the concrete by weight in any single batch and must be made only with the approval of the representative of the Engineer.
- G. The workability of the concrete must never be altered by the use of additional water or sand alone.

Construction Joint

- H. The form and location of all construction joints shall be approved by the Engineer before commencement of work.
- A. The centering to form the stop shall be fitted with splay fillets on the concrete face and will be firmly fixed and scribed around the reinforcing steel. If any concrete shall flow past the stop, it shall be hacked off as soon as the concrete has set. Before any new concrete is placed up against the stopped face, the concrete previously placed shall be hacked and scoured with a wire brush to remove the scum. The joint shall then be soaked with water and covered with a sand cement mortar of proportions in the same ratio in the concrete used. In all cases of application of mortar the punning must be adequate to incorporate the mortar in the body of the concrete. In no circumstances shall the concrete be allowed to finish at a break running down a rough slope. Such cases, if found, will be treated as contrary to the specification and the Contractor will be required to cut out the member and re-cast. In the case of horizontal joints, any excess water and laitance shall be removed from the surface after the concrete is deposited and before it has set.
- B. Before casting slabs the haunchings or seatings for the slab shall be thoroughly hacked, scoured and washed and covered with at least 5 mm of mortar immediately before the slab is cast.

- C Slabs to be cast using alternate bay construction, maximum size of single panel 40 square meters.

Column Plinths

- D Column kicker plinths 75 mm high not cast monolithically with the beam or slab will be allowed only at the discretion of the Engineer and special precautions must be taken if permission is granted, especially in regard to the quality of the mix used and the curing of concrete.

Curing

- E The curing of the concrete must receive particularly careful attention. The concrete shall be covered with a layer of a sacking, canvas, hessian or suitable absorbent materials, and concrete, formwork and covering kept constantly wet for the first seven days after casting. Foundation concrete must be protected from falling earth and kept free from deleterious substances.

Dimensions of Finished Concrete

- F Except where specially noted, dimensions, levels, sizes, positions, and covers are to be exactly as dimensioned or specified with the following tolerances for concrete cast in situ.
 - (a) For sizes of beams or columns, slab or wall thicknesses, not less than specified, nor more than 5 mm above. Dimensions between column faces not to have a greater tolerance than 10 mm.
 - (b) For layout positions or dimensions horizontal or vertical 5 mm plus or minus.
 - (c) Levels of floor, ceilings, beams, lintels, etc., (top and bottom), 5 mm plus or minus and no surface intended to be horizontal must slope more than 2 mm in 1 meter.
 - (d) Errors in plumbing 5 mm plus or minus, and no line or surface intended to be vertical must slope more than 2 mm in 1 meter.
 - (e) For cover of concrete around reinforcement 3 mm plus or minus.

Permissible tolerance shall not be cumulative.

Steel Reinforcement

- A. Mild steel rod reinforcement shall comply with B.S. 4449.
- B. High tensile steel rod reinforcement shall be hot rolled deformed steel complying with B.S. 4661 grade 460.
- C. Welded steel fabric reinforcement shall comply with B.S. 4483.
- D. The steel shall be stored so that it is kept clean and reasonably free from rust.
- E. All metal for reinforcement is to be free from loose mill scale, loose rust, oil and grease, or other harmful matter immediately before placing of the concrete.

- F. All reinforcement is to be placed and maintained in the positions shown on the drawings. Some definite method of ensuring the amount of cover required by the designer must be agreed between the Contractor and the Engineer.
- G. Reinforcement must be bent or straightened in a manner that will not injure the materials, and in accordance with B.S. 4466.
- H. All bars are to be bent cold.
- J. Starter bars are to be positioned accurately.
- K. All crossings of bars are to be securely wired.
- L. Bars at the top of slabs are to have substantial support.
- M. The prices of all rod reinforcement are to include for cutting to lengths and for all bending, hooked ends, etc., and for placing in position with distance pieces where necessary to ensure the rigidity of the bars and for tying together with approved wire in order to prevent displacement during concreting.
- N. The placing of all reinforcement shall be checked by the Engineer and in no circumstances is concrete to be deposited around any steel that has not been passed. At least forty eight (48) hours notice shall be given to the Engineer that reinforcement will be ready for inspection.
- O. Where bending schedules are provided, the measured weight of reinforcement for purposes of payment will be taken from the bending schedules and the Contractor must make due allowance in his rates for rolling margins and all the foregoing items and labour including cutting to waste from random lengths.

Cover to Reinforcement

- A. The thickness of the concrete cover to reinforcement shall conform in all respects to the B.S. Code of Practice B. S. 8110 : 1995 unless specifically shown on the drawings. Some approved method of ensuring the correct amount of cover shall be used.

Spacing Blocks and Chairs etc.

- B. Properly formed spacing blocks of concrete with wire ties or other approved means shall be securely wired or attached to the reinforcing bars to ensure the maintenance of the proper cover of concrete.

- C. These shall be dense concrete left with a wire brushed surface or dipped in grout before fixing. These blocks are particularly important where the surface of the concrete is exposed to the weather or dampness. The Contractor must ensure that the bars are securely fixed so as to maintain their indicated positions during the progress or pouring, tamping or vibration of concrete. Four chairs per drop are to be provided around columns to hold steel in positions and chairs are to be made up of 12 mm diameter mild steel bars. The cost of all such fixing steel must be allowed for the Contractor in his rates for reinforcement generally.

Precast Concrete

- D. Concrete shall all be cast in properly made strong mould to form shapes required. For work described as "finished fair" the mould shall be lined with sheet iron or other approved material.
- E. The coarse aggregate for precast concrete shall be 10 mm gauge where 1:1.5:3 mix concrete is specified.
- F. The concrete shall be of the mixes described and shall be thoroughly tamped in the mould and shall not be removed from them until seven days after placing the concrete, but the sides may be removed after three days providing the mould are such that the sides are easily removable without damaging the concrete.
- G. The precast work shall be cast under sheds and shall remain under same for seven days in the mould and a further seven days after removal from the moulds. During the whole of this period the concrete shall be shield by sacking or other approved materials and kept wet. It shall then be removed from the sheds and stacked in the open for at least seven days to season.
- H. All precast work shall be in lengths convenient for handling, unless otherwise described.
- J. Prices for precast concrete shall include for all moulds, hoisting and fixing to the levels required, bedding and pointing in cement mortar (1:3) and for finishing exposed faces fair and smooth where so described.

WALLING

Setting out Walling

- A. The Contractor shall provide proper setting out rods and set out all work on same for courses, openings, heights, etc., and shall build the walls and piers etc., to the widths, depths and heights indicated on the drawings and as directed and approved by the Architect.

Cement

- B. Cement shall be described in Concrete Work.

Fine Aggregate

- C. Fine aggregate for concrete blocks shall be as described for fine aggregate in Concrete Work.

Coarse Aggregate

- D. Coarse Aggregate for concrete blocks shall be good, hard, clean aggregates from approved quarries. It shall be free from all decomposed materials and shall be graded up to 10 mm all as described for coarse aggregate in Concrete Work.

Concrete Block

- E. Concrete blocks for walling shall be provided by the Contractor complying with B.S. 2028 Type A, and made in approved block making machines or a composition as follows:-

Portland Cement; 1 Cubic Meter

Fine Aggregate (graded up to 5 mm); 3 Cubic Meters

Coarse Aggregate (graded up to 10 mm); 6 Cubic Meters

- F. Blocks shall be solid or hollow two-hole type as specified and are to be made under sheds erected by the Contractor to the directions and approval of the Architect. In hollow blocks of the volume of the cavities shall be not less than 45% and not more than 50% of the gross
- G. The compressive strength Type A blocks shall be not less than:-

Average of 13 hollow blocks; 5.75 N/mm² gross area

Lowest individual hollow block; 4.0 N/mm² gross area

- A. The concrete is to be put into the machine's moulds in thin layers and all properly tamped therein. On removal from the machines the blocks are to be carefully deposited on wet the whole time, after which they shall be put out in the open on racks and protected with the approved matting, sacking or straw and kept wet for a further five days, then kept in the same position and under the same mat cover, but without wetting, for a further two days and then left in the open without matting or wetting for a further seven wet the whole time, after which they shall be put out in the open on racks and protected with the approved matting, sacking or straw and kept wet for a further five days, then kept in the same position and under the same mat cover, but without wetting, for a further two days and then left in the open without matting or wetting for a further seven days to season. All blocks must be left with good sharp edges. The blocks for use in the Works shall be 190 mm high and may vary in length from 300 mm to 400 mm and no variation above or below these lengths will be allowed except where required to form proper bonding at corners, round openings, sills, lintels, beams, etc., and the like positions and the Contractor must make or cut blocks to all the varying sizes required for these purposes and include this in his price. days to season. All blocks must be left with good sharp edges. The blocks for use in the Works shall be 190 mm high and may vary in length from 300 mm to 400 mm and no variation above or below these lengths will be allowed except where required to form proper bonding at corners, round openings, sills, lintels, beams, etc., and the like positions and the Contractor must make or cut blocks to all the varying sizes required for these purposes and include this in his price. racks under sheds erected by the Contractor to the direction and approval of the Architect and there left for three days and kept thoroughly

Bonding Walling

- B. The blocks shall be properly bonded together in such manner that no vertical joint in any one course shall be within 100 mm of a similar joint in the courses immediately above or below. Sufficient through bonders shall be provided as directed by the Architect. Alternate courses of walling at all angles and intersections shall be carried through the full thickness of the adjoining walls. All walling shall be built up entirely solid in blocks without void, allowance being made for joints 10 mm thick only. All perpend, reveals and other angles of the walling shall be built strictly true and square

Wall Reinforcement

- C. Where so specified hollow block walls shall be reinforced vertically with 10 mm diameter mild steel bars built into the cavities of the blocks at 400 mm centres, unless otherwise specified, all bars in walls to have a minimum lap of 350 mm.
- D. Prices for walling described as reinforced must include for all extra costs involved in slotting blocks over the vertical reinforcement.

Filling of Hollow Blockwork

- E. All cavities where specified and shown above ground and all cavities below ground level shall be filled in solid with concrete of the mix described and placed and consolidated in sections not exceeding 1190 mm in height.
- F. In reinforced walls the filling shall be carefully compacted around the reinforcement.

Blocks to be Wetted

- A All concrete blocks and stone walling shall be well wetted before being laid and the top of walling where left off shall be wetted before re-commencing building. Walls to be kept wet three days after building.

Mortar

- B Mortar to be used for all walling work shall be composed of 1 part of Portland Cement to 1 part lime to 6 parts of fine aggregate measured by volume in specially prepared dry on clean and watertight mixing platforms, with water added afterwards from a can with a fine rose until all parts are completely incorporated and brought to a proper consistency and then used within thirty minutes of mixing, gauge boxes and thoroughly mixed
- C No partially or wholly set mortar will be allowed to be used or re-mixed.

Fair Face Walling

- D Where walling is to be finished with a fair face, the concrete blocks are to be selected for freedom from defects and the joints raked out as the Works proceed and flush pointed with a neat joint in cement mortar.

Joints for Walling

- E The blocks shall be bedded and jointed in cement mortar as described with beds and joints 10 mm thick, full flushed up and grouted solid as the work proceeds. Joints shall be raked out where the surfaces or walling are to be plastered.
- F All walling shall be properly protected while mortar is setting as the Architect shall direct.

Building Walling

- G All walls throughout the Works shall be carried up evenly in 12 mm course, no part being allowed to be carried up more than 800 mm higher at one time than any other part and in such cases the jointing shall

Putlog Holes

- H Putlog holes shall be carefully, properly and completely filled up on completion of walling work.

Rough Cutting etc.

- H. The Contractor shall allow in his prices for the walling which is measured net herein, for all ordinary rough cutting, bonding, plumbing angles, forming reveals and fitting up to under side of concrete beams, slabs and lintels etc.

Stone Pitching

- A The ground to receive pitching shall be well compacted and the stones, which shall be flat bedded and not less than 230 mm either way along the bearing surface, shall be punned to the required falls and inclinations so that neither wedges nor spalls are required to keep the pitching rigidly in place. The joints shall be no more than 13 mm thick and shall be solidly filled with 1:3 cement mortar.

- B Stone for pitching shall be coral obtained from approved quarries. It shall be hard, sound, durable and clean.

Stone for Walling

- C Stone for walling shall be from an approved quarry, roughly square and built random and uncoursed in mortar as described. The stone shall be well bonded with a minimum of one good bond or through stone evenly spaced to each square meter. All cavities and joints in stonework are to be filled in and flushed up solid with mortar.

- D Jointing and pointing is as detailed or instructed.

Precast Screen and Louvre Block Walling

- E Precast concrete screen blocks shall be manufactured in concrete of 30.0 N/mm² strength using 10 mm aggregate, the blocks shall be 390 mm and 190 mm long x 190 mm high and 150 mm on bed in accordance with detailed drawings and finished fair on all surfaces and bedded, jointed and pointed in cement mortar with a neat flush joint.

- F Precast concrete louvre blocks shall be of similar concrete, similarly jointed and pointed and constructed to detail drawing.

Damp Proof Course

- G Damp proof courses shall be hessian based bituminous felt to B.S. 743 Type 5A laid on and including a levelling screed of cement and sand and lapped 230 mm at joints.

ROOFING - ASPHALT WORKS

APPROVED SUPPLIER

- A. All materials shall be supplied by a firm approved in writing by the Architect and the works executed by workmen approved by the supplier.

Guarantee

- B. The Contractor shall deposit with the Architect, a written guarantee and undertaking to the effect that during a period of not less than twelve calendar months from and after the certified date of completion of the whole of the works the contractor shall at his own expense make good to the satisfaction of the Architect all and any defects in the asphalt work which shall be attributed to improper materials or faulty workmanship and shall bear the cost of any consequential damage as shall be provided for in such guarantee.

Samples

- C. The Contractor shall when required by the Architect submit samples of any material for testing.

MATERIALS

Asphalt for roofing

- D. Asphalt for roofing shall comply with B.S. 1162 tropicalised mastic asphalt for roofing purposes.

Felt underlay

- E. The underlay shall be saturated "Cabro" sheathing felt complying with B.S. 1162 (or equivalent).

Insulating screeds

- F. Insulating screeds shall consist of lightweight concrete composed of one part Portland Cement and eight parts vermiculite aggregate and shall be covered with 10 mm cement and sand (1:4) screed wood floated to receive asphalt coverings.

WORKMANSHIP

Preparation of surfaces

- A. All surfaces to receive asphalt and other roof coverings are to be dry, wood floated and finished to suppliers specifications.

Laying

- B. Asphalt and other roof coverings shall be laid in bays generally not exceeding 2 m wide and succeeding coats shall be laid at breaking joint. Junctions between bays and fillets shall be properly married the whole being worked so that the joints are neatly made.
- C. Horizontal asphalt for roof coverings shall be 20 mm thick built up into two layers each 10 mm thick. The first layer shall be applied to sheathing felt and the final coat shall be left ready to receive roofing tiles.

Air pockets and stains

- D. Air pockets and stains on the asphalt and other roof coverings will not be permitted and the finished work shall not ring hollow over any parts of its surface.

Joints and fillets

- E. Joints in all asphalt work and other roof coverings shall be carefully made and complete fusion obtained to make them watertight. Fillets shall be run at all internal angles and in at least two operations. Perfectly watertight joints shall be made around pipes passing through walls and floors etc.

Felt underlay

- F. The felt underlay shall be fixed and laid loose or partially bonded in hot bitumen with but joints.

Testing for falls

- G. To ensure that asphalt and other roof coverings have been truly laid to falls, the contractor is to arrange for the roof areas and gutters to be flushed with water in the presence of the Architect. Any defects or depressions in the asphalt or other roof coverings are to be rectified and retested for approval.

CARPENTRY

Terminology

- A. All technical terms shall be as defined in the "Timber Act (amended 2012)".

Timber Generally

- B. The timber for carpentry and joinery shall be specified and obtained from an approved sawmill.
- C. The timber for carpentry shall be Second or Select Grade for strength.
- D. The timber shall be reasonably straight grained.
- E. All timber for the Works is to be purchased immediately the Contract is signed and is to be open-stacked for as long as possible before use or kiln drying.
- F. All timber as it arrives on the site shall be inspected by the Architect, and any timber brought on to the site and not approved must be removed forthwith.
- G. All timber and assembled woodwork shall be protected from the weather and stored in such a way as to prevent attack by termites, insects or fungi.

Species of Timber for Structural Work

H. The following softwoods shall be used for structural work;

Standard Common Name	Botanical Name
Podo	Podocarpus
Cypress	Cuppressues Lusitanica

- J. Both to be second strength Grade P5 or equivalent. Whilst either timber is suitable, intermixing of species will not be accepted.
- K. The Contractor is permitted to propose substitute species but these shall not be used without the written approval of the Architect and no adjustment shall be made to the basic rates for softwood trusses in the event of a substitute species being accepted.

Insect Damage

- L. All timber shall be free from live borer beetle or other insect attack when brought upon the Site. The Contractor shall be responsible up to the end of the maintenance period for executing at his own cost all work necessary to eradicate insect attack of timber which becomes evident, including the replacement of timber attacked or suspected of being attacked, notwithstanding that the timber concerned may have already been inspected and passed as fit for use.

Seasoning of Timber

- A. All timber shall be seasoned to a moisture content of not more than 18% for carpentry and 15% for joinery. The Contractor's price must include for any kiln drying that may be necessary to achieve these figures.

Pressure Impregnation

- B. The softwood described as pressure impregnated shall be treated with the "Celcure A" "Tanalith C" full cell process. Timber must be seasoned to a moisture content not exceeding 25% before being treated. The treatment shall be to the minimum standard of:-

Solution concentration; 2%
Absorption of preservative; 520 Litres per cubic meter
Net dry salt retention; 10.4 Kg per cubic meter

- C. After treatment, the timber shall be seasoned to the specified moisture content.

- D. Cut ends and faces of timber sawn, drilled and cut after treatment are to be swabbed liberally with approved preservatives until saturated, allowed to dry and then treated with a second coat and rates for timber must include for this. Approved preservatives are: Atlas A; Brunophan Nr 2; Cuprinol Clear or Water Repellant Clear; Ensele Woodtreat 55.

Inspection and Testing

- E. The Architect shall be given facilities for inspection of all works in progress whether in workshops or on site. All timber as it arrives on the site must be inspected by the Architect and any timber brought onto the site and not approved by him must be removed forthwith, failing which he may arrange for the removal of the rejects and dispose of them as he may consider advisable at the Contractor's expense.
- F. Notwithstanding approval having been given above, any timber incorporated in the Works found to be in any way defective before the expiry of the maintenance period shall be removed and renewed at the Contractor's expense. The Contractor is to allow for testing of prototypes of special construction units and the Architect shall be at liberty to select any samples he may require for the purpose of testing, i.e. for moisture content, or identification of species, strength, etc.
- G. Where timbers need to be extended into a wall, they shall be thoroughly "brush treated" with Ensele in addition to preservative treatment as already described above, and as much clear air space maintained around the timber where it adjoins the wall as possible.

Clearing Up

- H. The Contractor is to clear out and destroy or remove all cut ends, shavings and other woodwaste from all parts of the building and the site generally, as the work progresses and at the conclusion of the Work.

Workmanship

- A. All carpentry shall be executed with workmanship of the best quality. Scantlings and boardings shall be accurately sawn and shall be of uniform width and thickness throughout. All carpenter's work shall be left with sawn surfaces except where particularly specified to be wrought.
- B. All carpentry shall be accurately set out in strict accordance with the drawings.
- C. All structural timbers shall be frame or jointed together as is most appropriate in the circumstances in accordance with the rules of good practice. Joints must be executed in strict conformity with the drawings.
- D. All joints shall be secured with a sufficient number of nails disposed as shown on the drawings and rates must include for the jointing of timbers. Surfaces must be in good contact over the whole area of the joint before securing. Holes for nails must be pre-drilled undersize; holes for bolts must be bored slightly over size from both sides of the timber and washers must be used under the nut which must be tightened sufficiently to permanently secure the joint but not to crush the timber.

- E. Actual dimensions of scantlings for carpentry shall not vary from the specified dimensions by more than 3 mm in deficiency or excess but must be uniform throughout. Boards 25 mm thick or less shall hold up to the specified size. All timbers shall be as long as possible and practicable, in order to eliminate joints.

Joints

- F. All nails, screws, bolts, connectors, etc., are to be as specified under "Metalwork" and as shown on the drawings.

General

- A. The provisions contained in the "Carpentry" section shall apply also to the Joinery Section where applicable.

Species of Timber

- B. The following timber of First or Prime Grade for appearance shall be used for Joinery Work in conjunction with the term "softwood" or "approved softwood":-

Standard Name; Botanical Name

Podo (for grounds, etc., only); Podocarpus spp.

African Mahogany; Khaya Nyasica

Mninga, Pterocarpus Angolensis

Iroko (Mvula); Chlorophora excelsa

- C. The following may also be used as "local hardwood" (referred to hereafter) with the Architect's approval:-
Adina; East African Afrormosia; East African Afzelia

Generally

- D. All joinery work shall be accurately set out on boards to full size for the information and guidance of the artisans before commencing the respective works, with all joints, iron work and other work connected therewith full delineated. Such setting out must be submitted to the Architect and approved before such respective works are commenced.
- E. **All joinery work shall be cut and framed together as soon after the commencement of the building as is practicable**, but not to be wedged up or glued until the building is ready for fixing same. Any portions that warp, wind or develop shakes or other defects within six months after completion of the Works shall be removed and new fixed in their place together with all other work which may be affected thereby, all at the Contractor's own expense.
- F. All work shall be properly morticed, tenoned, housed, shouldered, dovetailed, notched, wedged, pinned, bradded, etc., as directed and to the satisfaction of the Architect and all properly glued up with the best quality approved glue.

- A. Joints in joinery must be as specified or detailed, and so designed and secured so as to resist or compensate for any stresses to which they may be subjected. All nails, springs, etc., are to be punched and puttied. Loose joints are to be made where provision must be made for shrinkage; with glued joints where shrinkage need not be considered and where sealed joints are required. Glue for load-bearing joints or where conditions may be damp must be of the resin type. For non-load-bearing joints or where dry conditions may be guaranteed casein or organic glues may be used. All exposed surface of joinery work shall be wrought and all arises "eased-off" by planing and sand-papering to an approved finish suitable to the specified treatment.

Dimensions

- B 3 mm reduction off specified sizes will be allowed for each wrought face except where described as (f) i.e. **finished** size in which case joinery shall hold up to the full dimensions. Dimensions of 25 mm or less shall hold up to the specified sizes.

Fixing Joinery

- C All beads, fillets and small members shall be fixed with round or oval brads or nails well punched in and stopped. All large members shall be fixed with brass screws, the heads let in and pelted to march the grain where natural finish timber is specified.

Mastic

- D Mastic where specified for bedding, joinery, sills, water bars, etc., is to be approved non-hardening plastic, phylsulphide synthetic rubber or butyl composition filler or sealer

Fiberboard

- E Fiberboard shall be "Celotex" or equal and approved.

Plywood

- F Plywood shall be from an approved source and comply with B.S. 1455, first or second grade, as required and unless otherwise stated shall be "interior" quality. Where veneered plywood is specified, samples must be submitted for prior approval. Where stated to be "exterior" quality, this shall be waterproof (Bonding W.B.P.).

- G Routine tests will be required from time to time to check the quality of manufacture. Plywood used in structural members shall be bonded with a suitable adhesive.

Chipboard

- H Chipboard shall be approved medium density resin bonded wood chipboard equivalent to B.S. 2604 with sanded finish or thickness stated. Where faced with plastic sheeting the chipboard shall be counterbalanced.

Blockboard

- J Blockboard shall be laminated board to B.S. 3444. Where faced with plastic sheeting the blockboard shall be counterbalanced.

Flush Doors

- A. Flush doors shall be from an approved source and manufacture, be hollow / semi-solid core constructed generally in accordance with B.S. 459-2 finished with 6 mm veneer plywood (to Architect's approval) and lipped all round with softwood 12 mm thick.
- B. The thickness stated is the overall finished thickness.

Plastic Sheeting

- C. Plastic sheeting shall be Formica or equal and approved laminated sheeting 1.5mm thick fixed with an approved adhesive. All colours are to be selected by the Architect.

Plugging Walls

- D. All work described as plugged shall be fixed with brass screws to plugs formed by drilling concrete, walls, etc., with a proper tool of suitable size at 500 mm spacings and filling the holes completely with an approved proprietary plugging compound used in accordance with the manufacturer's instructions.

Protect Joinery

- E. All fixed joinery which, in the opinion of the Architect, is liable to become bruised or damaged in any way shall be completely cased and protected by the Contractor until the completion of the Works.

Bottom Edges

- F. Bottom edges of doors shall be painted with one coat of approved primer before fixing .

Mosquito Screening

- G. Mosquito screening shall be "Alcad" or equal and approved aluminium fine wire mesh screening.

Bird Screening

- H. Bird screening shall be approved galvanized coffee tray wire.

Ironmongery

- J. All ironmongery shall be fixed with screws to match. Before the woodwork is painted, handles shall be removed, carefully stored and refixed after completion of painting, and locks oiled and left in perfect working order. Prices for fixing locks must include for organizing masterkeying systems if required and all keys shall be labelled with door references marked on approved labels before handing to the Architect on completion.

STRUCTURAL STEELWORK

Standard of Construction

- A. The whole of the structural steelwork and testing shall comply with the relevant clauses of B.S. 449, B.S 4360; 1980 and B.S. 5940 grade 43.

Fabrication by Specialist Firm.

- B. The steelwork shall be fabricated by a specialist firm or under proper factory conditions to be approved by the Architect.

Contractor to Submit Drawings

- C. The Contractor shall include for the preparation of all shop details from the drawing supplied by the Architect. All such details shall be approved in writing, by the Architect, before the work is put in hand. Every drawing shall show the number and sizes of all rivets and bolts, complete details of welds, type of electrodes, welding procedure, whether the welds are to be made in the shop or elsewhere and any other relevant information.

Accuracy of Drawings.

- D. The Contractor shall be responsible for the correctness of his shop details and for shop fittings and site connections.

Erection Scheme

- E. The Contractor shall submit to the Architect for approval, drawings showing the proposed erection scheme, together with all calculations for erection stresses, etc. The approval by the Architect will not absolve the Contractor in any way from his responsibility.

Dimensions to be Verified

- F. The Contractor shall take the dimensions from the site or buildings and he shall verify all dimensions given on the drawings before the work is put in hand.

Copies of Orders

- G. A copy of all orders for materials shall be supplied by the Contractor to the Architect at the time of ordering, for identification purposes.

Damage

- H. Any damage to materials on the site due to inadequate precautions being taken during the erection of the steelwork shall be made good to the satisfaction of the Architect at the Contractor's expense.

Materials**Quality of Steel**

- A. (i) All structural and rivet mild steel shall comply with B.S 4360 Part 2

- (ii) Nil
- (iii) Nil
- (iv) All structural steel tubes shall comply with B.S. 1775 and B.S. 449
- (v) Mild steel and medium tensile steel electrodes for metal-arc welding shall comply with the requirements of B.S. 2549.
- (vi) High tensile steel electrodes for metal-arc welding shall comply with the requirements of B.S. 2549.
- (vii) All mild steel bolts and nuts shall have a tensile strength of not less than 432 N per Square Millimetre (28 tons per square inch) and a minimum elongation of 17 percent as defined in Clause 2 of B.S. 916 or in B.S. 2708.
- (viii) All high tensile steel bolts, nuts and washers shall have a minimum tensile strength of 570 N per square millimetre (37 tones per square inch).
- (ix) High strength friction grip bolts and washers shall comply with B.S. 3139, Part 1.
- (x) All plan washers shall be of steel. Tapered or other specially shaped washers shall be made of steel or malleable case iron complying with B.S. 3410. shall be made of steel or malleable case iron complying with B.S. 3410.

Marking of Steel

- B. Each piece of steel shall be legibly marked with the maker's name or trade mark and with cast numbers or identification marks by which the steel can be traced to the cast from which it was made.
- C. For rivet bars and small pieces securely bundled, a metal tag marked with the cast number will be sufficient.

Standard Dimensions

- D. The dimensions and allied requirements of all structural rolled sections shall comply with B.S. 4. The dimensions, weight, tolerances etc., of all rivets, bolts, nuts, studs, etc., shall conform to the following standards. Rivets shall comply with the requirements of B.S. 275 for dimensions
- E. Black bolts, nuts, studs, lock nuts and washers shall comply with the requirements of B.S. 916 for dimensions and with B.S. 1580 for unified black bolts etc.
- A. Turned bolts shall have the shank turned to the specified diameter allowing only a minus tolerance up to 0.13mm (0.005 inch).

Weight of Steel

- B. For the purpose of measurement, the weight of mild steel shall be as given in B.S. 648 which will be the basis for measurement of variations. The weights per meter given on the drawings do not include the shelf angles riveted to webs, nor the plates riveted to the flanges of R.S. Js or other sections.

Conditions of Surfaces

- C. All surfaces of steel work shall be clean, free from loose millscale and loose rust.

Tests and Inspection

- D. Manufacturer's Mill Test Certificates for all structural steel shall be supplied to the Architect as and when required. Where and when directed by the Architect, the Contractor shall take and deliver samples of structural steel for testing to the Employer's Highways and Transportation Testing Station. Should the results of either test be unsatisfactory the whole consignment of steel which the sample represents shall be rejected and shall be replaced by other material of proper quality at the expense of the Contractor.
- E. The Architect or his representative shall at all reasonable times, be given free access to the Works.

Metallic Coatings

- F. Galvanized steelwork shall comply with B.S. 729 Part 1 entirely coated with zinc after fabrication by complete immersion in a zinc bath in one operation and excess carefully removed. The finished surfaces shall be clean and uniform.
- ii) Zinc sprayed steelwork shall comply with B.S. 2569 Part 1. The nominal thickness of zinc coating shall be not less than 0.102 mm (0.004 inches) and at no point less than 0.076mm (0.003 inches).

Generally

- G. The whole of the fabrication and erection of the steelwork shall be carried out in accordance with B.S. 449

Materials (Cont'd)

- A. The welding of steel to B.S. 1962 must conform to: B.S. 1856 - "General requirements for the metal-arc welding of mild steel" or B.S. 2642 - "General requirements for the arc welding of steel to B.S. 968 and similar steel"
- B. For welding any particular type of joint the Contractor shall provide evidence acceptable to the Architect that the welder has satisfactorily completed the appropriate tests as described in B.S. 5950 - 7
- C. Any welder's tests shall be made at the Contractor's expense and shall include the cost of any fees incurred by the Employer for witnessing of, or making such tests.
- D. The right is reserved to make non-destructive tests on the welding to determine if the welding conforms to the standards laid down in either B.S. 1856 or B.S. 2642 as applicable. This will normally consist of radiography on butt welds, ultrasonic examination of fillet welds or other tests as appropriate to the actual configuration of the weld in question.

Rejection

- E. Any portion of the work which, in the opinion of the Architect, is not in accordance with the drawings, or specification shall be rejected whether before or after delivery and must be removed from the site if delivered within 24 hours from receipt of such notice or rejection at the Contractor's expense. Any delay caused by such rejection will not in any way relieve the Contractor from his responsibility with regard to the provisions of the Contract. If any welding is found to be defective the cost of all remedial measures shall be borne by the Contractor, including the cost of re-testing the subsequent inspection of welds as referred to in the P.C. Sum hereafter.

- F. The Contractor is responsible for the good quality of all welding work and no exceptions will be made on the grounds that the Architect or his representative have inspected any part or parts of the work at some stage during production.

Fabrication

- G. As much of the work of fabrication of the steelwork as is reasonably practicable shall be completed in the manufacturer's works. Field connections shall be made in accordance with the approved drawings. The Contractor shall give four day's clear notice of steelwork ready for inspection at the manufacturer's works, to facilitate inspection before delivery.

Cast of Temporary Erection, etc.

- A. Trial erection of principal or other units may be called for at the discretion of the Architect or his representative.

- B. The cost of any necessary temporary erection, testing, packing, marking, carriage and delivery is deemed to be included by the Contractor in the Tender price.

Joints and Connections

- C. No variation of the number, type or position of the joints or connections shown on the drawings shall be made without the consent of the Architect. If such consent is desired the Contractor shall submit detailed drawings of the proposed joints for the approval of the Architect and no extra cost incurred by reason of such additions or alterations will be allowed to the Contractor.

Painting at Works

- D. Where described as primed at works, steelwork shall be freed of rust, millscale, welding slag and flux residue and shall be dry immediately prior to painting with primer as Clause Q 14 a.

- E. For joints with high strength friction grip bolts the contact surfaces shall be left unpainted but special care shall be taken after assembly to paint all edges and corners near the joints together with bolt head, nuts and washers to prevent the ingress of moisture

- F. For joints made with other bolts and rivets the contact surfaces shall each be given a coat of priming paint and for shop connections the contact surfaces shall be brought together while the paint is still wet.
- G. For welded connections where the contact surfaces are not completely sealed the contact surfaces shall be painted to within 50mm of the edges that are to be welded.
- H. The primer shall be touched up with similar primer if damaged by subsequent handling.

METALWORK

Mild Steel

- A. Mild steel shall comply with B.S. 4360 Grade 1 and the sizes of all small sections shall be in accordance with B.S. 4 and 4A.

Galvanized Work

- B. Iron and steel, where galvanized, shall comply with B.S.1461 Part 1 entirely coated with zinc after fabrication by complete immersion in a zinc bath in one operation and all excess carefully removed. The finished surface shall be clean and uniform.

Aluminium

- C. Aluminium shall be of the alloys described in and shall comply with B.S. 485. Aluminium sheet for flashings shall be soft-temper, super purity (S1 or S1A) and not less than 20 s.w.g. (0.9mm) in thickness.

Smithying, Shearing and Cutting

- D. All smithying, welding, cutting and bending shall be soundly and neatly executed, care being taken not to overheat. All flame cut edges and welds shall be neatly ground off on completion.

Bolts

- E. Mild steel bolts, nuts and washers shall comply with B.S. 916 for black bolts with hexagonal heads and nuts. High tensile steel bolts and nuts shall be in accordance with B.S. 3139 Part 1.

Anchor Bolts

- F. Anchor bolts in concrete for steel works etc., are to be self drilling anchor bolts of one of the following types:-
- Phillips redhead concrete anchors
 - Rawlplug super drilanchor
 - Spit self-drilling anchors
- G. Rates are to include for fixing complete with washer. Mortices in concrete have not been measured for this item.

Shop Inspection

- A. The Architect shall be granted full facilities and any necessary assistance for inspection or materials and assembled parts in the Contractor's (or his Sub-Contractor's) workshops. At least two weeks notice shall be given to the Architect in writing prior to the despatch of finished components to the site to enable the Architect to inspect and approve the materials and workmanship at the workshops. Approval of work at the workshop does not relieve the Contractor of this obligations to carry out the work complete at the site to the Architect's satisfaction in accordance with the Contract.

Marking

- B. All components delivered to the site are to be marked in paint with the Mark number in accordance with any shop and erection drawings.

Storage

- C. All components are to be stored at the site in proper racks provided for the purpose which provide full support to each member to obviate any deflection and distortion. Steelwork is to be stored at least 25cm clear of the ground and temporary protection is to be provided for protection against water and damage from any other source.

Erection

- D. Rates for all metalwork are to include for the complete for the complete erection including any temporary supports required and any necessary templates and wedges.

Painting

- E. All steel is to be thoroughly de-rusted and degreased prior to despatch to the site and is to be given one coat zinc chromate primer at the works. Further painting treatment will be carried out at the site. Painting is measured separately and the cost thereof is not to be included in the rates for metalwork.

PLUMBING AND ENGINEERING INSTALLATION

Execution of the Works

- A. The work shall be carried out strictly in accordance with:-
 - (a) "British Standard Code of Practice" C.P. 310: 1965: Water Supply
 - (b) "British Standard Code of Practice" C.P. 404: 1968: Sanitary Pipework above ground
 - (c) All other relevant British Standard Specifications and Codes of Practice
 - (d) Bye-laws of the Local Authority
 - (e) The working drawings

Extent of Work

- B. The Contractor will be responsible for all below ground plumbing and drainage work and the installation of the Sanitary Fittings only, the remainder of the Plumbing and Engineering Installation will be executed by a Nominated Sub-Contractor.

Quality of Materials and Workmanship

- C. All materials, equipment and accessories are to be new and in accordance with the requirements of the current rules and regulations where such exist, or in their absence with the relevant British Standard Specification.
- D. Uniformity of type and manufacture of equipment or accessories is to be preserved as far as practicable throughout the whole work.
- E. The Contractor shall, if required by the Architect, submit samples of materials to the Architect for his approval before placing an order.

- F. If in these Preambles the practice is adopted of specifying a particular item as "similar" to that of a particular firm's product, it is to be clearly understood that this is to indicate the type and quality of the equipment required. No attempt is being made to give preference to the equipment supplied by the firm whose name or product is quoted.
- G. Where particular manufacturers are specified herein, no alternative makes will be considered and the Architect shall be allowed to reject any other makes.
- H. The Contractor will be entirely responsible for all materials, apparatus, equipment, etc., furnished by him in connection with his work, and shall take all special care to protect all parts of finished work from damage until handed over.
- J. The work shall be carried out by competent workmen under skilled supervision. The Architect shall have the authority to have any of the work taken down or changed which is executed in an unsatisfactory manner.

Galvanized Steel Tubes and Fittings

- A. Galvanized steel tubing shall comply with B.S. 1387 with plain galvanized malleable fittings complying with B.S. 143/1256.
- B. Tubes and fittings shall be jointed by means of screwed threads to B.S. 21, by means of P.T.F.E., tape or hemp and "Bosswhite". All joints shall be perfectly smooth inside without excrescences.
- C. Where sleeves are required for pipework passing through concrete, blockwork or below concrete slabs, they shall be galvanized steel tube or drain pipes of sufficient diameter to give at least 25mm clearance all round the water main.
- D. Galvanized water mains below ground level or below slabs shall be double wrapped in "Denso" tape.

Brasswork

- E. Stop valves shall comply with B.S. 1010 and shall be with crutch handles or loose keys where so described on the drawings. Draincocks shall comply with B.S. 2879.

Testing

- F. Upon completion the whole of the water main shall be tested to a pressure not less than twice times the working pressure for a period of thirty minutes.
- G. Notwithstanding the foregoing clauses, all water mains and fittings and installation thereof shall comply fully with the requirements of the Water Supply Authority.

Sanitary and Other Appliances

- H. The appliances shall be fixed in the positions shown on the drawings or as described by the Architect.
- J. The Contractor shall include in his rates for providing all necessary screws, bolts, etc., together with all jointing materials required and also for temporarily erecting and securing fittings in the required position or service and discharge pipes, taking down, storing and fixing after completion of wall finishings permanently fixing and connecting to service and discharge.
- K. Care shall be taken at all times and particularly after fixing, to protect appliances from damage.
- L. Upon completion of the work, all appliances shall be cleaned of plaster, paint, etc., and carefully examined for defects.

Fire Fighting Equipment

- A. The specified fire fighting equipment shall be supplied and installed by the Contractor in the positions shown on the drawings
- B. Portable fire extinguishers shall comply with the following British Standards:-
 - (a) Water type (soda acid); B.S. 138: 1948
 - (b) Foam type (chemicals); B.S. 740: Part 1: 1948
 - (c) Foam type (gas pressure); B.S. 740: Part 2: 1952
 - (d) Water type (gas pressure); B.S. 1382: 1948
 - (e) Carbon tetrachloride and chlorobromethane; B.S. 1721: 1960
 - (f) Carbon dioxide type; B.S. 3326: 1960
 - (g) Dry powder type; B.S. 3465: 1962
 - (h) Water type (store pressure); B.S. 3709: 1964
- C. Fire hose couplings and ancillary equipment shall comply with B.S. 336: 1965; rubber reel hose shall comply with B.S. 3169: 1959.
- D. Underground fire hydrants and surface box openings for same shall comply with B.S. 750: 1964.
- E. The installation of hydrants and fire extinguishers shall be in accordance with C.P. 402:101: 1952 and C.P. 402 part 3: 1964 respectively.
- F. If nothing else is specified, fire extinguishers and hose reels shall be supplied in the colour "fire red" and be similar to manufacture "ANGUS".

FLOOR WALL AND CEILING FINISHINGS

Sand

- A. Sand for backing, floor and wall finishes is to comply with B.S. 13139, Table 1.

Cement

- B. Cement is to be as described for "Concrete Work:."

Lime

- C. Lime is to be no-hydraulic hydrated lime to B.S. 459 Class "A" obtained from an approved source and run into putty at least 24 hours before use.

Workmanship

- D. All concrete beds or slabs shall be thoroughly brushed clean, hacked if necessary and well wetted and flushed over with a cement sand (1:1) grout immediately before screeds or pavings are laid.
- E. Screeds and cement pavings shall be laid in accordance with the relevant B.S. Code of Practice. Working joints between bays of the floor finish should be placed in accordance with the Architect's instructions and will be plain butt joints placed over joints in the concrete bed under. Pavings shall be damp cured with sand or sawdust and kept damp for at least 7 days after laying.
- F. All surfaces to be plastered or rendered must be brushed clean and well wetted before plaster is applied. Joints of walling shall be raked out and concrete hacked to form a key. Care shall be taken to see that paving and plastering do not dry out prematurely.
- G. Adequate time intervals must be left between successive coats in two-coat work in order that the drying shrinkage of the undercoat may be substantially complete. All internal and external angles shall be pencil rounded.

In-Situ Pavings Generally

- H. Before laying in-situ floor finishes, the concrete beds are to be thoroughly hacked for key, cleaned off, thoroughly wetted with clean water and coated with a stiff cement slurry and rates for screed, granolithic and terrazzo paving are to include for this. They are also to include for all necessary curing and protecting until the building is handed over.

Cement and Sand Paving

- J. The cement and sand paving shall be in proportions of 1:4 by volume and incorporating or treated with an approved hardener.

Polished Granolithic Paving

- A. The aggregate for granolithic paving shall be in accordance with B.S. 1201 and shall be mixed in the proportions of 1:1:1.50 cement, fine and coarse aggregate respectively. The mix shall incorporate an approved hardener suitable for incorporation and not for surface treatment. The water cement ratio shall be kept as low as possible and shall not in any case exceed 0.45. The paving is to be laid to the full thickness described and to be finished with a wood float and with no extra cement trowelled into the surface which is to be laid true and level. The paving is to be thoroughly cured after laying by covering with polythene sheeting and periodically watered to keep it moist for at least one week after laying. The surface is to be polished with approved rotary carborundum discs mechanically operated coarse and fine grain and with cement and sand slurry to produce a blemish-free surface.

- B. The granolithic shall be laid in bays not exceeding 3.50 square meters with ebonite dividing strips for the full depth of the paving and shall be executed by Specialist who have a thorough knowledge of the work.

Polished Terrazzo Paving

- C. The ins-Situ terrazzo shall consist of white or coloured cement and marble aggregate; the colours of the cement and aggregate shall be selected by the Architect. The mix shall comprise three parts of 6mm nominal aggregate to one part coloured cement by volume. The aggregate shall be clean and granular and shall not contain flaky particles or dust. The underbed shall be cement and sand 1:4 by volume.

- D. The terrazzo shall be laid in bays not exceeding 3.5 square meters with ebonite dividing strips for the full depth of the terrazzo and underbed, and shall be executed by Specialist who have a thorough knowledge of the work.

- E. The terrazzo topping shall be laid to a minimum of 12mm thickness in a plastic condition while the underbed is still green and this should be watered to minimise absorption from the topping. The terrazzo must be well tamped into position and rolled with a suitable hand roller. The topping should be allowed to take an initial set and then any surface voids must be grouted up with neat cement of the same colour used in the mix. The surface should be cured by keeping moist by covering with damp sacking for at least 72 hours. When dry and hard the surface shall be machine polished by grinding with carborundum or other stone discs of suitable grade and with rotary polishing pads.

- F. Rates must include for all necessary protection until the building is handed over to the Architect. The depths stated are for the full depth including topping and underbed.

P.V.C. Flooring and Skirting

- G. P.V.C. floor tiles shall comply with B.S. 10595. The tiles and accessories shall be supplied in the sizes and thickness specified in colours selected by the Architect and are to be fixed to the screed base with a suitable adhesive supplied (or recommended) by the Manufacturer and used in accordance with his instructions. Rates for floor tiles shall include for thoroughly washing and cleaning on completion and for the application of one coat of water based wax polish.

Brushed Terrazzo Rendering

- A. Brushed terrazzo rendering is to comprise two coats as described. The undercoat shall consist of cement and sand mixed in the proportion of (1:4) by volume and applied to a minimum thickness of 10mm finished with a wood float and scratched to provide key for top coat. The finishing coat shall consist of one part white cement to two parts marble chippings or approved size applied to a minimum thickness of 10mm and the final surface wet brushed to expose the aggregate.
- B. The Contractor will be required to produce a sample panel of rendering on site for the approval of the Architect.

Internal Plaster

- C. Internal plaster shall be applied in two coats and adequate time intervals must be allowed between successive coats in order that the drying shrinkage of the undercoat may be substantially complete. The first coat must be well scratched, keyed and wetted to receive the finishing coat. The finishing coat shall be finished smooth with a steel float but care must be taken not to overwork the surface in order to minimize the incidence of shrinkage cracks. All internal and external angles shall be pencil rounded.
- D. Internal plaster, unless otherwise described, shall be lime plaster of 12mm minimum overall finished thickness applied in two coats, the first coat consisting of cement, lime putty and sand mixed in the proportion of 1:2:9. The finishing coat shall be a skim coat comprising cement and lime putty in the proportion of 1:10.
- E. Cement plaster is to be employed where specified on the drawings and is to be applied in two coats of approximately equal thickness to a total of 12mm minimum overall finished thickness. The composition of both coats shall be the same and shall comprise cement and sand (1:3) but a small percentage addition (not more than 10%) lime putty may be permitted if the Architect considers that this will reduce the incidence of shrinkage cracks.
- F. The Contractor shall cut out and make good all cracks, blisters and other defects and leave the whole of the plastering and rendering perfect at completion. When making good defects the plaster shall be cut out to a rectangular shape with edges undercut to form dovetailed key, and all finished flush with the face of surrounding plaster.

Marmoran Finishings

- G. Prepare and prime surface, apply one coat 3 mm thick PVC Resin Bonded plaster with trowel, apply 3.2 mm thick stone chips with low pressure spray gun or by hand, roll flat by roller immediately after application. Colours and texture of the plaster and stone chips are subject to specifier's approval. Specifications must be strictly in accordance with manufacturer's instructions.

Wall Tiles

- A. Glazed wall tiles shall be from an approved manufacturer and shall conform with the requirements of B.S. 1281. Tiles shall be white with slightly rounded or "cushion" edges and unless otherwise specifically described shall be size 150 x 150 x 6mm thick. Tiles shall be laid with continuous straight joint and internal angles shall be butt jointed. Rounded on edge tiles shall be used at all external angles and at edges of panels. Tiles shall be bedded in approved tiles adhesive and pointed in white cement.
- B. Backing to tiles is to be cement and sand in the proportion of 1:4 rendering in one coat to a minimum thickness of 12mm trowelled smooth. Backings have been measured separately.

Carpet Tiles

- C. Carpet floor tiles shall be from an approved manufacturer and shall conform to specification as per M/s Protex of South Africa. Graveltex Protex Carpet tiles shall be of heavy duty grade, 100% stain proof miracle fibre with density of 920, g/sq.m (fibre) and 4500 g/sq.m (total) with fire resistance (S.A.B.S) of 3, lavender colour. The size shall be 500 x 500 x 9.50mm thick. Tiles shall be laid with continuous straight joint. Tiles shall be bedded in approved tiles adhesive.
- D. Beds to tiles are to be cement and sand in the proportion of 1:4 rendering in one coat to a minimum thickness of 30mm trowelled smooth. Backings have been measured separately.

Floor tiles

Porcelain tiles

- E. Porcelain floor tiles shall be from an approved manufacturer and shall be of black polished, cocowhite-polished or gardenia green matt. The size shall be size 400 x 400 x 10 x thick. Tiles shall be laid with continuous straight joint. Tiles shall be bedded in approved tiles adhesive.
- F. Beds and backings to tiles is to be cement and sand in the proportion of 1:4 rendering in one coat to a minimum thickness of 30mm trowelled smooth. Beds and backings have been measured separately.

Laying of Marble, Granite, Porcelain or Ceramic Floor Tiles

- G. Before laying the tiles, level the flooring area, ensure the surface is rough and clean.

Laying Floor tiles with Traditional Mortar

- H. The cement thickness needed to lay tiles should be around 40 mm. The mixture for indoor is 1 volume of Portland cement and 3 volumes of sand. The mixture must be made with appropriate quantity of water in order to dampen the materials. Clean and wet the flooring area, making sure to leave completely clean. Spread the mixture and level with a ruler, in order to reach the 40 mm of thickness. Spread dry cement over the mixture, until the water that remains over the surface has been completely absorbed. Lay the tiles, already mixed from different boxes, with a wide joint and in the desired way. Wet tiles, then cover to achieve a perfect level.

Laying Floor tiles with Adhesive

- A. The bed needed for this kind of laying, should be around 30 mm. The flooring area should be steel or wood trowelled and levelled. Spread the adhesive with a spatula with ridges. It is very important to lay a good quantity of adhesive so that there is no free space between the tiles.

Mixing the Colour Shades of Floor tiles

- B. Before laying the tiles at least 5 to 6 boxes must be laid over a dry surface in order to ensure that the different shades have a uniform look. The best result is obtained this way.

The Joints of Floor tiles

- C. The tiles have to be laid with a minimum of at least a joint separation between tiles of 3 to 10 mm.

Setting the Joints of Floor tiles

- D. The cord or wire system can be used in the 4 or 5 joints, ensuring they are all parallel with the reference joint. Plastic crosses used for this purpose, in different sizes, can be obtained in specialized shops, giving a much better finishing and final result.

Filling the Joints of Floor tiles

- E. Apply a mixture composed of 2 volumes of Portland cement and 1 of fine washed sand, with enough water in order to amplify the handling. There are suitable preparations for different uses and in different colours now available, so as to achieve the desired effects. Spread the substance by use of a rubber or plastic spatula. Clean the tiles before the mixture dries. After the joints are completely dry, wash with plenty of water several times.

Concrete Tiles

- F. Concrete tile for finishing the roofs shall be 25mm thick of natural colour with bevelled top arises on all sides and shall comply with B.S. 1197. The tiles shall be laid to regular pattern with open joints. Care should be taken to ensure that the surface level is even and follows accurately the levels of the roof finish. All cement stains shall be carefully removed.

Precast Concrete Paving Slabs and Kerbs

- A. Precast concrete paving slabs shall comply with B.S. 368. precast concrete kerbs shall comply with B.S. 340 figure 5 and shall be finished true and smooth on all exposed faces.
- B. Precast paving shall be bedded on a compacted sand bed with 6mm wide joints filled and pointed with cement mortar coloured to match the colour of the slabs. The pavings shall be finished true and even and to the falls shown with no surface irregularities.

GLAZING

Method of Glazing

- C. Notwithstanding reference in the descriptions of glazing method to glazing beads, or the like with associated fixings, and insulating strips, such components will be measured separately in accordance with the appropriate rules of the S.M.M.
- D. The provision of glazing compounds and putties and springs, clips and other sundry fixings shall be deemed to be included with all items of glazing.
- E. Distance pieces and setting blocks, in appropriate materials, shall be provided in accordance with good glazing practice and they shall be deemed to be included with all items of glazing.

MATERIALS

Glass generally

- F. All glass shall comply in all respects with the appropriate section of B.S. 952. Plain sheet clear glass shall be O.Q.; plate glass shall be GG. All glass shall comply in all respects with the latest British Standards including the British Codes of Safety.

Putting for glazing to wood

- G. Putty for glazing to wood shall comply with B.S. 544.

Samples

- H. Samples not less than 150 mm square, are to be submitted to the Architect for approval before any glass is cut.

WORKMANSHIP

Glass to be kept free from moisture

- J. All glass surfaces shall be kept dry during transit and storage. Glass becoming moist from condensation or other causes, shall be thoroughly dried and aired.

Rebates and beads

- A. All glazing beads in wood shall be primed, (as measured in Painting and Decorating), before glazing is commenced.

Edges of glass

- B. All glass shall have clean cut edges. The edges of louvres shall be rounded and

Bead glazing

- C. Glazing fixed by beads shall have both glass and beads bedded and back puttied, and the putty trimmed off flush. Where sealing strip is used, it shall pass round both faces of the glass and be trimmed off flush on both sides. Metal surfaces to receive sealing strip shall be treated with mineral oil before glazing.

Method of measurement

- D. Beads and sealing strips have been measured separately. Prices for glazing with beads are to include for taking out and re-fixing beads as required, which shall be deemed to be bradded unless otherwise described.

PAINTING

Execution by a Specialist Firm

- E. All work under this section must be executed by a Specialist Firm, approved by the Architect.

Approved Paints

- G. All paints shall be obtained from the same manufacturer and shall be approved by the Architect.
- H. The Contractor must allow for providing the Architect with colour charts from the approved firm and for executing sample panels as required.

Generally

- I. All materials shall be delivered on site intact in the original drums or tins and shall be mixed and applied strictly in accordance with the manufacturer's instruction and to the approval of the Architect.
- J. The only addition which will be allowed to be made locally will be liquid thinners and driers supplied or recommended by the manufacturers and none shall be thinned more than approved by the Architect.

Preparation

- K. All surfaces to receive treatment are to be clean and dry before paint application and surface irregularities are to be removed by filling or the use of suitable abrasives.

External Rendered Surfaces

- A. External cement slurry finished wall which are to be painted must be clean and must be thoroughly brushed and washed to remove any dust, loose flakes or other foreign matter and must be well wetted prior to the application of finish.

Plastered Surfaces

- B. Internal plastered surfaces which are to be painted are to be allowed to dry out thoroughly prior to paint application. All cracks and surface imperfections are to be cut back and filled with a patent filler in accordance with the manufacturer's instructions and rubbed down to a true and even surface.

Woodwork Preparations

- C. Large knots in woodwork are to be cut and replace with sound wood or scorched back and after priming the surface made good with stopping. All knots are to be treated with two thin coats of patent knotting free from resin. After priming, all nails holes and other imperfections shall be filled with stopping and the whole surface rubbed down to a smooth even finish. The stopping must be "Sadofill" or other approved make.

Woodwork - Fittings

- D Unless otherwise specified, fittings are to be treated with two coats of linseed oil.

Metalwork

- E All rust and loose scale on steel and iron work must be removed by wire brushing and rubbing with emery paper. Where patches of ingrained rust cannot be removed they are to be thoroughly rubbed down and treated with one coat of "Galvafroid" or other zinc rich paint in accordance with the manufacturer's instructions. One coat of zinc chromate primer will then be applied followed by two undercoat and one finishing coat of gloss paint as described for Woodwork above. The Contractor is tonote that where mild steel burglar bars are housed into wood frames, the full length or the bar is to be treated before fixing.

- F Galvanized metalwork is to receive one coat of white spirit or mordant degreasing solution washed off prior to the application of calcium plumbate primer followed by two undercoats and one finishing coat of gloss as previously described.

- G Galvanized metal work is to be painted only where instructions are given by the Architect as in some cases galvanized metalwork is to be left untreated.

DRAINAGE

Generally

Preambles to Other Sections

- A The preambles contained in other sections of this document shall apply equally hereto where applicable, so far as is consistent with the clauses following.

Notices

- B The Contractor shall give all requisite noticed. Uncoloured plans will be supplied by the Architect at the Contractor's request.

Drainage Bye-Laws

- C All of the works shall comply with the requirements of the drainage bye-laws made by the Local Authority and shall be executed to the satisfaction of the Architect and Local Authority.

Inspections

- D The Contractor shall give written notice to the Architect for the purpose of inspections and measurements, whenever section of:-

- (a) excavations are completed
- (b) concrete beds are laid
- (c) drains are completed

and no further work shall be executed until each stage of the work has been inspected.

Levels of Existing Drains

- E The Contractor shall check the invert levels of existing drains, sewer and manholes before laying new drains, and shall notify the Architect immediately if the declared invert levels are found to be inaccurate

Pitch Impregnated Fibre Drain Pipes, Couplings and Fittings

- F Pitch impregnated fibre drain couplings and fittings shall comply with B.S. 2760.

UPVC Pipes and Fittings

- G UPVC pipe and fittings shall comply with B.S. 3506 Class O to be obtained from a manufacturing source approved by the Architect in writing.

Spun Cast Iron Drain Pipes and Cast Iron Fittings, Gullies etc.

- H Spun cast iron drain pipes shall be coated centrifugally cast (spun) iron pipes complying with B.S.1211 Class B.
- A Fittings, gullies, etc., shall be of coated cast iron and shall comply with B.S. 1130.

Concrete Pipes and Fittings

- B Concrete pipes and fittings shall comply with B.S. 556. They shall be reinforced, and of sulphate resisting cement if specified.

Manhole Covers and Road Gratings

- C Manhole covers and road gratings and frames shall comply with B.S. 497.

Step Irons

- D Step irons shall be galvanized malleable cast iron complying with B.S. 1247.

Mesh Reinforcement

- E Mesh reinforcement shall be steel fabric complying with B.S. 1221 Part A or B.S. 4483.

Setting Out

- F The Contractor shall set out all drains in accordance with the drawings, and provide all profiles, etc., necessary for the execution of the work.

Excavation

- G The bottoms of all excavations shall be trimmed and consolidated to the correct levels. Unauthorized excavations below the required levels shall be filled with concrete of the same composition as for drain beds, at the Contractor's expense.

- H Where the bottom is insufficiently firm, the Contractor shall excavate until, in the Architect's opinion, a firm bottom is obtained and the level shall be made up with concrete of the same composition as for drain beds. Particulars of such additional work shall be agreed with the Architect's representative before the work is covered up, otherwise no claim in this respect will be entertained.

Planking and Strutting

- I Care shall be taken not to undermine the foundations of the buildings and, if so directed by the Architect, planking and strutting shall be left in, or other means adopted to protect the foundations. Details of such additional items shall be agreed with the Architect's representative before the work is covered up, otherwise no claim in this respect will be entertained.

Backfilling

- J Trenches for pitch impregnated fibre of UPVC pipes shall first be filled with selected screened excavated materials carefully hand-tamped between the pipe and sides of the trench, followed by 150mm - 200mm of similar materials before the general filling is carried out.

- A Trenches for concrete or cast iron drains shall first be filled to a depth of 300mm with selected fine materials carefully hand-packed around the pipe. On no account shall materials be tipped into the trench until first 300mm has been completed.

- B Filling shall be continued in layers not exceeding 300mm thick, well rammed and, if necessary, watered.

Laying Drains

- C Drains shall be laid truly straight on line and gradient with sockets upstream and the full bore shall be unobstructed.

Pitch Impregnated Fibre Drains

- D All hard obstructions shall be removed from trench bottoms before laying pitch impregnated fibre pipes. The pipes shall be bedded in sand and laid and jointed in accordance with Appendix "C" to B.S. 2760.

UPVC Drains

- E UPVC drain pipes shall be laid and jointed with solvent welded joints entirely in accordance with the manufacturer's instructions.

- F Pipes shall be bedded in sand after all hard obstructions have been removed from trench bottoms.

Cast Iron Drains

- G Cast iron drains shall be laid on concrete beds where specified or shown on the drawings and shall be jointed with gasket of hemp, well caulked, to a depth of 30mm for 100mm pipes and 40mm for large pipes, and remainder of the socket shall be filled with molten lead or lead fibre solidly caulked.
- H Connection of iron to concrete drains shall be jointed as described for concrete drains.
- I Cast iron drains fixed to walls or beams shall be supported on brackets at 1,350mm centres.
- J Gullies, outlets, etc., on drains under concrete floors shall be set in position at correct levels before the floors are laid.

Concrete Drains

- K Concrete drains shall be jointed with one turn of tarred gaskin, well caulked and the remainder of the socket filled with cement and sand (1:3), finished with an angle fillet around the pipe. All surplus mortar shall be removed from the inside of the pipe with a badger. Where pipes are sulphate resisting, the jointing mortar shall contain sulphate resisting cement.

Concrete Beds, Haunches and Coverings

- A Where specified or shown on drawings, drains shall be laid on concrete, (105kg/sq.cm - 40mm aggregate), beds 100mm thick, 400mm wide for 100mm diameter drains and 450mm wide diameter drains. The concrete shall be haunched up both sides of the barrel to give lateral support.
- B Where drains, other than cast iron drains, are laid under buildings or pavings carrying vehicular traffic, they shall be completely surrounded in concrete, (105kg/sq.cm - 40mm aggregate), 150mm thick, (i.e. 400mm x 400mm overall for 100mm pipes and 450 x 450mm overall for 150mm pipes). Where directed, drain beds shall be reinforced.
- C Gullies shall be bedded and surrounded in concrete 105kg/sq.cm - 40mm aggregate minimum 150mm thick all round.

Sleeves

- D All drains passing through walls or foundations shall have sleeves of cast iron pipe of sufficient size to allow a clearance round the drain.

Benching

- E Benching in bottom of manholes shall be concrete (105kg/sq.cm - 40mm aggregate) to falls of not less than 10 degrees to channels finished with cement and sand (1:2), 25mm thick, trowelled hard and smooth with all angles rounded.

Bedding and Sealing Covers and Frames

- F Frames to manhole covers shall be bedded in cement mortar (1:3), and the covers in grease and sand.

Testing

- G All drains and manholes shall be tested for water tightness and straightness to the satisfaction, and in the presence of, the Architects and the Local Authority. Drains shall be filled with water to a head of 1.50 meters and are to be tested in sections agreed with the Architect:-

- (i) after jointing
- (ii) after haunching and backfilling
- (iii) after completion of the works

- H The Contractor shall provide all necessary testing apparatus and shall carry out such other tests as are required by the Architect and the Local Authority.

Clean and Flush all Drains

- I All drains, gullies, manholes, etc., shall be cored, cleaned and flushed on completion.

Method of Measurement

- A Where not otherwise stated, the starting level for trench manhole excavation shall be:-

- (i) the formation level in areas where the site is excavated to reduce levels.
- (ii) existing ground level in areas where no excavation is required, or where filling is required.

- B The depths of all the trenches in the following description lie within the same 1.5m stages as the average depths stated.

- C Prices for excavating pipes trenches shall be deemed to include keeping them free from general water (i.e. all water except spring or running water).

- D Notwithstanding the provisions of SMM Clause V.7 (a) to (c) the descriptions of excavating manholes, yard gullies, septic tanks and soakpits shall be deemed to include grading bottoms, planking and strutting, return filling and compacting, disposal of surplus soil and keeping excavation free from water.

- E Prices for building pipes into manholes shall include for building in on rake where necessary.

- F Prices for concrete beds, benchings and covering for pipes laid in trenches, shall be deemed to include for any necessary formwork. Formwork required for beds, etc., for pipes above ground, and for casing to vertical pipes, is referred to in the descriptions of such items.

- G Prices for all gullies shall be deemed to include for all necessary excavation, return filling, disposal of surplus excavated materials, planking and strutting, and trimming and ramming bottoms.

EXTERNAL PAVINGS

Generally

- A. The Preambles contained in other sections of the document shall apply equally to this sections so far as is consistent with the following clauses.

Materials

Soil for Planted Areas

- B. Soil for planted areas shall be vegetable soil free from roots and rubbish and treated with weed killer to prevent the growth of weeds.

Sand for Filling under Footpaths

- C. Sand for filing under footpaths shall be clean, dry, pit or river sand, free from vegetable soil, roots and rubbish.

Crusher Dust for Sub-Base Course of Macadam Paving

- D. Crusher dust shall be from an approved source and shall be free from clay or other deleterious matter.

Stone for Base Course to Macadam Paving.

- E. Stone for base course to macadam paving shall be 40mm gauge, clean and hard and free from clay or other deleterious matter.

Blinding For Stone Base Course

- F. Blinding for stone base course shall be 4mm gauge hard stone chippings, free from clay, dust or other deleterious matter.

Precast Paving Slabs

- G. Precast paving slabs shall comply with B.S. 368 except for sizes.

Kerbs

- H. Precast concrete kerbs shall comply with B.S. 340, and shall be finished true and smooth on all exposed faces.

Prime Coat for Macadam Paving

- J. The prime coat for macadam paving shall be bitumen grade M.C.I.

Bitumen for surfacing

- A. The bitumen for surfacing shall be made 500/700 grade bitumen.

Workmanship

Generally

- B. The sub-grade, sub-base and base courses for roads and parking area shall be prepared and laid at a convenient time before completion of the contract, as shall be agreed between the Architect and the Contractor, together with their kerbs and foundations

- C. The wiring course shall be applied at a later date, and prior to laying, the base course shall be made good in accordance with the requirements specified herein. The Contractor shall make good at his own expense any damage to kerbs.

Surveying

- D. The Contractor shall verify all dimensions and levels prior to the commencement of work.
- E. All surveying necessary for the accomplishment of the works shall be done by the Contractor at his own expense and he shall give notice of his intention to carry out such work in order that the arrangements can be made for supervision and checking. The Contractor shall also provide, without extra charge, all necessary instruments, appliances, labour and any other materials required for checking the survey work.
- F. The Contractor shall make all necessary surveys using given bench marks as reference points. These bench marks he shall carefully preserve.
- G. The Contractor shall draft, in accordance with these surveys, all plans and drawings which are necessary for the completion of the work, and shall submit these plans and drawings to the Architect for approval in writing.

Levels, Falls, Crossfalls and Cambers

- H. The works shall be executed to the levels, falls, crossfalls and cambers shown on the drawings

Accuracy

- J. The Contractor shall be responsible for ensuring that the works are carried out to the line, levels and dimensions shown on the drawings, and shall provide camber gauges and straight edges for checking to ensure that the surfaces are within the following tolerances:-

- (a) **Sub-Grade**

The camber or crossfall shall not vary more than 20mm from that shown on the drawings. In the longitudinal direction the variations from a 3 meter straight edge placed parallel to the centre line of the road shall not exceed 12mm.

- (b) **Base**

The camber or crossfall shall not vary more than 12mm from that shown on the drawings. The variation on the longitudinal section shall be as above for sub-grade

Sub-Grade

- A. The sub-grade shall be shaped to the required falls and cambers and any depressions filled with approved materials having a minimum C.B.R. of 8 percent. This value shall be obtained at optimum moisture content and compacted to 100 percent of the maximum dry density as determined by B.S x1377. The Contractor shall carry out standard compacting tests on the sub-grade in accordance with Test Nr 10 of B.S. 1377. Such tests shall be taken at 30metre intervals. The standard of compaction required shall be 98 percent of the maximum dry density as determined by Test No. 9 of B.S. 1377.
- B. The sub-grade shall be approved by the Architect before any materials to be used in construction of the carriageway are deposited or laid.

Sub-Base Course

- C. The sub-base shall consist of a layer of crusher dust finishing to the thickness specified after compaction. The bed shall be watered as necessary and rolled to produce a smooth and uniform surface with no irregularities.

Base Course

- D. The base course shall consist of a layer of stone in which the interstices shall be filled by application of crusher fines after the stone is in place, to finish to the thickness specified after compaction. The base course shall not be blinded with crusher fines, but with 4mm gauge stone chippings to provide a clean hard surface. If any irregularities develop, they should be corrected by loosening the material at these places and adding or removing material and recompaction until the surface is smooth and uniform with no irregularities.

Application of Bitumen

- E. The plant used by the Contractor for transporting, heating and spraying bitumen shall be in suitable rubber-tyred units and shall ensure adequate and uniform heating without the introduction of steam or moisture, and giving rise to the cooking or burning of the bitumen, and shall be fitted with a thermometer and heating control. Distributors shall be equipped to provide a constant rate of application per square meter of surface and there shall be visible speedometer indicating the speed of the vehicle in meters per minute.
- A. Spray bars shall be capable of spreading the bitumen evenly to the full width of the work. The bitumen shall be heated to the temperature specified below and sprayed on the clean surface of the base at the rates specified.
- B. Application temperatures shall be in accordance with those recommended by the manufacturer, or where this information is not available, they shall be as follows:-

Bitumen Grade	Sprayed Temperature (Degree Celcius)
N.C.I	54-80
500/700	124-140

Prime Coat

- C. Prior to the application of the prime coat, the surface of the base shall be swept clean of dust and foreign materials to the satisfaction of the Architect. Approximately 30 minutes before applying the bitumen the surface of the base shall be lightly sprayed with water.
- D. The prime coat shall be applied at the rate of 0.70 litres per square meter.

Wearing Course

- E. After the application of the priming coat, and where directed and approved by the Architect, the Contractor shall lay bitumen type 500/700 spread at the rate of 3 square meters per 5 litres immediately followed by spreading dry, clean approved 12mm chippings at the rate of 130 square meters per cubic meter, rolled six to eight passes of a six to eight tonne roller. A second and similar surfacing layer shall be laid at the end of the defects liability period.
- F. Alternatively, where specified, the wearing course shall consist of a premix macadam carpet of 500/700 grade bitumen and approved quality aggregate graded and mixed together prior to laying in the proportions and by the methods given in B.S. 1621 table 4, laid to finish to the thicknesses shown after compaction. The compaction shall be achieved with six to eight passes of a six to eight tonne roller.

Wet Weather

- G. No bitumen spraying shall be carried out when either the carriageway surface of the aggregate are wet, without the prior approval, in writing, of the Architect who may allow such work to proceed by the use of an approved adhesive agent at the Contractor's expense

Murram Roads

- H. Murram roads shall be laid in layers not exceeding 150mm compacted thickness, to finish compacted to the thicknesses shown on the drawings.
- J. Each layer shall be watered, rolled and compacted as previously described herein to produce a smooth dense surface free of all irregularities.

Laying Precast Paving Slabs

- A. Precast paving slabs shall be bedded on a sandbed compacted to the thickness specified with 6mm wide joints, filled and pointed with cement mortar coloured to match the colour of the slabs and recessed 5mm deep. The paving shall be finished true and even to the falls shown on the drawings with no surface irregularities.

Grassing

- B. Grassing shall be carried out by a Specialist using approved local grass. Prices for grass shall include for tending, watering, cutting and keeping weed free for a period of twelve months, to produce a dense and healthy weed free grass carpet.

Note:

The Contractor shall include here for any cost they may consider necessary and over and above costs which they believe they cannot recover in any other section of these Bills of Quantities.

COLLECTION

PREAMBLES

- Page No.2/1
- Page No.2/2
- Page No.2/3
- Page No.2/4
- Page No.2/5
- Page No.2/6
- Page No.2/7
- Page No.2/8
- Page No.2/9
- Page No.2/10
- Page No.2/11
- Page No.2/12
- Page No.2/13
- Page No.2/14
- Page No.2/15
- Page No.2/16
- Page No.2/17
- Page No.2/18
- Page No.2/19
- Page No.2/20
- Page No.2/21
- Page No.2/22
- Page No.2/23
- Page No.2/24
- Page No.2/25
- Page No.2/26
- Page No.2/27

To Collection _____

COLLECTION

- Page No.2/28
- Page No.2/29
- Page No.2/30
- Page No.2/31
- Page No.2/32
- Page No.2/33
- Page No.2/34
- Page No.2/35
- Page No.2/36
- Page No.2/37
- Page No.2/38
- Page No.2/39
- Page No.2/40
- Page No.2/41
- Page No.2/42
- Page No.2/43
- Page No.2/44
- Page No.2/45
- Page No.2/46
- Page No.2/47
- Page No.2/48
- Page No.2/49
- Page No.2/50
- Page No.2/51
- Page No.2/52
- Page No.2/53
- Page No.2/54
- Page No.2/55
- Page No.2/56
- Page No.2/57
- Page No.2/58
- Page No.2/59

**BILL 2 - PREAMBLES
CARRIED TO GENERAL SUMMARY**



BUILDER'S WORK HOSTEL BLOCK

ITEM	DESCRIPTION	UNIT	QTY	RATE	AMOUNT
	BILL NO.1 - HOSTEL BLOCK (G+9)				
	ELEMENT NO 1 - SUBSTRUCTURES (ALL PROVISIONAL)				
	Site Clearance				
A	Clear site of all grass, hedges, shrubs, bushes including grubbing up of roots, cart away arising debris and burn them.	SM	1326		
	Excavations				
B	Excavate for vegetable soil average 200 mm deep: and set aside for later reuse in landscaping	SM	1326		
C	Excavate mechanically for raft foundation,depth not exceeding 1.5 metres commencing from stripped level.	CM	1989		
D	Ditto exceeding 1.5m deep but not exceeding 3.0 metres	CM	1989		
E	Extra over excavation for excavating in soft rock	CM	1326		
	Disposal of water				
F	Allow an item for keeping all excavations free from all spring and running water by pumping or any other such means.	Item	1		
	Planking and strutting				
G	Allow an item for maintaining and upholding the sides of excavations and keeping excavations clear of all fallen materials.	Item	1		
	Carried to collection				

ITEM	DESCRIPTION	UNIT	QTY	RATE	AMOUNT
	Disposal of excavated materials				
A	Load,wheel and cart away surplus excavated material away from site	CM	3978		
	Fillings				
B	Make up levels with approved imported materials: compacted mechanically in layers not exceeding 300mm thick to the entire satisfaction of the Structural Engineer.	CM	1989		
C	300mm thick hardcore filling,hand packed and compacted in layers not exceeding 150mm thick to the entire satisfaction of the Structural Engineer;with 50mm Thick murrum blinding or "equal and approved" on top surface (measured separately)	SM	1326		
D	50 mm Thick Murrum Blinding to surfaces of hadcore	SM	1326		
	Anti - termite to treatment				
E	Approved anti-termite chemical treatment with 10 years guarantee,sprayed to the surfaces of hardcore in strict adhearence to manufacture's instruction.	SM	1326		
	Damp-proof membrane				
F	1000 gauge polythene or other equal and approved damp-proof membrane, laid over blinded hardcore (measured separately) with 300mm side and end laps (measured nett-allow for laps)	SM	1326		
	Insitu class 15 / 20 mm aggregates as described in:				
G	50 mm Thick under raft foundation	SM	1326		
	Insitu concrete class 25 (20mm maximum aggregate size);vibrated and reinforced:				
H	Raft foundation	CM	2285		
I	Columns	CM	27		
J	200mm thick lift shaft wall	SM	36		
K	200mm thick reinforced concrete retaining wall	SM	146		
L	100mm thick surface bed	SM	1326		
	Carried to collection				

ITEM	DESCRIPTION	UNIT	QTY	RATE	AMOUNT
	Ribbed reinforcement bars to BS 4449:2005 , Grade 500 high tensile strength, Including all necessary bends, hooks, tying wires and distance blocks (Provisional):				
A	Assorted reinforcement	Kg	65631		
	Mesh fabric reinforcement to BS 4483 BRC A142; 200 x 200mm, weighing 2.22kg/m² (measured net - no allowance for laps; in two layers - top & bottom; including bends, tying wire and spacer blocks				
B	In ground slab	SM	1326		
	Modular steel frame with 5mm thick steel plates covering formwork and/or marine board formwork: to:				
C	Sides of raft Foundations	SM	1470		
D	Vertical sides of columns	SM	332		
E	Ditto lift shaft wall	SM	72		
F	Ditto lift reinforced concrete retaining wall	SM	292		
G	Edge of groundslab : exceeding 75mm but not exceeding 150mm	LM	244		
	<u>Plinth</u>				
	25mm Thick cement and sand (1:4) render on concrete or masonry ; wood float finished; to				
H	Plinths; externally.	SM	147		
	Two coats black bituminous paint on:				
I	Rendered surfaces	SM	147		
	<u>Pavings in the Void</u>				
J	Supply and lay 600 x 600mm medium duty paving blocks round the Building including laying, spreading and compacting 100mm thick approved sand bed blinding to approval.	SM	353		
	Carried to collection				

ITEM	DESCRIPTION	UNIT	QTY	RATE	AMOUNT
BILL NO.1 - HOSTEL BLOCK (G+9)					
ELEMENT NO 2 - R.C FRAME					
Insitu concrete class 25 (20mm maximum aggregate size):vibrated and reinforced:					
A	Columns	CM	473		
B	200mm thick Lift shaft wall	SM	506		
C	Beams	CM	835		
D	150mm thick suspended slabs	SM	11016		
E	150mm thick Roof Slab	SM	1326		
F	150 mm thick landing	SM	120		
G	Staircases	CM	128		
Ribbed reinforcement bars to BS 4449:2005 , Grade 500 high tensile strength, including all necessary bends, hooks, tying wires and distance blocks (Provisional):					
H	Assorted reinforcement bars	KG	410324		
Modular steel frame with 5mm thick steel plates covering formwork and/or marine board formwork: to:					
I	Vertical sides of columns	SM	5989		
J	Vertical sides of lift shaft wall	SM	1012		
K	Sides and soffites of beams	SM	8264		
L	Soffits of suspended floor slabs	SM	11016		
M	Ditto suspended roof slabs	SM	1326		
N	Ditto landings	SM	120		
O	To sloping soffites of staircases	SM	468		
P	Edges of suspended slabs over 150mm but not exceeding 225mm girth	LM	2758		
Q	Ditto roof slab	LM	306		
R	Ditto landing	LM	416		
S	Ditto risers of steps	LM	1144		
T	Ditto strings cut to profile of steps,extreme girth not exceeding 300mm .	LM	240		
	ELEMENT NO. 2	Carried to			
	R.C FRAME	Main summary			

ITEM	DESCRIPTION	UNIT	QTY	RATE	AMOUNT
	BILL NO.1 - HOSTEL BLOCK (G+9)				
	ELEMENT NO 3-WALLING				
	<u>WALLING</u>				
	EXTERNAL WALLS				
	Machine cut natural quarry stone walling with minimum compressive strength to B.S 5390; bedded and jointed in cement and sand (1:4) mortar;and reinforced with and including 25mm wide x 3mm hoop iron at every alternate course as described in;				
A	200mm thick walls	SM	7353		
B	200mm thick parapet wall	SM	676		
	INTERNAL WALLS				
	Machine cut natural quarry stone walling with minimum compressive strength to B.S 5390; bedded and jointed in cement and sand (1:4) mortar;and reinforced with and including 25mm wide x 3mm hoop iron at every alternate course as described in;				
C	200mm thick walls	SM	8440		
D	100mm thick : ditto	SM	1998		
E	200mm Wide damp proof course to B.S 743 Type A bitumen hessian based 150 mm laps (no allowance made for laps); horizontal, 1 No. layer, bedded in and including cement and sand (1:3) mortar	LM	887		
	COPING				
F	300 x 100mm concrete coping to walls;twice weathered and throated;fair finished to all exposed faces	LM	355		
	CONCRETE VENT BLOCKS				
G	100mm thick concrete vent blocks bedded and jointed in cement and sand (1:4) mortar	SM	451		
	<u>ELEMENT NO. 3</u>				
	<u>WALLING</u>				
	Carried to Main summary				

ITEM	DESCRIPTION	UNIT	QTY	RATE	AMOUNT
	BILL NO.1 - HOSTEL BLOCK (G+9)				
	ELEMENT NO 4-WINDOWS				
	<u>METAL WORK</u>				
	<u>PURPOSE - MADE UNITS</u>				
	<u>PURPOSE - MADE UNITS</u>				
	<u>Supply, fabricate and fix the following purpose made small pane mild steel casement windows comprising 25 x25 x 3 mm mild steel sections for frame with tee sections as mullions including a permanent vent consisting of T bar, gauze and 16 gauge sheeet metal hood, 50 x50 mm high projections full width of the window, all members welded ground and sanded to a smooth surfaces:lugged and fixed to jambs,heads and sill with screws, and all necessary iron mongery viz hinges, fasteners, and hasp including shop priming window with red oxide primer before delivery to site:-</u>				
A	Window, overall size 2400 X 1500mm high (W 04)	NO	20		
B	Ditto size 2400 X 600mm (W 02)	NO	140		
C	Ditto Size 1200 x 1500mm high (W 01)	NO	480		
D	Ditto Size 1200 x 1200mm high (W 05)	NO	20		
E	Ditto Size 600 x 600mm high (W 03)	NO	160		
	Mild steel lourve				
F	Mild steel lourve comprising of 40x40x3mm section for frames and 25x25x3 stiles welded fixed to masonry walling	SM	176		
	<u>Glazing</u>				
G	4mm Thick clear sheet glass panes over 0.1 but not exceeding 0.5 square meters; fixing with metal putty to metal casements.	SM	1166		
H	Ditto; obscure	SM	58		
	<u>Painting and Decorations</u>				
	<u>Prepare surfaces and apply two coats of first grade quality of gloss oil paint as manufactured by Crown Solo Paints or equal and approved on;</u>				
I	General window and grille surfaces; internally and externally	SM	2998		
	Carried to Collection				

ITEM	DESCRIPTION	UNIT	QTY	RATE	AMOUNT
A	150 x 25mm thick clay window sill	LM	1080		
<u>Curtain rods:</u>					
B	20mm diameter heavy duty twin brass rod complete accessories to approval	LM	774		
Carried to collection					
COLLECTION					
Total brought forward from page no:				B/7	
Total brought forward from Above				B/8	
<u>ELEMENT NO. 4</u> <u>WINDOWS</u>		Carried to the Main summary			

ITEM	DESCRIPTION	UNIT	QTY	RATE	AMOUNT
	<p>BILL NO.1 - HOSTEL BLOCK (G+9)</p> <p>ELEMENT NO 5-DOORS</p> <p>External Doors</p> <p>Glazed mild steel casement doors</p> <p>Purpose made mild steel door comprising of 25 x 25 x3mm stiles tees to support the glass all in 40 x 40 x 2mm main frame all round , and including 50 x 50 x 3mm RHS fish tailed lugged to the wall on top and on the sides,including 4 mm clear glass fixed on to the metal tees with metal putty, all primed with one coat red oxide rime and spray painted with 2 coats of first quality gloss oil paint; complete with 180 degrees steel hinges, 2 lever mortice lock , keyed entry handle and stainless steel door sign with door number ,and all necessary seremetals assembled and fixed to opening including cutting and pinning lugs to concrete or block work surround and bedding frame in cement and sand mortar (1:3).</p>				
A	Double leaf door (D1) overall size 1800 x 2400 mm high, comprising of 2 No 800 X 2100 mm high opennable leaves and 1800 x 300 mm high fixed fanligh in 4 mm clear glass.	NO	6		
B	Single leaf door (D9) overall size 1000 x 2400 mm high, comprising of 1 No 900 X 2100 mm high opennable leaves and 900 x 300 mm high fixed fanligh in 4 mm clear glass.	NO	2		
	<p>Flush timber doors</p> <p>50mm thick semi solid cored flush door Ply wood facing finished for painting (m/s) both sides; with 15 mm thick wood liping on edges:all to Architects specifications and approval</p>				
C	Double leaf door overall size 1500mm x 2400mm high (D.08) comprising of 2No Opennable leaf size 700 x 2100mm high including fixed fanlight size 1400 x 300mm high in 4mm clear glass (measured separetely)	NO	18		
D	Single leaf door overall size 1100mm x 2400mm high (D.03) comprising of 1 No Opennable leaf size 1000 x 2100mm high including fixed fanlight size 1000 x 300mm high in 4mm clear glass (measured separetely)	NO	80		
E	Ditto 1100 x 1850 mm high (D.04) comprising of 1No. Opennable leaf size 1000 x 1850mm high	NO	70		
F	Ditto overall size 1000mm x 2400mm high (D.02) comprising of 1 No Opennable leaf size 900 x 2100mm high including fixed fanlight size 900 x 300mm high in 4mm clear glass (measured separetely)	NO	320		
G	Double leaf door overall size 900 x 2100mm high (D.06) comprising of 2No. Opennable leaf size 450 x 2050mm high	NO	126		
	Carried to collection				

ITEM	DESCRIPTION	UNIT	QTY	RATE	AMOUNT
	Internal Doors Continued				
	Flush timber doors				
	50mm thick semi solid cored flush door Ply wood facing finished for painting (m/s) both sides; with 15 mm thick wood lipping on edges:all to Architects specifications and approval				
A	Single leaf door overall size 800mm x 2400mm high (D.07) comprising of 1 No Opennable leaf size 700 x 2100mm high including fixed fanlight size 700 x 300mm high in 4mm clear glass (measured separately)	NO	120		
B	Ditto 800 x 1850mm high (D.05) comprising of 1No. Opennable leaf size 700 x 1850mm high	NO	240		
	Frames and frame finishes in wrot softwood				
C	25 x 25mm quadrant	LM	5738		
D	25 x 50mm architrave with two labours, plugged	LM	5738		
E	50 x 150mm frame with three labours; chamfered edges; plugged	LM	5738		
F	10 x 20 mm Glazing beads	LM	2,769		
	<u>Glazing</u>				
	4mm Thick clear sheet glass fixing with timber glazing beads to timber casements.				
G	In panes exceeding 0.1 sqm but not exceeding 0.5 square metres. <u>Painting and decorating</u>	SM	159		
	<u>Prepare surfaces and apply one coat of first grade quality aluminium wood primer to:-</u>				
H	Surfaces not exceeding 100mm girth	LM	14245		
I	Surfaces over 100mm but not exceeding 200mm girth	LM	5738		
	<u>Prepare surfaces and apply one undercoat and one coat first grade quality ity gloss oil paint from Crown Solo Paints or equal and approved on;</u>				
J	General timber surfaces	SM	4059		
K	Surfaces not exceeding 100mm girth	LM	14245		
L	Surfaces over 100 mm girt but not exceeding 200mm girth	LM	5738		
	Carried to collection				

ITEM	DESCRIPTION	UNIT	QTY	RATE	AMOUNT
	Doors Continued				
	Ironmongery				
	<i>Supply and Fix the following stainless steel ironmongery, complete with matching screws and keys to the approval of the Architect</i>				
A	100mm pressed steel Butt Hinges	Pairs	1677		
B	2 Lever Door mortice Lock complete with handles	NO	974		
C	Stainless steel door sign with door numbers as per Architect detail	NO	974		
	Carried to Collection				
	COLLECTION				
	Total brought forward from page no:		B/9		
	Total brought forward from page no:		B/10		
	Total brought forward from Above		B/11		
	ELEMENT NO. 5	Carried to			
	DOORS	Main summary			

ITEM	DESCRIPTION	UNIT	QTY	RATE	AMOUNT
	BILL NO.1 - HOSTEL BLOCK (G+9)				
	ELEMENT NO 6 - EXTERNAL FINISHES				
	EXTERNAL WALL FINISHES				
	External Render				
	<u>Cement and sand (1:3) render, finished with woodfloat to:-</u>				
A	15mm thick to receive paint - Beam, Columns, Slab Moulds and walling externally	SM	9273		
	External Painting				
	<u>Prepare and apply one coat undercoat and one finishing coats permaplast long lasting exterior/ weatherguard as manufactured by Crown Solo Paints or equal and approved to</u>				
B	Concrete/masonry surfaces externally-Beam, Column and Slab Moulds	SM	9273		
	ROOF FLOOR FINISHES				
	<u>Lightweight water proofed screeds</u>				
C	55mm (average) thick cement and sand vermiculite (1:6) lightweight waterproofed screed finished to falls and cross falls	SM	1326		
	<u>APP/EPDM membrane with surface finish weighing 4kg/sm; laid on primer with torch-on process from an approved manufacturer; finish to horizontsl roof slab and walls executed by a specialist under 10 years guarantee</u>				
D	4mm thick APP membrane applied to roof slabs	SM	1326		
E	Ditto to skirting 200mm high	LM	322		
F	Dress membrane around 100mm rainwater outlet	NO	6		
	<u>The Following Flat roof concrete tiles fixed with approved adhesive, laid and jointed with waterproofing bituminous compound</u>				
G	20mm thick interlocking Concrete tiles of size 225 x 225mm	SM	1326		
	Fulbora				
H	Heavy duty 150mm fullbora outlet vertical discharge including Air baffle with integrated leaf guard (UV-stabilized) with Connection to UPVC	NO.	8		
I	Supply, deliver and install 150mm thick UPVC rainwater pipes and including all the necessary pipework	LM	252		
	ELEMENT NO. 6				
	EXTERNAL FINISHES				
	Carried to Main summary				

ITEM	DESCRIPTION	UNIT	QTY	RATE	AMOUNT
	BILL NO.1 - HOSTEL BLOCK (G+9)				
	ELEMENT NO 7 - INTERNAL FINISHES				
	<u>Internal Wall Finishes</u>				
	<u>Internal Wall Finishes</u>				
	<u>12 mm thick Cement and sand (1:4) backings on blockwork to receive ceramic wall tiles:to:</u>				
A	Internal wall surfaces- Wet areas	SM	6721		
	<u>Ceramic wall tiles</u>				
	<u>Allow a prime cost supply rate of ksh 1000 per m2</u>				
B	Supply and Fix 200x200x6mm thick ceramic wall tiles as manufactured by Saj Ceramics or equal and approved on prepared backings(m.s) with proprietary adhesive; jointed and pointed in matching coloured proprietary grouting; including pvc spacers and expansion joint as necessary: all to Architect's approval. - Wall Surfaces	SM	6721		
	<u>12mm (minimum) two coat lime plaster complete with wire gauze anti-crack mechanism at the intersection of masonry walling and concrete beams as described to:-</u>				
C	Concrete/masonry surfaces Internally	SM	29013		
D	Ditto to window cills, door Jambs internally and externally; Surfaces not exceeding 200mm girth	LM	4068		
	<u>Painting and Decoration</u>				
	Prepare and apply one undercoat and one finishing coat first quality permaplat emulsion paint as manufactured by Crown Solo paints or equal and approved on:-				
E	Plastered concrete/masonry surface	SM	29013		
F	Ditto to window cills, door Jambs Externally and Surfaces not exceeding 200mm girth	LM	9806		
	Carried to Collection				

ITEM	DESCRIPTION	UNIT	QTY	RATE	AMOUNT
	<u>Floor Finishes</u>				
	<u>32 mm thick Cement and sand (1:3) backing on concrete surfaces,prepared to receive ceramic floor tiles to:</u>				
A	Floor surfaces	SM	4820		
	<u>Ceramic Floor tiles</u>				
	<u>Supply and Fix 300 x 300x 8mm thick Ceramic tiles or equal and approved; by Saj ceramic floor tiles or equal and approved; bedded and jointed in matching coloured proprietary grout on prepared on prepared backings(m.s); jointed and pointed in matching coloured proprietary grouting; including pvc spacers and expansion joint as necessary; all to Architect's approval. -Floor Surfaces</u>				
B	Ditto Non Slip Ceramic Tiles	SM	4820		
C	Ditto 100mm high skirting	LM	8114		
	<u>Cement and sand (1:4) backings as described in;</u>				
D	25mm thick finished to receive terrazzo	SM	7522		
	<u>15mm thick Colored terrazzo paving to architects specification on cement sand screed mix 1:4 (m.s),polished to smooth surface and including adhesives, hardener, mixer, and dividing strips on:-</u>				
E	Floor surfaces (Corridors, wash areas and lobby)	SM	7522		
F	Ditto 100mm high skirtings	LM	8555		
	Staircase Finishes				
	<u>25 mm thick Cement and sand (1:4) backings on concrete surfaces prepared to receive terrazo finish : to;</u>				
G	Landings	SM	130		
H	300 mm wide treads to receive terrazzo (m.s)	LM	1140		
I	150mm risers to receive terrazzo (m.s)	LM	1140		
	<u>15mm thick Colored terrazzo paving to architects specification ,polished to smooth surface and including adhesives, hardener, mixer, and dividing strips on prepared cement sand backin: to:-</u>				
J	Landings	SM	130		
K	300mm wide treads	LM	1140		
L	150 mm high risers	LM	1140		
	Carried to Collection				

ITEM	DESCRIPTION	UNIT	QTY	RATE	AMOUNT
	Staircase finishes continued				
	<u>12mm (minimum) two coat lime plaster complete with wire gauze anti-crack mechanism at the intersection of masonry walling and concrete beams as described to:-</u>				
A	Soffits of staircase landing	SM	130		
B	Ditto to sloping soffites exceeding 15° from horizontal	SM	468		
C	Staircase string 300mm extreme girth and cut to profile of steps	LM	240		
	<u>Painting and Decoration</u>				
	<u>Prepare and apply one undercoat and one finishing coat first quality plastic emulsion paint on:-</u>				
D	Soffits of staircase landing	SM	130		
E	Ditto to sloping soffites exceeding 15° from horizontal	SM	468		
F	Staircase string 300mm extreme girth and cut to profile of steps	LM	240		
	Ceiling finishes				
	<u>12mm (minimum) two coat lime plaster complete with wire gauze anti-crack mechanism at the intersection of masonry walling and concrete beams as described to:-</u>				
G	Soffites of Concrete surfaces	SM	10353		
	<u>Painting and Decoration</u>				
	<u>Prepare and apply one undercoat and one finishing coat first quality plastic emulsion paint on plastered surfaces: to:</u>				
H	Soffites of Concrete surfaces	SM	10353		
	Carried to Collection				

ITEM	DESCRIPTION	UNIT	QTY	RATE	AMOUNT
	COLLECTION				
	Total brought forward from page no:		B/12		
	Total brought forward from page no:		B/13		
	Total brought forward from page no:		B/14		
	<u>ELEMENT NO. 7</u> Carried to				
	INTERNAL FINISHES				

ITEM	DESCRIPTION	UNIT	QTY	RATE	AMOUNT
	BILL NO.1 - HOSTEL BLOCK (G+9)				
	ELEMENT NO 8- BALUSTRADING AND RAILING				
	<u>Balustrades and staircase railings</u>				
A	1000mm high mild steel balustrade; comprising 60 x 10mm mild steel standards at 900mm centres; bolted to base plate and tread (m.s), 75mm diameter mild Steel handrail part welded onto 60 x 10mm balusters; with 7No. 25mm diameter horizontal bars to Architects drawings	LM	282		
	<u>Prepare surfaces and apply two coats of first grade quality of gloss oil painton;</u>				
B	General metal surfaces of ballustrading (both sides measured overall)	SM	564		
	Hanging lines				
C	Supply,assemble anf fix, drying line consisting of 2 No 50 x 2mm,1800mm high circular hollow section post bolted on to the ground slab with 900 mm long 50 x 2mm CHS section welded at the top to form a T with and including 5 NO hooks welded to receive 5 No 3000 mm long pvc wires	NO	48		
	<u>ELEMENT NO. 8</u> Carried to the				
	<u>BALUSTRADE AND RAILING</u> Main summary				

ITEM	DESCRIPTION	UNIT	QTY	RATE	AMOUNT
	<p>BILL NO.1 - HOSTEL BLOCK (G+9)</p> <p>ELEMENT NO 9 - FITTINGS AND FIXTURES</p> <p>Allow for providing materials, labour and constructing fixtures and fittings as per Architects drawings of the following JOINERY FITTINGS AND FIXTURES complete with associated iron mongery;</p> <p>NOTE: All blockboard, MDF boards,etc in joinery works shall be lipped with hardwood beading all round before fixing.</p> <p><u>High level storage cupboard units 750mm high x 300mm wide</u></p>				
A	Ditto 1000 mm long (Studio)	LM	120		
	<p><u>Low level kitchen cupboards complete with and including concrete worktop total girth grouped together 850mm high x 600mm wide, with and including 18mm thick polished granite worktops finish</u></p>				
B	Ditto 1000mm long (Studio)	LM	120		
C	25mm thick MDF Worktop fixed on wall at 900mm FFL	SM	410		
	Carried to Collection				

ITEM	DESCRIPTION	UNIT	QTY	RATE	AMOUNT
	<p><u>WARDROBES</u></p> <p><u>Wardrobes size 2700mm high x 600mm wide in rooms</u></p> <p>A In built wardrobes</p> <p><u>32mm diameter steel pipe bolted to masonry walls with and including 2No. 10mm dia. Rawl bolts on 2 ends to bedroom in Hostel rooms</u></p> <p>B Ditto 1000mm long</p>	LM	432		
	Carried to Collection				

ITEM	DESCRIPTION	UNIT	QTY	RATE	AMOUNT
	COLLECTION				
	Total brought forward from page no:		B/17		
	Total brought forward from page no:		B/18		
	<u>ELEMENT NO. 9</u> JOINERY & FITTINGS				
	Carried to the Main summary				

ITEM	DESCRIPTION	UNIT	QTY	RATE	AMOUNT
	BILL NO.1 - HOSTEL BLOCK (G+9)				
	BUILDERS WORKS SUMMARY				
1	Substructures				
2	Reinforced Concrete Frame				
3	Walling				
4	Windows				
5	Doors				
6	External Finishes				
7	Internal Finishes				
8	Balustrade and Railing				
9	Joinery Fittings				
	<u>TOTAL FOR 1NO. BLOCK</u>				
	NO. OF BLOCKS	2			
	MULTIPLY BY 2. NO OF BLOCKS	X 2			
	<u>TOTAL FOR 2 NO. BLOCKS CARRIED TO BUILDERS WORKS SUMMARY</u>				

ELECTRICAL WORKS

SECTION 1: ELECTRICAL INSTALLATION WORKS

BILL NO:1 PRELIMINARIES & GENERAL

ITEM	DESCRIPTION	UNIT	QTY	RATE INCL. VAT KSHS.	AMOUNT INCL. VAT KSHS.
1.01	Allow for insurance of the works in accordance with the Conditions of the Contract	Item	1		
1.02	Allow for the cost of Performance Bond in accordance with the Conditions of the Contract	Item	1		
1.03	Allow for testing, commissioning and demonstration of entire installation on completion of works using the following tests: (a) Continuity Tests on all conductors (b) Ring Continuity Tests (c) Insulation Tests (d) Polarity Tests (e) Earth Fault loop Impedance (ELI) Tests (f) Prospective Fault Current Tests (g) RCD Tets (if used) (h) Verification of Voltatation drop	Item	1		
1.05	Allow for preparing and providing 3 copies of A1 & A3 Working Drawings and As Built drawings and 3 copies of record drawings instruction charts, maintenance manuals,etc all as instructed in the tender specification	Item	1		
1.07	Allow for marking on site the proposed location of service outlets for approval.	Item	1		
1.08	Allow for complete remeasure of all quantities on the practical completion of the works	Item	1		
1.09	Allow for attendance to specialist contractors i.e ICT/Fire Alarm /AVR/Generator/LV Board/CCTV/Electric Fence/Lift	Item	1		
1.10	Allow for liaison with Kenya Power & Lighting Co. Ltd.	Item	1		
Total Carried to Electrical Installation Summary Page					

Item	DESCRIPTION	UNIT	QTY	Rate (KES)	Amount (KES)
2.00	<u>BILL NO.2. TYPICAL STUDIO</u> <u>LIGHTING POINTS, FITTINGS & ACCESSORIES</u> <u>Supply, Install, Connect, Test and Set to work the following:-</u>				
2.01	Lighting points wired in 3x1.5mm ² PVC insulated single core (SC) copper cables drawn in 20mm diameter HG PVC conduit concealed in walls and or floor slabs with all accessories but excluding switch and fitting for one way switching.	No.	3		
2.02	<u>Supply, Install, Connect, Test and Set to work the following as marked on drawings and described in the schedule of Fittings:-</u> 10A 1 gang 1 way switch	No.	2		
2.03	Type C - E27 Ceiling rose c/w 10W LED Bulb	No.	1		
2.04	Type B -bathroom Globe Light	No.	1		
2.05	Type RL -7W 1 FT Reading Light	No.	1		
	<u>POWER POINTS & WIRING ACCESSORIES</u> <u>Supply, Install, Connect, Test and Set to work the following:-</u>				
2.06	Power outlet points wired as for a ring main circuit in 3 x 2.5mm ² PVC single core (SC) copper cables drawn in 25mm diameter HG PVC conduits concealed in walls and floor slabs complete with all accessories excluding the socket outlet plate.	No.	2		
2.07	Power outlet points wired as for a radial circuit in 3x4.0mm ² PVC single core (SC) copper cables drawn in 25mm diameter HG PVC conduits concealed in walls and floor slabs for instant shower but excluding the DP switch.	No.	1		
2.08	<u>Supply, Install, Connect, Test and Set to work the following as marked on drawings and described in the schedule of Fittings:-</u> 13A flush mounted twin socket-outlet	No.	2		
2.09	32A flush mounted switched DP switch	No.	1		
Total Amount for Typical Studio Unit Incl. VAT					

Item	DESCRIPTION	UNIT	QTY	Rate (KES)	Amount (KES)
3.00	<u>BILL NO.3. TYPICAL QUAD UNIT</u> <u>LIGHTING POINTS, FITTINGS & ACCESSORIES</u> <u>Supply, Install, Connect, Test and Set to work the following:-</u>				

3.01	Lighting points wired in 3x1.5mm ² PVC insulated single core (SC) copper cables drawn in 20mm diameter HG PVC conduit concealed in walls and or floor slabs with all accessories but excluding switch and fitting for one way switching.	No.	3		
<u>Supply, Install, Connect, Test and Set to work the following as marked on drawings and described in the schedule of Fittings:-</u>					
3.02	10A 1 gang 1 way switch	No.	1		
<u>Supply, Install, Connect, Test and Set to work the following as marked on drawings and described in the schedule of Fittings:-</u>					
3.03	Type C - E27 Ceiling rose c/w 10W LED Bulb	No.	1		
3.04	Type RL -7W 1 FT Reading Light	No.	2		
<u>POWER POINTS & WIRING ACCESSORIES</u>					
<u>Supply, Install, Connect, Test and Set to work the following:-</u>					
3.05	Power outlet points wired as for a ring main circuit in 3 x 2.5mm ² PVC single core (SC) copper cables drawn in 25mm diameter HG PVC conduits concealed in walls and floor slabs complete with all accessories excluding the socket outlet plate.	No.	4		
<u>Supply, Install, Connect, Test and Set to work the following as marked on drawings and described in the schedule of Fittings:-</u>					
3.06	13A flush mounted Single socket-outlet	No.	2		
3.07	13A flush mounted twin socket-outlet	No.	4		
Total Amount for Typical Quad Unit Incl. VAT					

Item	DESCRIPTION	UNIT	QTY	Rate (KES)	Amount (KES)
4.00	<u>BILL NO.4. TYPICAL SINGLE UNIT</u>				
<u>LIGHTING POINTS, FITTINGS & ACCESSORIES</u>					
<u>Supply, Install, Connect, Test and Set to work the following:-</u>					
4.01	Lighting points wired in 3x1.5mm ² PVC insulated single core (SC) copper cables drawn in 20mm diameter HG PVC conduit concealed in walls and or floor slabs with all accessories but excluding switch and fitting for one way switching.	No.	2		
<u>Supply, Install, Connect, Test and Set to work the following as marked on drawings and described in the schedule of Fittings:-</u>					
4.02	10A 1 gang 1 way switch	No.	1		

<u>Supply, Install, Connect, Test and Set to work the following as marked on drawings and described in the schedule of Fittings:-</u>				
4.03	Type C - E27 Ceiling rose c/w 10W LED Bulb	No.	1	
4.04	Type RL -7W 1 FT Reading Light	No.	1	
<u>POWER POINTS & WIRING ACCESSORIES</u>				
<u>Supply, Install, Connect, Test and Set to work the following:-</u>				
4.05	Power outlet points wired as for a ring main circuit in 3 x 2.5mm ² PVC single core (SC) copper cables drawn in 25mm diameter HG PVC conduits concealed in walls and floor slabs complete with all accessories excluding the socket outlet plate.	No.	2	
<u>Supply, Install, Connect, Test and Set to work the following as marked on drawings and described in the schedule of Fittings:-</u>				
4.06	13A flush mounted Single socket-outlet	No.	1	
4.07	13A flush mounted twin socket-outlet	No.	1	
Total Amount for Typical Single Unit Incl. VAT				

Item	DESCRIPTION	UNIT	QTY	Rate (KES)	Amount (KES)
5.00	BILL NO.5. GROUND FLOOR				
	<u>LIGHTING POINTS, FITTINGS & ACCESSORIES</u>				
	<u>Supply, Install, Connect, Test and Set to work the following:-</u>				
5.01	Lighting points wired in 3x1.5mm ² PVC insulated single core (SC) copper cables drawn in 20mm diameter HG PVC conduit concealed in walls and or floor slabs with all accessories but excluding switch and fitting for one way switching.	No.	62		
5.02	Ditto but for two way switching.	No.	8		
5.03	Ditto but for Emergency Switching.	No.	12		
	<u>Supply, Install, Connect, Test and Set to work the following as marked on drawings and described in the schedule of Fittings:-</u>				
	<u>10A white moulded wide rocker switch plates:-</u>				
5.04	10A 1 gang 1 way switch	No.	9		
5.05	10A 2 gang 2 way switch	No.	4		
5.06	10A 3 gang 2 way switch	No.	2		
5.07	10A Intermediate switch	No.	2		
	<u>Supply, Install, Connect, Test and Set to work the following as marked on drawings and described in the schedule of Fittings:-</u>				
	<u>Light fittings, complete with lamps of specified wattage and appropriate colour rendering:-</u>				
5.08	Type FB - IP44, 19W, 1200mm LED tube light fitting with diffuser	No.	8		
5.09	Type FBe - IP44, 19W, 1200mm LED tube light fitting with diffuser c/w emergency kit	No.	4		
5.10	Type C - E27 Ceiling rose c/w 10W LED Bulb	No.	8		
5.11	Type D - Round Light with LED lamp	No.	46		
5.12	Type De - Round Light with LED lamp c/w emergency kit	No.	8		
5.13	Type J - Lift shaft bulkhead fitting	No.	2		
5.14	Type Exit	No.	6		
5.15	Type P 1200 X 300MM 220/240V x 30 watt Warm White, 6500K Ceiling Mount. (Two LED Tubes)	No.	4		
	<u>POWER POINTS & ACCESSORIES</u>				
	<u>Supply, Install, connect and set to work the following:-</u>				
5.16	Power outlet points wired as for a ring main circuit in 3 x 2.5mm ² PVC single core (SC) copper cables drawn in 25mm diameter HG PVC conduits concealed in walls and floor slabs complete with all accessories excluding the socket outlet plate.	No.	15		
5.17	Power outlet points wired as for a radial circuit in 3x4.0mm ² PVC single core (SC) copper cables drawn in 25mm diameter HG PVC conduits concealed in walls and floor slabs for instant shower but excluding the DP switch.	No.	12		
Total Carried Forward to the Next Page					

Item	DESCRIPTION	UNIT	QTY	Rate (KES)	Amount (KES)
	<i>Balance Brought Forward from the Previous Page</i>				
	<u>POWER POINTS & ACCESSORIES</u>				
	Supply, Install, connect and set to work the following:-				
5.18	Power outlet points wired as for a radial circuit in 3x4.0mm ² PVC single core (SC) copper cables drawn in 25mm diameter HG PVC conduits concealed in walls and floor slabs for lift sump pump but excluding the DP switch.	No.	2		
	<u>Supply, Install, Connect, Test and Set to work the following as marked on drawings and described in the schedule of Fittings:-</u>				
5.19	13A flush mounted twin socket-outlet	No.	15		
5.20	20A flush mounted switched DP switch	No.	2		
5.21	32A flush mounted switched DP switch	No.	12		
	<u>ELV CABLE WAYS</u>				
	ICT Points				
5.22	Supply, install and connect data outlet point consisting of average 20 meters of 25 mm diameter concealed heavy gauge PVC conduit inclusive of conduit, couplers, draw boxes, switch boxes, draw wire and other necessary accessories but excluding face plates.	No.	16		
	CCTV Points				
5.23	Supply, install and connect CCTV outlet point consisting of average 20 meters of 25 mm diameter concealed heavy gauge PVC conduit inclusive of conduit, couplers, draw boxes, switch boxes, draw wire and other necessary accessories.	No.	26		
	Fire Alarm Points				
5.24	Outlets for fire Alarm points drawn in 25mm diameter heavy gauge PVC conduits concealed in wall and floor slabs including all conduit accessories and draw wire but excluding cabling and detectors	No.	24		
	<u>POWER DISTRIBUTION</u>				
	Supply, Install, connect and set to work the following:-				
5.25	Supply, install and connect 16 way TP/N distribution board for power supply in riser duct complete with 125 Amp integral isolator and MCBs as specified.	No.	2		
5.26	10A SP MCB	No.	25		
5.27	20A SP MCB	No.	20		
5.28	32A SP MCB	No.	40		
5.29	Blanking Plates	No.	11		
5.30	Allow for Labeling of distribution boards as per technical specifications	Item.	1		
5.31	Earthing of the Distribution Board above	Item.	1		
	Sub - Total Carried Forward to Ground Floor Collection Page				

ITEM NO.	TYPICAL GROUND FLOOR COLLECTION PAGE	AMOUNT KShs
1	Total Amount for Page 2 Brought Forward (Studios x 12)	
2	Total Amount for Page 3 Brought Forward (Quads x 16)	
3	Total Amount for Page 4 Brought Forward (Singles x 4)	
4	Total Amount for Page 6 Brought Forward (Common Areas)	
Sub-Total for Ground Floor carried to Electrical Installation Summary Page		

Item	DESCRIPTION	UNIT	QTY	Rate (KES)	Amount (KES)
6.00	BILL NO. 6 FIRST FLOOR COMMON AREAS				
	<u>LIGHTING POINTS, FITTINGS & ACCESSORIES</u>				
	<u>Supply, Install, Connect, Test and Set to work the following:-</u>				
6.01	Lighting points wired in 3x1.5mm ² PVC insulated single core (SC) copper cables drawn in 20mm diameter HG PVC conduit concealed in walls and or floor slabs with all accessories but excluding switch and fitting for one way switching.	No.	60		
6.02	Ditto but for two way switching.	No.	8		
6.03	Ditto but for Emergency Switching.	No.	12		
	<u>Supply, Install, Connect, Test and Set to work the following as marked on drawings and described in the schedule of Fittings:-</u>				
	<u>10A white moulded wide rocker switch plates:-</u>				
6.04	10A 1 gang 1 way switch	No.	9		
6.05	10A 2 gang 2 way switch	No.	4		
6.06	10A 3 gang 2 way switch	No.	2		
6.07	10A Intermediate switch	No.	2		
	<u>Supply, Install, Connect, Test and Set to work the following as marked on drawings and described in the schedule of Fittings:-</u>				
	<u>Light fittings, complete with lamps of specified wattage and appropriate colour rendering:-</u>				
6.08	Type FB - IP44, 19W, 1200mm LED tube light fitting with diffuser	No.	8		
6.09	Type FBe - IP44, 19W, 1200mm LED tube light fitting with diffuser c/w emergency kit	No.	4		
6.10	Type C - E27 Ceiling rose c/w 10W LED Bulb	No.	8		
6.11	Type D - Round Light with LED lamp	No.	43		
6.12	Type De - Round Light with LED lamp c/w emergency kit	No.	8		
6.13	Type J - Lift shaft bulkhead fitting	No.	2		
6.14	Type Exit	No.	6		
6.15	Type P 1200 X 300MM 220/240V x 30 watt Warm White, 6500K Ceiling Mount. (Two LED Tubes)	No.	6		
Total Carried Forward to the Next Page					

Item	DESCRIPTION	UNIT	QTY	Rate (KES)	Amount (KES)
	<i>Balance Brought Forward from the Previous Page</i>				
	<u>POWER POINTS & ACCESSORIES</u>				
	<u>Supply, Install, connect and set to work the following:-</u>				

6.16	Power outlet points wired as for a ring main circuit in 3 x 2.5mm ² PVC single core (SC) copper cables drawn in 25mm diameter HG PVC conduits concealed in walls and floor slabs complete with all accessories excluding the socket outlet plate.	No.	15		
6.17	Power outlet points wired as for a radial circuit in 3x4.0mm ² PVC single core (SC) copper cables drawn in 25mm diameter HG PVC conduits concealed in walls and floor slabs for instant shower but excluding the DP switch.	No.	12		
6.18	Power outlet points wired as for a radial circuit in 3x4.0mm ² PVC single core (SC) copper cables drawn in 25mm diameter HG PVC conduits concealed in walls and floor slabs for lift sump pump but excluding the DP switch.	No.	2		
<u>Supply, Install, Connect, Test and Set to work the following as marked on drawings and described in the schedule of Fittings:-</u>					
6.19	13A flush mounted twin socket-outlet	No.	15		
6.20	20A flush mounted switched DP switch	No.	2		
6.21	32A flush mounted switched DP switch	No.	12		
<u>ELV CABLE WAYS</u>					
<u>ICT Points</u>					
6.22	Supply, install and connect data outlet point consisting of average 20 meters of 25 mm diameter concealed heavy gauge PVC conduit inclusive of conduit, couplers, draw boxes, switch boxes, draw wire and other necessary accessories but excluding face plates.	No.	16		
<u>CCTV Points</u>					
6.23	Supply, install and connect CCTV outlet point consisting of average 20 meters of 25 mm diameter concealed heavy gauge PVC conduit inclusive of conduit, couplers, draw boxes, switch boxes, draw wire and other necessary accessories.	No.	16		
<u>Fire Alarm Points</u>					
6.24	Outlets for fire Alarm points drawn in 25mm diameter heavy gauge PVC conduits concealed in wall and floor slabs including all conduit accessories and draw wire but excluding cabling and detectors	No.	24		
<u>POWER DISTRIBUTION</u>					
<u>Supply, Install, connect and set to work the following:-</u>					
6.25	Supply, install and connect 16 way TP/N distribution board for power supply in riser duct complete with 125 Amp integral isolator and MCBs as specified.	No.	2		
6.26	10A SP MCB	No.	25		
6.27	20A SP MCB	No.	20		
6.28	32A SP MCB	No.	40		
6.29	Blanking Plates	No.	11		
6.30	Allow for Labeling of distribution boards as per technical specifications	Item.	1		
6.31	Earthing of the Distribution Board above	Item.	1		
Sub - Total Carried Forward to Ground Floor Collection Page					

ITEM NO.	TYPICAL FIRST FLOOR COLLECTION PAGE	AMOUNT KShs
1	Total Amount for Page 2 Brought Forward (Studios x 12)	
2	Total Amount for Page 3 Brought Forward (Quads x 16)	
3	Total Amount for Page 4 Brought Forward (Singles x 4)	
4	Total Amount for Page 9 Brought Forward (Common Areas)	

Sub-Total for First Floor carried to Electrical Installation Summary Page		

Item	DESCRIPTION	UNIT	QTY	Rate (KES)	Amount (KES)
7.00	BILL NO.7. TYPICAL 2ND TO 9TH FLOOR COMMON AREAS				
	<u>LIGHTING POINTS, FITTINGS & ACCESSORIES</u>				
	<u>Supply, Install, Connect, Test and Set to work the following:-</u>				
7.01	Lighting points wired in 3x1.5mm ² PVC insulated single core (SC) copper cables drawn in 20mm diameter HG PVC conduit concealed in walls and or floor slabs with all accessories but excluding switch and fitting for one way switching.	No.	59		
7.02	Ditto but for two way switching.	No.	8		
7.03	Ditto but for Emergency Switching.	No.	12		
	<u>Supply, Install, Connect, Test and Set to work the following as marked on drawings and described in the schedule of Fittings:-</u>				
	<u>10A white moulded wide rocker switch plates:-</u>				
7.04	10A 1 gang 1 way switch	No.	9		
7.05	10A 2 gang 2 way switch	No.	4		
7.06	10A 3 gang 2 way switch	No.	2		
7.07	10A Intermediate switch	No.	2		
	<u>Supply, Install, Connect, Test and Set to work the following as marked on drawings and described in the schedule of Fittings:-</u>				
	<u>Light fittings, complete with lamps of specified wattage and appropriate colour rendering:-</u>				
7.08	Type FB - IP44, 19W, 1200mm LED tube light fitting with diffuser	No.	8		
7.09	Type FBe - IP44, 19W, 1200mm LED tube light fitting with diffuser c/w emergency kit	No.	4		
7.10	Type C - E27 Ceiling rose c/w 10W LED Bulb	No.	8		
7.11	Type D - Round Light with LED lamp	No.	43		
7.12	Type De - Round Light with LED lamp c/w emergency kit	No.	8		
7.13	Type J - Lift shaft bulkhead fitting	No.	2		
7.14	Type Exit	No.	6		
7.15	Type P 1200 X 300MM 220/240V x 30 watt Warm White, 6500K Ceiling Mount. (Two LED Tubes)	No.	6		
Total Carried Forward to the Next Page					

Item	DESCRIPTION	UNIT	QTY	Rate (KES)	Amount (KES)
	<i>Balance Brought Forward from the Previous Page</i>				
	<u>POWER POINTS & ACCESSORIES</u> Supply, Install, connect and set to work the following:-				
7.16	Power outlet points wired as for a ring main circuit in 3 x 2.5mm ² PVC single core (SC) copper cables drawn in 25mm diameter HG PVC conduits concealed in walls and floor slabs complete with all accessories excluding the socket outlet plate.	No.	15		
7.17	Power outlet points wired as for a radial circuit in 3x4.0mm ² PVC single core (SC) copper cables drawn in 25mm diameter HG PVC conduits concealed in walls and floor slabs for instant shower but excluding the DP switch.	No.	12		
7.18	Power outlet points wired as for a radial circuit in 3x4.0mm ² PVC single core (SC) copper cables drawn in 25mm diameter HG PVC conduits concealed in walls and floor slabs for lift sump pump but excluding the DP switch.	No.	2		
	<u>Supply, Install, Connect, Test and Set to work the following as marked on drawings and described in the schedule of Fittings:-</u>				
7.19	13A flush mounted twin socket-outlet	No.	15		
7.20	20A flush mounted switched DP switch	No.	2		
7.21	32A flush mounted switched DP switch	No.	12		
	<u>ELV CABLE WAYS</u>				
	<u>ICT Points</u> Supply, install and connect data outlet point consisting of average 20 meters of 25 mm diameter concealed heavy gauge PVC conduit inclusive of conduit, couplers, draw boxes, switch boxes, draw wire and other necessary accessories but excluding face plates.				
7.22		No.	16		
	<u>CCTV Points</u> Supply, install and connect CCTV outlet point consisting of average 20 meters of 25 mm diameter concealed heavy gauge PVC conduit inclusive of conduit, couplers, draw boxes, switch boxes, draw wire and other necessary accessories.				
7.23		No.	16		
	<u>Fire Alarm Points</u> Outlets for fire Alarm points drawn in 25mm diameter heavy gauge PVC conduits concealed in wall and floor slabs including all conduit accessories and draw wire but excluding cabling and detectors				
7.24		No.	24		
	<u>POWER DISTRIBUTION</u> Supply, Install, connect and set to work the following:-				
7.25	Supply, install and connect 16 way TP/N distribution board for power supply in riser duct complete with 125 Amp integral isolator and MCBs as specified.	No.	2		
7.26	10A SP MCB	No.	25		
7.27	20A SP MCB	No.	20		
7.28	32A SP MCB	No.	40		
7.29	Blanking Plates	No.	11		
7.30	Allow for Labeling of distribution boards as per technical specifications	Item.	1		
7.31	Earthing of the Distribution Board above	Item.	1		
	Sub - Total Carried Forward to Ground Floor Collection Page				

ITEM NO.	TYPICAL 2ND TO 9TH FLOOR COLLECTION PAGE	AMOUNT KShs
1	Total Amount for Page 2 Brought Forward (Studios x 12)	
2	Total Amount for Page 3 Brought Forward (Quads x 16)	
3	Total Amount for Page 4 Brought Forward (Singles x 4)	
4	Total Amount for Page 12 Brought Forward (Common Areas)	
Sub-Total for 2nd-9th Floor carried to Grand Summary Page		
Multiply By 8 for the Total No. of Typical Floors		X8
Sub - Total Carried Forward to Typical 2nd - 9th Floor Collection Page		

8.00 **BILL NO.8. ROOF TERRACE**

Item	DESCRIPTION	UNIT	QTY	Rate (KES)	Amount (KES)
<u>LIGHTING POINTS, FITTINGS & ACCESSORIES</u>					
<u>Supply, Install, Connect, Test and Set to work the following:-</u>					
8.01	Lighting points wired in 3x1.5mm ² PVC insulated single core (SC) copper cables drawn in 20mm diameter HG PVC conduit concealed in walls and or floor slabs with all accessories but excluding switch and fitting for one way switching.	No.	10		
8.02	Ditto but for two way switching.	No.	8		
8.03	Ditto but for Emergency Switching.	No.	10		
<u>Supply, Install, Connect, Test and Set to work the following as marked on drawings and described in the schedule of Fittings:-</u>					
<u>10A white moulded wide rocker switch plates:-</u>					
8.04	10A 1 gang 1 way switch	No.	2		
8.05	10A 3 gang 2 way switch	No.	2		
<u>Supply, Install, Connect, Test and Set to work the following as marked on drawings and described in the schedule of Fittings:-</u>					
<u>Light fittings, complete with lamps of specified wattage and appropriate colour rendering:-</u>					
8.06	Type A4- IP65 External bulkhead fitting	No.	10		
8.07	Type A4E- IP65 External bulkhead fitting	No.	6		
8.08	Type D - Round Light with LED lamp	No.	8		
8.09	Type De - Round Light with LED lamp c/w emergency kit	No.	4		
8.10	Type J - Lift shaft bulkhead fitting	No.	2		
<u>POWER POINTS & ACCESSORIES</u>					
<u>Supply, Install, connect and set to work the following:-</u>					
8.11	Power outlet points wired as for a ring main circuit in 3 x 2.5mm ² PVC single core (SC) copper cables drawn in 25mm diameter HG PVC conduits concealed in walls and floor slabs complete with all accessories excluding the socket outlet plate.	No.	14		
8.12	Power outlet points wired as for a radial circuit in 3x4.0mm ² PVC single core (SC) copper cables drawn in 25mm diameter HG PVC conduits concealed in walls and floor slabs for Hosereel Pump but excluding the DP switch.	No.	2		
<u>Supply, Install, Connect, Test and Set to work the following as marked on drawings and described in the schedule of Fittings:-</u>					
8.13	13A flush mounted twin socket-outlet	No.	14		
8.14	20A flush mounted switched DP switch	No.	2		
Total Carried Forward to the Next Page					

Item	DESCRIPTION	UNIT	QTY	Rate (KES)	Amount (KES)
	<i>Balance Brought Forward from the Previous Page</i>				
	POWER POINTS & ACCESSORIES Supply, Install, connect and set to work the following:-				
	<u>ELV CABLE WAYS</u>				
	CCTV Points				
8.15	Supply, install and connect CCTV outlet point consisting of average 20 meters of 25 mm diameter concealed heavy gauge PVC conduit inclusive of conduit, couplers, draw boxes, switch boxes, draw wire and other necessary accessories.	No.	10		
	Fire Alarm Points				
8.16	Outlets for fire Alarm points drawn in 25mm diameter heavy gauge PVC conduits concealed in wall and floor slabs including all conduit accessories and draw wire but excluding cabling and detectors	No.	6		
	<u>POWER DISTRIBUTION</u>				
	Supply, Install, connect and set to work the following:-				
8.17	Supply, install and connect 4 way TP/N distribution board for power supply in riser duct complete with 125 Amp integral isolator and MCBs as specified.	No.	2		
8.18	10A SP MCB	No.	4		
8.19	20A SP MCB	No.	8		
8.20	32A SP MCB	No.	2		
8.21	Blanking Plates	No.	2		
8.22	Allow for Labeling of distribution boards as per technical specifications	Item.	1		
8.23	Earthing of the Distribution Board above	Item.	1		
	Sub-Total for Roof Terrace carried to Electrical Installation Summary Page				

Item	DESCRIPTION	UNIT	QTY	Rate (KES)	Amount (KES)
9.00	<u>BILL NO.9: MAIN POWER DISTRIBUTION</u>				
	<u>LV BOARDS</u>				
	<u>Supply, Deliver and Position the Following:</u>				
9.01	Free- Standing Bottom Entry, Bottom Exit Main LV Panel as IP-32, Form-3B, 700Amps 4 poles copper busbars as per the Schematic and in compliance with IEC 60439 and KSIEC 60439 Standards, complete with the following:- - Space for 1 no. KPLC Postpaid CT Meter - Space for 3 Phase KPLC Cutouts and CTs - 40kA 3P + N Type 1 and 2 Surge Protector complete with protection circuit, fault sensing and indicating mechanism INCOMER - 1 No.630A 3P Adj MCCB 36kA Incomer c/w Shunt Trip - Fireman's switch connection termination points as shown on the schematic drawing ATS - 1No. 100A 4P ATS comprising of the following:- * 2No. 100A 3P 18kA MCCBs * 2No. 100A 4P Contactors c/w mechanical and Electrical interlock * Phase Failure (Over/Under Voltage/Phase Sequence) Relay * Gen Start/Stop Signal * Battery Trickle Charger contacts - LED Indicator Lamps (MAINS AVAIL, MAINS ON LOAD, GEN AVAIL, GEN ON LOAD) ' - 2No. Class 1 CT Digital Multimeter capable of measuring the following parameters (V,I,S,Q,P,kWh,F,PF) Outgoers: - 4No. A 3P ADJ 250A MCCB for Rooms Sub -Board - 1No. A 3P ADJ 200A MCCB for PFC Bank - 2No. 63A 3P 16kA MCCB for Lifts - 1No. 63A 3P 16kA MCCB for Pump Room DB - 2No. 63A 3P 16kA MCCB for Tower Common Area DBs at the Ground Floor - 3 nos. 3P 100A Spares PFC Bank - 100kVAr PFC bank, 12 steps contoller (1.25,1.25,2.5,5,10,10,10,20,50 kVAr) complete with circuit protection and indicator	No.	1		
9.02	Label LV switchboard as per schematic drawing.	Item	1		
9.03	Provide As-Built Schematic Drawing	Item	1		
	<u>SUB-BOARDS NON-MAINTAINED POWER</u>				
9.04	6 way Sub-board in the ducts as IP-32, Form-2B as per the Schematic and in compliance with IEC 60439 and KSIEC 60439 Standards, complete with the following:- Incomer 1No. 250A TP Adj. MCCB Indicator Lamps (RYB) Outgoers - 5 nos. adj 3P 63A, 25kA, MCCBs Outgoers - 1 nos. 3P 63A Spares	No.	4		
9.05	Label Subboard as per schematic drawing.	Item	1		
9.06	Provide As-Built Schematic Drawing	Item	1		
	Total Carried Forward to the Next Page				

Item	DESCRIPTION	UNIT	QTY	Rate (KES)	Amount (KES)
	<i>Balance Brought Forward from the Previous Page</i>				
	<u>GENERATOR SPLIT BOARD</u>				
9.07	Generator Split board in the in the Generator Room as IP-32, Form-2B as per the Schematic and in compliance with IEC 60439 and KSIEC 60439 Standards, complete with the following:- Incomer 250A TP Adj. MCCB Indicator Lamps (RYB) Outgoers - 2 nos. adj 3P 100A, 25kA, MCCBs Outgoers - 1 nos. 3P 63A Spares	No.	1		
9.08	Label Subboard as per schematic drawing.	Item	1		
9.09	Provide As-Built Schematic Drawing	Item	1		
	<u>SUB-BOARDS-MAINTAINED POWER-02</u>				
9.10	6 way Sub-board in the ducts as IP-32, Form-2B as per the Schematic and in compliance with IEC 60439 and KSIEC 60439 Standards, complete with the following:- Incomer 63A TP Adj. MCCB Indicator Lamps (RYB) Outgoers - 5 nos. adj 3P 45A, 25kA, MCCBs Outgoers - 1 nos. 3P 63A Spares	No.	2		
9.11	Label Subboard as per schematic drawing.	Item	1		
9.12	Provide As-Built Schematic Drawing	Item	1		
	<u>DISTRIBUTION BOARDS</u>				
	Supply, Install, connect and set to work the following:-				
9.13	Supply, install and connect 16 way TP/N distribution board for power supply in riser duct complete with 125 Amp integral isolator and MCBs as specified.	No.	20		
9.14	10A SP MCB	No.	250		
9.15	20A SP MCB	No.	200		
9.16	32A SP MCB	No.	400		
9.17	Blanking Plates	No.	110		
9.18	Allow for Labeling of distribution boards as per technical specifications	Item.	1		
9.19	Earthing of the Distribution Boards above	Item.	1		
	<u>CABLES</u>				
9.20	Submains circuit from the Main board to Sub-Boards (SB-GF/01, SB-FF-01,SB-GF/02, SB-FF-02) in electrical ducts comprising of 70mm ² XLPE/PVC/SWA 4c + 35mm ² sc ECC Copper cables laid in PVC Duct and Trays	Lm.	200		
	Total Carried Forward to the Next Page				

Item	DESCRIPTION	UNIT	QTY	Rate (KES)	Amount (KES)
	Balance Brought Forward from the Previous Page				
9.21	Submains circuit from the Generator to the Main Board comprising of 35mm ² XLPE/PVC/SWA 4c + 16mm ² sc ECC Copper cables laid in PVC Duct and Trays	Lm.	20		
9.22	Submains circuit from the Main board to the Typical Floors DB comprising of 16mm ² XLPE/PVC/SWA 4c + 10.0mm ² sc ECC Copper cables laid in PVC Duct and Trays	Lm.	540		
9.23	Submains circuit from the Main board to the Pump Room DB comprising of 16mm ² XLPE/PVC/SWA 4c + 10.0mm ² sc ECC Copper cables laid in PVC Duct and Trays	Lm.	50		
9.21	Submains circuit from Mian LV Board to Lifts DB comprising of 10mm ² XLPE/PVC/SWA 4c + 6.0mm ² sc ECC Copper cables laid in PVC Duct and Trays	Lm.	130		
9.24	Submains circuit from Main Board to Common Area DBs at the Ground Floor Electrical Ducts comprising of 10mm ² XLPE/PVC/SWA 4c + 6.0mm ² sc ECC Copper cables laid in PVC Duct and Trays	Lm.	100		
9.25	Submains circuit from Common Area Sub-Board at the Ground Floor to, Common Area and Roof Terrace DBs comprising of 10mm ² XLPE/PVC/SWA 4c + 6.0mm ² sc ECC Copper cables laid in PVC Duct and Trays	Lm.	100		
9.26	Cable gland for above cables terminations	Lot.	1		
9.27	Cable Lugs for above cables terminations	Lot.	1		
	<u>CABLE MANAGEMENT</u>				
9.28	400 x 50mm Powder coated fabricated Cable tray complete with angle bends, Tees, end caps and mounting brackets & accessories to detail and to approval. Including equipotential bonding.	Lm.	300		
9.29	300 x 50mm Powder coated fabricated Cable tray complete with angle bends, Tees, end caps and mounting brackets & accessories to detail and to approval. Including equipotential bonding.	Lm.	200		
9.30	150 x 50mm Powder coated fabricated Cable tray complete with angle bends, Tees, end caps and mounting brackets & accessories to detail and to approval. Including equipotential bonding.	Lm.	100		
	<u>MECHANICAL LOADS</u>				
9.31	Supply, install and connect 4 way TP/N distribution board for Pump Room power supply in riser duct complete with 125 Amp integral isolator and MCBs as specified.	No.	1		
9.32	Supply, install and connect 4 way TP/N distribution board for Lifts power supply in riser duct complete with 125 Amp integral isolator and MCBs as specified.	No.	2		
9.33	63A TP Isolators for Lift	No.	2		
9.34	Supply and install 16A/ 20 Amp weather proof TP isolators for pumps and other equipment.	No.	4		
	Total Carried to Electrical Installation Summary Page				

Item	DESCRIPTION	UNIT	QTY	Rate (KES)	Amount (KES)
10.00	<u>BILL NO. 10. EXTERNAL WORKS</u>				
10.01	Allow for trenching of 750mm and width 450mm, laying of 2x 200mm Conduit, back filling of trenches, and laying of "DANGER " cable tiling (for cable running along non-concrete areas), reinstatement and making of good of ground as directed by the Engineer on site	Lm	250		
10.02	200mm Heavy Guege PVC pipes and fittings laid in trenches and complete with draw wires	Lm	500		
10.03	100mm Heavy Guege PVC pipes and fittings laid in trenches and complete with draw wires	No.	250		
10.04	Power Manholes of sizes 1000mmLx1000mmWx1000mm deep Cable pits, excavation, 100mm plain in-situ concrete class 21/20 base and sides, 100mm thick precast concrete cover class 21/20 reinforced with two layers of mesh reinforcement A142 weighing 2.2Kgs per square meter with galvanized lifting handles, holes through sides for 100mm & 200mm dia pipes for Power.	No.	13		
10.05	Data Manholes of sizes 600mmLx600mmWx600mm deep Cable pits, excavation, 100mm plain in-situ concrete class 21/20 base and sides, 100mm thick precast concrete cover class 21/20 reinforced with two layers of mesh reinforcement A142 weighing 2.2Kgs per square meter with galvanized lifting handles, holes through sides for 100mm & 200mm dia pipes for Data.	No.	13		
10.10	<u>EXTERNAL LIGHTING</u>				
	Supply, Install, Test, Commission and Set to work:-				
10.11	Lighting points wired in 3x1.5mm ² PVC insulated single core (SC) copper cables drawn in 20mm diameter HG PVC conduit concealed in walls and or floor slabs with all accessories but excluding switch and fitting for one way switching.	No.	32		
10.12	Supply and install 20A 4 poles AC3 duty contactor mounted on DIN rails in the sub-board for external lighting circuits inclusive of wiring to contactor coil.	No.	1		
10.13	Supply and install Programmable digital time switch with minimum 100 hours reserve and over-ride facility for external lighting.	No.	1		
	Supply, deliver to site and install the following complete with lamps, control gear/drivers as appropriate including fixings and supports:		1		
10.14	Type WL- IP65 External bulkhead fitting	No.	30		
10.15	Type SL-Street lights 50W c/w 6m pole, integrated, 90AH, 2V Lithium battery, solar panel, and intelligent dusk to dawn controls	No.	14		
10.16	Gate lights 50W	No.	2		
	SPECIALIZED ITEMS CABLE WAYS				
	<u>CCTV POINTS</u>				
10.17	CCTV points drawn in 25mm diameter heavy gauge PVC conduits concealed in wall and floor slabs including all conduit accessories and draw wire but excluding cabling and termination kits	No.	12		
	Total Carried to Electrical Installation Summary Page				

11.00 BILL NO.11: FIRE ALARM SYSTEM

ITEM	DESCRIPTION	UNIT	QTY	RATE	AMOUNT
11.01	Microprocessor based 2-Loop Addressable Fire Alarm Control Panel	No.	1		
11.02	Addressable Photoelectric Smoke Detector	No.	200		
11.03	Addressable Heat Detector as Menvier or Approved equivalent	No.	40		
11.04	Addressable Manual Fire Alarm 'Break Glass' call points	No.	40		
11.05	Addressable Electronic Fire Alarm sounder complete with Red Flashing beacon	No.	40		
11.06	Microprocessor based Addressable Fire Alarm Repeater Panel	No.	1		
11.07	2x2.5mm ² FP 200 Network cables for connecting the above panels.	Lm	180		
11.08	Demonstrate operation of the complete fire alarm system in presence of manufacturer's representative	Item	1		
11.09	Connect, test, program and commission the fire alarm system and provide log and schedule of active devices	Item	1		
11.10	Operation manuals and 3 sets of record drawings both hard and soft copies	Item	1		
Total Carried to Electrical Installation Summary Page					

12.00 **BILL NO.12: LIGHTNING PROTECTION**

Item	DESCRIPTION	UNIT	QTY	Rate (KES)	Amount (KES)
	Supply, Install, Test, Commission and Set to work:-				
	Air Termination				
12.01	2000mm x15mmØ multiple point pure copper AirRods/ Termination with spikes as Furse Part No. RA240 or approved equivalent	No	2		
12.02	Copper Air Rod Base as Furse Part No. SD105-H or approved equivalent	No.	2		
12.03	Copper Junction Clamps for copper tape as Furse Part No. CN105-H or approved equivalent	No.	2		
12.04	25x3mm copper tape TC030 on tape clip Furse CP210 including saddles, appropriate bonding & jointing clamps to bond and clamp the tape to masonry wall.	Lm	400		
	Down Conductor				
12.05	32mm diameter HG concealed PVC conduit with factory made bends, all conduit fittings as shown on drawing.	Lm	80		
12.06	70mm ² bare copper conductor enclosed HG concealed PVC conduit between copper tape and test joint (down conductor).	Lm	100		
12.07	Screwdown copper test clamp as Furse CT305 or approved equivalent	No.	2		
	Earth Termination				
12.08	Supply and install earthing complete with Earthing Matt measuring 1000x1000mm build in 25mm x 3mm thick riveted with copper rivets. 2Nos. Earth electrodes, and 2Nos. Rod to tape clamps. The earth matt to be treated by marconite and salt to obtain reading <10.0 ohms.	No.	2		
12.09	70mm ² ECC in 1x25mm dia PVC conduit between the test clamp and the earth rods.	Lm	10		
12.10	Concrete earthing inspection pits	No	2		
12.11	Test the completed lightning protection system and log in results	Item	1		
	Bonding				
2.13	Bonding and clamping to all metal work including water pipes, gas pipes, hand-rails, smatv system, window frames, cladding, metal roof etc. and the main earth for the building.	Item	1		
Total Carried to Electrical Installation Summary Page					

ELECTRICAL INSTALLATION WORKS SUMMARY PAGE		AMOUNT
1.00	Bill No:1 Preliminaries & General	
2.00	Bill No.2. Ground Floor Electrical Installation Works	

3.00	Bill No.3. First Floor Electrical Installation Works	
4.00	Bill No.4. Typical 2nd -9th Floor Electrical Installation Works	
5.00	Bill No.5. Roof Terrace	
6.00	Bill No.6: Main Power Distribution	
7.00	Bill No. 7. External Works	
8.00	Bill No.8: Fire Alarm System	
9.00	Bill No.9: Lightning Protection	
	Total Amount for 1 Typical Block Inclusive of VAT	
	Total for 2No. Typical Blocks	x2
TOTAL CARRIED FORWARD TO GRAND SUMMARY PAGE INCL. VAT		

Amount in Words: Kenya Shillings.....

.....

.....

Official Stamp & Address:.....

.....

Tenderer's Signature:.....Date:.....

Witness' Name:.....Witness' Signature:.....

Address:.....

Date:.....

MECHANICAL WORKS

ITEM	DESCRIPTION	UNIT	QTY	RATE	AMOUNT
A	<u>PRELIMINARY</u>				
1	Allow for insurance of the works in accordance with the Conditions of the Contract	Item	1		
2	Allow for the cost of Performance Bond in accordance with the Conditions of the Contract	Item	1		
3	Allow for testing, commissioning and demonstration of entire installation on completion of works.	Item	1		
4	Allow for preparing and providing 3 copies of A1 & A3 Working Drawings/ As Built drawings and 3 copies of record drawings instruction charts, maintenance manuals,etc all as instructed in the tender specification	Item	1		
5	Allow for marking on site the proposed location of service outlets and installation of sleeves for approval.	Item	1		
6	Allow for complete remeasure of all quantities on the practical completion of the works	Item	1		
TOTAL TO MAIN SUMMARY PAGE					

ITEM	DESCRIPTION	UNIT	QTY	RATE	AMOUNT
B	<u>SANITARYWARE SUPPLY & INSTALL ONLY</u>				
I	<u>GROUND & FIRST FLOOR</u>				
	<u>SUPPLY & INSTALL</u> Supply and deliver the following appliances including their support brackets, screws etc.				
	<u>WC suite</u>				
1	Dual flush close couple toilet suite complete with Push button dual flush system, Comes with Soft Close Seat Cover, WC Connector, fixing brackets, PEX – O14 Fanski Flexible Connector: 1/2in x 1/2in x 30cm, Angle Valve, with Extension: 1/2 x 1/2in	No.	24		
	<u>Washbasin and Tap</u>				
2	White Drop In Basin - with full pedestal -White, One central taphole fixing brackets, PVC Bottle Trap and waste 1.25in x 40, Chrome Tempo Push-Delay Action Basin Tap, PEX – O14 Fanski Flexible Connector: 1/2in x 1/2in x 30cm, Angle Valve, with Extension: 1/2 x 1/2in	No.	32		
	<u>Shower & Fittings</u>				
3	Concealed shower fittings comprising of plastic shower arm, stop cock and bib tap, Instant Shower 3kW Element, Shielded selection switch, Adjustable three temperatures, hard and salty water application	No	24		
	<u>Kitchen sink and Tap</u>				
4	Concrete Kitchen Sink, PVC Bottle Trap and waste 1.5in x 40, Long Neck Wall type Bib Tap	No.	12		
	<u>Bathroom Accessories</u>				
5	Robe Hook (Single), Chrome Plated	No.	24		
6	Vertical Soap Dispenser: Satin	No.			
7	Toilet Roll Holder	No.	24		
8	Bathroom Mirror, (80×60)cm	No.			
	<u>Fire blankets</u>				
9	Fire Blanket (1.2 x 1.2m)	No.	4		
	<u>Urinal</u>				
10	Urinal bowl white - top entry complete with zeda:bottle trap and waste 1.5in x 40, exposed (top entry) urinal flush valve 40mm, White Wall Hung Urinal Divider	No.	2		
	<u>Disabled WC Suite</u>				
11	Close Couple one piece wc, s trap, with soft close seat and twin flush fittings, and wc connector, angle valve and flex hose, crane wall hung wash basin 665 x 545 x 190mm c/w bottle trap, angle valve, flex hose, clinical single lever basin tap, 1no. wall mounted grab bar 600 mm long, 1No. wall mounted hinged hand rail 750 x 100 mm, 1no. door mounted grab bar 600 mm long	No.	4		
	<u>Common Kitchen sink and Tap</u>				
12	Concrete Kitchen Sink, PVC Bottle Trap and waste 1.5in x 40, Long Neck Wall type Bib Tap	No.	12		
	<u>Total For 1No. Floor</u>				
	<u>Total For 2No. Floor</u>				2.00
	TOTAL TO SANITARYWARE SUPPLY COLLECTION PAGE				

ITEM	DESCRIPTION	UNIT	QTY	RATE	AMOUNT
II	TYPICAL 2ND TO 9TH FLOOR				
	SUPPLY & INSTALL				
	Supply and deliver the following appliances including their support brackets, screws etc.				
	WC suite				
1	Dual flush close couple toilet suite complete with Push button dual flush system, Comes with Soft Close Seat Cover, WC Connector, fixing brackets, PEX – O14 Fanski Flexible Connector: 1/2in x 1/2in x 30cm, Angle Valve, with Extension: 1/2 x 1/2in	No.	24	-	
	Washbasin and Tap				
2	White Drop In Basin - with full pedestal -White, One central taphole fixing brackets, PVC Bottle Trap and waste 1.25in x 40, Chrome Tempo Push-Delay Action Basin Tap, PEX – O14 Fanski Flexible Connector: 1/2in x 1/2in x 30cm, Angle Valve, with Extension: 1/2 x 1/2in	No.	36	-	
	Shower & Fittings				
3	Ce concealed shower fittings comprising of plastic shower arm, stop cock and bib tap, Instant Shower 3kW Element, Shielded selection switch, Adjustable three temperatures, hard and salty water application	No	24	-	
	Kitchen sink and Tap				
4	Concrete Kitchen Sink, PVC Bottle Trap and waste 1.5in x 40, Long Neck Wall type Bib Tap	No.	12	-	
	Bathroom Accessories				
5	Robe Hook (Single), Chrome Plated	No.	24	-	
6	Vertical Soap Dispenser: Satin	No.		-	
7	Toilet Roll Holder	No.	24	-	
8	Bathroom Mirror, (80×60)cm	No.		-	
	Fire blankets				
9	Fire Blanket (1.2 x 1.2m)	No.	4	-	
	Urinal				
10	Urinal bowl white - top entry complete with zeda:bottle trap and waste 1.5in x 40, exposed (top entry) urinal flush valve 40mm, White Wall Hung Urinal Divider	No.	2	-	
	Disabled WC Suite				
11	Close Couple one piece wc, s trap, with soft close seat and twin flush fittings, and wc connector, angle valve and flex hose, crane wall hung wash basin 665 x 545 x 190mm c/w bottle trap, angle valve, flex hose, clinical single lever basin tap, 1no. wall mounted grab bar 600 mm long, 1No. wall mounted hinged hand rail 750 x 100 mm, 1no. door mounted grab bar 600 mm long	No.	4	-	
	Common Kitchen sink and Tap				
12	Concrete Kitchen Sink, PVC Bottle Trap and waste 1.5in x 40, Long Neck Wall type Bib Tap	No.	12	-	
	Total For 1No. Floor				
	Total For 8No. Floor				8.00
	TOTAL TO SANITARYWARE SUPPLY COLLECTION PAGE				

ITEM	DESCRIPTION	UNIT	QTY	RATE	AMOUNT
	SANITARY SUPPLY & INSTALL COLLECTION PAGE				
I	Ground & First Floor				
II	2nd to 9th Floor Typical				
	Sub Total For 1No. Block				
	Total For 2No. Blocks				2.00
TOTAL TO MAIN SUMMARY PAGE					

ITEM	DESCRIPTION	UNIT	QTY	RATE	AMOUNT
C	INTERNAL PLUMBING				
I	GROUND FLOOR & FIRST FLOOR				
	Supply, deliver and install PN20 PPR pipes and fittings for sizes up to 110mm for cold water. Tenderers must allow in their pipework prices for all the couplings, connectors, joints etc. required in the running length of pipework and also where necessary, for pipe fixing clips, holder bats plugged and screwed, brackets, and pipe sleeves through structural members. The solvent weld shall be by a heat gun as recommended by the manufacturer.				
	Cold Water				
1	25mm diameter PPR Pipes	LM	100		
2	32mm diameter PPR Pipes	LM	120		
3	40mm diameter PPR Pipes	LM	180		
	Extra over PPR tubing for the following:				
4	25mm diameter PPR 90° elbow	No.	60		
5	32mm diameter PPR 90° elbow	No.	48		
6	40mm diameter PPR 90° elbow	No.	39		
	Tees				
7	25mm diameter PPR equal tee	No.	24		
8	32mm diameter PPR equal tee	No.	40		
9	40mm diameter PPR equal tee	No.	80		
	Reducer Coupling				
10	25x20mm diameter PPR reducer coupling	No.	88		
11	32x25mm diameter PPR reducer coupling	No.	48		
12	40x32mm diameter PPR reducer coupling	No.	20		
	Reducer Tees				
13	25x20mm diameter PPR reducer tees	No.	16		
14	32x25mm diameter PPR reducer tees	No.	20		
15	40x32mm diameter PPR reducer tees	No.	20		
	Union				
16	25mm diameter PPR union	No.	12		
17	32mm diameter PPR union	No.	16		
18	40mm diameter PPR union	No.	20		
	Gate Valves				
19	32mm dia approved high pressure screw- down full way non-rising stem solid wedge disc gate valve to BS 5154 PN 16 for Series B Rating with wheel head and metal/plastic adaptors to PPR tubing. Valve to be as "Crane Model " or equal and approved	No.	12		
20	63mm ditto	No.	20		
	TOTAL TO NEXT PAGE				

ITEM	DESCRIPTION	UNIT	QTY	RATE	AMOUNT
	<i>Balance brought forward</i>				
	<u>PPR Male threaded adaptors (Brass threads).</u>				
21	20 x 3/4" dia Male threaded adaptors (Brass threads).	No.	56		
22	25 x 1" dia ditto	No.	28		
23	32 x 1 1/4" dia ditto	No.	12		
24	63 x 1 1/2" dia ditto	No.	20		
	<u>PPR Male/Female threaded elbows (Brass threads).</u>				
25	20 x 3/4" dia female threaded adaptors (Brass threads).	No.	56		
26	25 x 1" dia ditto	No.	28		
27	32 x 1 1/4" dia ditto	No.	12		
28	40 x 1 1/2" dia ditto	No.	20		
	<u>Check Meter</u>				
29	Allow for 63mm diameter "Kent" water check meters	No.			
	<u>Total for 1No. Floor</u>				
					2.00
	<u>Total for 2No. Floor</u>				
TOTAL TO INTERNAL PLUMBING COLLECTION PAGE					

ITEM	DESCRIPTION	UNIT	QTY	RATE	AMOUNT
II	<u>TYPICAL 2ND TO 9TH FLOOR</u>				
	Supply, deliver and install PN20 PPR pipes and fittings for sizes up to 110mm for cold water. Tenderers must allow in their pipework prices for all the couplings, connectors, joints etc. required in the running length of pipework and also where necessary, for pipe fixing clips, holder bats plugged and screwed, brackets, and pipe sleeves through structural members. The solvent weld shall be by a heat gun as recommended by the manufacturer.				
	<u>Cold Water</u>				
1	25mm diameter PPR Pipes	LM	100		
2	32mm diameter PPR Pipes	LM	120		
3	40mm diameter PPR Pipes	LM	180		
	<u>Extra over PPR tubing for the following:</u>				
4	25mm diameter PPR 90° elbow	No.	60		
5	32mm diameter PPR 90° elbow	No.	48		
6	40mm diameter PPR 90° elbow	No.	39		
	<u>Tees</u>				
7	25mm diameter PPR equal tee	No.	24		
8	32mm diameter PPR equal tee	No.	40		
9	40mm diameter PPR equal tee	No.	80		
	<u>Reducer Coupling</u>				
10	25x20mm diameter PPR reducer coupling	No.	88		
11	32x25mm diameter PPR reducer coupling	No.	48		
12	40x32mm diameter PPR reducer coupling	No.	20		
	<u>Reducer Tees</u>				
13	25x20mm diameter PPR reducer tees	No.	16		
14	32x25mm diameter PPR reducer tees	No.	20		
15	40x32mm diameter PPR reducer tees	No.	20		
	<u>Union</u>				
16	25mm diameter PPR union	No.	12		
17	32mm diameter PPR union	No.	16		
18	40mm diameter PPR union	No.	20		
	<u>Gate Valves</u>				
19	32mm dia approved high pressure screw- down full way non-rising stem solid wedge disc gate valve to BS 5154 PN 16 for Series B Rating with wheel head and metal/plastic adaptors to PPR tubing. Valve to be as "Crane Model " or equal and approved	No.	12		
20	63mm ditto	No.	20		
	TOTAL TO NEXT PAGE				

ITEM	DESCRIPTION	UNIT	QTY	RATE	AMOUNT
	<i>Balance brought forward</i>				
	<u>PPR Male threaded adaptors (Brass threads).</u>				
1	20 x 3/4"ø dia Male threaded adaptors (Brass threads).	No.	56		
2	25 x 1"ø dia ditto	No.	28		
3	32 x 1 1/4"ø dia ditto	No.	12		
4	63 x 1 1/2"ø dia ditto	No.	20		
	<u>PPR Male/Female threaded elbows (Brass threads).</u>				
5	20 x 3/4"ø dia female threaded adaptors (Brass threads).	No.	56		
6	25 x 1"ø dia ditto	No.	28		
7	32 x 1 1/4"ø dia ditto	No.	12		
8	40 x 1 1/2"ø dia ditto	No.	20		
	<u>Check Meter</u>				
9	Allow for 63mm diameter "Kent" water check meters	No.			
	<u>Total for 1No. Floor</u>				
					8.00
	<u>Total for 8No. Floor</u>				
TOTAL TO INTERNAL PLUMBING COLLECTION PAGE					

ITEM	DESCRIPTION	UNIT	QTY	RATE	AMOUNT
C	INTERNAL PLUMBING COLLECTION PAGE				
I	Ground & First Floor				
II	Typical 1st To 9 th Floor				
	Sub Total For 1No. Block				
	Total For 2No. Blocks				2.00
	TOTAL TO MAIN SUMMARY PAGE				

ITEM	DESCRIPTION	UNIT	QTY	RATE	AMOUNT
D	<u>FOUL DRAINAGE</u>				
I	<u>GROUND FLOOR</u>				
	Supply and fix uPVC soil system to BS 4660 and BS 4515 and MuPVC waste system to BS 5255 with screwed and socketed joints to BS 21. Solvent welded joints shall be as socketed joints to BS 21. Solvent welded joints shall be as per the system manufacturer's written instructions. Tenderers must allow in their pipework prices for all the couplings, connectors, joints, etc. as required in the running lengths of pipework and also where necessary for pipe fixing clips, holderbats, plugs and screwed. The installation must comply with BS 5572.				
	<u>Note: Trade Names</u> Caradon Terrain Ltd's pipe and fittings have been used as a guide to the type and quality of materials required. Other brands must be equal and approved in writing by the Engineer inconsistency shall not be accepted.				
	<u>SOIL & WASTE DRAINAGE</u>				
	<u>Above Ground</u>				
	<u>MuPVC waste System conforming to BS 5255</u>				
1	32Φ Waste pipe	LM	60		
2	40Φ Waste pipe	LM	150		
3	50Φ Waste pipe	LM	145		
4	100Φ Waste pipe	LM	300		
	Extra over MuPVC waste pipework for the following:				
5	32Φ 90 degree sweep Bend	No.	48		
6	40Φ 90 degree sweep Bend	No.	56		
7	50Φ 90 degree sweep Bend	No.	24		
8	100Φ 90 degree sweep Bend	No.	24		
9	32Φ Sweep Tee	No.			
10	40Φ Sweep Tee	No.	20		
11	50Φ Sweep Tee	No.	20		
12	100Φ Sweep Tee	No.			
13	100Φ Double Branch	No.			
14	32Φ Access plug	No.	16		
15	40Φ Access plug	No.	20		
16	50Φ Access plug	No.	4		
17	100Φ Access plug	No.			
18	32mm dia - socket	No.	12		
19	40mm dia - socket	No.	8		
20	50mm dia - socket	No.			
21	100mm dia - socket	No.			
	TOTAL TO NEXT PAGE				

ITEM	DESCRIPTION	UNIT	QTY	RATE	AMOUNT
	<i>Balance brought forward</i>				
22	50 x 32mm dia - socket reducer	No.	12		
23	50 x 40mm dia - socket reducer	No.	8		
24	100 x 50mm dia - Boss connectors	No.			
25	100 x 50 Floor traps complete with Plastic Grating	No.	32		
26	100Φ Vent Cowl	No.	28		
27	Allow for 2" PVC pipe sleeves through/ on side of the columns in bathrooms	LM	8		
Total For 1No. Floor					
TOTAL TO INTERNAL DRAINAGE COLLECTION PAGE					

ITEM	DESCRIPTION	UNIT	QTY	RATE	AMOUNT
II	<u>TYPICAL 1ST TO 9TH FLOOR</u>				
	Supply and fix uPVC soil system to BS 4660 and BS 4515 and MuPVC waste system to BS 5255 with screwed and socketed joints to BS 21. Solvent welded joints shall be as socketed joints to BS 21. Solvent welded joints shall be as per the system manufacturer's written instructions. Tenderers must allow in their pipework prices for all the couplings, connectors, joints, etc. as required in the running lengths of pipework and also where necessary for pipe fixing clips, holderbats, plugs and screwed. The installation must comply with BS 5572.				
	<u>Note: Trade Names</u> Caradon Terrain Ltd's pipe and fittings have been used as a guide to the type and quality of materials required. Other brands must be equal and approved in writing by the Engineer inconsistency shall not be accepted.				
	<u>SOIL & WASTE DRAINAGE</u>				
	<u>Above Ground</u>				
	<u>MuPVC waste System conforming to BS 5255</u>				
1	32Φ Waste pipe	LM	60		
2	40Φ Waste pipe	LM	150		
3	50Φ Waste pipe	LM	80		
4	100Φ Waste pipe	LM	200		
	Extra over MuPVC waste pipework for the following:				
5	32Φ 90 degree sweep Bend	No.	48		
6	40Φ 90 degree sweep Bend	No.	56		
7	50Φ 90 degree sweep Bend	No.	24		
8	100Φ 90 degree sweep Bend	No.	24		
9	32Φ Sweep Tee	No.			
10	40Φ Sweep Tee	No.	20		
11	50Φ Sweep Tee	No.	20		
12	100Φ Sweep Tee	No.			
13	100Φ Double Branch	No.			
14	32Φ Access plug	No.	16		
15	40Φ Access plug	No.	20		
16	50Φ Access plug	No.	4		
17	100Φ Access plug	No.			
18	32mm dia - socket	No.	12		
19	40mm dia - socket	No.	8		
20	50mm dia - socket	No.			
21	100mm dia - socket	No.			
	TOTAL TO NEXT PAGE				

ITEM	DESCRIPTION	UNIT	QTY	RATE	AMOUNT
	<i>Balance brought forward</i>				
22	50 x 32mm dia - socket reducer	No.	12		
23	50 x 40mm dia - socket reducer	No.	8		
24	100 x 50mm dia - Boss connectors	No.			
25	100 x 50 Floor traps complete with Plastic Grating	No.	32		
26	100Φ Vent Cowl	No.			
27	Allow for 2" PVC pipe sleeves through/ on side of the columns in bathrooms	LM	8		
Total for 1 No. Floor					
					9.00
Total for 9 No. Floor					
TOTAL TO INTERNAL DRAINAGE COLLECTION PAGE					

ITEM	DESCRIPTION	UNIT	QTY	RATE	AMOUNT
D	INTERNAL DRAINAGE COLLECTION PAGE				
I	Ground Floor				
II	Typical 1st To 9th Floor				
	Sub Total For 1No. Block				
	Total For 2No. Blocks				2.00
	TOTAL TO MAIN SUMMARY PAGE				

ITEM	DESCRIPTION	UNIT	QTY	RATE	AMOUNT
E	<u>EXTERNAL FOUL DRAINAGE</u>				
	Supply, deliver and install uPVC rainwater system to BS 4576 and BS 6367 with screwed and socketed joints to BS 21. Tenderers must allow in their pipework prices for Galvanised Support Brackets after every 1.5 Mts for the Horizontal runs and every 2mts for the vertical runs/w EPDM Rubber insulation material, Clamping screw, Noise reduction of 18.5dBA, Threaded Rod, Bolts & all the couplings, connectors, joints etc.required in the running length of pipework and also where necessary, for pipe fixing clips, holderbats plugged and screwed, brackets and pipe sleeves through structural members. The installation must comply with BS 6367				
	<u>Below Ground</u>				
	<u>MuPVC waste System conforming to BS 5255</u>				
1	100.4.40 Soil and Vent pipe	LM	75		
2	100.6.60 Soil and Vent pipe	LM	230		
3	101.4.90 Sweep bend	No.	30		
4	100Φ 45 degree sweep Bend	No.	6		
5	104.6.92 Single branch	No.	10		
6	136.4 Access Cap	No.	30		
	<u>Gully Trap - Concrete Cover</u>				
7	Allow for a masonry gully trap of size 300 x 300 x450 mm deep with cast Iron P-Trap, cast iron grating, drain pipe, concrete cover, etc.	No.	40		
	<u>Inspection Chambers</u>				
8	Allow excavation and concreting to Class 1:3:6, walling 150 mm thick solid concrete block walls with 1:3 mortar and plastering to 1:2, rectangular Cast Iron heavy duty cover and MS frame with double air seal for manhole not exceeding 1000 mm depth.	No.	40		
	Sub Total For 1No. Block				
	Total For 2No. Blocks				2.00
TOTAL TO MAIN SUMMARY PAGE					

ITEM	DESCRIPTION	UNIT	QTY	RATE	AMOUNT
F	<p><u>RAINWATER DRAINAGE</u></p> <p>Supply, deliver and install uPVC rainwater system to BS 4576 and BS 6367 with screwed and socketed joints to BS 21. Tenderers must allow in their pipework prices for Galvanised Support Brackets after every 1.5 Mts for the Horizontal runs and every 2mts for the vertical runs c/w EPDM Rubber insulation material, Clamping screw, Noise reduction of 18.5dBA, Threaded Rod, Bolts & all the couplings, connectors, joints etc.required in the running length of pipework and also where necessary, for pipe fixing clips, holderbats plugged and screwed, brackets and pipe sleeves through structural members. The installation must comply with BS 6367</p> <p><u>uPVC Rainwater system conforming to BS 4576</u></p>				
1	100mm dia pipe	LM	720		
2	100mm Sweep bend	No.	20		
3	100mm dia Fulbora Outlets	No	20		
	Sub Total For 1No. Block				
	Total For 2No. Blocks				2.00
	TOTAL TO MAIN SUMMARY PAGE				

ITEM	DESCRIPTION	UNIT	QTY	RATE	AMOUNT
G	<u>HOSEREELS, FIRE EXTINGUISHERS</u> Supply , deliver and install Black Pipe to BS 1387 Class C , welded joints to BS21 and Grooved fittings including fixing and jointing to the automatic fire sprinkler system(Light Hazard) in the entire hotel building. Tenderers must allow in their pipework prices for Galvanised Support Brackets after every 1.5 Mts for the Horizontal runs and every 2mts for the vertical runs c/w EPDM Rubber insulation material, Clamping screw, Noise reduction of 18.5dBA, Threaded Rod, Bolts & all the couplings, connectors, joints etc.required in the running length of pipework and also where necessary, for pipe fixing clips, holderbats plugged and screwed, brackets and pipe sleeves through structural members.				
1	25mm diameter Black Pipe	Lm	25		
2	50mm diameter ditto	Lm	80		
	<u>Extra over GMS tubing for the following:</u>				
3	25mm diameter Black Pipe elbow	No.	20		
4	50mm dia ditto	No.	2		
	<u>Tees</u>				
5	25mm Black Pipe equal tee	No.	9		
6	50mm ditto	No.	5		
	<u>Reducing Bushes</u>				
7	25 x 20mm Black Pipe reducing bush	No.	10		
8	50 x 25 mm ditto	No.	10		
	<u>Coupler</u>				
9	25mm diameter Coupler	No.	3		
10	50mm ditto	No.	12		
	<u>Gate Valves</u>				
11	25mm dia high pressure screw- down full way non-rising stem solid wedge disc gate valve to BS 5154 PN 16 for Series B Rating with wheel head and joints to steel tubing. As "Crane Model 156 " or equal and approved	No.	10		
12	50mm ditto	No.	2		
	<u>Pressure Gauge</u>				
13	50mm diameter Pressure Gauge as Pakkens or equal and approved	No.	1		
	<u>Hosereels</u>				
14	Non recessed swinging type hosereel complete with 30 metres of 20mm internal diameter rubber fire hose with nylon spray/jet shut off nozzle , conforming to BS 5274 complete with 25mm diameter Pressure Gauge as Pakkens or equal and approved	No.	10		
15	Wire brush , clean, and paint complete installation with one coat of red oxide primer, undercoat, and gloss coat to Architects colour including banding and colour coding to British Standards	Sum	1		
	<u>Fire Extinguishers</u>				
16	5kg portable water/CO2 (gas cartridge) fire extinguisher conforming to BS 5423 complete with support brackets	No.	10		
17	9 kg portable dry chemical powder extinguisher conforming to BS 5423 complete with support brackets and approvedopriate charge of powder and CO2 cartridge.	No.	10		
18	12kg automatic Dry Powder Fire Extinguisher mounted over generators, witch room	No.	3		
	TOTAL TO NEXT PAGE				

ITEM	DESCRIPTION	UNIT	QTY	RATE	AMOUNT
	<i>Balance brought forward</i>				
19	Supply and fix signs indicating the words "FIRE POINT" in 80mm high letters	No.	20		
20	50mm non-return valve	No.	1		
21	50mm dia in-line strainer	No.	1		
	<u>Automatic Hosereel Pumpsets</u>				
22	Automatic fire hosereel pumpsets of the multistage centrifugal type as Grundfos rated at 15Cu.m/hr. against a head of 15 metres complete with diaphragm pressure tank, pressure switches and base. Unit to consist of 2No. pumps, for duty and standby operation.	Set	1		
23	Automatic electrical control panel for the two hosereel pumpsets as per general specification	No.	1		
24	Electrical wiring from local supply left within 10 metres within the pump room to control panel, from control panel to electric motors and from level controls to control panel.	Sum	1		
25	Allow for 50mm dia. Pressure Reducing Valve	No.	2		
	Sub Total For 1No. Block				
	Total For 2No. Blocks				2.00
TOTAL TO MAIN SUMMARY PAGE					

ITEM	DESCRIPTION	UNIT	QTY	RATE	AMOUNT
H	<u>WATER RETICULATION & BOOSTED MAINS</u>				
	<u>Domestic Booster Pump Set</u>				
1	Automatic single operation pumping set comprising of 3 No. pumps as, 1No. duty, 1No. Assist, and 1No. Standby with three pumps having a cumulative discharge of 48 m³/hr against a head of 75 m complete with integral control panel with pump cyclic controls, Pressure Vessel, float switch controls, Dry run protection, pressure gauge, common steel base frame, interconnecting pipework, isolating valves, non return valves, unions etc as necessary.	Set	1		
	<u>Float Switch & Cable</u>				
2	RC tank low water level cut out float switch, Pressed Steel roof tank high level and low level cut out float switch inclusive of cables and laying from the pump control panel to the controls float switches. (Approx. 80 metres).	Item	1		
	<u>Painting & Colour Coding</u>				
3	Allow for painting of the whole of the plumbing installation with one coat of primer and two finishing coats in accordance with BS1710 specifications and labelling to the satisfaction of the Engineer.	Sum	1		
	<u>Connection to Local Authority Water Mains</u>				
4	Allow for application on behalf of Client and be responsible for water connection to the main supply pipe including liaison with the local authority	Sum	1		
	<u>Bulky Water Meter</u>				
5	Allow for 50 mm diameter "Kent" Council water meter	No.	2		
	<u>Valve/Meter Chamber</u>				
6	Allow for a masonry valve chamber for 50 mm diameter valve and above of size 600 x 600 x 450 mm maximum depth with reinforced concrete cover with mild steel frame conforming to local authority requirements.	No.	2		
	<u>Hose Taps</u>				
7	Heavy duty, chrome plated 1/2" hose bibcock with star handles complete with GI stand pipe and support, and hose union	No.	3		
	<u>Excavation</u>				
8	Excavate trench for buried drain pipes not exceeding 1000 mm and average 600 mm deep, part return, fill in, ram and remainder cart away.	LM	0		
9	Allow for bracketing of pipes in vertical and horizontal runs after evry 1.5m	Sum	1		
10	Concrete surround for pipe across driveway	LM	0		
	<u>Pump Room</u>				
11	50mm dia galvanised mild steel puddle flange manufactured from BS 1387 Class C pipe with flanges made of 15mm thick mild steel plate, all hot dipped galvanised after manufacture and treated with primer and finishing coats of colas bitumastic-Council inlet, Borehole inlet, float switch cables, domestic outlets	No.	16		
12	75mm dia galvanised mild steel puddle flange manufactured from BS 1387 Class C pipe with flanges made of 15mm thick mild steel plate, all hot dipped galvanised after manufacture and treated with primer and finishing coats of colas bitumastic-Overflow	No.	2		
13	150mm dia galvanised mild steel puddle flange manufactured from BS 1387 Class C pipe with flanges made of 15mm thick mild steel plate, all hot dipped galvanised after manufacture and treated with primer and finishing coats of colas bitumastic-Provision for fire discharge	No.	6		
14	RC Underground Water Tank 150,000 Litres Capacity	No.	1	MC	MC
15	50mm dia High Pressure Ball float Valve	No.	4		
16	GI Tank breather C/W insect Screen and bends 150mm dia	No.	2		
	TOTAL TO NEXT PAGE				

ITEM	DESCRIPTION	UNIT	QTY	RATE	AMOUNT
	<i>Balance brought forward</i>				
	<u>Pump Room Sump Pumps</u>				
17	2No. automatic electric motor driven submersible water pumpsets. Pump capacity 10m ³ /hr at 10m head. Pumps to be installed in a sump constructed in the basement store. Pumps to be complete with dirty water level switch and control panel for the two pumps. Pump to be as Pedrollo Top 3 range PI= 0.55kW or equal and approved in duty-standby operation.	Set	1		
	<u>Lift Sump Pumps</u>				
18	2No. automatic electric motor driven submersible water pumpsets. Pump capacity 10m ³ /hr at 10m head. Pumps to be installed in a sump constructed in the basement store. Pumps to be complete with dirty water level switch and control panel for the two pumps. Pump to be as Pedrollo Top 3 range PI= 0.55kW or equal and approved in duty-standby operation.	Set	2		
19	32mm diameter PPR Pipes	Lm	10		
20	32mm diameter PPR Elbows	No.	2		
21	32 x1 3/4"ø dia threaded adaptors (Brass threads).	No.	4		
22	800x600mm mild steel sheet hinged cover complete with mild steel frame, and padlock. Cover and frame to be painted with corrosion resistant zinc primer and paint.	No.	1		
23	Allow for Stainless Steel Cat Ladder	Item	1		
	<u>Water Supply Pipes From Underground Tank To Each Block</u>				
	Supply, deliver and install- Cold Water, Corrosion Resistant HDPE water supply pipes Tenderers must allow in their pipework prices for all the couplings, connectors, adaptors, joints etc. required in the running length of pipework and also where necessary, for pipe fixing clips, holderbats plugged and screwed, brackets and pipe sleeves through structural members.				
24	75mm diameter HDPE Pipes supply	LM	350		
25	50mm diameter HDPE Pipes supply	LM	40		
	<u>Extra over HDPE pipe</u>				
26	75 mm dia. Bend	No.	8		
27	50 mm dia. Bend	No.	6		
	<u>Gate Valve</u>				
27	50mm dia approved high pressure screw- down full way non-rising stem solid wedge disc gate valve to BS 5154 PN 16 for Series B Rating with wheel head and joints to steel tubing. As "Crane Model 156 "	Nos	4		
28	75mm ditto	Nos	4		
	<u>Non Return Valve</u>				
29	50mm dia approved high pressure Non-Return Valve As Crane Model	Nos	6		
	<u>HDPE Female threaded adaptors (Brass threads).</u>				
30	50x 2"ø dia Female threaded adaptors (Brass threads).	No.	6		
31	50mm Bulk meter as Kent	Nos	4		
	<u>Excavation</u>				
32	Excavate trench for buried drain pipes not exceeding 1000 mm and average 600 mm deep, part return, fill in with quarry dust along driveway, ram and remainder cart away.	LM	400		
TOTAL TO MAIN SUMMARY PAGE					

ITEM	DESCRIPTION	UNIT	QTY	RATE	AMOUNT
I	<u>INTERNAL PLUMBING - RISERS, DROPPERS, & ROOF</u>				
	Supply, deliver and install PN20 PPR pipes and fittings for sizes up to 110mm for cold water. Tenderers must allow in their pipework prices for all the couplings, connectors, joints etc. required in the running length of pipework and also where necessary, for pipe fixing clips, holder bats plugged and screwed, brackets, and pipe sleeves through structural members. The solvent weld shall be by a heat gun as recommended by the manufacturer.				
	Cold Water				
1	32mm diameter PPR Pipes	Lm	50		
2	40mm diameter PPR Pipes	Lm	50		
3	50mm diameter PPR Pipes-Rising Main	Lm	80		
4	50mm diameter PPR Pipes - Dropper for 2nd and 3rd Floors	Lm	100		
5	63mm diameter PPR Pipes Dropper from Roof Tank to Wet Areas	Lm	480		
5	100mm diameter GI Pipes at Roof Terrace Painted	Lm	80		
	Extra over PPR tubing for the following:				
6	32mm diameter PPR 90° elbow	No.	15		
7	40mm diameter PPR 90° elbow	No.	4		
8	50mm diameter PPR 90° elbow	No.	6		
9	63mm diameter PPR 90° elbow	No.	24		
9	100mm diameter GI 90° elbow painted	No.	12		
	<u>Tees</u>				
10	32 mm diameter PPR equal tee	No.	12		
11	40 mm diameter PPR equal tee	No.	5		
12	50 mm diameter PPR equal tee	No.	20		
13	63mm diameter PPR 90° equal tee	No.	160		
12	100 mm diameter GI equal tee painted	No.	14		
14	32x25mm diameter PPR reducer coupling	No.	14		
15	40x32mm diameter PPR reducer coupling	No.	14		
16	63x50mm diameter PPR reducer coupling	No.	14		
16	100x63mm diameter GI-PPR reducer coupling painted	No.	20		
	<u>Unions</u>				
17	32mm diameter PPR socket	No.	8		
18	40mm diameter PPR socket	No.	8		
19	50 mm diameter PPR socket	No.	24		
20	63 mm diameter PPR socket	No.	60		
20	100 mm diameter GI socket painted	No.	10		
	TOTAL TO NEXT PAGE				

ITEM	DESCRIPTION	UNIT	QTY	RATE	AMOUNT
	<i>Balance brought forward</i>				
	Gate Valves				
21	32mm dia approved high pressure screw- down full way non-rising stem solid wedge disc gate valve to BS 5154 PN 16 for Series B Rating with wheel head and joints to steel tubing. As "Crane Model 156 "	No.	12		
22	40mm ditto	No.	12		
23	50mm ditto	No.	20		
24	63mm ditto	No.	20		
25	100mm ditto	No.	1		
	PPR Male/Female threaded adaptors (Brass threads).				
26	32 x1 1/4"o dia threaded adaptors (Brass threads).	No.	5		
27	40 x1 1/2"o dia threaded adaptors (Brass threads).	No.	5		
26	50 x2"o dia threaded adaptors (Brass threads).	No.	5		
27	63 x2 1/2"o dia threaded adaptors (Brass threads).	No.	5		
28	100 x 4"o dia GI threaded adaptors (Brass threads). Painted	No.	2		
	Roof Water Tanks				
29	Supply, Deliver, Install and Test external flanged Press Steel tank Size: 5000x5000x2000mm high complete with. 1 No. 50mm dia tank supply 1 No. 80mm dia washout with gate valve, 1No. 100mm domestic discharge, 1No.50mm FHR discharge, 1 No. 75mm dia overflow Capacity: 50,000 litres Tank to be supplied with 1No.50mm diameter High Pressure brass float valve. Tank to be supported as per Structural Engineers details	No.	2		
30	50mm diameter Pressure reducing valve with self-contained replaceable cartridge. Brass body. With pressure regulating scale for manual pressure adjustment. Stainless steel strainer cartridge with transparent housing, With replacement strainer and key to service strainer and cartridge, Male union connections, Strainer mesh size Ø: 0,28 mm,Max. working temperature: 40°C Certified to EN 1567.	No.	2		
	Sub Total For 1No. Block				
	Total For 2No. Blocks				2.00
	TOTAL TO MAIN SUMMARY PAGE				

ITEM	DESCRIPTION	UNIT	QTY	RATE	AMOUNT
<u>MAIN SUMMARY PAGE</u>					
A	Preliminary				
B	Sanitary Fittings Supply & Install				
C	Internal Plumbing				
D	Internal Foul Drainage				
E	External Foul Drainage				
F	Rainwater Drainage				
G	Hosereel System				
H	Water Reticulation & Boosted Mains				
I	Internal Plumbing-Risers, Droppers, and Roof				
TOTAL COST FOR MECHANICAL WORKS (INCL 16% VAT)					

Amount in Words: Kenya Shillings.....

.....

.....

Official Stamp & Address:.....

.....

Tenderer's Signature:.....Date:.....

Witness' Name:.....Witness' Signature:.....

Address:.....

Date:.....

GUARD HOUSE

ITEM	DESCRIPTION	UNIT	QTY	RATE	AMOUNT
BILL NO.1-BUILDERS WORKS					
ELEMENT NO 1 - SUBSTRUCTURES (ALL PROVISIONAL)					
Site Clearance					
A	Clear site of all grass, hedges, shrubs, bushes including grubbing up of roots, cart away arising debris and burn them.	SM	12		
Excavations					
B	Excavate for vegetable soil average 150 mm deep: and set aside for later reuse in landscaping	SM	12		
C	Excavate manually for reduced level depth not exceeding 1.5 metres commencing from stripped level	CM	14		
D	Excavate for Strip foundations depth not exceeding 1.50 metres starting from reduced level	CM	14		
E	Extra over excavation for excavating in all classes of rock	CM	3		
Disposal of water					
F	Allow an item for keeping all excavations free from all spring and running water by pumping or any other such means.	ITEM	1		
Planking and strutting					
G	Allow an item for maintaining and upholding the sides of excavations and keeping excavations clear of all fallen materials.	ITEM	1		
Carried to collection					

ITEM	DESCRIPTION	UNIT	QTY	RATE	AMOUNT
	Disposal of excavated materials				
A	Return, fill and ram selected excavated material around foundations.	CM	10		
B	Load,wheel and cart away surplus excavated material away from site	CM	9		
	Fillings				
C	Make up levels using approved imported materials: compacted in layers not exceeding 300mm thick with a 15ton roller: to the satisfaction of the Structural Engineer.	CM	6		
D	300mm thick hardcore filling,hand packed and compacted in layers not exceeding 150mm thick to the entire satisfaction of the Structural Engineer;with 50mm Thick murrum blinding or "equal and approved" on top surface (measured separately)	SM	10		
E	50 mm Thick Murrum Blinding to surfaces of hadcore	SM	10		
	Anti - termite treatment				
F	Approved anti-termite chemical treatment with 10 years guarantee,sprayed to the surfaces of hardcore in strict adherence to manufacture's instruction.	SM	10		
	Damp-proof membrane				
G	1000 gauge polythene or other equal and approved damp-proof membrane, laid over blinded hardcore (measured separately) with 300mm side and end laps (measured nett-allow for laps)	SM	10		
	Insitu class 15 / 20 mm aggregates as described in:				
H	50 mm Thick under strip foundation	SM	10		
	Insitu concrete class 25 (20mm maximum aggregate size):vibrated and reinforced:				
J	Strip foundation	CM	1		
K	100mm thick ground slab	SM	10		
	Carried to collection				

ITEM	DESCRIPTION	UNIT	QTY	RATE	AMOUNT
	Ribbed reinforcement bars to BS 4449:2005 , Grade 500 high tensile strength, including all necessary bends, hooks, tying wires and distance blocks (Provisional):				
A	Assorted reinforcement	KG	16		
B	T12	KG	43		
	Mesh fabric reinforcement to BS 4483 BRC A142; 200 x 200mm, weighing 2.22kg/m² (measured net - no allowance for laps; in two layers - top & bottom; including bends, tying wire and spacer blocks				
C	In ground slab	SM	10		
	Modular steel frame with 5mm thick steel plates covering formwork and/or marine board formwork: to:				
D	Sides of Strip footing	SM	6		
E	Edge of slab not exceeding 150mm girth	LM	13		
	Foundation Wall				
	<u>Natural quarry stones rough dressed with a minimum compressive strength of 7.0N/mm² average compressive strength to BS 5390;bedded and jointed in cement and sand(1:4) mortar;reinforced with 25 x 3mm thick iron strips at alternate courses.</u>				
F	200mm thick walls in foundations	SM	24		
	<u>Plinth</u>				
	<u>25mm Thick cement and sand (1:4) render on concrete or masonry ; wood float finished; to</u>				
G	Plinths; externally.	SM	7		
	<u>Two coats black bituminous paint on:</u>				
H	Rendered surfaces	SM	7		
	Carried to collection				

ITEM	DESCRIPTION	UNIT	QTY	RATE	AMOUNT
	COLLECTION				
	Total brought forward from page no: GH/1				
	Total brought forward from page no: GH/2				
	Total brought forward from page no: GH/3				
	ELEMENT NO. 1				
	Carried to				
	SUBSTRUCTURES				
	Main summary				

ITEM	DESCRIPTION	UNIT	QTY	RATE	AMOUNT
BILL NO.1-BUILDERS WORKS					
ELEMENT No 2 - R.C FRAME					
Insitu concrete class 25 (20mm maximum aggregate size):vibrated and reinforced:					
A	Beams	CM	1		
Ribbed reinforcement bars to BS 4449:2005 , Grade 500 high tensile strength, including all necessary bends, hooks, tying wires and distance blocks (Provisional):					
B	Assorted reinforcement bars	KG	111		
Modular steel frame with 5mm thick steel plates covering formwork and/or marine board formwork: to:					
C	Sides and soffites of beams	SM	10		
	<u>ELEMENT NO. 2</u> Carried to <u>R.C FRAME</u> Main summary				

ITEM	DESCRIPTION	UNIT	QTY	RATE	AMOUNT
	BILL NO.1-BUILDERS WORKS				
	ELEMENT No 3-WALLING				
	<u>EXTERNAL WALLING</u>				
	Machine cut natural quarry stone walling with minimum compressive strength to B.S 5390; bedded and jointed in cement and sand (1:4) ;and reinforced with and including 25mm wide x 3mm hoop iron at every alternate course as described in;				
A	150mm thick walls	SM	22		
	<u>INTERNAL WALLS</u>				
	Machine cut natural quarry stone walling with minimum compressive strength to B.S 5390; bedded and jointed in cement and sand (1:4) mortar;and reinforced with and including 25mm wide x 3mm hoop iron at every alternate course as described in;				
B	150mm thick walling Internally	SM	2		
C	200mm Wide damp proof course to B.S 743 Type A bitumen hessian based 150 mm laps (no allowance made for laps); horizontal, 1 No. layer, bedded in and including cement and sand (1:3) mortar	LM	16		
	<u>ELEMENT NO. 3</u> Carried to				
	<u>WALLING</u> Main summary				

ITEM	DESCRIPTION	UNIT	QTY	RATE	AMOUNT
BILL NO.1-BUILDERS WORKS					
ELEMENT NO 4 - WINDOWS					
<u>PURPOSE - MADE UNITS</u>					
<p><u>Supply, fabricate and fix the following purpose made small pane mild steel casement windows to be fabricated from approved mild steel sections (at least 14g 2mm thick) comprising of frame and casement incorporating permanent hooded high level ventilation panels in filled with mosquito gauze : window supplied complete with and including 12mm solid square burglar proofing bars fixed at 200mm centers both ways and metal fixing lugs including building into wall and making good, and all necessary iron mongery viz hinges, fasteners, and hasp including shop priming window with red oxide primer before delivery to site:-</u></p>					
A	Window, overall size 1200 X 1500mm high to Architects Details (Lounge. Kitchen, Bedroom)	NO	2		
B	Ditto Size 600 x 900mm high (WC/SH)	NO	1		
<u>Glazing</u>					
C	4mm Thick clear sheet glass panes over 0.1 but not exceeding 0.5 square meters; fixing with putty	SM	4		
D	Ditto; obscure	SM	1		
<u>Painting and Decorations</u>					
<p><u>Prepare surfaces and apply two coats of first grade quality gloss oil paint as manufactured by Crown Solo Paints or equal and approved on;</u></p>					
E	General window and grille surfaces; internally and externally	SM	5		
Carried to Collection					

ITEM	DESCRIPTION	UNIT	QTY	RATE	AMOUNT
	<p><u>Bull-nosed burnt clay, finishing fair on all exposed surfaces and hoisting and placing in position, bedding, jointing and pointing in pigmented cement and sand (1:3) mortar</u></p>				
A	150 x 25mm thick clay window sill	LM	3		
	<p><u>Curtain rods:</u></p>				
B	20mm diameter heavy duty twin brass rod complete accessories to approval	LM	2		
	<p>Carried to collection</p>				
	<p>COLLECTION</p>				
	Total brought forward from page no: GH/7				
	Total brought forward from page no: GH/8				
<p><u>ELEMENT NO. 4</u></p> <p><u>WINDOWS</u></p>	<p>Carried to the</p> <p>Main summary</p>				

ITEM	DESCRIPTION	UNIT	QTY	RATE	AMOUNT
	BILL NO.1-BUILDERS WORKS				
	ELEMENT NO 5 - DOORS				
	<u>Steel Casement Door</u>				
	<u>Supply and fix the the following purpose made mild steel door comprising 40 x 25 x3mm stiles, top and bottom stiles, 4 No Intermediate rails, 1.5mm steel sheet both sides welded in place and 4mm thick clear glazing, all primed with red oxide and spray painted 2 coats of first quality gloss paint from Crown Solo paints or equal and approved ; complete with all necessary ironmongery fasteners and necessary seremetals assembled and fixed to opening including cutting and pinning lugs to concrete or block work sorroundingg and bedding frame in cement and sand mortar (1:3).</u>				
A	Door size 900 x 2100mm high (D.01) 50mm thick semi solid cored flush door Ply wood facing finished for painting (m/s) both sides; hardwood lipped edges:all to Architects specifications and approval	NO	1		
B	Door size 1200mm x 2100mm Frames and frame finishes in wrot softwood	NO	1		
C	25 x 25mm quadrant	LM	5		
D	25 x 50mm architrave with two labours, plugged	LM	5		
E	50 x 150mm frame with three labours; chamfered edges; plugged	LM	5		
	Carried to collection				

ITEM	DESCRIPTION	UNIT	QTY	RATE	AMOUNT
	<u>Painting and decorating</u>				
	<u>Prepare and apply one coat aluminium wood primer to:-</u>				
A	Surfaces not exceeding 100mm girth	LM	10		
B	Surfaces over 100mm but not exceeding 200mm girth	LM	5		
C	General timber surfaces	SM	3		
	Ironmongery				
	<u>Supply and Fix the following ironmongery to the approval of the Architect</u>				
D	100mm pressed steel Butt Hinges	Prs	2		
E	2 Lever Door Lock with handles as per Union or equal and approved.	NO	1		
F	Door fixing cramps	NO	4		
G	Rubber Door Stops	NO	1		
	Carried to Collection				
	COLLECTION				
	Total brought forward from page no: GH/9				
	Total brought forward from page no: GH/10				
	ELEMENT NO. 5				
	DOORS				
	Carried to Main summary				

ITEM	DESCRIPTION	UNIT	QTY	RATE	AMOUNT
	BILL NO.1-BUILDERS WORKS ELEMENT NO 6 - EXTERNAL AND INTERNAL FINISHES				
	EXTERNAL WALL FINISHES				
A	Extra over vertical and horizontal key pointing in 10 mm rod in cement and sand mix (1:3) mortar including one coat of Bituminous paint	SM	22		
	INTERNAL FINISHES				
	<u>12mm (minimum) two coat lime plaster complete with wire gauze anti-crack mechanism at the intersection of masonry walling and concrete beams as described to:-</u>				
B	Concrete/masonry surfaces Internally	SM	13		
C	Ditto to window cills, door Jambs Externally and Surfaces not exceeding 200mm girth	LM	17		
	<u>12mm thick Cement and sand (1:3) backing on blockwork, prepared to receive ceramic wall tiles to:</u>				
D	Walls (wet areas)	SM	9		
	<u>Ceramic wall tiles</u>				
E	Supply and fix 200x200x6mm thick wall tiles as manufactured by Saj ceramic wall tiles or equal and approved; bedded and jointed in matching coloured proprietary grout on prepared on prepared backings(m.s); jointed and pointed in matching coloured proprietary grouting; including pvc spacers and expansion joint as necessary: all to Architect's approval. - Wall Surfaces	SM	9		
	<u>Painting and Decoration</u>				
	<u>Prepare and apply one undercoat and one finishing coat of first quality plastic emulsion as manufactured by Crown Solo paints or equal and approved on :-</u>				
F	Plastered concrete/masonry surfaces internally	SM	13		
G	Ditto to window cills, door Jambs Externally and Surfaces not exceeding 200mm girth	LM	17		
	Carried to collection				

ITEM	DESCRIPTION	UNIT	QTY	RATE	AMOUNT
	<u>Floor Finishes</u>				
	<u>32 mm thick Cement and sand (1:3) backing on concrete surfaces,prepared to receive ceramic floor tiles to:</u>				
A	Floor surfaces	SM	8		
	<u>Ceramic Floor tiles</u>				
B	Supply and Fix 300x300 x 8mm thick thick Ceramic tiles or equal and approved; as manufactured by Saj ceramic wall tiles or equal and approved; bedded and jointed in matching coloured proprietary grout on prepared on prepared backings(m.s); jointed and pointed in matching coloured proprietary grouting: including pvc spacers and expansion joint as necessary: all to Architect's approval - Floor Surfaces	SM	5		
C	Ditto Non Slip Ceramic Tiles	SM	3		
D	Ditto 100mm wide Wall Skirtings	LM	14		
	Carried to Collection				
	COLLECTION				
	Total brought forward from page no: GH/11				
	Total brought forward from page no: GH/12				
	ELEMENT NO 6: TOTAL FOR FINISHES				

ITEM	DESCRIPTION	UNIT	QTY	RATE	AMOUNT
	ELEMENT NO. 7				
	ROOF CONSTRUCTION AND FINISHES				
	Sawn celcured pressure impregnated cypress				
	The following 4 No. trusses spanning at various lengths at 600mm c/c and 2.85 m from ground level.				
	Truss T1 (4 no.)				
A	150 x 50 truss rafters	LM	11		
B	150 x 50 mm King post	LM	3		
C	Ditto struts and ties	LM	11		
D	Ditto tie beam	LM	10		
E	100 x 50 wall plate.	LM	13		
F	Ditto purlins	LM	12		
	End of trusses				
	ROOF COVERING				
	<u>30 Gauge corrugated galvanized prepainted iron sheet fixed on roof structure (ms)</u>				
G	Ridge	LM	4		
H	Roof covering	SM	12		
	Sundries				
	<u>In wrot cypress - prime grade</u>				
J	250 x 25mm fascia board	LM	4		
K	250 x 25mm barge board	LM	5		
L	100 x 20 mm T & G in eaves boarding on 50 x 50mm softwood brandering	SM	2		
M	25 x 100 mm moulded cornice.	LM	13		
	Roof drainage				
	<u>24 Gauge galvanised steel sheet shaped as required</u>				
N	150 x 150 mm GI rain water gutter fixed to fascia board with mild steel brackets at 1.50 m centres.	LM	4		
P	Extra over ditto for stopped ends	No	2		
Q	Extra over for 100mm diameter outlet	No	2		
	Carried to collection				

ITEM	DESCRIPTION	UNIT	QTY	RATE	AMOUNT
A	100mm diameter down pipe fixed to walls with mild steel brackets at 1.50 m centres.	LM	5		
B	Extra over ditto for swan neck offset.	No	2		
C	Ditto for splash shoe.	No	2		
D	12 mm diameter x 150 mm holding down bolt with head, nut and washers.	No.	26		
	Painting and decorating				
	<u>Prepare and apply three coats of gloss paint to timber surfaces</u>				
E	Wood surfaces 200 - 300mm girth	LM	7		
	<u>Knot, prime, stop and apply one 3 coats of polyurethane varnish to:-</u>				
F	Wood general surfaces externally.	SM	10		
G	Surfaces of timber cornices, 0-100mm girth.	LM	13		
	<u>Parapet wall</u>				
H	150mm thick masonry parapet wall as per architects approval	SM	5		
	<u>Plaster and paint</u>				
J	Prepare and plaster with cement and sand screed (1;3) 12mm thick to receive paint	SM	5		
	<u>Painting and decoration</u>				
K	Prepare and apply one undercoat and two finishing coats of vinylmatt or equal and approved as per architect's details on parapet wall	SM	5		
	<u>Ceiling finishes</u>				
L	Prepare and install Celotex ceiling or approved equivalent as per architects' approval.	SM	10		
	<u>Blandering</u>				
M	50 x 50 mm timber blandering spaced 600mm c/c as per architects approval	LM	41		
	Carried to Collection				
	COLLECTION				
	Total brought forward from page no: GH/13				
	Total brought forward from page no: GH/14				
	ELEMENT NO. 7 _____				
	ROOF CONSTRUCTION AND FINISHES				

ITEM	DESCRIPTION	UNIT	QTY	RATE	AMOUNT
	<p>ELEMENT NO. 8</p> <p>PROVISIONAL SUMS</p> <p>Allow a provisional sum of Kenya Shillings Fifty Thousand (KSHS. 50,000) for electrical installation and connection works to the guard house per Engineers specification.</p> <p>Allow a provisional sum of Kenya Shillings One hundred Thousand (KSHS. 100,000) for mechanical installation and connection works to the guard house per Engineers specification.</p>				
A		SUM	1		
B		SUM	1		
	<p>ELEMENT NO. 8</p> <p>PROVISIONAL SUMS</p>				

ITEM	DESCRIPTION	UNIT	QTY	RATE	AMOUNT
BILL NO.1-BUILDERS WORKS					
MAIN SUMMARY					
1	Substructures		GH/4		
2	Reinforced Concrete Frame		GH/5		
3	Walling		GH/6		
4	Windows		GH/8		
5	Doors		GH/10		
6	External and Internal Finishes		GH/12		
7	Roof construction and finishes		GH/14		
8	Provisional sums		GH/15		
<u>TOTAL FOR 1NO. GUARD HOUSE</u>					
NO. OF BLOCKS			2		
MULTIPLY BY 2.NO OF BLOCKS		X 2			
<u>TOTAL FOR 2 NO. GUARD HOUSE CARRIED TO GRAND SUMMARY</u>					

GARBAGE RECEPTACLE

ITEM	DESCRIPTION	UNIT	QTY	RATE	AMOUNT
BILL NO.10-BUILDERS WORKS					
ELEMENT NO 1 - SUBSTRUCTURES (ALL PROVISIONAL)					
<i>Site Clearance</i>					
A	Clear site of all grass, hedges, shrubs, bushes grub up roots, load and remove from site and dispose at designated local authority areas.	SM	14		
B	Excavate average 200mm deep to remove top vegetable soil, load, remove from site and dump in designated local authority dump site.	SM	14		
C	Excavate to reduced levels in varying depths not exceeding 1.5m deep from existing ground levels.	CM	20		
D	Excavate for Strip foundations depth not exceeding 1.50 metres starting from reduced ground levels.	CM	14		
E	Extra over excavation for excavating in soft rock	CM	2		
Carried to collection					

ITEM	DESCRIPTION	UNIT	QTY	RATE	AMOUNT
	<u>Disposal of excavated material</u>				
A	Return, fill and ram selected excavated material around foundations.	CM	9		
B	Load, wheel and cart away surplus excavated material to a Local Authority designated dumping site or fill soil heaps as away from site instructed by the Project Engineer.	CM	29		
	Fillings				
C	Make up levels using approved imported materials: compacted in layers not exceeding 300mm thick with a roller: to the satisfaction of the Structural Engineer.	CM	7		
D	300mm thick hardcore bed: hand packed : compacted in layers not exceeding 150mm thick: to the satisfaction of the Structural Engineer	SM	14		
E	50 mm Thick Murram Blinding to surfaces of hadcore	SM	14		
	Anti - termite to treatment				
F	Approved anti-termite treatment, with ten-year guarantee, sprayed to surfaces of hardcore strictly in accordance with manufacturer's instructions.	SM	14		
	Damp-proof membrane				
G	1000 gauge polythene or other equal and approved damp-proof membrane, laid over blinded hardcore (measured separately) with 300mm side and end laps (measured nett-allow for laps); 1 No. layer: bedded in and including cement and sand (1:3) mortar	SM	14		
	Concrete Blinding				
	In situ concrete class 15/20 mm aggregates: vibrated:				
H	50 mm Thick under strip foundation	SM	9		
	In- situ vibrated reinforced concrete Class 25 (20mm aggregates): in:				
J	Strip foundation	CM	2		
K	100mm thick surface bed	SM	14		
	Carried to collection				

ITEM	DESCRIPTION	UNIT	QTY	RATE	AMOUNT
A	<p>Ribbed reinforcement steel bars to BS4449: 2005: Grade 500 high tensile strength including bends, hooks, tying wire and distance blocks; to S.E's detail (Provisional)</p> <p>Assorted reinforcement</p>	KGS	70		
B	<p>Mesh fabric reinforcement to BS 4483 BRC A142;200 x 200mm, weighing 2.22kg/m² (measured net - no allowance) for laps; in two layers - top & bottom; including bends, tying wire and spacer blocks)</p> <p>In floor beds</p> <p><u>Modular steel frame with 5mm thick steel plates covering formwork and/or marine board formwork:</u> to:</p>	SM	14		
C	Sides of Strip footing	SM	6		
D	Edge of slab not exceeding 150mm girth	LM	15		
	Foundation Walling				
	Natural quarry stones rough dressed; bedded in and including cement and sand (1:4) mortar; reinforced with and including 45 mm wide hoop iron gauge in alternate courses: in:				
E	200mm thick walls in foundations	SM	20		
	<u>Plinth</u>				
	<u>25mm Thick cement and sand (1:4) rendering on concrete or masonry ; wood float finished; to</u>				
F	Plinths externally	SM	8		
	Two coats black bitumastic paint on:				
G	Rendered surfaces	SM	8		
	Carried to collection				

ITEM	DESCRIPTION	UNIT	QTY	RATE	AMOUNT
	COLLECTION				
	Total brought forward from page no: R/1				
	Total brought forward from page no: R/2				
	Total brought forward from page no: R/3				
	<u>ELEMENT NO. 1</u> Carried to				
	SUBSTRUCTURES Main summary				

ITEM	DESCRIPTION	UNIT	QTY	RATE	AMOUNT
BILL NO.1-BUILDERS WORKS					
ELEMENT No 2-WALLING					
<u>WALLING</u>					
<u>External Walling</u>					
<u>Machine cut quarry stone walling with a minimum of 7.0 N/mm2 average compressive strength to B.S 5390;bedded and jointed in cement and sand (1:4) mortar, reinforced with and including 25 x 3 mm thick hoop iron strips at every alternate course as described in;</u>					
A	200mm thick walling Externally	SM	17		
B	Approved hessian based damp proof course to 200mm thick walling in cement/sand mortar	LM	15		
	<u>ELEMENT NO. 2</u> <u>WALLING</u>	Carried to Main summary			

ITEM	DESCRIPTION	UNIT	QTY	RATE	AMOUNT
A	<p>ELEMENT NO 3 - DOORS</p> <p><u>Steel Casement Door</u></p> <p>Supply, fabricate and fix the following purpose made heavy gauge double steel casement door comprising 40 x 25 x3mm stiles, top and bottom stiles, 4 No Intermediate rails, 1.5mm steel sheet both sideswelded in place and 5mm thick clear glazing, all primed with red oxide spray painted with two finishing coats of first quality gloss oil paint on ; complete with all necessary ironmongery fasteners and necessary seremetals assembled and fixed to opening including cutting and pinning lugs to concrete or block work sorround and bedding frame in cement and sand mortar (1:3).</p> <p>Door size 2800 x 1500mm high (D. 01)</p>	NO	1		
	<p><u>ELEMENT NO. 3</u> Carried to</p> <p><u>DOORS</u> Main summary</p>				

ITEM	DESCRIPTION	UNIT	QTY	RATE	AMOUNT
	ELEMENT NO 4 - EXTERNAL FINISHES				
	EXTERNAL WALL FINISHES				
A	Extra over horizontal and vertical pointing in 10mm thick rod in cement and sand mix (1:3) mortar including one coat Bituminous paint	SM	17		
	COPING				
B	300 wide x 50mm thick concrete, coping, throated and weathered, bedding and jointing to walls with cement sand 1:4 mortar	LM	12		
	ELEMENT NO. 4 EXTERNAL FINISHES	Carried to Main summary			

ITEM	DESCRIPTION	UNIT	QTY	RATE	AMOUNT
ELEMENT NO 5 - INTERNAL FINISHES					
<u>Internal Wall Finishes</u>					
<i>Cement and sand (1:4) backing</i>					
A	12mm thick internal walls	SM	17		
<u>Floor Finishes</u>					
<i>Cement and sand (1:3) screeds, backings, beds etc</i>					
B	32mm Thick coloured cement sand screed mix 1:3 finished to approval	SM	14		
<u>ELEMENT NO. 5</u>		Carried to			
INTERNAL FINISHES					

ITEM	DESCRIPTION	UNIT	QTY	RATE	AMOUNT
MAIN SUMMARY					
			<u>PAGE</u>		
1	Substructures		R/4		
2	Walling		R/5		
3	Doors		R/6		
4	External Finishes		R/7		
5	Internal Finishes		R/8		
<u>TOTAL FOR 1NO. GARABAGE RECEPTACLE</u>					
NO. OF BLOCKS					
2					
MULTIPLY BY 2.NO OF BLOCKS					
X 2					
<u>TOTAL FOR 2NO. GARABAGE RECEPTACLES</u> <u>CARRIED TO GRAND SUMMARY</u>					

BASKET BALL PITCH

ITEM	DESCRIPTION	UNIT	QTY	RATE	AMOUNT
<p align="center"><u>PROPOSED APARTMENTS FOR AFFORDABLE HOUSING PROGRAM (BASKET BALL PITCH)</u></p>					
<p>BILL NO.8 BUILDERS WORKS</p>					
<p>Oversite Excavation</p>					
A	Clear site of all grass, hedges, shrubs, bushes grub up roots, load and remove from site and dispose at designated local authority areas.	SM	925		
B	Excavate average 200mm deep to remove top vegetable soil, load, remove from site and dump in designated local authority dump site.	SM	925		
C	Excavate to reduced levels in varying depths not exceeding 1.5m deep from existing ground levels.	CM	324		
D	Load and cart away excess excavated materials as directed on site.	CM	324		
<p align="center">TOTAL FOR EXCAVATIONS CARRIED TO SUMMARY</p>					

ITEM	DESCRIPTION	UNIT	QTY	RATE	AMOUNT
	ELEMENT NO. 2 - BASKET BALL COURT				
	(All provisional)				
	Sub-Grade				
A	Roll and compact subgrade formation to achieve 98% modified proctors MDD including grading to falls and crossfalls	SM	574		
B	Imported and approved murrum backfill materials to make up levels, well watered, rolled and compacted to 98% MDD at optimum moisture content in layers not exceeding 150mm Thick to Engineer's approval	CM	201		
	Sub-Base				
C	150mm thick Compacted gravel 3.5mm in sub-base laid at a slope of 1% well watered and compacted to 98% MDD at optimum moisture content in layers each of 150mm Thick to Engineer's approval	SM	574		
	FINISHINGS				
D	ASPHALT FINISH				
	Prepare surface and spray MC-30 as a prime coat cutback bitumen at a rate of 0.8 -1.0 lt/m2 as prime coat.	SM	574		
E	Prepare primed surfaces, provide and spray K1-60 bitumen emulsion as tack coat at a spray rate of 0.8 - 1.0 lt/m2 as directed by Engineer.	SM	574		
F	75mm thick Asphalt concrete for surfacing	SM	574		
	Channels				
G	Provide, lay and joint Channel, 125x150mm flush channel block, laid on and including 450x100mm concrete (1:3:6) bed and 100x200mm haunching behind including any necessary formwork and disposal of surplus material as directed.	LM	69		
	TOTAL FOR BASKET BALL COURTS CARRIED TO SUMMARY				

ITEM	DESCRIPTION	UNIT	QTY	RATE	AMOUNT
	<p>ELEMENT NO. 3 - WATER DRAINAGE AROUND THE PITCH</p> <p>FRENCH DRAIN</p> <p>Oversite Excavation (All excavations Measured Net)</p> <p>Excavate for French Drain average depth not exceeding 1500mm Deep, uphold the sides of excavation, keep excavations free from water, trim and compact the bottom of excavation to level and cart away the resultant excavated materials as directed on site as described in:</p>				
A	Main-drain	CM	97		
B	Ditto to Sub-drain	CM	5		
	<p>Mass concrete (class 15/20) in;</p> <p>50mm Thick Class 15/20 mass concrete blinding to bottom of trenches to receive drain pipe as described in:</p>				
C	Main-drain	SM	65		
	<p><u>Underground Drain Pipe.</u></p> <p>Supply, lay including necessary jointing and connections approved HDPE Perforated Pipe all to approval as described in:</p>				
D					
E	200mm Diameter main drain.	LM	108		
	<p><u>Hesian Filter Fabric</u></p> <p>Supply and lay approved hesian Filter Fabric to french drains girth 600mm wide.</p>				
F		LM	108		
G	Ditto girth 300mm wide.	LM	34		
	Carried to collection				

ITEM	DESCRIPTION	UNIT	QTY	RATE	AMOUNT
	Drain Fillings.				
A	Approved imported hardcore fillings over perforated underground pipe in main drain.	CM	15		
B	Ditto above formation level on subdrains.	CM	3		
C	Supply and place approved 200mm graded aggregates ballast fillings over perforated underground pipe in main drain.	CM	26		
D	Ditto above formation level on subdrains.	CM	2		
E	Supply and place approved sand fillings over perforated underground pipe in main drain.	CM	13		
F	Ditto above formation level on subdrains.	CM	2		
	Inspection chambers				
G	Construct 600 wide x 600 mm long x 1500 mm deep (internal dimensions) storm water manhole, comprising 150 mm thick concrete class 20 bed, 200 mm thick natural stonewalling in cement and sand (1:3) mortar, 150 mm thick concrete class 20 cover slab with requisite reinforcement, 450x 600 mm heavy duty cast iron cover and frame bedded in cement and sand (1:3) mortar; internally plastered & screeded in 15 mm thick lime plaster; 100 mm thick concrete class 20 benching; complete with necessary excavation, formwork and 2 No. connections to pipes not exceeding 200 mm diameter(pipe m/s)	NO.	7		
	Carried to Collection				
	Collection: Brought forward from page BP/3 Brought forward from page Above				
	TOTAL FOR WATER DRAINAGE AROUND THE PITCH CARRIED TO SUMMARY				

ITEM	DESCRIPTION	UNIT	QTY	RATE	AMOUNT
ELEMENT NO. 4 - BASKET BALL GOAL POSTS					
<u>Excavation</u>					
A	Excavation for Goal post sockets diameter 150mm wide average depth not exceeding 1500 mm from formed level.	CM	2		
<u>Disposal</u>					
B	Load, wheel and cart away surplus excavated material to a Local Authority designated dumping site or fill soil heaps as away from site instructed by the Project Engineer.	CM	2		
<u>In- situ vibrated reinforced concrete Class 25 (20mm aggregates): in:</u>					
C	Socket - bases & stud columns	CM	2		
<u>Ribbed reinforcement steel bars to BS4449: 2005: Grade 500 high tensile strength including bends, hooks, tying wire and distance blocks; to S.E's detail (Provisional)</u>					
D	Assorted reinforcement	KG	200		
<u>Formwork</u>					
E	Sawn formwork with one coat of an approved retarding agent to vertical sides of socket bases	SM	8		
<u>Mild steel work in:-</u>					
F	Achoring system anchoring in concrete including neoprene caps all as per manufacturer's instructions.	NO	4		
G	150mm Diameter x 4mm thick CHS sockets all removable.	LM	30		
<u>Prime stop and apply one undercoat and two finishing coats of gloss paint to CROWN PAINTS first quality or other equal and approved to metal surfaces of:</u>					
H	General metal surfaces	LM	60		
<u>Goal net and ring</u>					
I	Standard goal net and ring all to approval welded to steel post.	NO.	2		
J	25mm thick fibre glass block board all fixed to approval	SM	4		
K	Supply and fix 100mm thick polyethylene foam padding	SM	4		
L	Supply and fix 25mm thick rubber tubing all around 150mm diameter vertical posts	LM	6		
<u>TOTAL FOR GOAL POSTS CARRIED TO SUMMARY</u>					

ITEM	DESCRIPTION	UNIT	QTY	RATE	AMOUNT
SUMMARY FOR BILL NO. 08 BASKET BALL PITCH					
ELEMENT					
1	EXCAVATIONS		BP/1		
2	BASKET BALL COURT		BP/2		
3	WATER DRAINAGE AROUND PITCH		BP/4		
4	BASKET GOAL POSTS		BP/5		
TOTAL FOR BASKET BALL PITCH CARRIED FORWARD TO GRAND SUMMARY					

BOUNDARY WALL

ITEM	DESCRIPTION	UNIT	QTY	RATE	AMOUNT
	<p><u>BOUNDARY WALL</u></p> <p><u>ELEMENT NO.1</u></p> <p><u>SUBSTRUCTURES</u></p> <p><u>(ALL PROVISIONAL)</u></p> <p><u>Siteworks and Excavations</u></p>				
A	Clear site of all grass, hedges, shrubs, bushes including grubbing up of roots, cart away arising debris and burn them.	SM	500		
	<u>Excavations</u>				
B	Excavate for Strip foundations depth not exceeding 1.50 metres starting groundlevel	CM	252		
C	Ditto to column base	CM	396		
D	Extra over excavation for excavating in soft rock	CM	6		
E	Allow for keeping the whole of the excavations free from all water; include for draining or other wise keeping all works free from water as necessary over the entire contract period			ITEM	
F	Allow for maintaining and upholding sides of excavations and keeping excavations clear of all fallen materials, rubbish etc			ITEM	
	Carried to Collection				

ITEM	DESCRIPTION	UNIT	QTY	RATE	AMOUNT
	<u>SUBSTRUCTURES-(CONTINUED)</u>				
	Disposal of excavated materials				
A	Return, fill and ram selected excavated material around foundations.	CM	366		
B	Load,wheel and cart away surplus excavated material away from site	CM	282		
	Insitu class 15 / 20 mm aggregates as described in:				
C	50mm Thick blinding to strip foundation	SM	168		
D	Ditto to column bases	SM	183		
	Insitu concrete class 20 (20mm maximum aggregate size):vibrated and reinforced:				
E	Strip footing	CM	34		
F	Ditto to column bases	CM	55		
G	Columns	CM	25		
H	Ground Beam	CM	14		
	Carried to Collection				

ITEM	DESCRIPTION	UNIT	QTY	RATE	AMOUNT
	<u>SUBSTRUCTURES-(CONTINUED)</u>				
	Modular steel frame with 5mm thick steel plates covering formwork and/or marine board formwork: to:				
A	Sides of stripfooting	SM	385		
B	Ditto ground beam	SM	135		
	Ribbed reinforcement bars to BS 4449:2005 , Grade 500 high tensile strength, Including all necessary bends, hooks, tying wires and distance blocks (Provisional):				
C	8mm diameter	KG	1953		
D	10 mm ditto	KG	1241		
E	12 mm ditto	KG	3009		
F	16 mm Ditto	KG	5896		
	Foundation Wall				
	Natural quarry stones rough dressed with a minimum compressive strength of 7.0N/mm² average compressive strength to BS 5390;bedded and jointed in cement and sand(1:4) mortar;reinforced with 25 x 3mm thick iron strips at alternate courses.				
G	200mm Thick walling	SM	750		
	Carried to Collection				

ITEM	DESCRIPTION	UNIT	QTY	RATE	AMOUNT
	<u>COLLECTION</u> FROM PAGE BW/1 FROM PAGE BW/2 FROM PAGE BW/3				
	TOTAL FOR ELEMENT NO. 1 CARRIED TO (SUBSTRUCTURES) SUMMARY	KSHS			

ITEM	DESCRIPTION	UNIT	QTY	RATE	AMOUNT
	<u>ELEMENT NO. 2</u>				
	<u>REINFORCED CONCRETE SUPERSTRUCTURE</u>				
	Insitu concrete class 20 (20mm maximum aggregate size):vibrated and reinforced:				
A	Columns	CM	53		
	Modular steel frame with 5mm thick steel plates covering formwork and/or marine board formwork: to:				
B	Vertical sides of columns	SM	616		
	<u>Steel reinforcement as described including cutting to length, bending, hoisting and fixing including all necessary tying wires and spacing blocks (all provisional)</u>				
C	12mm diameter ditto	KG	2,149		
D	8mm diameter ditto	KG	1434		
	TOTAL FOR ELEMENT NO. 2 CARRIED TO				
	(REINFORCED CONCRETE) SUMMARY				

ITEM	DESCRIPTION	UNIT	QTY	RATE	AMOUNT
	<p><u>ELEMENT NO. 3</u></p> <p><u>WALLING</u></p> <p><u>Smooth chisel dressed natural stone walling in cement and sand (1:4) mortar reinforced with and including 25 x 3mm thick hoop iron in every alternate course</u></p>				
A	200mm Thick walling	SM	1200		
B	<p>Precast concrete class 20/20 coping as described in;</p> <p>450 x 450 x 50 mm thick column capping, four times weathered and throated, bedded and jointed in cement and sand(1:4) mortar</p>	NO	183		
C	250mm wide x 50 mm thick wall coping twice weathered and throated, bedded and jointed in cement and sand mortar (1:4) on stone walling (m.s.)	LM	500		
	TOTAL FOR ELEMENT NO. 3 CARRIED TO (WALLING) SUMMARY				

ITEM	DESCRIPTION	UNIT	QTY	RATE	AMOUNT
	<u>ELEMENT NO. 4</u>				
	<u>EXTERNAL FINISHES</u>				
A	Extra over walling for smooth chisel dressing with flush pointed vertical joints and recessed horizontal joints 10 mm rod in cement and sand mix (1:3) mortar including one coat of Bituminous paint	SM	2400		
	<u>12mm (minimum) two coat lime plaster complete with wire gauze anti-crack mechanism at the intersection of masonry walling and concrete beams as described to:-</u>				
B	Columns	SM	616		
C	Ground beam	SM	135		
	GATES				
	Mild steel sections as described in;				
D	6000mm wide x 2400mm high double gate comprising of 50x50x3mm RHS framing and middle rail 50x25x3mm RHS Vertical infill members at 225mm centres; priming with red oxide primer; purpose made ironmongery; all necessary lugs and grouting as per details (all with roller at the ground)	NO	1		
E	Ditto pedestrian gate size 900x1800 ditto	NO	1		
	<u>Prepare surfaces and apply two coats of first grade quality of gloss oil paint as manufactured by Crown Solo Paints or equal and approved on;</u>				
F	General surfaces of metal	SM	33		
	TOTAL FOR ELEMENT NO. 4 CARRIED TO				
	(EXTERNAL FINISHES) SUMMARY				

ITEM	DESCRIPTION				AMOUNT
	<u>SECTION SUMMARY - BOUNDARY WALL</u>				
1	SUBSTRUCTURES FROM PAGE.....	BW/4			
2	R.C. SUPERSTRUCTURE FROM PAGE.....	BW/5			
3	WALLING FROM PAGE.....	BW/6			
4	EXTERNAL FINISHES FROM PAGE.....	BW/7			
	TOTAL FOR BOUNDARY WALL CARRIED TO GRAND SUMMARY				

CIVIL WORKS - ROADS

CIVIL WORKS					
BILL № 1: Preliminary and General Items					
ITEM	DESCRIPTION	UNIT	QTY	RATE	AMOUNT
1.01	Allow Provisional sum of Kenya shillings (KSh 500,000/=) for materials testing as instructed by the Engineer.	Prov. Sum	1	500,000.00	500,000.00
1.02	Extra Over on Item 1.01 for Contractors overheads and profits	%			
1.03	Allow a Prime Cost (P.C) sum of Kenya Shillings One Million (KShs. 1,000,000) for training of Engineers, Technicians and other support staff as maybe instructed by the Engineer.	PC Sum	1	1,000,000.00	1,000,000.00
1.04	Extra Over on Item 1.03 above for the Contractors overheads and profits	%			
BILL 1 TOTAL CARRIED TO SUMMARY PAGE					

BILL № 2: Site Clearance and Topsoil Stripping					
ITEM	DESCRIPTION	UNIT	QTY	RATE	AMOUNT
2.01	Clear site including removal of trees (girth less than 300 mm), hedges, bushes and other vegetation and other deleterious materials, grub up roots and backfilling of holes left by removal of stumps and roots in accordance with the Specifications, as shown on the drawings and as instructed by Engineer.	m2	2200.00		
2.02	Removal of top soil to a maximum depth of 200 mm including excavation, loading and disposal	m3	440.00		
2.03	Cutting of trees of all girth above 300 mm including cutting of trunks, branches, uprooting and removal of all materials and stacking within the Right of Way and complete with filling of depressions/pits by earth including liaison with concerned authorities for obtaining permissions.				
	(i) Girth from 300 mm to 600 mm	№	8		
	(ii) Girth above 600 mm but up to 900 mm	№	5		
	(iii) Girth above 900 mm but up to 1800 mm	№	3		
2.04	Transportation of the existing trees of girth above 600 mm girth as instructed by Engineer, including shifting of the tree and storing at locations as instructed by the Engineer.	№	8		
Total of Bill № 2(Carried Forward to Summary					

BILL № 3: Earthworks					
ITEM	DESCRIPTION	UNIT	QTY	RATE	AMOUNT
	No separate payments shall be made for the overhaul of the material and the cost of such haulage shall be included in the rates and or prices.				
3.01	Cut to spoil in soft material	m3	1,150		
3.02	As Item 5.01 but in hard material	m3	345		
3.03	Provide, spread, water, process and compact 300 mm improved subgrade to 100% MDD (AASHTO T99) in two layers of 150 mm thickness.	m3	1,062		
3.04	Provide and compact soft material as fill material as shown in the drawing and as directed by the Engineer	m3	2,078		
3.05	Provide and fill in hard material as shown in the drawing and as directed by the Engineer.	m3	416		
3.06	Provide, Spread and compact rockfill in swampy areas	m3	50		
	Total of Bill № 3 (Carried Forward to Summary)				

BILL № 4: Culvert and Drainage Works					
ITEM	DESCRIPTION	UNIT	QTY	RATE	AMOUNT
	No separate payment shall be made for the haulage of surplus or unsuitable excavated material and the cost of such haulage shall be included in the rates and/or prices				
4.01	Excavate in soft material for pipe culverts, subsoil drains, headwalls, wing walls, aprons, toe walls, drop inlets, mitre drains, catch water drains and median drains including support of trench sides, backfilling and compacting as specified or as instructed by the Engineer.	m3	576		
4.02	As Item 8.01 but in hard material (any method)	m3	173		
4.03	Allow for hacking in existing concrete drain for junction connections	m3	10		
4.04	Allow for perforation and connecting to the existing drain including stoppage of inflowing water (hole approximately 600 wide x 800 high x 250 thick)	no.	2		
4.05	Excavate/ desilt, grade to shape inlets outfalls, side drains to free flow conditons including cart to spoil any excess grass debris and soils as and where directed by the Engineer.	m3	50		

4.06	Provide, lay and joint 450 mm Internal Diameter (I. D.) Reinforced Cement Concrete pipes. The rate to include backfilling and compaction to drain formation level	m	110		
4.07	Ditto item 8.06 above but 600mm I.D. Reinforced Cement Concrete pipes	m	24		
4.08	Provide place and compact class 25/20 concrete to headwalls, wingwalls, aprons and toe walls to pipe culverts.	m ³	20		
4.09	Provide place and compact 150mm class 15/20 concrete to beds and surround to 450mm diameter pipes (0.4059m ³ /m)	m ³	45		
4.10	Ditto item 8.11 above but 600mm I.D. Reinforced Cement Concrete pipes (0.5259m ³ /m)	m ³	13		
4.11	Allow for in-situ lining with concrete Class 20/20 on outfall drains through built-up areas and limit of works areas and access roads	m ³	10		
4.12	Provide and joint 600mm diameter precast concrete invert block drain (IBD) channels with two double side precast side slabs of 600x225x75mm as lining for side drain including bedding and backfilling with selected material as directed by the Engineer.	m	480		
4.13	Extra Over for precast side slabs of 600x225x75mm.	m	960		
4.14	Provide all materials lay and joint shallow IBD as directed by the Engineer to form mitre drains. Rate to include provision of 100mm well compacted bed and jointed by 1:3 cement mortar	m	500		
4.15	Provide and lay 150mm thick grouted stone pitching with ratio 1:4 cement to Mortar, on culvert inlets and outlets and where directed by the Engineer.	m ²	40		
4.16	Provide all materials and construct standard untrapped gully pot in concrete class 20/20 reinforced with BRC A142 and with 350x500mm polyresin frames and covers conforming with standard specifications	no.	9		
4.17	Provide and place A142 fabric Mesh reinforcement or equivalent for wing walls, head walls, aprons, toe, inlets and outlets as directed by the Engineer	m ²	40		

4.18	Excavate in soft material for service ducts including support of trench sides, backfilling and compacting as specified or as instructed by the Engineer.	m3	35		
4.19	As Item 8.20 but in hard material (any method)	m3	14		
4.20	Provide and lay 450 Dia service ducts of length 10 m each as per the drawings and as instructed by the Engineer	No.	2		
Total of Bill № 4 (Carried Forward to Summary)					

BILL № 5: Natural Material for Sub-base and Base					
ITEM	DESCRIPTION	UNIT	QTY	RATE (KShs)	AMOUNT (KShs)
	Measurements and payment by method 'A' as defined in the standard specifications. No separate payments shall be made for the overhaul of material and the cost of such haulage shall be included in the rates and or prices				
5.01	Provide, place, water and compact Natural Gravel Material to 95% MDD (AASHTO T180) of sub base quality for base for the walkways of thickness 150mm and on the carriageway and parking to a consolidated thickness of not more than 300mm as shown in the drawings and as instructed by the Engineer	m3	950.00		
5.02	Prepare surface provide, place, handpack (200mm in one layer)and compact quarry chips (natural blue stone) to refusal densities on the carriageway and parking as directed by the Engineer.	m3	550.00		
Total of Bill № 5 (Carried Forward to Summary)					

BILL № 6: Concrete Works					
ITEM	DESCRIPTION	UNIT	QTY	RATE (KSH)	AMOUNT (KSH)
6	CONCRETE				
6.01	Provide and fix on the carriageway and parking interlocking concrete paved unishaped blocks (monolithic single layer precast concrete blocks) of any specified colour/size & shape, with approved pattern of 80 mm thick having average crushing strength of 50 N/mm ² on average thickness of 50 mm complete with uniformly graded river sand cushioning properly compacted with a mechanical compactor to required level, grade and camber as instructed by Engineer. Rate to include bedding sand and that to fill the joints, ties and edge restraints	m ²	2,200		
6.01B	Extra over item 17.01 for laying blocks at speed bumps	m ²	33		
6.02	Ditto item 17.01 above but for 60mm heavy duty blocks at the walkway	m ²	2,208		
6.03	Provide, lay in place and joint 600x600x50mm well cured paving slabs on 50mm well compacted sand/quarry dust bed to footpaths/islands and around the blocks as stipulated in the special Specifications.	m ²	100		
BILL 6 TOTAL CARRIED TO SUMMARY PAGE					

BILL № 7: Road Furniture					
ITEM	DESCRIPTION	UNIT	QTY	RATE	AMOUNT
7A	Road Marking and Road Signs				
	Road Marking				
7A.01	Provide and lay hot applied thermoplastic road marking compound in approved colour and shade (ASTM 9) for road marking on bituminous surface on centerline, 100 mm, edge line 150 mm wide 3.0 mm thick, using fully automatic extrusion machine and using pre-melter for melting thermoplastic material including cleaning the surface of all dirt, dust, and other foreign matter, complete with demarcation at site/pre-marking, finishing and managing the traffic movements. Marking to be done as per the specifications, detailed drawings and as instructed by the Engineer.				
	(i) For lane marking (broken lines) with white paint, 100 mm wide	m2	96		
	(ii) For lane marking with yellow paint, 100mm wide	m2	990		
	(iii) For raised kerb lines with black paint, 150 mm wide	m2	144		
70A.02	Provide and lay hot applied thermoplastic road marking compound in approved colour and shade (ASTM 9) for road marking on bituminous road surface on pedestrian crossings, chevrons, directional arrows, give way and stop lines mm thick using fully automatic extrusion machine and using pre-melter for melting thermoplastic. Material, including dispensing drop on glass beads of approved make and as per BS 6088 at the rate of 250g/m ² including cleaning the surface of all dirt, dust, and other foreign matter, complete with demarcation at site/ pre-marking, finishing and managing the traffic control. Marking to be done as per the specifications, drawings and as instructed by the Engineer.	m2	300		
7B	Other Road Furniture				
7B.01	Provide, lay and Joint complete with hauncing as shown on the drawings and as instructed by the Engineer				
	(i) Raised Kerbs	m	960		
	(ii) Flush Kerbs	m	100		
7B.02	Provide, lay and Joint complete with hauncing as shown on the drawings and as instructed by the Engineer 100 x 125 mm channels for the walkways and shallow drains	m	4,728		
	Total of Bill № 7 (Carried Forward to Summary				

SUMMARY OF CIVIL WORKS

Bill No.	DESCRIPTION	AMOUNT KSHS.
1	Preliminary and General Items	
2	Site Clearance and Topsoil Stripping	
3	Earthworks	
4	Culverts and Drainage Works	
5	Natural Material for Sub-base and Base	
6	Concrete Works	
7	Road Furniture	
8	Landscaping and Environmental Mitigation Measures	
A	Sub-total A	

CIVIL WORKS - SEWER

BILL NO. 1.1 - PRELIMINARIES AND GENERAL ITEMS					
Item No	Description	Unit	Quantity	Rate (KSh.)	Amount (KSh.)
CLASS A - GENERAL ITEMS					
Contractual Requirements					
A140.1	Provide for preparation and submission to the employer 1No set of virograph and 2No sets of blue print copies (A1 SIZE) of as built drawings for all the sewer pipelines in the contract. Note that manhole positions in the layout should be actual (geo-referenced to the national grid).	sum	1		
Specified Requirements					
Testing of Materials and Works					
A250	Provide for concrete strength test. Rate to include for casting of the necessary number of cubes, curing,transport from site to testing institution and fees payable for the service.	nr	20		
A250.1	Provide for testing of the sewer pipes.Rate to include for transportation to the testing institutions and fees payable for this service.	nr	10		
Temporary Works					
A272	Traffic regulation (including signages,warning tapes and warning signs); establishment, operation and removal.	Item	1		
Bill No. 1.1- PAGE 1 TOTAL CARRIED TO SEWER SUMMARRY					

BILL No. 1.2 MEASURED WORKS					
ITEM No.	DESCRIPTION	Unit	Qty	Rate	Amount (Kshs.)
	<p>The rates quoted by the Contractor shall be deemed to include provision by the Contractor to provide temporary vehicular access to all construction sites including negotiating with private land owners and paying the necessary charges as required.</p> <p>CLASS A - GENERAL ITEMS</p> <p>GENERAL CLEARANCE</p>				
A140.3	Allow for setting out of the works	m	710.00		
	<p>Testing of the works</p>				
A260	Carrying out test on sewer, a pipeline as specified or directed by the engineer, include provision of all equipment and materials	m	710.00		
A277	Allow for keeping trenches and other excavation free of water which may have entered through ground seepage, rain or by other means as directed by the Engineer	sum	1.00		
	<p>CLASS B - SITE INVESTIGATION</p>				
B111	Trial holes where ordered to prove location , construction size etc., of pipelines, services or existing structures, max depth n.e 1m (provisional)	nr	3.00		
B112	Trial holes where ordered to prove location , construction size etc., of pipelines, services or existing structures, max depth 1- 2m (provisional)	nr	3.00		
B113	Trial holes where ordered to prove location , construction size etc., of pipelines, services or existing structures, max depth 2-3m (provisional)	nr	3.00		
	<p>CLASS D - DEMOLITION AND SITE CLEARANCE</p> <p>The rate quoted is for site clearance and demolition along construction wayleave shall be deemed to include removal of the material and carting away to tips, identified by the Contractor in liaison with the Local Authority.</p>				
D100	General site clearance through undeveloped land over the wayleave, include for additional clearance required	ha	0.21		
D210	Removal of trees girth 0.5- 1m (Provisional)	nr	5.00		
D220	Removal of trees girth 1-2m (Provisional)	nr	1.00		
Bill No. 1.2- PAGE 2 TOTAL CARRIED FORWARD TO COLLECTION SHEET					

ITEM No.	DESCRIPTION	Unit	Qty	Rate	Amount (Kshs.)
	CLASS I - PIPEWORK - PIPES				
	Supply of pipes				
I230.1	Nominal bore 150mm uPVC Class 34 Pipeline	m	500.00		
I230.2	Nominal bore 225mm uPVC Class 34 Pipeline	m	10.00		
I230.3	Nominal bore 300 mm DWC HDPE SN8 Pipe	m	200.00		
	uPVC & DWC HDPE SN8 PIPES TO BS 5911 WITH SPIGOT AND SOCKET				
	The rates entered against the items in this section shall include for stripping top soil, laying aside and subsequently replacing over refilled trench, excavation in trench in material other than rock, shuttering where necessary, refilling and compacting spreading surplus soil evenly over and alongside pipe trench, compacting, lay and joint pipes to correct line and level. Depths are stated from ground level to invert level.				
	Nominal bore 150 mm in trenches				
I233.1	depth not exceeding 1.5 m.	m	500.00		
	Nominal bore 225 mm in trenches				
I232.1	depth not exceeding 1.5 m.	m	10.00		
	Nominal bore 300 mm in trenches				
I232.1	depth not exceeding 1.5 m.	m	40.00		
I233.1	ditto but depth; 1.5 - 2.0 m.	m	100.00		
I234.1	ditto but depth; 2.0 - 2.5 m.	m	40.00		
I235.1	ditto but depth; 2.5 - 3.0 m.	m	20.00		
Bill No. 1.2- PAGE 3 TOTAL CARRIED FORWARD TO COLLECTION SHEET					

ITEM No.	DESCRIPTION	Unit	Qty	Rate	Amount (Kshs.)
	CLASS K - PIPEWORK - MANHOLES AND PIPEWORK ANCILLARIES				
	Excavation quantities are given net. The rate entered are to include for manhole concrete slabs and covers, step irons or ladder, excavation, shuttering where necessary, refilling and compacting around the finished manholes, and disposing of surplus spoil is to be evenly spread. Excavation in any material other than rock				
	Masonry manhole 1050 mm , reinforced concrete manhole slab and cover.				
K151.1	depth not exceeding 0.6 m.	nr	35.00		
K151.2	depth not exceeding 0.9 m.	nr	15.00		
	MANHOLES				
	Manhole size 1050 mm , reinforced concrete manhole slab and cover.				
K151.1	depth not exceeding 1.5 m.	nr	2.00		
	MANHOLES				
	Manhole size 1200 mm , reinforced concrete manhole slab and cover.				
K152.1	ditto but depth; 1.5 - 2.0 m.	nr	4.00		
K153.1	ditto but depth; 2.0 - 2.5 m.	nr	3.00		
K154.1	ditto but depth; 2.5 - 3.0 m.	nr	1.00		
Bill No. 1.2- PAGE 4 TOTAL CARRIED FORWARD TO COLLECTION SHEET					

ITEM No.	DESCRIPTION	Unit	Qty	Rate	Amount (Kshs.)
	CLASS L; SUPPORTS AND PROTECTION ANCILLIARIES TO LAYING AND EXCAVATION Extras to Excavation and backfilling Trenches (Note : blasting not allowed for any rock excavation) <i>In pipe trenches 225mm bore</i>				
L111	<i>In pipe trenches 300mm bore</i> Excavation of rock	m3	2.50		
L111	<i>In pipe trenches 450 mm bore</i> Excavation of rock	m3	60.00		
L 121	<i>In Manholes and other chambers</i> <i>(Note: Blasting not allowed for any rock excavation)</i> Excavation of rock	m3	7		
L 128	Allow for excavation of soft material below final surface of manhole and back fill with approved hardcore, well compacted in ,layers of 200mm thickness , depth not exceeding 1.0m	m3	16		
Bill No. 1.2- PAGE 5 TOTAL CARRIED FORWARD TO COLLECTION SHEET					

ITEM No.	DESCRIPTION	Unit	Qty	Rate	Amount (Kshs.)
	Bed, Haunches and Surrounds				
	<i>Mass concrete grade 15/20 in 150mm Thick Beds, Haunches and surrounds</i>				
L 444.2	225 mm nominal bore pipeline Bed haunch and surround type D (0.2821 m ³)	m	10.00		
L 444.3	300 mm nominal bore pipeline Bed haunch and surround type A (0.1471 m ³)	m	160.00		
L 444.5	300 mm nominal bore pipeline Bed haunch and surround type D (0.3702 m ³)	m	40.00		
Bill No. 1.2- PAGE 6 TOTAL CARRIED FORWARD TO COLLECTION SHEET					

COLLECTION PAGE					
ITEM No.	DESCRIPTION	Unit	Qty	Rate	Amount
	COLLECTION PAGE				
1	From Page 2				
2	From Page 3				
3	From Page 4				
4	From Page 5				
5	From Page 6				
	Sub-Total (i)				
Bill No. 1.2-TOTAL CARRIED FORWARD TO SEWER SUMMARY					
ITEM No.	DESCRIPTION	Unit	Qty	Rate	Amount
	BILL NO 1.3 BIODIGESTER				
A	Provide a provisional sum of Kenya Shillings Five Million (Kshs 5,000,000.00) only for the builders works for a concrete biodigester inclusive of waste water treatment plant to be executed as authorized by the Engineer and to be measured and valued by the Quantity Surveyor in accordance with the Contract	PC Sum	1		
B	Provide a PC sum of Kenya Shillings Five Million (Ksh 5,000,000) only for mechanical installations associated with the Biodigester to be executed as authorized by the Engineer	PC Sum	1		
Bill No. 1.3- PAGE 3 TOTAL CARRIED FORWARD TO GRAND SUMMARY					

SEWER SUMMARY

Bill No.	Description	Amount (KSh.)
Bill No. 1.1	Preliminaries and General Items	
Bill No. 1.2	Measured Works	
Bill No. 1.2	Biodigester	
	TOTAL FOR SEWER CARRIED TO GRAND SUMMARY	

STUDENT'S CENTRE

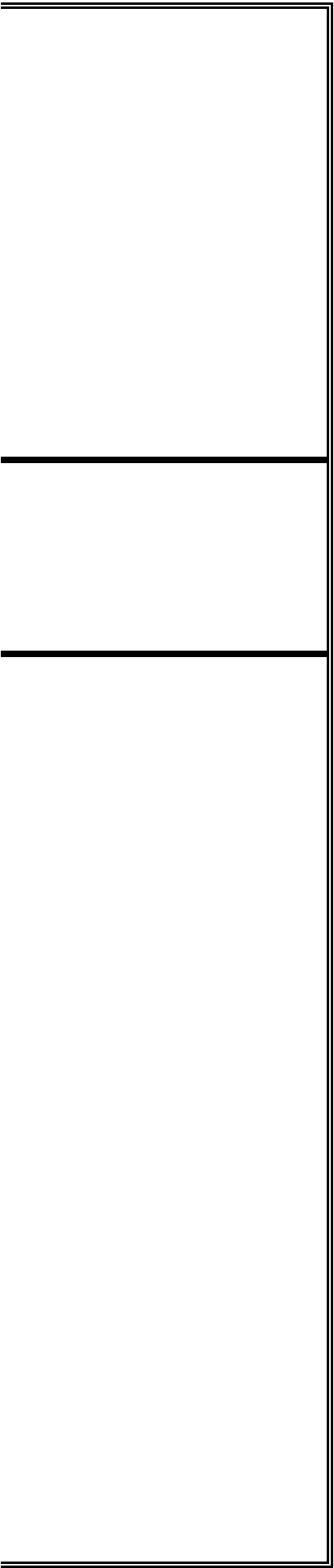

||

ITEM	DESCRIPTION	UNIT	QTY	RATE	AMOUNT
<u>PROPOSED STUDENT'S CENTRE FOR STUDENT HOUSING PROGRAM (STUDENT CENTRE)</u>					
BILL NO.1-BUILDERS WORKS					
ELEMENT NO 1 - SUBSTRUCTURES (ALL PROVISIONAL)					
<i>Site Clearance</i>					
A	Clear site of all grass, hedges, shrubs, bushes grub up roots, load and remove from site and dispose at designated local authority areas.	SM	792		
B	Excavate average 200mm deep to remove top vegetable soil, load, remove from site and dump in designated local authority dump site.	SM	792		
C	Excavate to reduced levels in varying depths not exceeding 1.5m deep from existing ground levels.	Cm	277		
D	Excavate for Strip foundations depth not exceeding 1.50 metres starting from Reduced ground levels.	Cm	290		
E	Excavate for column bases depth not exceeding 1.5m starting from reduced Levels	Cm	189		
F	Extra over all type of excavation for excavating in soft rock	Cm	144		
Disposal of water					
G	Allow for keeping the whole of the excavation free from all spring and running water by pumping or any other such means as may be necessary	Item	1		
Planking and strutting					
H	Allow for maintaining and upholding the sides of excavations and keeping excavations clear of all fallen materials, rubbish etc	Item	1		
Carried to collection					

ITEM	DESCRIPTION	UNIT	QTY	RATE	AMOUNT
	<u>Disposal of excavated material</u>				
A	Return, fill and ram selected excavated material around foundations.	CM	227		
B	Load, wheel and cart away surplus excavated material to a Local Authority designated dumping site or fill soil heaps as away from site instructed by the Project Engineer.	CM	634		
	Fillings				
C	300mm thick hardcore bed: hand packed : compacted in layers not exceeding 150mm thick: to the satisfaction of the Structural Engineer	SM	792		
D	50 mm Thick Murram Blinding to surfaces of hadcore	SM	792		
	Anti - termite to treatment				
F	Approved anti-termite treatment, with ten-year guarantee, sprayed to surfaces of hardcore strictly in accordance with manufacturer's instructions.	SM	792		
	Damp-proof membrane				
G	1000 gauge polythene or other equal and approved damp-proof membrane, laid over blinded hardcore (measured separately) with 300mm side and end laps (measured nett-allow for laps); 1 No. layer: bedded in and including cement and sand (1:3) mortar	SM	792		
	Concrete Blinding				
	In situ concrete class 15/20 mm aggregates: vibrated:				
H	50 mm Thick under column bases	SM	157		
J	50 mm Thick under strip foundation	SM	264		
	In- situ vibrated reinforced concrete Class 25 (20mm aggregates): in:				
K	Column bases	CM	41		
L	Columns	CM	8		
M	Strip foundation	CM	53		
N	100mm thick surface bed	SM	792		
	Carried to collection				

ITEM	DESCRIPTION	UNIT	QTY	RATE	AMOUNT
	Ribbed reinforcement steel bars to BS4449: 2005: Grade 500 high tensile strength including bends, hooks, tying wire and distance blocks; to S.E's detail (Provisional)				
A	Assorted reinforcement	Kg	9,020		
	Mesh fabric reinforcement to BS 4483 BRC A142;200 x 200mm, weighing 2.22kg/m² (measured net - no allowance) for laps; in two layers - top & bottom; including bends, tying wire and spacer blocks)				
B	In floor beds. <i>Modular steel frame with 5mm thick steel plates covering formwork and/or marine board formwork: to:</i>	SM	792		
C	Vertical sides of columns	SM	125		
D	Edge of slab not exceeding 150mm girth	LM	115		
	Foundation Walling				
	Natural quarry stones rough dressed; bedded in and including cement and sand (1:4) mortar; reinforced with and including 45 mm wide hoop iron gauge in alternate courses: in:				
E	200mm thick walls in foundations	SM	615		
	<u>Pavings</u>				
F	Supply and lay 600 x 600mm medium duty paving blocks round the Building including laying, spreading and compacting 100mm thick approved sand bed blinding to approval.	SM	70		
	<u>Plinth</u>				
	<u>25mm Thick cement and sand (1:4) rendering on concrete or masonry ; wood float finished; to</u>				
G	Plinths externally	SM	69		
	Two coats black bitumastic paint on:				
H	Rendered surfaces	SM	69		
	Carried to collection				

ITEM	DESCRIPTION	UNIT	QTY	RATE	AMOUNT
	COLLECTION				
	Total brought forward from page no:		SC/1		
	Total brought forward from page no:		SC/2		
	Total brought forward from page no:		SC/3		
	ELEMENT NO. 1				
	SUBSTRUCTURES				
	Carried to Main summary				

ITEM	DESCRIPTION	UNIT	QTY	RATE	AMOUNT
<u>PROPOSED STUDENT'S CENTRE FOR STUDENT HOUSING PROGRAM (STUDENT CENTRE)</u>					
BILL NO.1-BUILDERS WORKS					
ELEMENT No 2 - R.C FRAME					
<i>In situ concrete class 25 (20 mm aggregate): vibrated: reinforced</i>					
A	Columns	CM	32		
B	Beams	CM	79		
D	150mm thick suspended slab	SM	458		
E	150 mm thick landing	SM	4		
F	Staircases	CM	1		
Ribbed reinforcement steel bars to BS4449: 2005:Grade 500 high tensile strength including bends, hooks, tying wire and distance blocks to S.E's detail (All provisional)					
G	Assorted reinforcement	Kg	35,164		
<i>Modular steel frame with 5mm thick steel plates covering formwork and/or marine board formwork: to</i>					
H	Sides of columns	Sm	485		
J	Sides and soffits of beams	Sm	790		
K	Soffits of suspended solid slabs	Sm	458		
L	Edges of slab over 150mm but not exceeding 225mm girth	Lm	115		
M	Sloping soffits of staircases	SM	6		
N	Soffits of landings	SM	4		
P	Riser of steps over 150 mm but not exceeding 225 mm girth	LM	16		
Q	Staircase string 300mm extreme girth and cut to profile of steps	LM	9		
R	Edges of landing over 150 but not exceeding 225mm high	Lm	8		
<u>ELEMENT NO. 2</u>		Carried to			
<u>R.C FRAME</u>		Main summary			

ITEM	DESCRIPTION	UNIT	QTY	RATE	AMOUNT
<p align="center"><u>PROPOSED STUDENT'S CENTRE FOR STUDENT HOUSING PROGRAM (STUDENT CENTRE)</u></p> <p align="center">BILL NO.1-BUILDERS WORKS</p> <p>ELEMENT No 3-WALLING</p> <p><u>WALLING</u></p> <p><u>External Walling</u></p> <p><i>Machine cut quarry stone walling with a minimum of 7.0 N/mm² average compressive strength to B.S 5390;bedded and jointed in cement and sand (1:4) mortar, reinforced with and including 25 x 3 mm thick hoop iron strips at every alternate course as described in;</i></p> <p>A 200mm thick walling Externally Sm 493</p> <p><u>Internal Walling</u></p> <p><i>Machine cut quarry stone walling with a minimum of 7.0 N/mm² average compressive strength to B.S 5390;bedded and jointed in cement and sand (1:4) mortar, reinforced with and including 25 x 3 mm thick hoop iron strips at every alternate course as described in;</i></p> <p>B 200mm thick walling Internally Sm 225</p> <p>C 150mm thick walling Internally Sm 130</p> <p>D Approved hessian based damp proof course to 200mm thick walling in cement/sand mortar Lm 364</p>					
<u>ELEMENT NO. 3</u>		Carried to			
<u>WALLING</u>		Main summary			

ITEM	DESCRIPTION	UNIT	QTY	RATE	AMOUNT
	<p align="center"><u>PROPOSED STUDENT'S CENTRE FOR STUDENT HOUSING PROGRAM (STUDENT CENTRE)</u></p> <p align="center">BILL NO.1-BUILDERS WORKS</p> <p>ELEMENT NO 4-WINDOWS</p> <p><u>MILD STEEL WINDOWS</u></p> <p>Supply, fabricate and fix the following purpose made mild steel casement windows to be fabricated from approved mild steel sections (atleast 14g 2mm thick) comprising of frame and casement incorporating permanent hooded high level ventilation panels infilled with mosquito gauze : window supplied complete with and including 12mm solid square burglar proofing bars fixed at 200mm centres both ways and metal fixing lugs including building into wall and making good, and all necessary iron mongery viz hinges, fasteners, and hasp including shop priming window with red oxide primer before delivery to site:-</p>				
A	Window, overall size 600 x 900mm high to Architects Details (WC/SH)	NO	14		
	<u>Glazing</u>				
B	4mm Thick obscure sheet glass panes over 0.1 but not exceeding 0.5 square meters; fixing with putty	SM	8		
	<u>Painting and Decorations</u>				
	<u>On Metal work</u>				
	<u>Prepare and apply aerosol spray painting in two finishing coats of first grade approved paint as described in</u>				
C	General window and grille surfaces; over 300mm girth internal	SM	16		
	<u>Bull-nosed burnt clay, finishing fair on all exposed surfaces and hoisting and placing in position, bedding, jointing and pointing in pigmented cement and sand (1:3) mortar</u>				
D	150 x 25mm thick clay window sill	LM	10		
	<u>ELEMENT NO. 4</u>				
	<u>WINDOWS</u>	Carried to the			
		Main summary			

ITEM	DESCRIPTION	UNIT	QTY	RATE	AMOUNT
	<p align="center"><u>PROPOSED STUDENT'S CENTRE FOR STUDENT HOUSING PROGRAM (STUDENT CENTRE)</u></p> <p align="center">BILL NO.1-BUILDERS WORKS</p> <p>ELEMENT NO 5-DOORS <u>Glazed mild steel casement doors</u></p> <p>Heavy gauge purpose made mild steel door comprising 40 x 25 x3mm stiles, top and bottom stiles, 4 No Intermediate rails, 1.5mm steel sheet both sides welded in place and 5mm thick clear glazing, all primed with red oxide and spray painted with 2 coats of first quality gloss oil paint; complete with hinges, stays, fasteners and necessary seremetals assembled and fixed to opening including cutting and pinning lugs to concrete or block work surround and bedding frame in cement and sand mortar (1:3).</p>				
A	Door overall size 900 x 2400mm high	NO	6		
B	Ditto Size 1500 x 2400mm high Doubleleaf door	NO	2		
	<u>Roller shutter door</u>				
C	Roller shutter door 1800 x 2400mm high ; comprising of 1800 x 2400 mm high roller shutter in 200mm wide gauge 18 mildsteel laths; galvanized iron pipe suspension system inclusive of vertical guide chanel, brackets and brackets in midsteel;2 no 650 x 2000 mm high fixed lights in 75 x 50 mm powder coated frames with all necessary iron mongery, painting all to architects details and approval.	No	12		
	Flush timber doors				
	50 mm thick Semi Solid cored flush doors with plywood facing to receive painting (m.s) all to Architects details, specifications and approval				
D	Door size 1000mm x 2060mm high comprising of 1 No opennable leaf size 900 x 2060mm high	NO	1		
E	Door size 800mm x 2400mm including fixed fanlight size 900 x 300mm high in 4mm clear glass (m.s)	NO	18		
	Carried to collection				

ITEM	DESCRIPTION	UNIT	QTY	RATE	AMOUNT
	<u>Frames and frame finishes in soft wood Timber</u>				
A	25 x 25mm quadrant	LM	97		
B	25 x 50mm architrave with two labours, plugged	LM	97		
C	150 x 50mm frame with three labours; chamfered edges; plugged	LM	97		
	<u>Painting and decorating</u>				
	<u>Priming back of frame with an aluminium or equivalent and approved wood primer</u>				
D	Surfaces not exceeding 100mm girth	LM	194		
E	Surfaces over 100mm but not exceeding 200mm girth	LM	97		
	<u>Prepare Knot, prime, stop and apply one undercoat and two coats first grade quality gloss oil paint to wood surfaces</u>				
F	General timber surfaces	SM	72		
G	Surfaces not exceeding 200mm girth	LM	97		
H	Surfaces over 100mm but not exceeding 200mm girth	LM	194		
	Ironmongery				
	Supply and fix the following ironmongery to timber complete with matching screws and keys to the approval of the Architect				
I	100mm pressed steel Butt Hinges	Pairs	29		
J	Stainless steel 2 Lever Door Lock with handle	NO	19		
K	Door fixing cramps	NO	114		
	Carried to Collection				
	COLLECTION				
	Total brought forward from page no:		SC/8		
	Total brought forward from page no:		SC/9		
	<u>ELEMENT NO. 5</u>	Carried to			
	<u>DOORS</u>	Main summary			

ITEM	DESCRIPTION	UNIT	QTY	RATE	AMOUNT
	PROPOSED STUDENT'S CENTRE FOR STUDENT HOUSING PROGRAM (STUDENT CENTRE)				
	ELEMENT NO. 7				
	ROOF CONSTRUCTION AND FINISHES				
	All members are first grade sawn celcured pressure impregnated cypress				
	The following 29 No. trusses spanning at various lengths at 1200mm c/c and 4.8m from ground level.				
	(All timber work is provisional)				
	Truss T1 (4 no.)				
A	150 x 50 truss rafters	LM	618		
B	150 x 50 mm King post	LM	133		
C	Ditto struts and ties	LM	1,188		
D	Ditto tie beam	LM	282		
E	100 x 50 wall plate.	LM	108		
F	Ditto purlins	LM	324		
	End of trusses				
	ROOF COVERING				
	<u>Prepainted 26 Gauge box profile galvanised steel sheet shaped as per architects approval or equally and approved</u>				
G	Ridge	LM	86		
H	Roof covering	SM	776		
	<u>In wrot cypress - prime grade</u>				
	250 x 25mm fascia board	LM	118		
J	100 x 20 mm T & G in eaves boarding on blandering	SM	35		
K	25 x 100 mm moulded cornice.	LM	234		
	Roof drainage				
	<u>26 Gauge galvanised steel sheet shaped as per architects approval or equally and approved</u>				
L	150 x 150 mm GI rain water gutter fixed to fascia board with mild steel brackets at 1.50 m centres.	LM	118		
M	Extra over ditto for stopped ends	No	6		
N	Extra over for 100mm diameter outlet	No	6		
P	100mm diameter down pipe fixed to walls with mild steel brackets at 1.50 m centres.	LM	30		
Q	Extra over ditto for swan neck offset.	No	6		
R	Ditto for splash shoe.	No	6		
S	12 mm diameter x 150 mm holding down bolt with head, nut and washers.	No.	48		
	Carried to Collection				

ITEM	DESCRIPTION	UNIT	QTY	RATE	AMOUNT
	Painting and decorating <u>Prepare and apply three coats of gloss paint to timber surfaces</u>				
A	Wood surfaces 200 - 300mm girth	LM	118		
	<u>Knot, prime, stop and apply one 3 coats of polyurethane varnish to:-</u>				
B	Wood general surfaces externally.	SM	35		
C	Surfaces of timber cornices, 0-100mm girth.	LM	234		
	Ceiling finishes Prepare and install 12mm thick Celotex ceiling or approved equivalent as per architects' details and approval.				
D		SM	761		
	Branding 50 x 50 mm timber branding spaced 600mm c/c as per architects details and approval				
E		LM	2,659		
	Carried to Collection				
	COLLECTION				
	Total brought forward from page no:		SC/8		
	Total brought forward from page no:		SC/9		
	ELEMENT NO. 6 Carried to				
	ROOF Main summary				

ITEM	DESCRIPTION	UNIT	QTY	RATE	AMOUNT
	<p align="center"><u>PROPOSED STUDENT'S CENTRE FOR STUDENT HOUSING PROGRAM (STUDENT CENTRE)</u></p> <p align="center">BILL NO.1-BUILDERS WORKS</p> <p>ELEMENT NO 7- EXTERNAL FINISHES</p> <p>EXTERNAL WALL FINISHES</p> <p><u>Cement and sand (1:3) render:wood floated: on concrete or blockwork: to</u></p>				
A	15mm thick beam, columns, slab moulds and walling externally	SM	97		
B	Extra over horizontal and vertical pointing in 10mm thick rod in cement and sand mix (1:3) mortar including one coat Bituminous paint	SM	518		
	<p>Painting</p> <p><u>Prepare and apply one coat undercoat and two finishing coats of long lasting exterior/ weatherguard paint or other equal and approved exterior quality paint to surfaces as described in:-</u></p>				
C	Concrete/masonry surfaces externally-Beam, Column and Slab Moulds	SM	97		
	<p><u>ELEMENT NO. 7</u> Carried to</p> <p>EXTERNAL FINISHES Main summary</p>				

ITEM	DESCRIPTION	UNIT	QTY	RATE	AMOUNT
<u>PROPOSED STUDENT'S CENTRE FOR STUDENT HOUSING PROGRAM (STUDENT CENTRE)</u>					
BILL NO.1-BUILDERS WORKS					
ELEMENT NO 8 - INTERNAL FINISHES					
<u>Internal Wall Finishes</u>					
<u>Cement and sand (1:4) backings</u>					
A	12mm thick to receive Wall tiles	SM	62		
<u>Ceramic wall tiles</u>					
<u>Allow a Prime Cost supply rate of Ksh. 1000 per SM</u>					
B	Supply and Fix 200x200x6mm thick ceramic wall tiles Saj Ceramics or equal and approved on prepared backings(m.s) with proprietary adhesive; jointed and pointed in matching coloured proprietary grouting: including pvc spacers and expansion joint as necessary: all to Architect's approval. - Wall Surfaces	SM	62		
<u>12mm (minimum) two coat lime plaster complete with wire gauze anti-crack mechanism at the intersection of masonry walling and concrete beams as described to:-</u>					
C	Concrete/masonry surfaces Internally	SM	1,253		
D	Ditto to door jambs externally and surfaces not exceeding 200mm girth	LM	97		
<u>Painting and Decoration</u>					
<u>Prepare and apply one undercoat and one finishing coat first quality permaplast emulsion paint manufactured by Crown Solo Paints or equal and approved paint on:-</u>					
E	Plastered concrete/masonry surfaces internally	SM	1,253		
F	Ditto to window cills, door Jambs Externally and Surfaces not exceeding 200mm girth	LM	97		
Carried to Collection					

ITEM	DESCRIPTION	UNIT	QTY	RATE	AMOUNT
	<u>Floor Finishes</u>				
A	<u>Cement and sand (1:3) screeds, backings, beds etc</u> 32mm bed finished to receive Floor Tiles (m.s)	SM	761		
	<u>Ceramic Floor tiles</u> <u>Allow a Prime Cost supply rate of Ksh. 1000 per SM</u>				
C	Supply and Fix 300 x 300x 10mm thick Ceramic tiles, Saj Ceramics or equal and approved; on prepared bed(m.s) with proprietary adhesive; jointed and pointed in matching coloured proprietary grouting: including pvc spacers and expansion joint as necessary: all to Architect's approval.	SM	675		
D	Ditto Non Slip Ceramic Tiles	SM	86		
E	Ditto 100mm wide Wall Skirtings	LM	240		
	<u>Staircase floor finishes</u>				
F	<u>Cement and sand (1:4) backings etc</u> 32mm bed finished to receive ceramic tiles to surfaces of Landings (m.s)	SM	4		
G	25 x 300 mm wide treads to receive ceramic tiles (m.s)	LM	48		
H	20 x 150mm risers to receive ceramic tiles (m.s)	LM	48		
	<u>Staircase floor finishes</u>				
J	Non Slip Ceramic Tiles to surfaces of Landings)	SM	4		
K	Non Slip Ceramic Tiles to 300 mm wide treads	LM	48		
L	Non Slip Ceramic Tiles to 150mm risers	LM	48		
	<u>Staircase soffit finishes</u>				
	<u>12mm (minimum) two coat lime plaster complete with wire gauze anti-crack mechanism at the intersection of masonry walling and concrete beams as described to:-</u>				
M	Soffits of staircase landing	SM	4		
N	Ditto to sloping soffites exceeding 15° from horizontal	SM	22		
O	Staircase string 300mm extreme girth and cut to profile of steps	LM	29		
	<u>Paint works</u>				
P	Soffits of staircase landing	SM	4		
Q	Ditto to sloping soffites exceeding 15° from horizontal	SM	22		
R	Staircase string 300mm extreme girth and cut to profile of steps	LM	29		
	Carried to Collection				

ITEM	DESCRIPTION	UNIT	QTY	RATE	AMOUNT
A	<u>Painting and Decoration</u> <u>Prepare and apply one undercoat and one finishing coat first quality plastic emulsion paint on:-</u> Ceiling surfaces	SM	761		
	Carried to Collection				

ITEM	DESCRIPTION	UNIT	QTY	RATE	AMOUNT
	COLLECTION				
	Total brought forward from page no:		CM/14		
	Total brought forward from page no:		CM/15		
	Total brought forward from page no:		CM/16		
	<u>ELEMENT NO. 8</u> Carried to				
	INTERNAL FINISHES				

ITEM	DESCRIPTION	UNIT	QTY	RATE	AMOUNT
A	<p align="center">PROPOSED STUDENT'S CENTRE FOR STUDENT HOUSING PROGRAM (STUDENT CENTRE)</p> <p align="center">BILL NO.1-BUILDERS WORKS</p> <p>ELEMENT NO 9- BALUSTRADING AND RAILING</p> <p><i>Balustrades and staircase railings</i></p> <p>1200mm high mild Steel balustrade; comprising 60 x 10mm mild Steel balusters at 900mm centres; bolted to base plate and tread (m.s)with 7No. 25mm diameter horizontal bars, and 75x4mm diameter CHS mild Steel handrail part welded into 60x10mm balustrades; to Architects drawings</p>	LM	7		
B	<p><i>Prepare, prime and apply one undercoat and two finishing coats first quality gloss oil paint on</i></p> <p>General metal surfaces of ballustrading (both sides measured overall)</p>	SM	8		
	<p><u>ELEMENT NO. 9</u> Carried to the <u>BALUSTRADING AND RAILING</u> Main summary</p>				

ITEM	DESCRIPTION	UNIT	QTY	RATE	AMOUNT
	<p>ELEMENT NO. 10</p> <p>PROVISIONAL SUMS</p> <p>A Allow a provisional sum of Kenya Shillings nine hundre Thousand (KSHS. 900,000) for electrical installation and connection works to the guard house per Engineers specification.</p> <p>B Allow a provisional sum of Kenya Shillings seve hundred Thousand (KSHS. 100,000) for mechanical installation and connection works to the guard house per Engineers specification.</p>	SUM	1		
	<p>ELEMENT NO.10</p> <p>PROVISIONAL SUMS</p>				

ITEM	DESCRIPTION	UNIT	QTY	RATE	AMOUNT
	<p style="text-align: center;"><u>PROPOSED STUDENT'S CENTRE FOR STUDENT HOUSING PROGRAM (STUDENT CENTRE)</u></p> <p style="text-align: center;">MAIN SUMMARY</p> <p>1 Substructures</p> <p>2 Reinforced Concrete Frame</p> <p>3 Walling</p> <p>4 Windows</p> <p>5 Doors</p> <p>6 External Finishes</p> <p>7 Internal Finishes</p> <p>9 Balustrade and Railing</p> <p>10 Provisional sums</p>				
	<p><u>TOTAL FOR STUDENT CENTRE CARRIED TO GRAND SUMMARY</u></p>				

PRIME COST SUMS

ITEM	DESCRIPTION	UNIT	QTY	RATE	AMOUNT
PROVISIONAL SUM					
A	Provide a Provisional Sum of Ksh Twenty Million Only (KSH. 20,000,000) for a Rectangular swimming pool overall size 25mx 12.5m x 3m deep, on the deep end and 1.2m on the shallow end including all excavations, waterproofing, back filling, 200mmm thick concreting walling. Finished in ceramic tiling and all associated plumbing and electrical works.	SUM	1	20,000,000	20,000,000.00
B	Provide a Provisional Sum of Ksh Four Million Only (KSH. 4,000,000) for Changing rooms overall size 15mx 3m including all excavations, backing filling, 200mmm thick masonry walling, floor and wall tiling, paint works and all associated plumbing and electrical works	SUM	1	4,000,000	4,000,000.00
PRIME COST SUMS					
UNDERGROUND WATER TANK					
C	Allow a Prime Cost sum of Kenya Shillings Five Million (KSHS. 5,000,000) for provision of an Underground water tank with 350,000 Litres capacity as per Engineers specification.	SUM	1		5,000,000
D	Allow for profits and overheads	%			
E	Allow for attendance	Sum			
LIFT INSTALLATION					
F	Allow a Prime Cost sum of Kenya Shillings Twenty three million, five Hundred thousand (KSHS. 23,500,000) for provision of 4 NO Lifts	SUM	1		23,500,000
G	Allow for profits and overheads	%			
H	Allow for attendance	Sum			
POWER HOUSE					
I	Allow a Prime Cost sum of Kenya Shillings One Million Five Hundred (KSHS. 1,500,000) for provision of a Power House.	SUM	1		1,500,000
J	Allow for profits and overheads	%			
K	Allow for attendance	Sum			
GROUND BREAKING AND SITE HANDOVER					
L	Allow a provisional sum of Kenya Shillings Five hundred thousand Only (KSHS. 500,000) for Ground breaking ceremony and site handover/commissioning.	SUM	1		500,000
M	Allow for profits and overheads	%			
N	Allow for attendance	Sum			
MARKETING ON BOMA YANGU					
O	Allow a prime cost of One million (KSHs. 1,000,000) for Marketing and Support to Boma Yangu Platform	SUM	1		1,000,000
P	Allow for profits and overheads	%			
Q	Allow for attendance	Sum			
PREPARATION AND PRINTING OF RENDERS					
R	Allow a prime cost of Five hundred thousand (KSHs. 500,000) for Preparation of Renders and Printing	SUM	1		500,000
S	Allow for profits and overheads	%			
T	Allow for attendance	Sum			
TOTAL FOR PC SUMS & PROVISIONAL SUMS CARRIED TO GRAND SUMMARY					

GRAND SUMMARY

PROPOSED HOSTEL BLOCKS AND ASSOCIATED INFRASTRUCTURE IN ALUPE UNIVERSITY

GRAND SUMMARY			
ITEM	DESCRIPTION	TENDERER'S AMOUNT	FOR OFFICIAL USE ONLY
1.00	PARTICULAR PRELIMINARIES		
2.00	GENERAL PRELIMINARIES		
3.00	PROJECT PROVISIONS		
4.00	HOSTEL BLOCKS - 2 NO.		
5.00	ELECTRICAL WORKS		
6.00	MECHANICAL WORKS		
7.00	GUARD HOUSE		
8.00	GARBAGE RECEPTACLE		
9.00	BASKET BALL PITCH		
10.00	BOUNDARY WALL		
11.00	CIVIL WORKS - ROADS		
12.00	CIVIL WORKS - SEWER		
13.00	STUDENT'S CENTRE		
14.00	PROVISIONAL SUMS & PC SUMS		
	SUB-TOTAL		
	ADD CONTINGENCY (2%)		
	GRAND TOTAL CARRIED TO FORM OF TENDER (VAT INCLUSIVE)		
AMOUNT IN WORDS : KENYA SHILLINGS TENDERER'S NAME ADDRESS DATE TENDERER'S SIGNATURE WITNESS'S NAME..... ADDRESS DATE WITNESS SIGNATURE.....			

ARCHITECTURAL DRAWINGS

STUDENT HOUSING

ARCHITECTURAL MASTER PLAN

STUDENT HOUSING

SITE PLAN HOSTEL BLOCK
ALUPE HOSTEL SITE LAYOUT G+9

PROJECT DATA

LANDSIZE - 9.302 ACRES
2 No. HOSTEL BLOCKS - 24,684 SM

GENERAL NOTES

1. This drawing to be read in conjunction with Engineers' drawings.
2. All dimensions are in mm unless otherwise specified.
3. Drawings are not to be scaled. Only figured dimensions should be used.
4. The contractor must check and verify all dimensions before commencement of work and if necessary confirm with the architect.

CONSTRUCTION

Approved anti-termite treatment & 1000 gauge polythene sheeting cover to be provided under all ground floor concrete slab on compacted hardcore to approval.
 DPC to be 3ply bituminous felt to be provided under all walls.

STRUCTURAL

1. All Black cotton soil to be removed from below all building and paved surfaces
2. All reinforced concrete work will be in accordance with structural drawings.
3. Foundation depths to be determined on site to S.E approval
4. All walls less than 200mm thick to be reinforced with hoop iron at every alternate course.
5. All adjacent R.C work and masonry walls to be tied with strap irons at every course

MECHANICAL

1. All Plumbing and Drainage Work to comply with specifications
2. S.V.P denotes soil vent pipe and to be provided at the head of the drainage
3. Where drainage is shown under driveways and slabs, to be encased in 150mm thick concrete surround.
4. All underground foul and waste drain pipes shall be of PVC to comply with BS5255
5. All ICs within building area, driveway and parking to have heavy duty, double-seal airtight covers and walls to be 200mm.
6. Minimum slope in the drain pipes to be 1%
7. No chases for pipes will be allowed in the slabs
8. Sleeves will be allowed with written approval from S.E.
9. No cutting of concrete without express approval of the Architect or S.E
10. All testing of pipes must be coordinated with electrical and any conflicts must be resolved before works begin
11. Permanent vents denoted as P.V to be provided as shown on plan.

ELECTRICAL

All conduits must be laid before plastering

PROJECT:

STUDENT HOUSING

CLIENT:

Name: STATE DEPARTMENT FOR HOUSING AND URBAN DEVELOPMENT

Signature: _____ Date: _____

DRAWING TITLE:

SCALE:

1:1000

DRAWN BY:

CHECKED BY:

Name: _____

Signature: _____ Date: _____

DATE:

MINISTRY OF LANDS, PUBLIC WORKS, HOUSING AND URBAN DEVELOPMENT

STATE DEPARTMENT FOR HOUSING & URBAN DEVELOPMENT



FOR THE GOVERNMENT OF THE REPUBLIC OF KENYA

9m ROAD

FUTURE EXPANSION

12m ROAD

9m ROAD

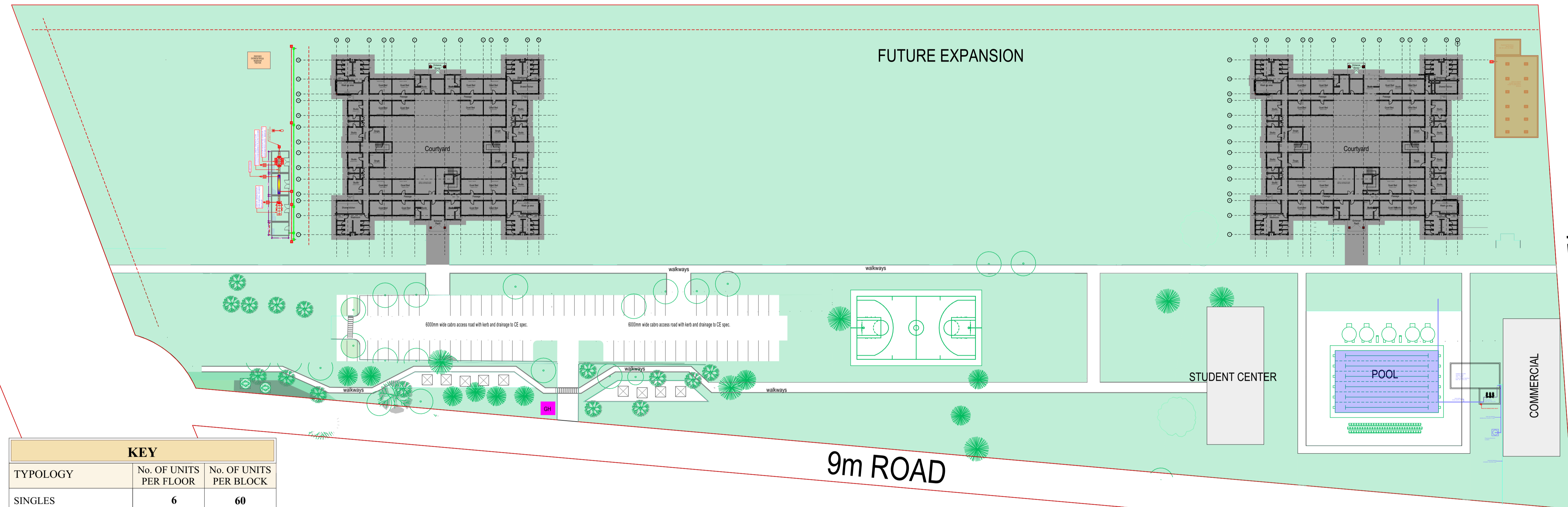

KEY		
TYOLOGY	No. OF UNITS PER FLOOR	No. OF UNITS PER BLOCK
SINGLES	6	60
STUDIOS LOWER.G.F	-	
STUDIOS UPPER.G.F	8	
STUDIOS TYPICAL.F	12	122
QUADS	16	160
TOTAL No. OF UNITS		342
STALLS	4	
OFFICES	4	

KEY	
	HOSTEL BLOCKS
	CIRCULATION AND PARKING
	GATE HOUSE
	WASTE COLLECTION

ALUPE STUDENT HOUSING SITE PLAN



CIVIL WORKS MASTER PLAN

STUDENT HOUSING

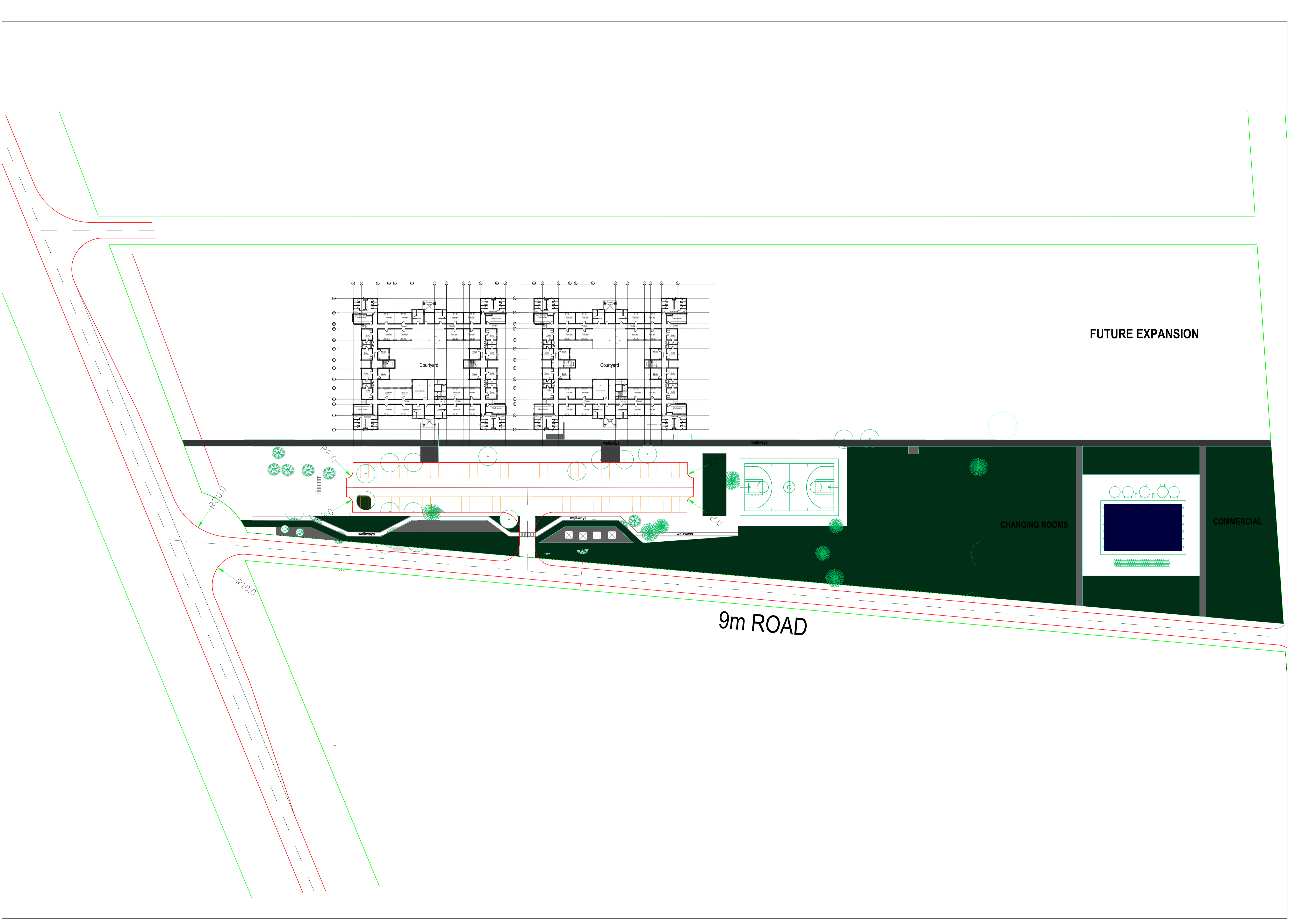

FUTURE EXPANSION

Courtyard

Courtyard

CHANGING ROOMS

COMMERCIAL

9m ROAD

$R40.0$

$R10.0$

$R2.0$

$R2.0$

walkways

walkways

walkways

walkways

walkways

PLANS, SECTIONS AND ELEVATIONS

STUDENT HOUSING

GENERAL NOTES

1. This drawing to be read in conjunction with Engineers' drawings.
2. All dimensions are in mm unless otherwise specified.
3. Drawings are not to be scaled. Only figured dimensions should be used.
4. The contractor must check and verify all dimensions before commencement of work and if necessary confirm with the architect.

CONSTRUCTION

- Approved anti-termite treatment & 1000 gauge polythene sheeting cover to be provided under all ground floor concrete slab on compacted hardcore to approval.
DPC to be 3ply bituminous felt to be provided under all walls.

STRUCTURAL

1. All Black cotton soil to be removed from below all building and paved surfaces
2. All reinforced concrete work will be in accordance with structural drawings.
3. Foundation depths to be determined on site to S.E approval
4. All walls less than 200mm thick to be reinforced with hoop iron at every alternate course.
5. All adjacent R.C work and masonry walls to be tied with strap irons at every course

MECHANICAL

1. All Plumbing and Drainage Work to comply with specifications
2. S.V.P denotes soil vent pipe and to be provided at the head of the drainage
3. Where drainage is shown under driveways and slabs, to be encased in 150mm thick concrete surround.
4. All underground foul and waste drain pipes shall be of PVC to comply with BS5255
5. All ICs within building area driveway and parking to have heavy duty, double-seal airtight covers and walls to be 200mm.
6. Minimum slope in the drain pipes to be 1%
7. No chases for pipes will be allowed in the slabs
8. Sleeves will be allowed with written approval from S.E.
9. No cutting of concrete without express approval of the Architect or S.E
10. All testing of pipes must be coordinated with electrical and any conflicts must be resolved before works begin
11. Permanent vents denoted as P.V to be provided as shown on plan.

ELECTRICAL

All conduits must be laid before plastering

PROJECT:

PROPOSED STUDENT HOUSING FOR ALUPE UNIVERSITY

CLIENT:

Name: STATE DEPARTMENT FOR HOUSING AND URBAN DEVELOPMENT

Signature: _____ Date: _____

DRAWING TITLE:
LOWER GROUND FLOOR PLAN

SCALE:

1:100

DRAWN BY:

CHECKED BY:

Name: _____

Signature: _____ Date: _____

DATE:

MINISTRY OF LANDS, PUBLIC WORKS, HOUSING AND URBAN DEVELOPMENT

STATE DEPARTMENT FOR HOUSING & URBAN DEVELOPMENT



FOR THE GOVERNMENT OF THE REPUBLIC OF KENYA

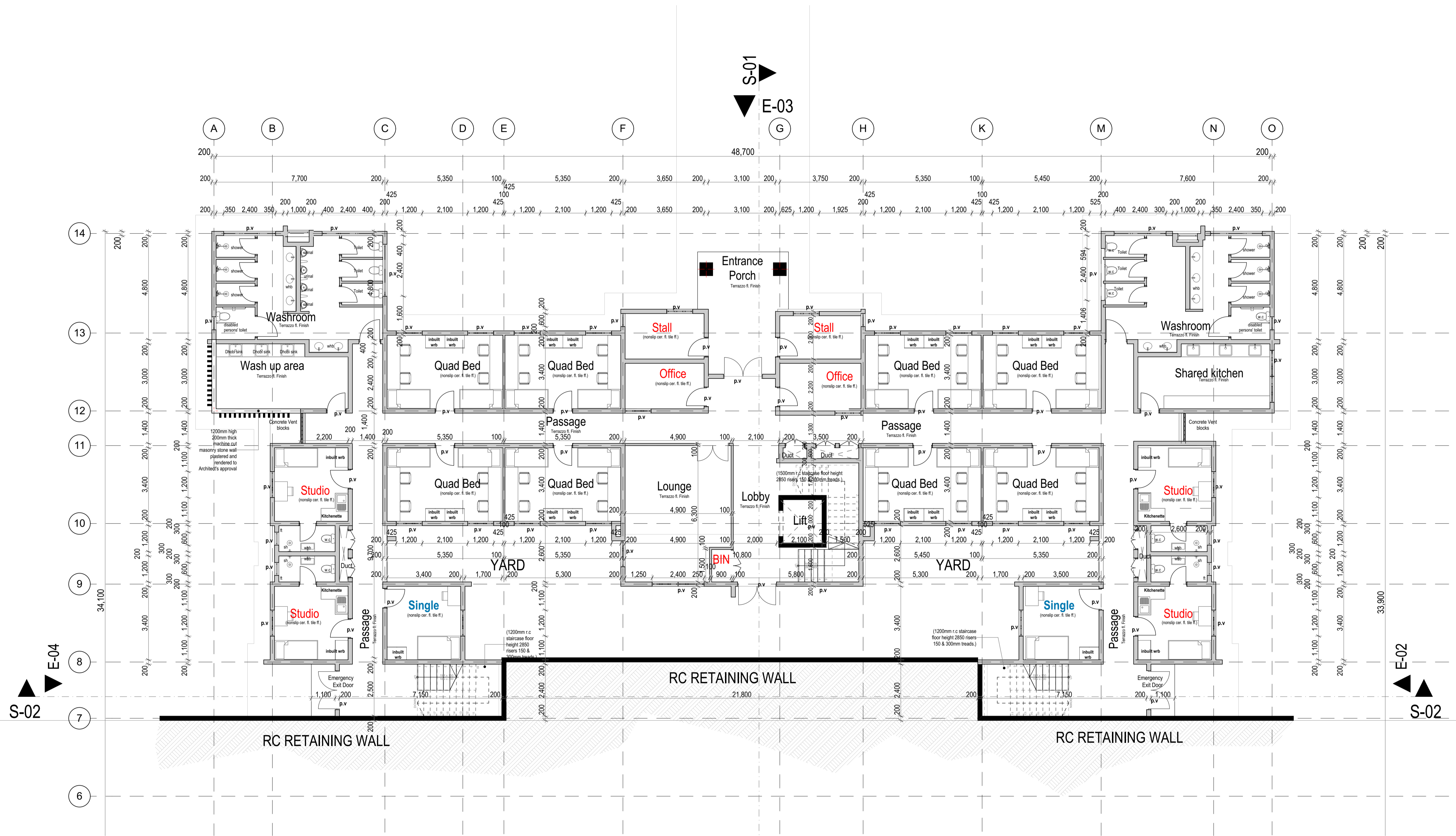

LOWER GROUND FLOOR PLAN

SCALE 1:100

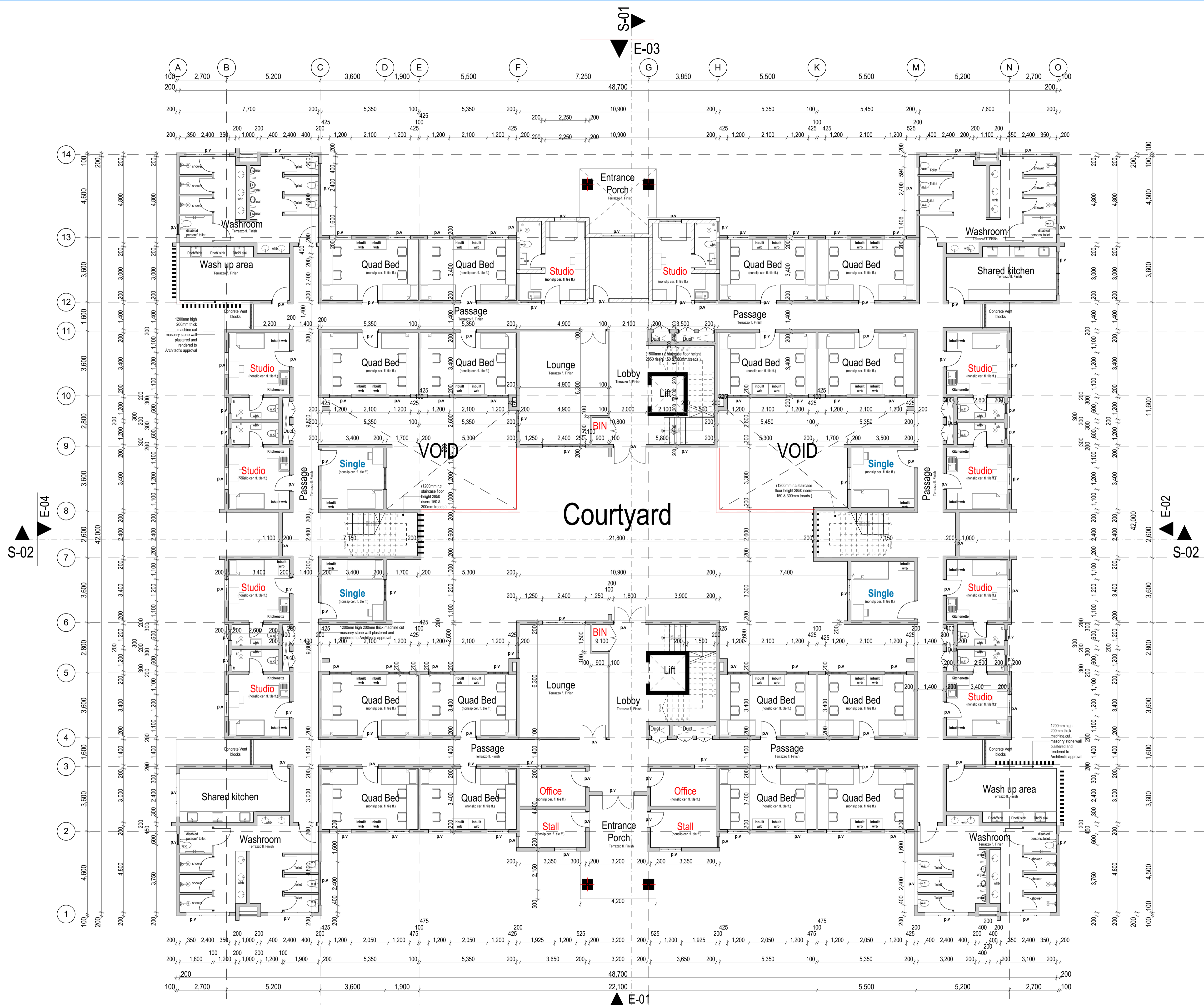

UPPER GROUND FLOOR PLAN

SCALE 1:100

GENERAL NOTES

1. This drawing to be read in conjunction with Engineers' drawings.
2. All dimensions are in mm unless otherwise specified.
3. Drawings are not to be scaled. Only figured dimensions should be used.
4. The contractor must check and verify all dimensions before commencement of work and if necessary confirm with the architect.

CONSTRUCTION

Approved anti-termite treatment & 1000 gauge polythene sheeting cover to be provided under all ground floor concrete slab on compacted hardcore to approval.
 DPC to be 3ply bituminous felt to be provided under all walls.

STRUCTURAL

1. All Black cotton soil to be removed from below all building and paved surfaces
2. All reinforced concrete work will be in accordance with structural drawings.
3. Foundation depths to be determined on site to S.E approval
4. All walls less than 200mm thick to be reinforced with hoop iron at every alternate course.
5. All adjacent R.C work and masonry walls to be tied with strap irons at every course

MECHANICAL

1. All Plumbing and Drainage Work to comply with specifications
2. S.V.P denotes soil vent pipe and to be provided at the head of the drainage
3. Where drainage is shown under driveways and slabs, to be encased in 150mm thick concrete surround.
4. All underground foul and waste drain pipes shall be of PVC to comply with BS5255
5. All ICs within building area driveway and parking to have heavy duty, double-seal airtight covers and walls to be 200mm.
6. Minimum slope in the drain pipes to be 1%
7. No chases for pipes will be allowed in the slabs
8. Sleeves will be allowed with written approval from S.E.
9. No cutting of concrete without express approval of the Architect or S.E
10. All testing of pipes must be coordinated with electrical and any conflicts must be resolved before works begin
11. Permanent vents denoted as P.V to be provided as shown on plan.

ELECTRICAL

All conduits must be laid before plastering

PROJECT:

PROPOSED STUDENT HOUSING FOR ALUPE UNIVERSITY

CLIENT:

Name: STATE DEPARTMENT FOR HOUSING AND URBAN DEVELOPMENT

Signature: _____ Date: _____

DRAWING TITLE: UPPER GROUND FLOOR PLAN

SCALE:

1:100

DRAWN BY:

CHECKED BY:

Name: _____

Signature: _____ Date: _____

DATE:

MINISTRY OF LANDS, PUBLIC WORKS, HOUSING AND URBAN DEVELOPMENT

STATE DEPARTMENT FOR HOUSING & URBAN DEVELOPMENT



FOR THE GOVERNMENT OF THE REPUBLIC OF KENYA

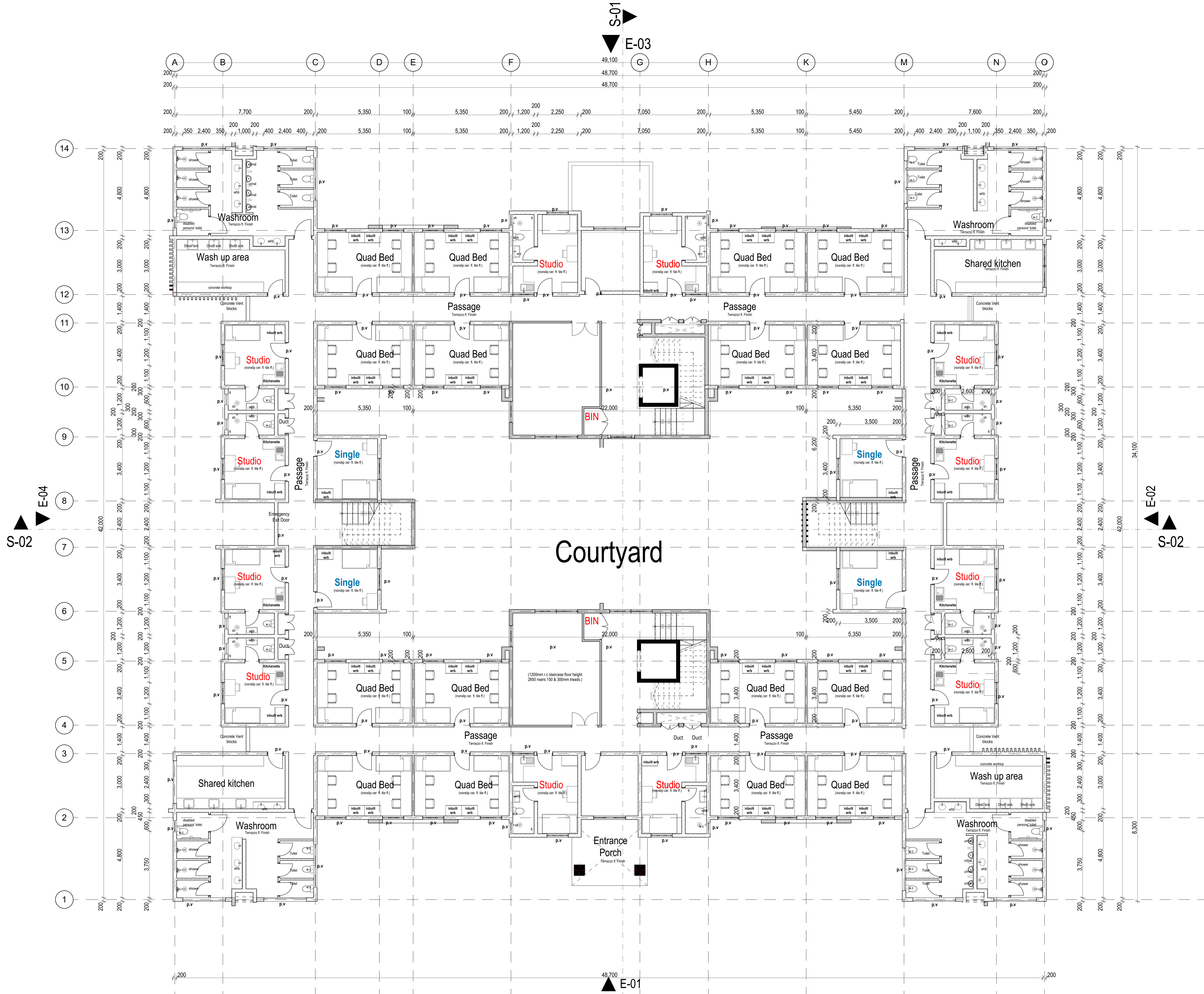

FIRST FLOOR PLAN

GENERAL NOTES

1. This drawing to be read in conjunction with Engineers' drawings.
2. All dimensions are in mm unless otherwise specified.
3. Drawings are not to be scaled. Only figured dimensions should be used.
4. The contractor must check and verify all dimensions before commencement of work and if necessary confirm with the architect.

CONSTRUCTION

Approved anti-termite treatment & 1000 gauge polythene sheeting cover to be provided under all ground floor concrete slab on compacted hardcore to approval.
 DPC to be 3ply bituminous felt to be provided under all walls.

STRUCTURAL

1. All Black cotton soil to be removed from below all building and paved surfaces
2. All reinforced concrete work will be in accordance with structural drawings.
3. Foundation depths to be determined on site to S.E approval
4. All walls less than 200mm thick to be reinforced with hoop iron at every alternate course.
5. All adjacent R.C work and masonry walls to be tied with strap irons at every course

MECHANICAL

1. All Plumbing and Drainage Work to comply with specifications
2. S.V.P denotes soil vent pipe and to be provided at the head of the drainage
3. Where drainage is shown under driveways and slabs, to be encased in 150mm thick concrete surround.
4. All underground foul and waste drain pipes shall be of PVC to comply with BS5255
5. All ICs within building area driveway and parking to have heavy duty double-seal airtight covers and walls to be 200mm.
6. Minimum slope in the drain pipes to be 1%
7. No chases for pipes will be allowed in the slabs
8. Sleeves will be allowed with written approval from S.E.
9. No cutting of concrete without express approval of the Architect or S.E
10. All testing of pipes must be coordinated with electrical and any conflicts must be resolved before works begin
11. Permanent vents denoted as P.V to be provided as shown on plan.

ELECTRICAL

All conduits must be laid before plastering

PROJECT:

PROPOSED STUDENT HOUSING FOR ALUPE UNIVERSITY

CLIENT:

Name: STATE DEPARTMENT FOR HOUSING AND URBAN DEVELOPMENT

Signature: _____ Date: _____

DRAWING TITLE:

FIRST FLOOR PLAN

SCALE:

1:100

DRAWN BY:

CHECKED BY:

Name: _____

Signature: _____ Date: _____

DATE:

MINISTRY OF LANDS, PUBLIC WORKS, HOUSING AND URBAN DEVELOPMENT

STATE DEPARTMENT FOR HOUSING & URBAN DEVELOPMENT



FOR THE GOVERNMENT OF THE REPUBLIC OF KENYA

S-01

E-03

E-01

2ND FLOOR PLAN

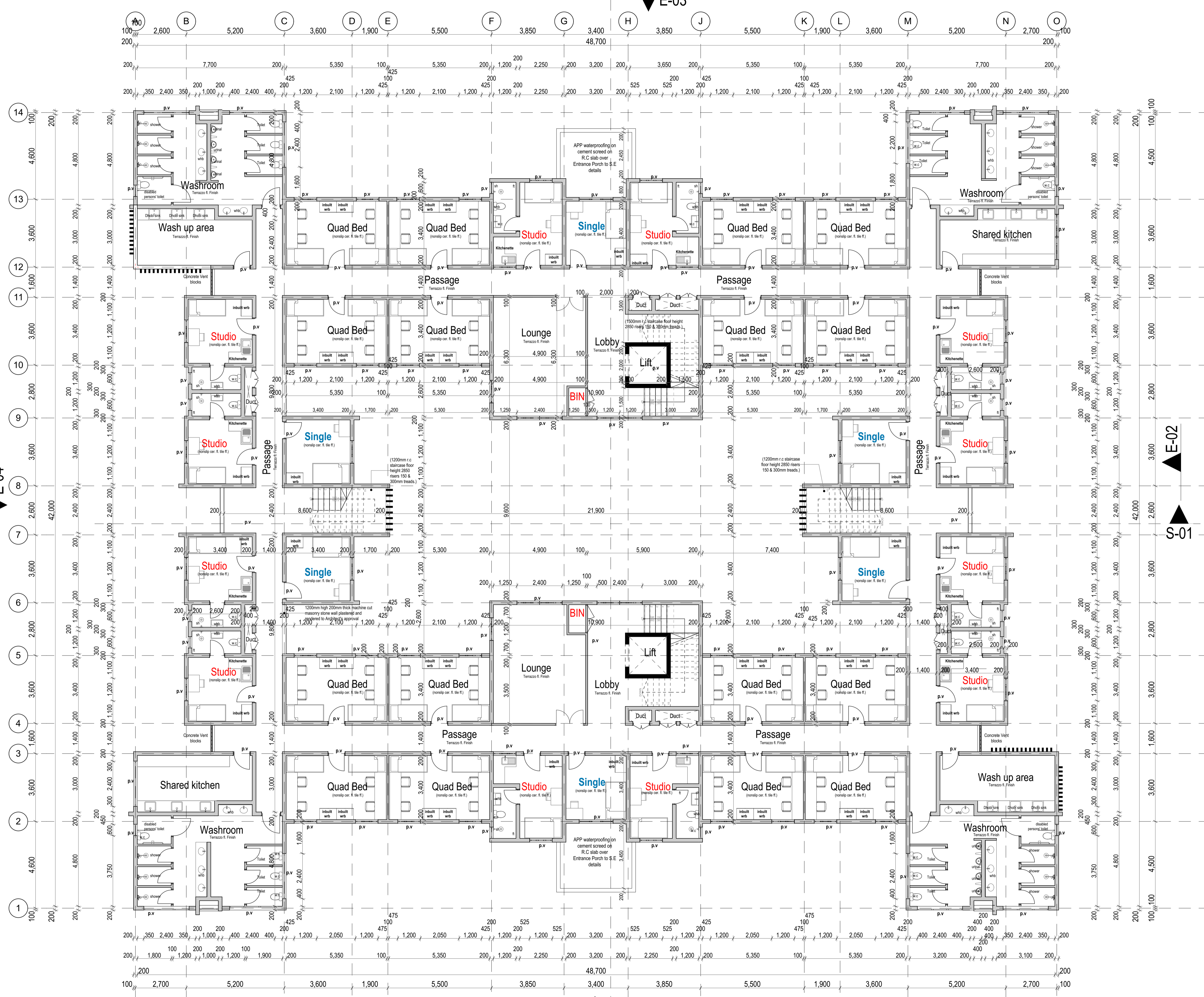

GENERAL NOTES

1. This drawing to be read in conjunction with Engineers' drawings.
2. All dimensions are in mm unless otherwise specified.
3. Drawings are not to be scaled. Only figured dimensions should be used.
4. The contractor must check and verify all dimensions before commencement of work and if necessary confirm with the architect.

CONSTRUCTION

Approved anti-termite treatment & 1000 gauge polythene sheeting cover to be provided under all ground floor concrete slab on compacted hardcore to approval.
 DPC to be 3ply bituminous felt to be provided under all walls.

STRUCTURAL

1. All Black cotton soil to be removed from below all building and paved surfaces
2. All reinforced concrete work will be in accordance with structural drawings.
3. Foundation depths to be determined on site to S.E approval
4. All walls less than 200mm thick to be reinforced with hoop iron at every alternate course.
5. All adjacent R.C work and masonry walls to be tied with strap irons at every course

MECHANICAL

1. All Plumbing and Drainage Work to comply with specifications
2. S.V.P denotes soil vent pipe and to be provided at the head of the drainage
3. Where drainage is shown under driveways and slabs, to be encased in 150mm thick concrete surround.
4. All underground foul and waste drain pipes shall be of PVC to comply with BS5255
5. All ICs within building area driveway and parking to have heavy duty, double-seal airtight covers and walls to be 200mm.
6. Minimum slope in the drain pipes to be 1%
7. No chases for pipes will be allowed in the slabs
8. Sleeves will be allowed with written approval from S.E.
9. No cutting of concrete without express approval of the Architect or S.E
10. All testing of pipes must be coordinated with electrical and any conflicts must be resolved before works begin
11. Permanent vents denoted as P.V to be provided as shown on plan.

ELECTRICAL

All conduits must be laid before plastering

PROJECT:

PROPOSED STUDENT HOUSING FOR ALUPE UNIVERSITY

CLIENT:

Name: STATE DEPARTMENT FOR HOUSING AND URBAN DEVELOPMENT

Signature: _____ Date: _____

DRAWING TITLE:

2ND FLOOR PLAN

SCALE:

1:100

DRAWN BY:

Signature: _____ Date: _____

CHECKED BY:

Name: _____

Signature: _____ Date: _____

DATE:

Signature: _____ Date: _____

MINISTRY OF LANDS, PUBLIC WORKS, HOUSING AND URBAN DEVELOPMENT

STATE DEPARTMENT FOR HOUSING & URBAN DEVELOPMENT



FOR THE GOVERNMENT OF THE REPUBLIC OF KENYA

S-01
E-03

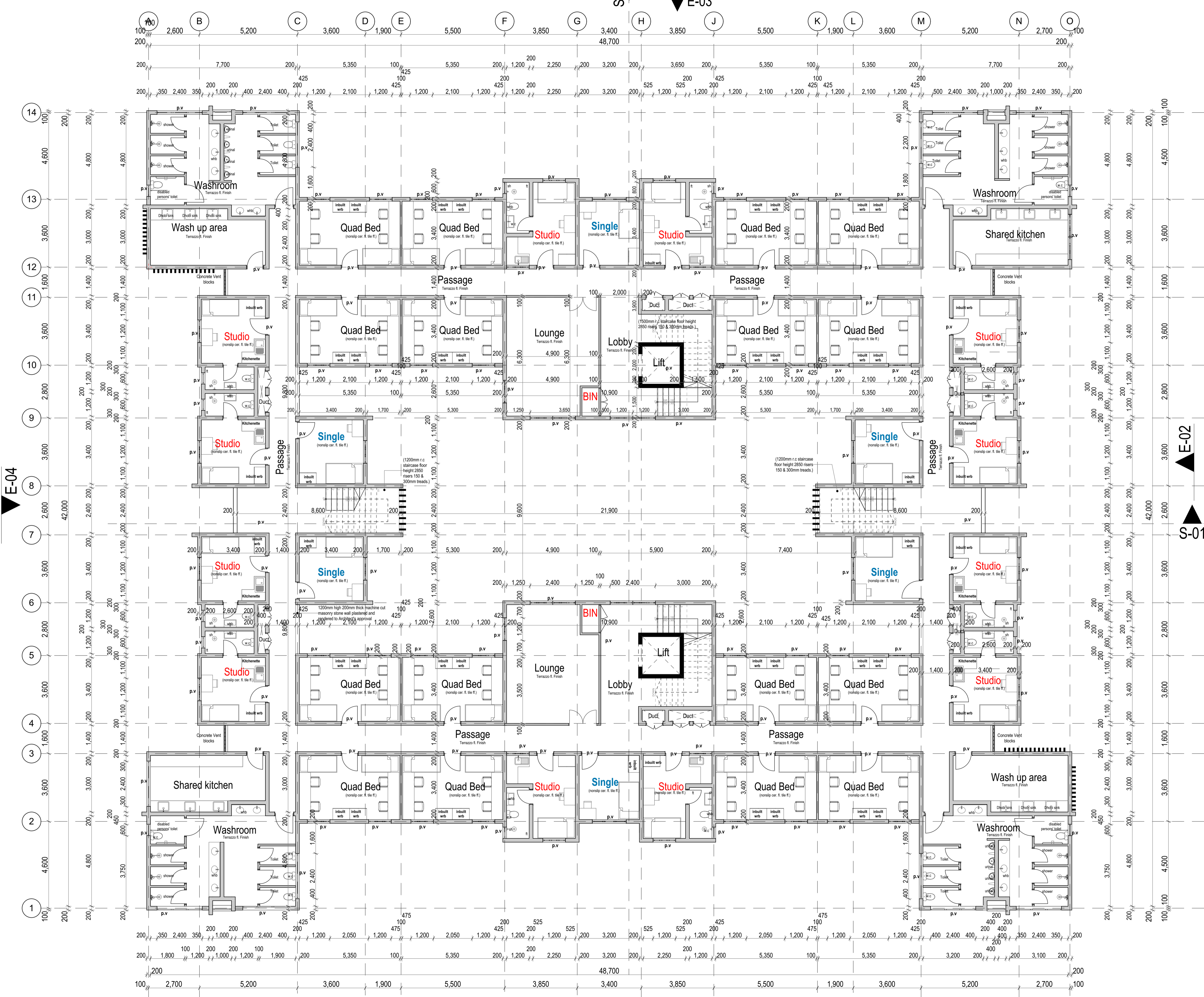

3RD - 9TH TYPICAL FLOOR PLANS

GENERAL NOTES

1. This drawing to be read in conjunction with Engineers' drawings.
2. All dimensions are in mm unless otherwise specified.
3. Drawings are not to be scaled. Only figured dimensions should be used.
4. The contractor must check and verify all dimensions before commencement of work and if necessary confirm with the architect.

CONSTRUCTION

Approved anti-termite treatment & 1000 gauge polythene sheeting cover to be provided under all ground floor concrete slab on compacted hardcore to approval.
DPC to be 3ply bituminous felt to be provided under all walls.

STRUCTURAL

1. All Black cotton soil to be removed from below all building and paved surfaces
2. All reinforced concrete work will be in accordance with structural drawings.
3. Foundation depths to be determined on site to S.E approval
4. All walls less than 200mm thick to be reinforced with hoop iron at every alternate course.
5. All adjacent R.C work and masonry walls to be tied with strap irons at every course

MECHANICAL

1. All Plumbing and Drainage Work to comply with specifications
2. S.V.P denotes soil vent pipe and to be provided at the head of the drainage
3. Where drainage is shown under driveways and slabs, to be encased in 150mm thick concrete surround.
4. All underground foul and waste drain pipes shall be of PVC to comply with BS5255
5. All ICs within building area driveway and parking to have heavy duty, double-seal airtight covers and walls to be 200mm.
6. Minimum slope in the drain pipes to be 1%
7. No chases for pipes will be allowed in the slabs
8. Sleeves will be allowed with written approval from S.E.
9. No cutting of concrete without express approval of the Architect or S.E
10. All testing of pipes must be coordinated with electrical and any conflicts must be resolved before works begin
11. Permanent vents denoted as P.V to be provided as shown on plan.

ELECTRICAL

All conduits must be laid before plastering

PROJECT:

PROPOSED STUDENT HOUSING FOR ALUPE UNIVERSITY

CLIENT:

Name: STATE DEPARTMENT FOR HOUSING AND URBAN DEVELOPMENT

Signature: _____ Date: _____

DRAWING TITLE:

3RD - 9TH TYPICAL FLOOR PLAN

SCALE:

1:100

DRAWN BY:

CHECKED BY:

Name: _____

Signature: _____ Date: _____

DATE:

MINISTRY OF LANDS, PUBLIC WORKS, HOUSING AND URBAN DEVELOPMENT

STATE DEPARTMENT FOR HOUSING & URBAN DEVELOPMENT



FOR THE GOVERNMENT OF THE REPUBLIC OF KENYA

GENERAL NOTES

1. This drawing to be read in conjunction with Engineers' drawings.
2. All dimensions are in mm unless otherwise specified.
3. Drawings are not to be scaled. Only figured dimensions should be used.
4. The contractor must check and verify all dimensions before commencement of work and if necessary confirm with the architect.

CONSTRUCTION

Approved anti-termite treatment & 1000 gauge polythene sheeting cover to be provided under all ground floor concrete slab on compacted hardcore to approval.
DPC to be 3ply bituminous felt to be provided under all walls.

STRUCTURAL

1. All Black cotton soil to be removed from below all building and paved surfaces
2. All reinforced concrete work will be in accordance with structural drawings.
3. Foundation depths to be determined on site to S.E approval
4. All walls less than 200mm thick to be reinforced with hoop iron at every alternate course.
5. All adjacent R.C work and masonry walls to be tied with strap irons at every course

MECHANICAL

1. All Plumbing and Drainage Work to comply with specifications
2. S.V.P denotes soil vent pipe and to be provided at the head of the drainage
3. Where drainage is shown under driveways and slabs, to be encased in 150mm thick concrete surround.
4. All underground foul and waste drain pipes shall be of PVC to comply with BS5255
5. All ICs within building area driveway and parking to have heavy duty double-seal airtight covers and walls to be 200mm.
6. Minimum slope in the drain pipes to be 1%
7. No chases for pipes will be allowed in the slabs
8. Sleeves will be allowed with written approval from S.E.
9. No cutting of concrete without express approval of the Architect or S.E
10. All testing of pipes must be coordinated with electrical and any conflicts must be resolved before works begin
11. Permanent vents denoted as P.V to be provided as shown on plan.

ELECTRICAL

All conduits must be laid before plastering

PROJECT:

PROPOSED STUDENT HOUSING FOR ALUPE UNIVERSITY

CLIENT:

Name: STATE DEPARTMENT FOR HOUSING AND URBAN DEVELOPMENT

Signature: _____ Date: _____

DRAWING TITLE:
TERRACE PLAN

SCALE:

1:100

DRAWN BY:

CHECKED BY:

Name: _____

Signature: _____ Date: _____

DATE:

MINISTRY OF LANDS, PUBLIC WORKS, HOUSING AND URBAN DEVELOPMENT

STATE DEPARTMENT FOR HOUSING & URBAN DEVELOPMENT



FOR THE GOVERNMENT OF THE REPUBLIC OF KENYA

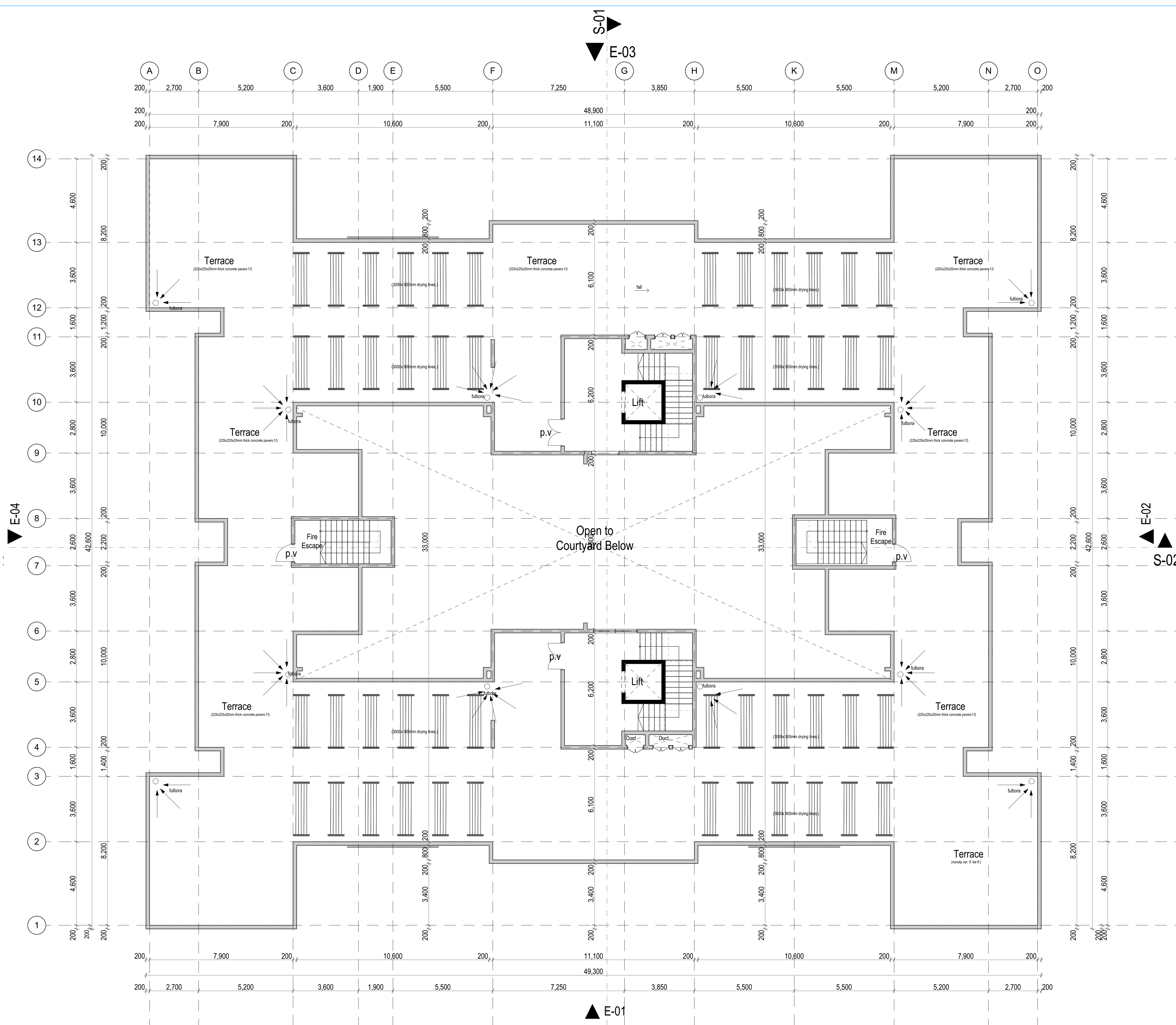

TERRACE PLAN

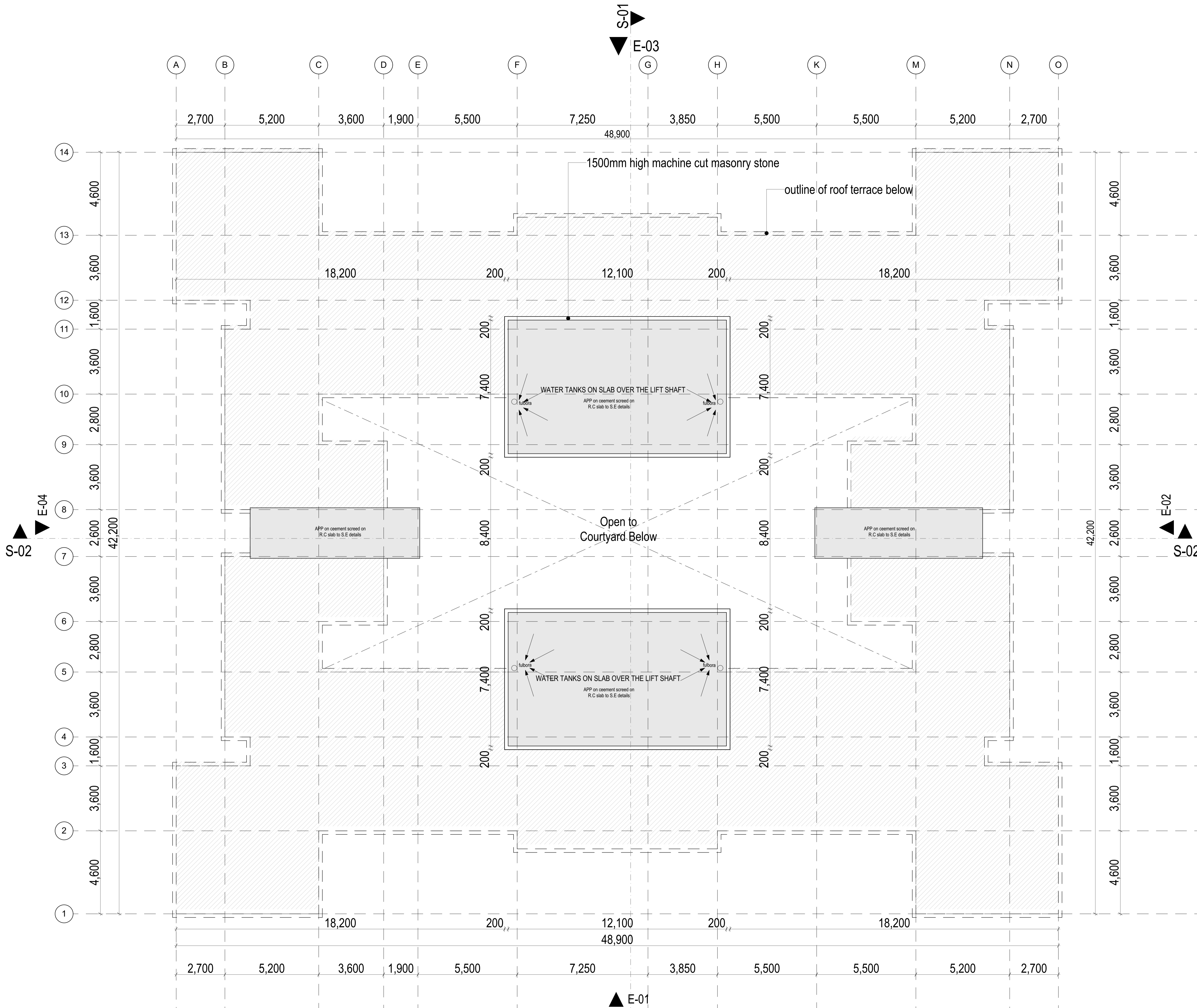

ROOF SLAB PLAN

GENERAL NOTES

1. This drawing to be read in conjunction with Engineers' drawings.
2. All dimensions are in mm unless otherwise specified.
3. Drawings are not to be scaled. Only figured dimensions should be used.
4. The contractor must check and verify all dimensions before commencement of work and if necessary confirm with the architect.

CONSTRUCTION

Approved anti-termite treatment & 1000 gauge polythene sheeting cover to be provided under all ground floor concrete slab on compacted hardcore to approval.
DPC to be 3ply bituminous felt to be provided under all walls.

STRUCTURAL

1. All Black cotton soil to be removed from below all building and paved surfaces
2. All reinforced concrete work will be in accordance with structural drawings.
3. Foundation depths to be determined on site to S.E approval
4. All walls less than 200mm thick to be reinforced with hoop iron at every alternate course.
5. All adjacent R.C work and masonry walls to be tied with strap irons at every course

MECHANICAL

1. All Plumbing and Drainage Work to comply with specifications
2. S.V.P denotes soil vent pipe and to be provided at the head of the drainage
3. Where drainage is shown under driveways and slabs, to be encased in 150mm thick concrete surround.
4. All underground foul and waste drain pipes shall be of PVC to comply with BS5255
5. All ICs within building area driveway and parking to have heavy duty, double-seal airtight covers and walls to be 200mm.
6. Minimum slope in the drain pipes to be 1%
7. No chases for pipes will be allowed in the slabs
8. Sleeves will be allowed with written approval from S.E.
9. No cutting of concrete without express approval of the Architect or S.E
10. All testing of pipes must be coordinated with electrical and any conflicts must be resolved before works begin
11. Permanent vents denoted as P.V to be provided as shown on plan.

ELECTRICAL

All conduits must be laid before plastering

PROJECT:

PROPOSED STUDENT HOUSING FOR ALUPE UNIVERSITY

CLIENT:

Name: STATE DEPARTMENT FOR HOUSING AND URBAN DEVELOPMENT

Signature: _____ Date: _____

DRAWING TITLE:

ROOF SLAB PLAN

SCALE:

1:100

DRAWN BY:

CHECKED BY:

Name: _____

Signature: _____ Date: _____

DATE:

MINISTRY OF LANDS, PUBLIC WORKS, HOUSING AND URBAN DEVELOPMENT

STATE DEPARTMENT FOR HOUSING & URBAN DEVELOPMENT



FOR THE GOVERNMENT OF THE REPUBLIC OF KENYA

GENERAL NOTES

1. This drawing to be read in conjunction with Engineers' drawings.
2. All dimensions are in mm unless otherwise specified.
3. Drawings are not to be scaled. Only figured dimensions should be used.
4. The contractor must check and verify all dimensions before commencement of work and if necessary confirm with the architect.

CONSTRUCTION

Approved anti-termite treatment & 1000 gauge polythene sheeting cover to be provided under all ground floor concrete slab on compacted hardcore to approval.
DPC to be 3ply bituminous felt to be provided under all walls.

STRUCTURAL

1. All Black cotton soil to be removed from below all building and paved surfaces
2. All reinforced concrete work will be in accordance with structural drawings.
3. Foundation depths to be determined on site to S.E approval
4. All walls less than 200mm thick to be reinforced with hoop iron at every alternate course.
5. All adjacent R.C work and masonry walls to be tied with strap irons at every course

MECHANICAL

1. All Plumbing and Drainage Work to comply with specifications
2. S.V.P denotes soil vent pipe and to be provided at the head of the drainage
3. Where drainage is shown under driveways and slabs, to be encased in 150mm thick concrete surround.
4. All underground foul and waste drain pipes shall be of PVC to comply with BS5255
5. All ICs within building area driveway and parking to have heavy duty, double-seal airtight covers and walls to be 200mm.
6. Minimum slope in the drain pipes to be 1%
7. No chases for pipes will be allowed in the slabs
8. Sleeves will be allowed with written approval from S.E.
9. No cutting of concrete without express approval of the Architect or S.E
10. All testing of pipes must be coordinated with electrical and any conflicts must be resolved before works begin
11. Permanent vents denoted as P.V to be provided as shown on plan.

ELECTRICAL

All conduits must be laid before plastering

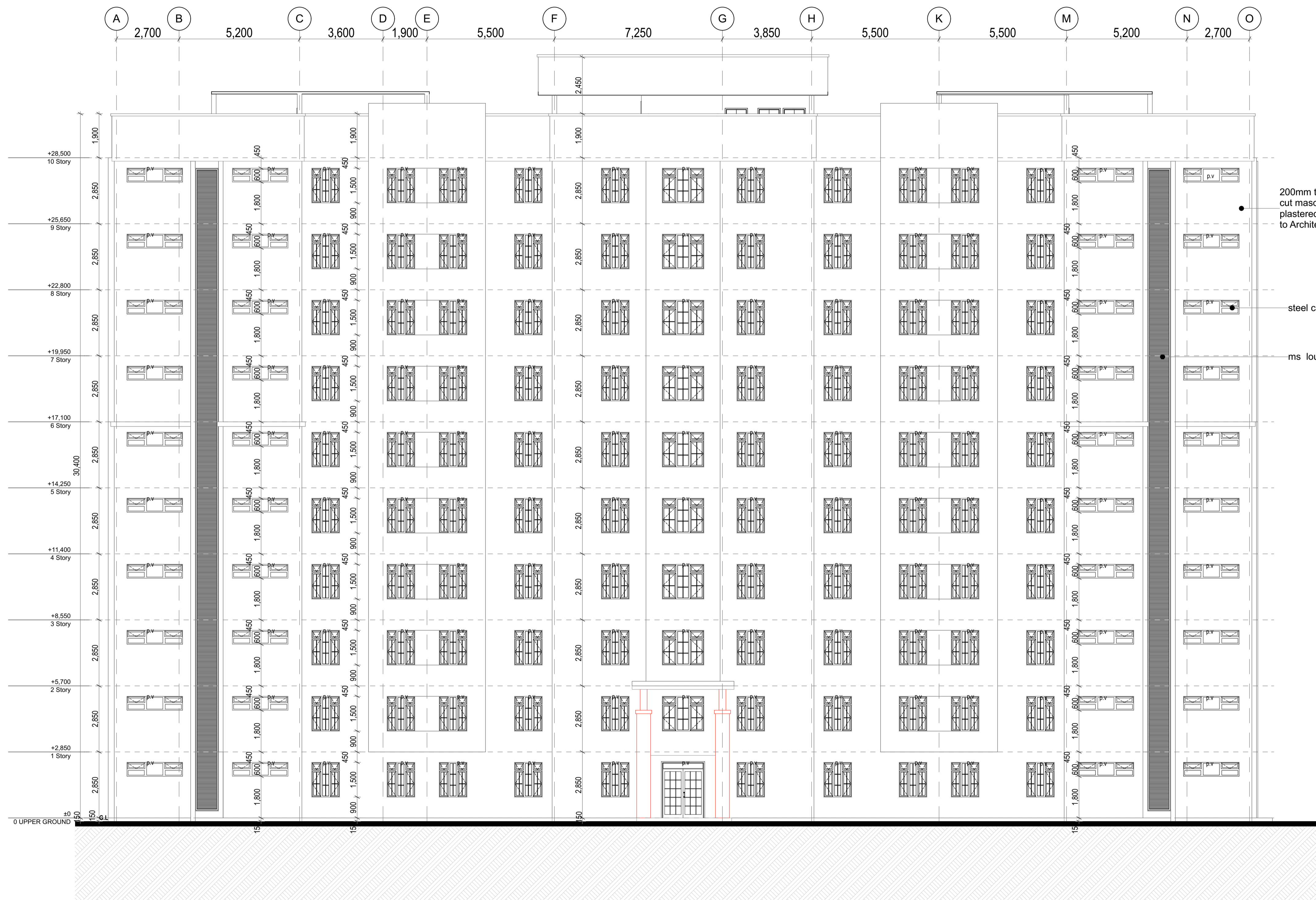

ELEVATION 01

PROJECT:

PROPOSED STUDENT HOUSING FOR ALUPE UNIVERSITY

CLIENT:

Name: STATE DEPARTMENT FOR HOUSING AND URBAN DEVELOPMENT

Signature: _____ Date: _____

DRAWING TITLE:
ELEVATION 01

SCALE:
1:100

DRAWN BY:

CHECKED BY:

Name: _____

Signature: _____ Date: _____

DATE:

MINISTRY OF LANDS, PUBLIC WORKS, HOUSING AND URBAN DEVELOPMENT

STATE DEPARTMENT FOR HOUSING & URBAN DEVELOPMENT



FOR THE GOVERNMENT OF THE REPUBLIC OF KENYA



ELEVATION 02

GENERAL NOTES

1. This drawing to be read in conjunction with Engineers' drawings.
2. All dimensions are in mm unless otherwise specified.
3. Drawings are not to be scaled. Only figured dimensions should be used.
4. The contractor must check and verify all dimensions before commencement of work and if necessary confirm with the architect.

CONSTRUCTION

Approved anti-termite treatment & 1000 gauge polythene sheeting cover to be provided under all ground floor concrete slab on compacted hardcore to approval.
DPC to be 3ply bituminous felt to be provided under all walls.

STRUCTURAL

1. All Black cotton soil to be removed from below all building and paved surfaces
2. All reinforced concrete work will be in accordance with structural drawings.
3. Foundation depths to be determined on site to S.E approval
4. All walls less than 200mm thick to be reinforced with hoop iron at every alternate course.
5. All adjacent R.C work and masonry walls to be tied with strap irons at every course

MECHANICAL

1. All Plumbing and Drainage Work to comply with specifications
2. S.V.P denotes soil vent pipe and to be provided at the head of the drainage
3. Where drainage is shown under driveways and slabs, to be encased in 150mm thick concrete surround.
4. All underground foul and waste drain pipes shall be of PVC to comply with BS5255
5. All ICs within building area driveway and parking to have heavy duty, double-seal airtight covers and walls to be 200mm.
6. Minimum slope in the drain pipes to be 1%
7. No chases for pipes will be allowed in the slabs
8. Sleeves will be allowed with written approval from S.E.
9. No cutting of concrete without express approval of the Architect or S.E
10. All testing of pipes must be coordinated with electrical and any conflicts must be resolved before works begin
11. Permanent vents denoted as P.V to be provided as shown on plan.

ELECTRICAL

All conduits must be laid before plastering

PROJECT:

PROPOSED STUDENT HOUSING FOR ALUPE UNIVERSITY

CLIENT:

Name: STATE DEPARTMENT FOR HOUSING AND URBAN DEVELOPMENT

Signature: _____ Date: _____

DRAWING TITLE:
ELEVATION 02

SCALE:
1:100

DRAWN BY:

CHECKED BY:

Name: _____

Signature: _____ Date: _____

DATE:

MINISTRY OF LANDS, PUBLIC WORKS, HOUSING AND URBAN DEVELOPMENT

STATE DEPARTMENT FOR HOUSING & URBAN DEVELOPMENT



FOR THE GOVERNMENT OF THE REPUBLIC OF KENYA

GENERAL NOTES

1. This drawing to be read in conjunction with Engineers' drawings.
2. All dimensions are in mm unless otherwise specified.
3. Drawings are not to be scaled. Only figured dimensions should be used.
4. The contractor must check and verify all dimensions before commencement of work and if necessary confirm with the architect.

CONSTRUCTION

Approved anti-termite treatment & 1000 gauge polythene sheeting cover to be provided under all ground floor concrete slab on compacted hardcore to approval.
DPC to be 3ply bituminous felt to be provided under all walls.

STRUCTURAL

1. All Black cotton soil to be removed from below all building and paved surfaces
2. All reinforced concrete work will be in accordance with structural drawings.
3. Foundation depths to be determined on site to S.E approval
4. All walls less than 200mm thick to be reinforced with hoop iron at every alternate course.
5. All adjacent R.C work and masonry walls to be tied with strap irons at every course

MECHANICAL

1. All Plumbing and Drainage Work to comply with specifications
2. S.V.P denotes soil vent pipe and to be provided at the head of the drainage
3. Where drainage is shown under driveways and slabs, to be encased in 150mm thick concrete surround.
4. All underground foul and waste drain pipes shall be of PVC to comply with BS5255
5. All ICs within building area driveway and parking to have heavy duty double-seal airtight covers and walls to be 200mm.
6. Minimum slope in the drain pipes to be 1%
7. No chases for pipes will be allowed in the slabs
8. Sleeves will be allowed with written approval from S.E.
9. No cutting of concrete without express approval of the Architect or S.E
10. All testing of pipes must be coordinated with electrical and any conflicts must be resolved before works begin
11. Permanent vents denoted as P.V to be provided as shown on plan.

ELECTRICAL

All conduits must be laid before plastering

PROJECT:

PROPOSED STUDENT HOUSING FOR ALUPE UNIVERSITY

CLIENT:

Name: STATE DEPARTMENT FOR HOUSING AND URBAN DEVELOPMENT

Signature: _____ Date: _____

DRAWING TITLE: ELEVATION 03

SCALE:

1:100

DRAWN BY:

CHECKED BY:

Name: _____

Signature: _____ Date: _____

DATE:

MINISTRY OF LANDS, PUBLIC WORKS, HOUSING AND URBAN DEVELOPMENT

STATE DEPARTMENT FOR HOUSING & URBAN DEVELOPMENT



FOR THE GOVERNMENT OF THE
REPUBLIC OF KENYA

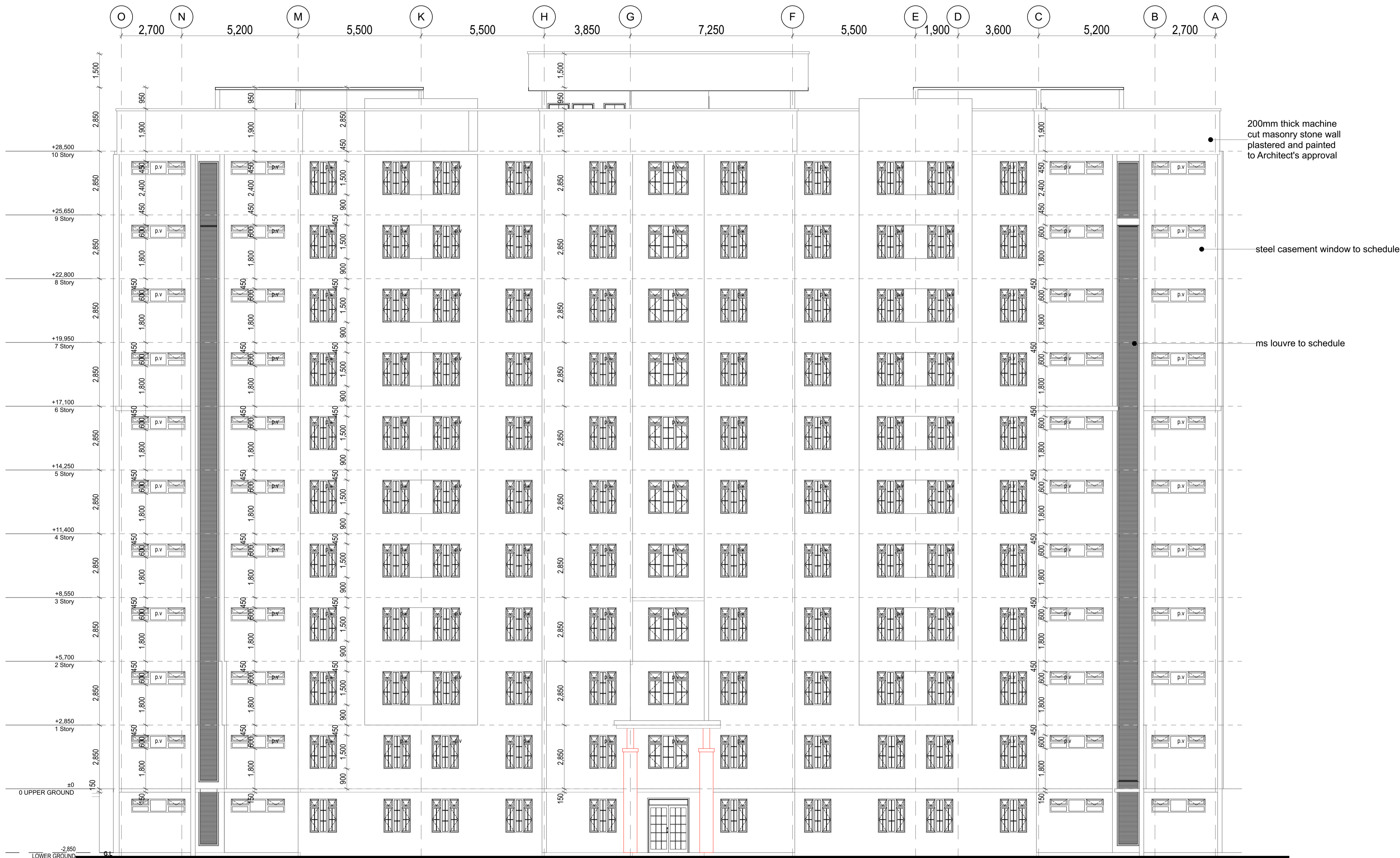

ELEVATION 03

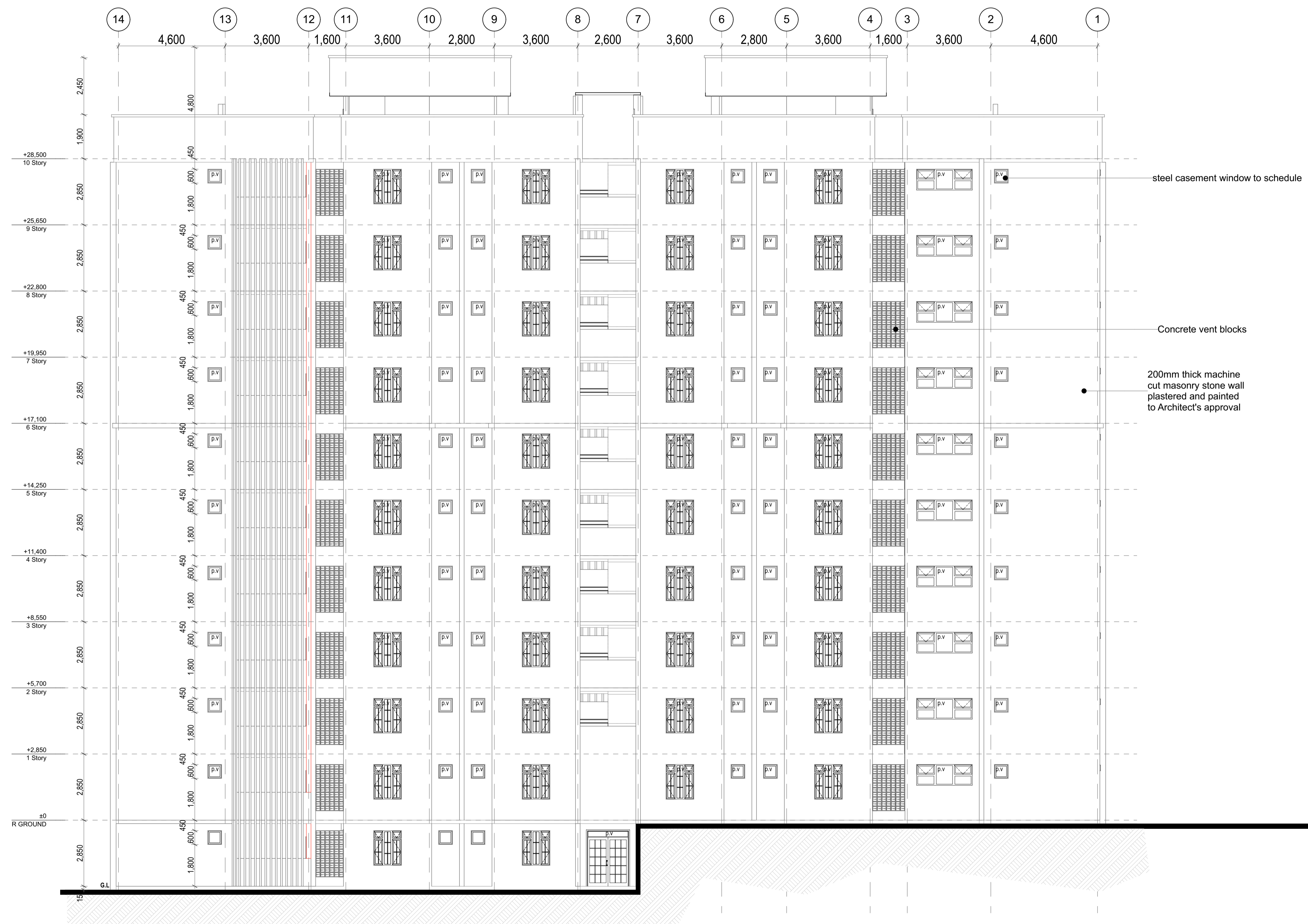

ELEVATION 04

GENERAL NOTES

1. This drawing to be read in conjunction with Engineers' drawings.
2. All dimensions are in mm unless otherwise specified.
3. Drawings are not to be scaled. Only figured dimensions should be used.
4. The contractor must check and verify all dimensions before commencement of work and if necessary confirm with the architect.

CONSTRUCTION

Approved anti-termite treatment & 1000 gauge polythene sheeting cover to be provided under all ground floor concrete slab on compacted hardcore to approval.
DPC to be 3ply bituminous felt to be provided under all walls.

STRUCTURAL

1. All Black cotton soil to be removed from below all building and paved surfaces
2. All reinforced concrete work will be in accordance with structural drawings.
3. Foundation depths to be determined on site to S.E approval
4. All walls less than 200mm thick to be reinforced with hoop iron at every alternate course.
5. All adjacent R.C work and masonry walls to be tied with strap irons at every course

MECHANICAL

1. All Plumbing and Drainage Work to comply with specifications
2. S.V.P denotes soil vent pipe and to be provided at the head of the drainage
3. Where drainage is shown under driveways and slabs, to be encased in 150mm thick concrete surround.
4. All underground foul and waste drain pipes shall be of PVC to comply with BS5255
5. All ICs within building area driveway and parking to have heavy duty, double-seal airtight covers and walls to be 200mm.
6. Minimum slope in the drain pipes to be 1%
7. No chases for pipes will be allowed in the slabs
8. Sleeves will be allowed with written approval from S.E.
9. No cutting of concrete without express approval of the Architect or S.E
10. All testing of pipes must be coordinated with electrical and any conflicts must be resolved before works begin
11. Permanent vents denoted as P.V to be provided as shown on plan.

ELECTRICAL

All conduits must be laid before plastering

PROJECT:

PROPOSED STUDENT HOUSING FOR ALUPE UNIVERSITY

CLIENT:

Name: STATE DEPARTMENT FOR HOUSING AND URBAN DEVELOPMENT

Signature: _____ Date: _____

DRAWING TITLE:
ELEVATION 04

SCALE:
1:100

DRAWN BY:

CHECKED BY:

Name: _____
Signature: _____ Date: _____

DATE:

MINISTRY OF LANDS, PUBLIC WORKS, HOUSING AND URBAN DEVELOPMENT

STATE DEPARTMENT FOR HOUSING & URBAN DEVELOPMENT



FOR THE GOVERNMENT OF THE REPUBLIC OF KENYA

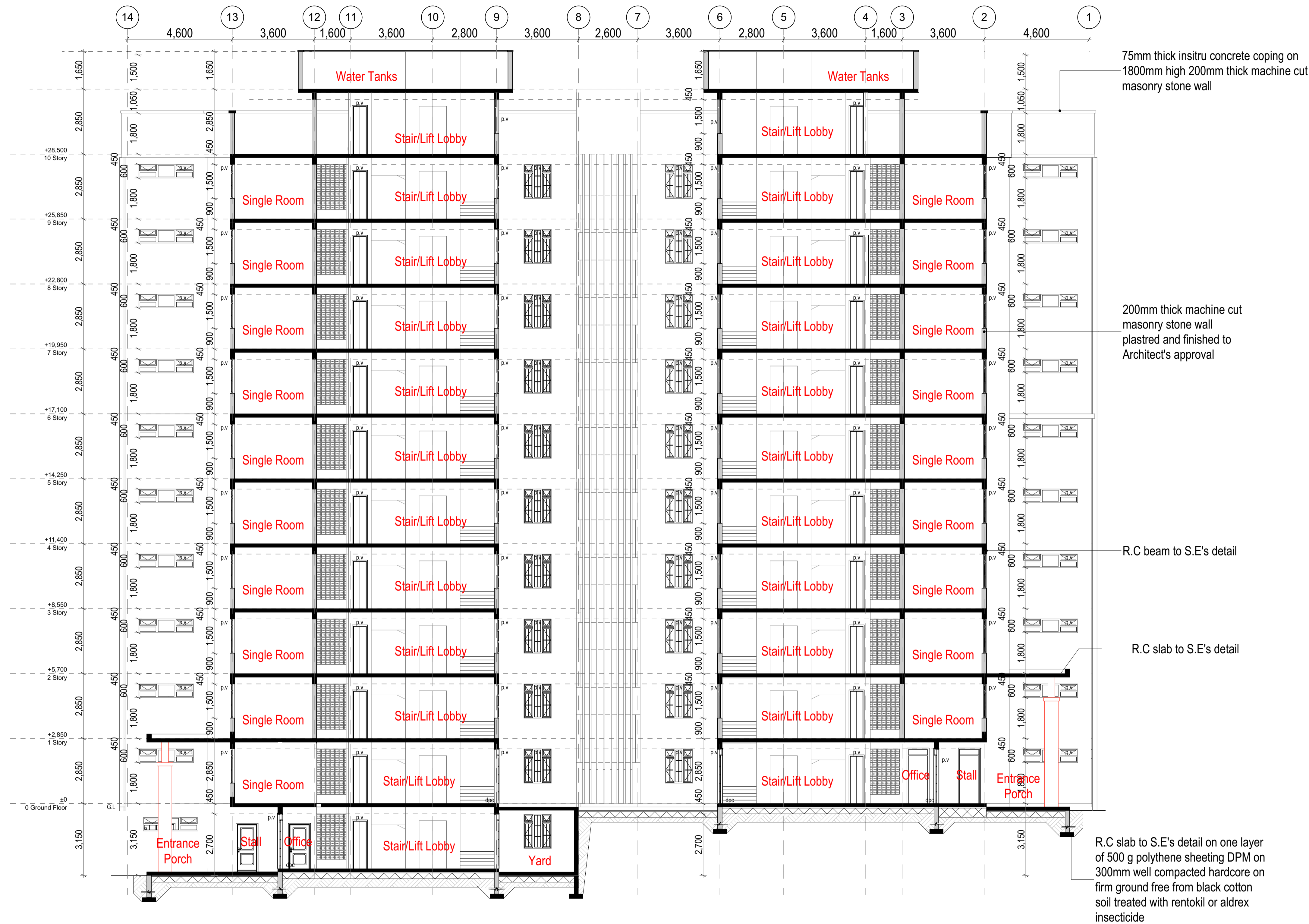

SECTION 01

GENERAL NOTES

1. This drawing to be read in conjunction with Engineers' drawings.
2. All dimensions are in mm unless otherwise specified.
3. Drawings are not to be scaled. Only figured dimensions should be used.
4. The contractor must check and verify all dimensions before commencement of work and if necessary confirm with the architect.

CONSTRUCTION

Approved anti-termite treatment & 1000 gauge polythene sheeting cover to be provided under all ground floor concrete slab on compacted hardcore to approval.
DPC to be 3ply bituminous felt to be provided under all walls.

STRUCTURAL

1. All Black cotton soil to be removed from below all building and paved surfaces
2. All reinforced concrete work will be in accordance with structural drawings.
3. Foundation depths to be determined on site to S.E approval
4. All walls less than 200mm thick to be reinforced with hoop iron at every alternate course.
5. All adjacent R.C work and masonry walls to be tied with strap irons at every course

MECHANICAL

1. All Plumbing and Drainage Work to comply with specifications
2. S.V.P denotes soil vent pipe and to be provided at the head of the drainage
3. Where drainage is shown under driveways and slabs, to be encased in 150mm thick concrete surround.
4. All underground foul and waste drain pipes shall be of PVC to comply with BS5255
5. All ICs within building area driveway and parking to have heavy duty, double-seal airtight covers and walls to be 200mm.
6. Minimum slope in the drain pipes to be 1%
7. No chases for pipes will be allowed in the slabs
8. Sleeves will be allowed with written approval from S.E.
9. No cutting of concrete without express approval of the Architect or S.E
10. All testing of pipes must be coordinated with electrical and any conflicts must be resolved before works begin
11. Permanent vents denoted as P.V to be provided as shown on plan.

ELECTRICAL

All conduits must be laid before plastering

PROJECT:

PROPOSED STUDENT HOUSING FOR ALUPE UNIVERSITY

CLIENT:

Name: STATE DEPARTMENT FOR HOUSING AND URBAN DEVELOPMENT

Signature: _____ Date: _____

DRAWING TITLE: SECTION 01

SCALE:

1:100

DRAWN BY:

CHECKED BY:

Name: _____

Signature: _____ Date: _____

DATE:

MINISTRY OF LANDS, PUBLIC WORKS,
HOUSING AND URBAN DEVELOPMENT

STATE DEPARTMENT FOR HOUSING & URBAN DEVELOPMENT



FOR THE GOVERNMENT OF THE
REPUBLIC OF KENYA

GENERAL NOTES

1. This drawing to be read in conjunction with Engineers' drawings.
2. All dimensions are in mm unless otherwise specified.
3. Drawings are not to be scaled. Only figured dimensions should be used.
4. The contractor must check and verify all dimensions before commencement of work and if necessary confirm with the architect.

CONSTRUCTION

Approved anti-termite treatment & 1000 gauge polythene sheeting cover to be provided under all ground floor concrete slab on compacted hardcore to approval.
DPC to be 3ply bituminous felt to be provided under all walls.

STRUCTURAL

1. All Black cotton soil to be removed from below all building and paved surfaces
2. All reinforced concrete work will be in accordance with structural drawings.
3. Foundation depths to be determined on site to S.E approval
4. All walls less than 200mm thick to be reinforced with hoop iron at every alternate course.
5. All adjacent R.C work and masonry walls to be tied with strap irons at every course

MECHANICAL

1. All Plumbing and Drainage Work to comply with specifications
2. S.V.P denotes soil vent pipe and to be provided at the head of the drainage
3. Where drainage is shown under driveways and slabs, to be encased in 150mm thick concrete surround.
4. All underground foul and waste drain pipes shall be of PVC to comply with BS5255
5. All ICs within building area driveway and parking to have heavy duty, double-seal airtight covers and walls to be 200mm.
6. Minimum slope in the drain pipes to be 1%
7. No chases for pipes will be allowed in the slabs
8. Sleeves will be allowed with written approval from S.E.
9. No cutting of concrete without express approval of the Architect or S.E
10. All testing of pipes must be coordinated with electrical and any conflicts must be resolved before works begin
11. Permanent vents denoted as P.V to be provided as shown on plan.

ELECTRICAL

All conduits must be laid before plastering

PROJECT:

PROPOSED STUDENT HOUSING FOR ALUPE UNIVERSITY

CLIENT:

Name: STATE DEPARTMENT FOR HOUSING AND URBAN DEVELOPMENT

Signature: _____ Date: _____

DRAWING TITLE:
SECTION 02

SCALE:
1:100

DRAWN BY:

CHECKED BY:

Name: _____

Signature: _____ Date: _____

DATE:

MINISTRY OF LANDS, PUBLIC WORKS, HOUSING AND URBAN DEVELOPMENT

STATE DEPARTMENT FOR HOUSING & URBAN DEVELOPMENT



FOR THE GOVERNMENT OF THE REPUBLIC OF KENYA

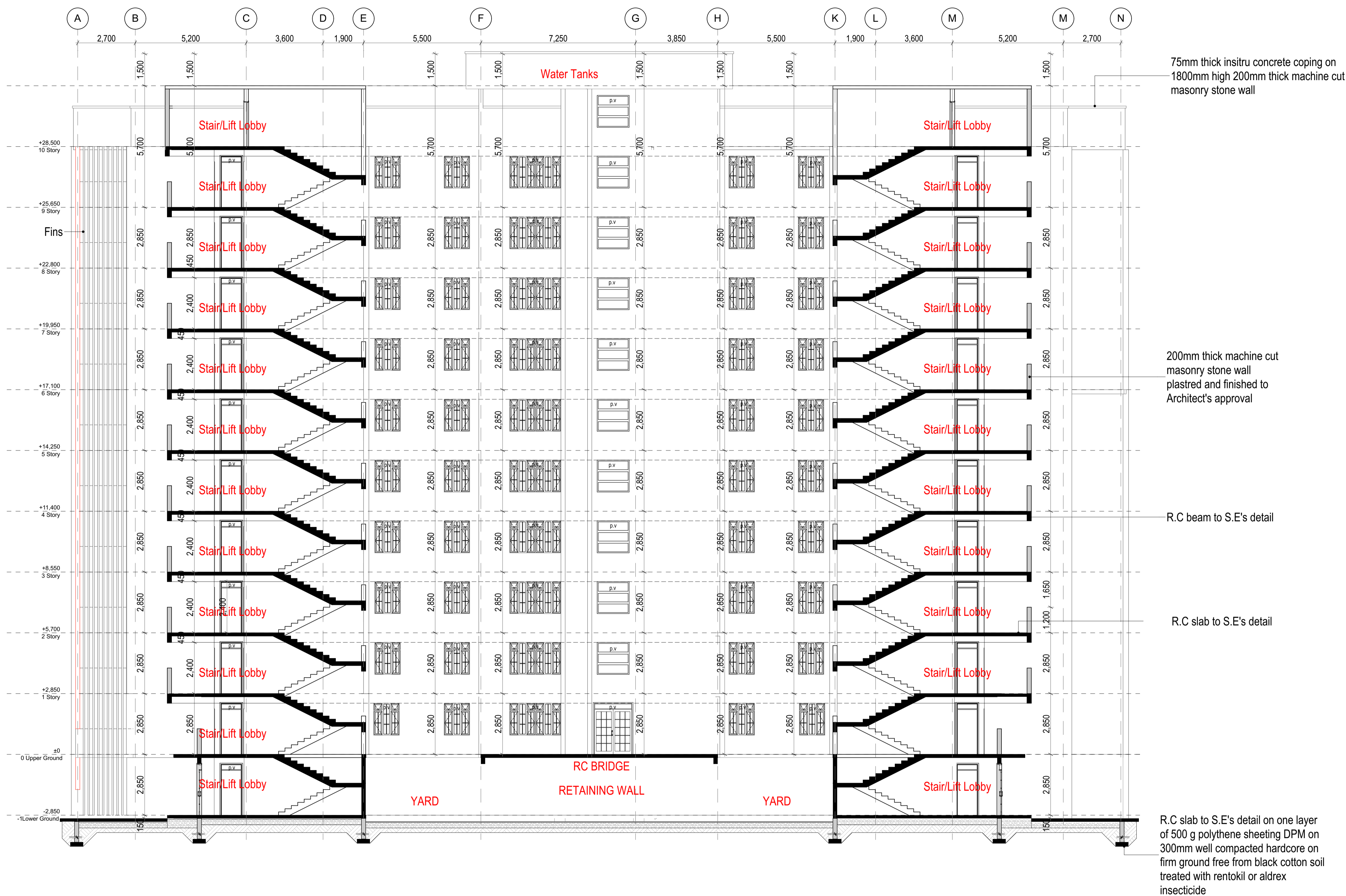

SECTION 02

3DVVISUALIZATION

STUDENT HOUSING

GENERAL NOTES

- 1. This drawing to be read in conjunction with Engineers' drawings.
- 2. All dimensions are in mm unless otherwise specified.
- 3. Drawings are not to be scaled. Only figured dimensions should be used.
- 4. The contractor must check and verify all dimensions before commencement of work and if necessary confirm with the architect.

CONSTRUCTION

Approved anti-termite treatment & 1000 gauge polythene sheeting cover to be provided under all ground floor concrete slab on compacted hardcore to approval.
DPC to be 3ply bituminous felt to be provided under all walls.

STRUCTURAL

- 1. All Black cotton soil to be removed from below all building and paved surfaces
- 2. All reinforced concrete work will be in accordance with structural drawings.
- 3. Foundation depths to be determined on site to S.E approval
- 4. All walls less than 200mm thick to be reinforced with hoop iron at every alternate course.
- 5. All adjacent R.C work and masonry walls to be tied with strap irons at every course

MECHANICAL

- 1. All Plumbing and Drainage Work to comply with specifications
- 2. S.V.P denotes soil vent pipe and to be provided at the head of the drainage
- 3. Where drainage is shown under driveways and slabs, to be encased in 150mm thick concrete surround.
- 4. All underground foul and waste drain pipes shall be of PVC to comply with BS5255
- 5. All ICs within building area, driveway and parking to have heavy duty, double-seal airtight covers and walls to be 200mm.
- 6. Minimum slope in the drain pipes to be 1%
- 7. No chases for pipes will be allowed in the slabs
- 8. Sleeves will be allowed with written approval from S.E.
- 9. No cutting of concrete without express approval of the Architect or S.E
- 10. All testing of pipes must be coordinated with electrical and any conflicts must be resolved before works begin
- 11. Permanent vents denoted as P.V to be provided as shown on plan.

ELECTRICAL

All conduits must be laid before plastering

PROJECT:

PROPOSED STUDENT HOUSING FOR ALUPE UNIVERSITY

CLIENT:

Name: STATE DEPARTMENT FOR HOUSING AND URBAN DEVELOPMENT

Signature: _____ Date: _____

DRAWING TITLE:

SCALE:

DRAWN BY:

CHECKED BY:

Name: _____

Signature: _____ Date: _____

DATE:

MINISTRY OF LANDS, PUBLIC WORKS, HOUSING AND URBAN DEVELOPMENT

STATE DEPARTMENT FOR HOUSING & URBAN DEVELOPMENT



FOR THE GOVERNMENT OF THE REPUBLIC OF KENYA



GENERAL NOTES

1. This drawing to be read in conjunction with Engineers' drawings.
2. All dimensions are in mm unless otherwise specified.
3. Drawings are not to be scaled. Only figured dimensions should be used.
4. The contractor must check and verify all dimensions before commencement of work and if necessary confirm with the architect.

CONSTRUCTION

Approved anti-termite treatment & 1000 gauge polythene sheeting cover to be provided under all ground floor concrete slab on compacted hardcore to approval.
DPC to be 3ply bituminous felt to be provided under all walls.

STRUCTURAL

1. All Black cotton soil to be removed from below all building and paved surfaces
2. All reinforced concrete work will be in accordance with structural drawings.
3. Foundation depths to be determined on site to S.E approval
4. All walls less than 200mm thick to be reinforced with hoop iron at every alternate course.
5. All adjacent R.C work and masonry walls to be tied with strap irons at every course

MECHANICAL

1. All Plumbing and Drainage Work to comply with specifications
2. S.V.P denotes soil vent pipe and to be provided at the head of the drainage
3. Where drainage is shown under driveways and slabs, to be encased in 150mm thick concrete surround.
4. All underground foul and waste drain pipes shall be of PVC to comply with BS5255
5. All ICs within building area, driveway and parking to have heavy duty, double-seal airtight covers and walls to be 200mm.
6. Minimum slope in the drain pipes to be 1%
7. No chases for pipes will be allowed in the slabs
8. Sleeves will be allowed with written approval from S.E.
9. No cutting of concrete without express approval of the Architect or S.E
10. All testing of pipes must be coordinated with electrical and any conflicts must be resolved before works begin
11. Permanent vents denoted as P.V to be provided as shown on plan.

ELECTRICAL

All conduits must be laid before plastering

PROJECT:

PROPOSED STUDENT HOUSING FOR ALUPE UNIVERSITY

CLIENT:

Name: STATE DEPARTMENT FOR HOUSING AND URBAN DEVELOPMENT

Signature: _____ Date: _____

DRAWING TITLE:

SCALE:

DRAWN BY:

CHECKED BY:

Name: _____

Signature: _____ Date: _____

DATE:

MINISTRY OF LANDS, PUBLIC WORKS, HOUSING AND URBAN DEVELOPMENT

STATE DEPARTMENT FOR HOUSING & URBAN DEVELOPMENT



FOR THE GOVERNMENT OF THE
REPUBLIC OF KENYA



GENERAL NOTES

1. This drawing to be read in conjunction with Engineers' drawings.
2. All dimensions are in mm unless otherwise specified.
3. Drawings are not to be scaled. Only figured dimensions should be used.
4. The contractor must check and verify all dimensions before commencement of work and if necessary confirm with the architect.

CONSTRUCTION

Approved anti-termite treatment & 1000 gauge polythene sheeting cover to be provided under all ground floor concrete slab on compacted hardcore to approval.
DPC to be 3ply bituminous felt to be provided under all walls.

STRUCTURAL

1. All Black cotton soil to be removed from below all building and paved surfaces
2. All reinforced concrete work will be in accordance with structural drawings.
3. Foundation depths to be determined on site to S.E approval
4. All walls less than 200mm thick to be reinforced with hoop iron at every alternate course.
5. All adjacent R.C work and masonry walls to be tied with strap irons at every course

MECHANICAL

1. All Plumbing and Drainage Work to comply with specifications
2. S.V.P denotes soil vent pipe and to be provided at the head of the drainage
3. Where drainage is shown under driveways and slabs, to be encased in 150mm thick concrete surround.
4. All underground foul and waste drain pipes shall be of PVC to comply with BS5255
5. All ICs within building area, driveway and parking to have heavy duty, double-seal airtight covers and walls to be 200mm.
6. Minimum slope in the drain pipes to be 1%
7. No chases for pipes will be allowed in the slabs
8. Sleeves will be allowed with written approval from S.E.
9. No cutting of concrete without express approval of the Architect or S.E
10. All testing of pipes must be coordinated with electrical and any conflicts must be resolved before works begin
11. Permanent vents denoted as P.V to be provided as shown on plan.

ELECTRICAL

All conduits must be laid before plastering

PROJECT:

PROPOSED STUDENT HOUSING FOR ALUPE UNIVERSITY

CLIENT:

Name: STATE DEPARTMENT FOR HOUSING AND URBAN DEVELOPMENT

Signature: _____ Date: _____

DRAWING TITLE:

SCALE:

DRAWN BY:

CHECKED BY:

Name: _____

Signature: _____ Date: _____

DATE:

MINISTRY OF LANDS, PUBLIC WORKS, HOUSING AND URBAN DEVELOPMENT

STATE DEPARTMENT FOR HOUSING & URBAN DEVELOPMENT



FOR THE GOVERNMENT OF THE
REPUBLIC OF KENYA



OPENING SCHEDULES

STUDENT HOUSING

GENERAL NOTES

1. This drawing to be read in conjunction with Engineers' drawings.
2. All dimensions are in mm unless otherwise specified.
3. Drawings are not to be scaled. Only figured dimensions should be used.
4. The contractor must check and verify all dimensions before commencement of work and if necessary confirm with the architect.

CONSTRUCTION

Approved anti-termite treatment & 1000 gauge polythene sheeting cover to be provided under all ground floor concrete slab on compacted hardcore to approval.
DPC to be 3ply bituminous felt to be provided under all walls.

STRUCTURAL

1. All Black cotton soil to be removed from below all building and paved surfaces
2. All reinforced concrete work will be in accordance with structural drawings.
3. Foundation depths to be determined on site to S.E approval
4. All walls less than 200mm thick to be reinforced with hoop iron at every alternate course.
5. All adjacent R.C work and masonry walls to be tied with strap irons at every course

MECHANICAL

1. All Plumbing and Drainage Work to comply with specifications
2. S.V.P denotes soil vent pipe and to be provided at the head of the drainage
3. Where drainage is shown under driveways and slabs, to be encased in 150mm thick concrete surround.
4. All underground foul and waste drain pipes shall be of PVC to comply with BS 5255
5. All ICs within building area, driveway and parking to have heavy duty, double-seal airtight covers and walls to be 200mm.
6. Minimum slope in the drain pipes to be 1%
7. No chases for pipes will be allowed in the slabs
8. Sleeves will be allowed with written approval from S.E.
9. No cutting of concrete without express approval of the Architect or S.E
10. All testing of pipes must be coordinated with electrical and any conflicts must be resolved before works begin
11. Permanent vents denoted as P.V to be provided as shown on plan.

ELECTRICAL

All conduits must be laid before plastering

PROJECT:

PROPOSED STUDENT HOUSING FOR ALUPE UNIVERSITY

CLIENT:

Name: STATE DEPARTMENT FOR HOUSING AND URBAN DEVELOPMENT

Signature: _____ Date: _____

DRAWING TITLE:

GROUND FLOOR OPENINGS PLAN

SCALE:

DRAWN BY: ARCH JMO

CHECKED BY:

Name: _____

Signature: _____ Date: _____

DATE:

MINISTRY OF LANDS, PUBLIC WORKS, HOUSING AND URBAN DEVELOPMENT
STATE DEPARTMENT FOR HOUSING & URBAN DEVELOPMENT



FOR THE GOVERNMENT OF THE REPUBLIC OF KENYA

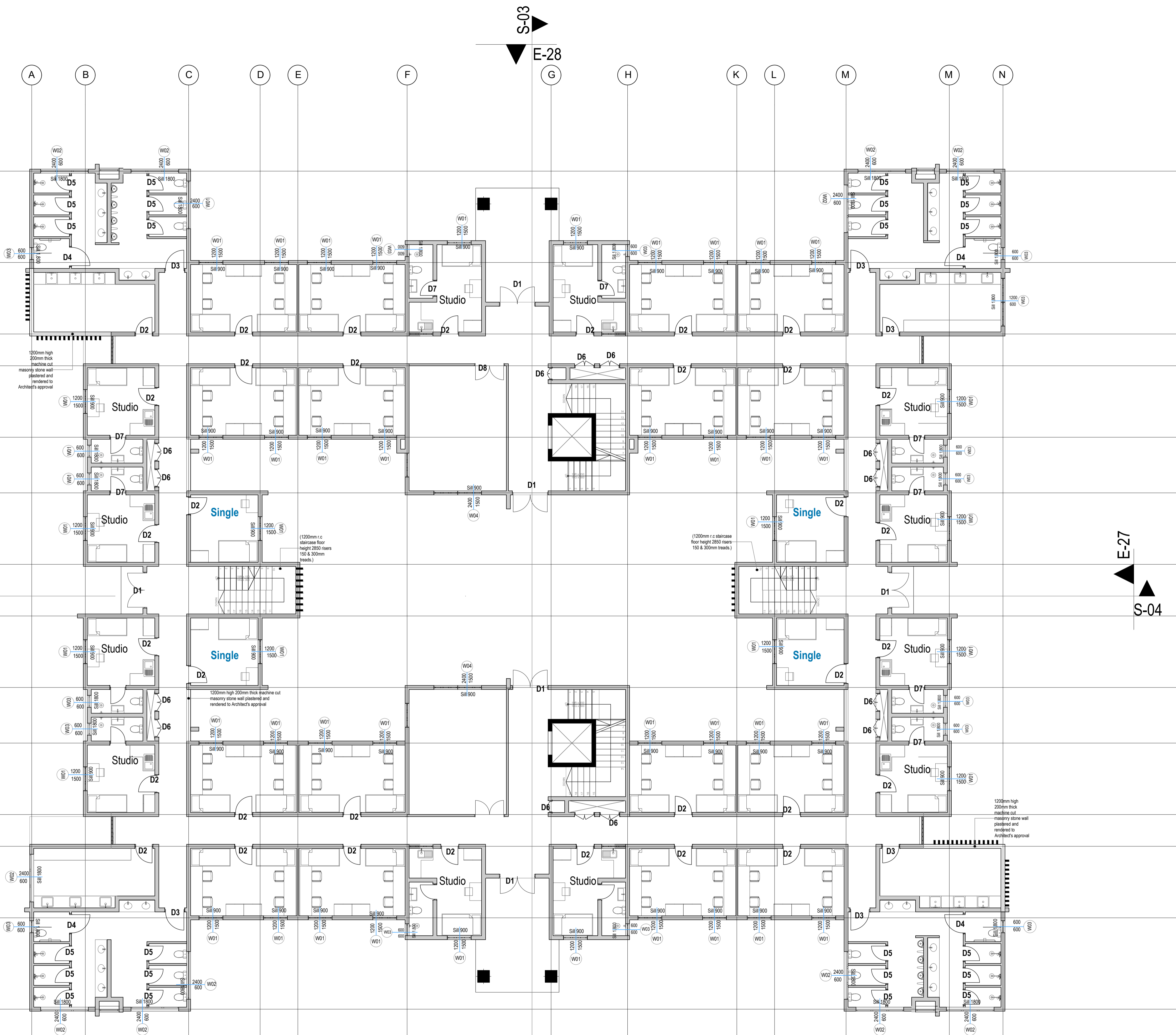

GROUND FLOOR PLAN -OPENING SCHEDULE LAYOUT

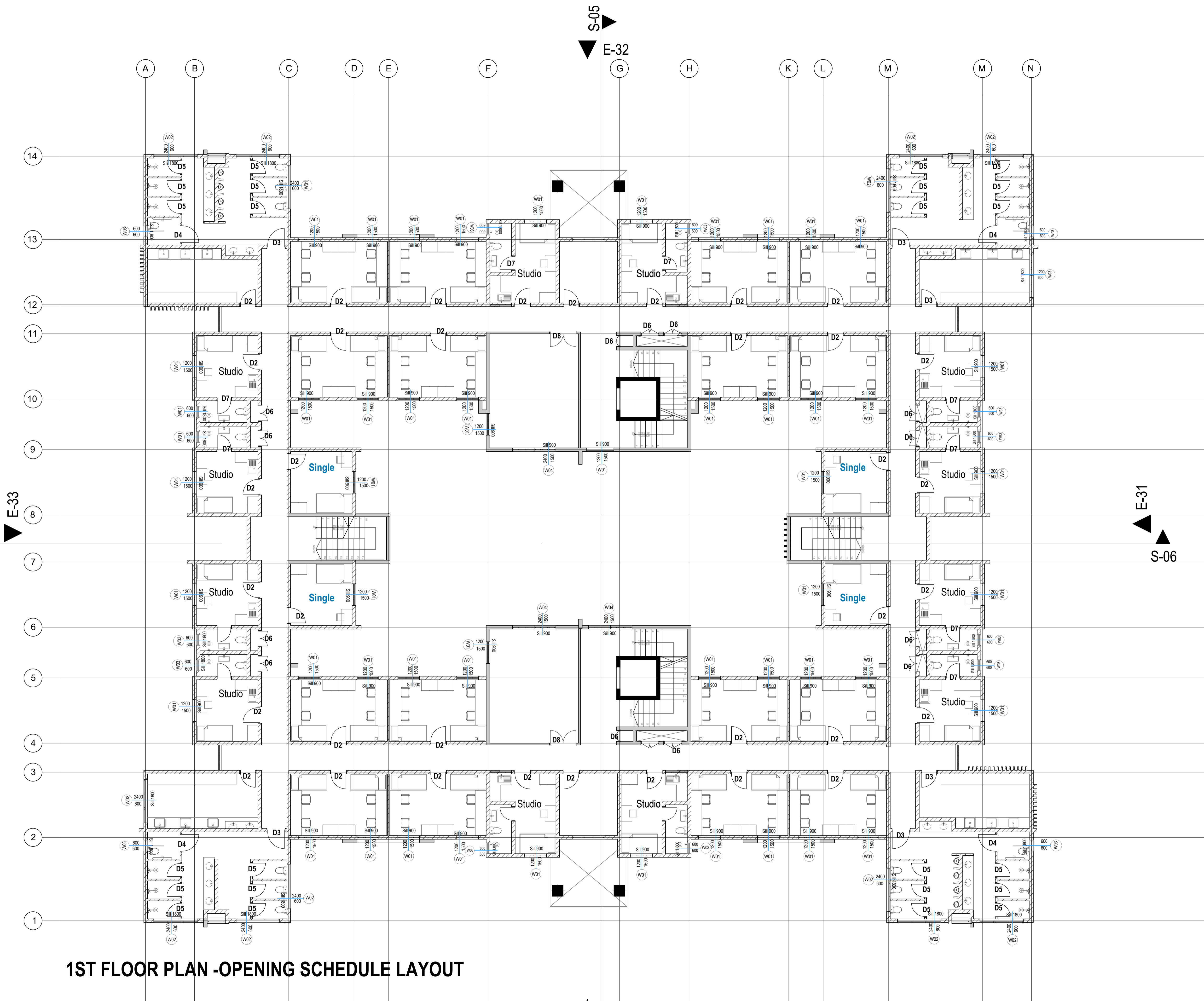

1ST FLOOR PLAN -OPENING SCHEDULE LAYOUT

GENERAL NOTES

1. This drawing to be read in conjunction with Engineers' drawings.
2. All dimensions are in mm unless otherwise specified.
3. Drawings are not to be scaled. Only figured dimensions should be used.
4. The contractor must check and verify all dimensions before commencement of work and if necessary confirm with the architect.

CONSTRUCTION

Approved anti-termite treatment & 1000 gauge polythene sheeting cover to be provided under all ground floor concrete slab on compacted hardcore to approval.
DPC to be 3ply bituminous felt to be provided under all walls.

STRUCTURAL

1. All Black cotton soil to be removed from below all building and paved surfaces
2. All reinforced concrete work will be in accordance with structural drawings.
3. Foundation depths to be determined on site to S.E approval
4. All walls less than 200mm thick to be reinforced with hoop iron at every alternate course.
5. All adjacent R.C work and masonry walls to be tied with strap irons at every course

MECHANICAL

1. All Plumbing and Drainage Work to comply with specifications
2. S.V.P denotes soil vent pipe and to be provided at the head of the drainage
3. Where drainage is shown under driveways and slabs, to be encased in 150mm thick concrete surround.
4. All underground foul and waste drain pipes shall be of PVC to comply with BS 5255
5. All ICs within building area, driveway and parking to have heavy duty, double-seal airtight covers and walls to be 200mm.
6. Minimum slope in the drain pipes to be 1%
7. No chases for pipes will be allowed in the slabs
8. Sleeves will be allowed with written approval from S.E.
9. No cutting of concrete without express approval of the Architect or S.E
10. All testing of pipes must be coordinated with electrical and any conflicts must be resolved before works begin
11. Permanent vents denoted as P.V to be provided as shown on plan.

ELECTRICAL

All conduits must be laid before plastering

PROJECT:

PROPOSED STUDENT HOUSING FOR ALUPE UNIVERSITY

CLIENT:

Name: STATE DEPARTMENT FOR HOUSING AND URBAN DEVELOPMENT

Signature: _____ Date: _____

DRAWING TITLE:

1ST FLOOR OPENINGS PLAN

SCALE:

DRAWN BY: ARCH JMO

CHECKED BY:

Name: _____

Signature: _____ Date: _____

DATE:

MINISTRY OF LANDS, PUBLIC WORKS, HOUSING AND URBAN DEVELOPMENT
STATE DEPARTMENT FOR HOUSING & URBAN DEVELOPMENT

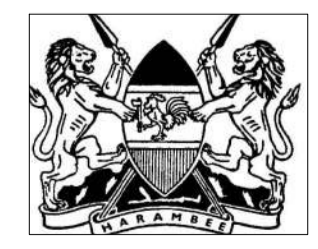

FOR THE GOVERNMENT OF THE REPUBLIC OF KENYA

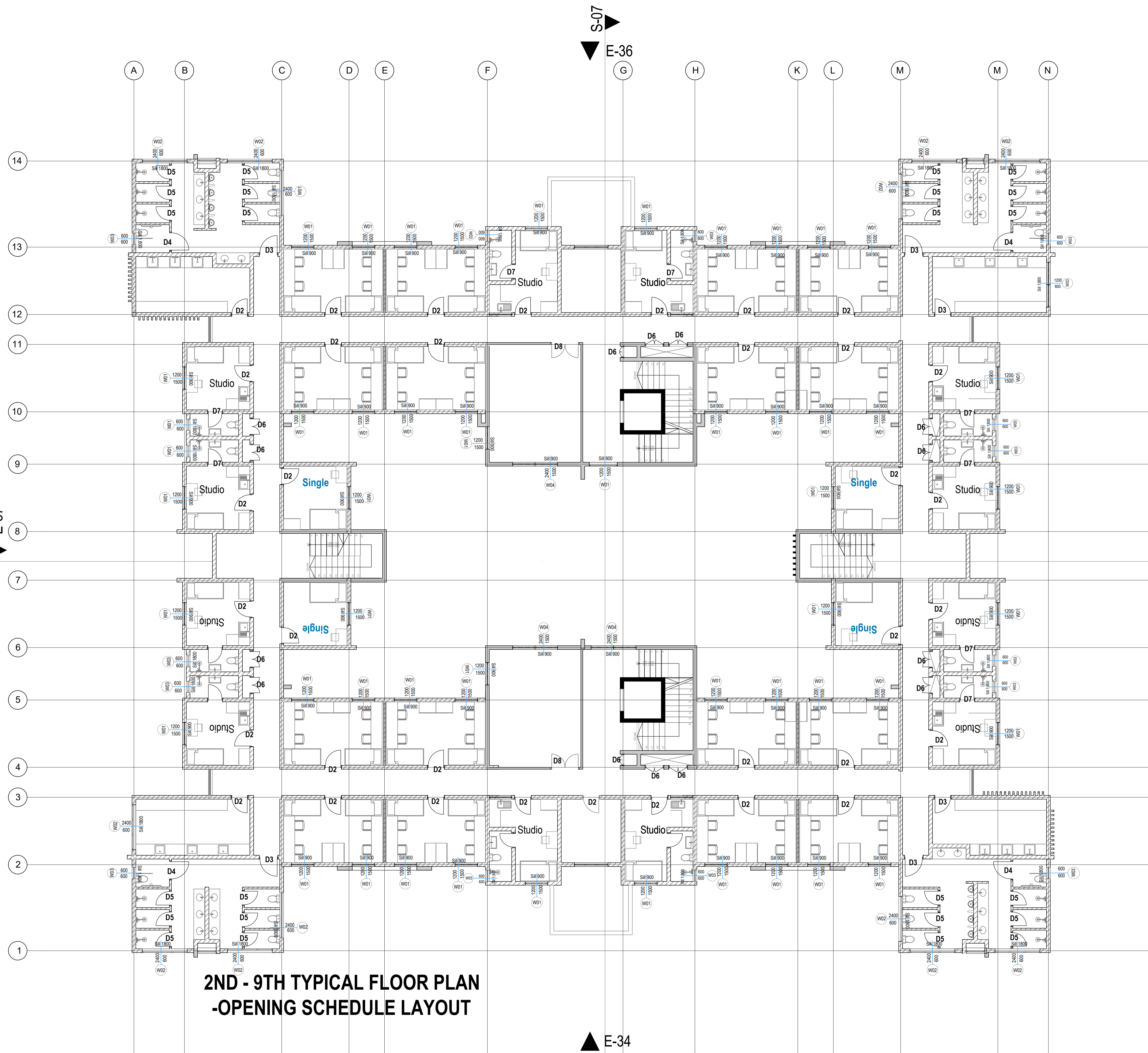

**2ND - 9TH TYPICAL FLOOR PLAN
-OPENING SCHEDULE LAYOUT**

GENERAL NOTES

1. This drawing to be read in conjunction with Engineers' drawings.
2. All dimensions are in mm unless otherwise specified.
3. Drawings are not to be scaled. Only figured dimensions should be used.
4. The contractor must check and verify all dimensions before commencement of work and if necessary confirm with the architect.

CONSTRUCTION

Approved anti-termite treatment & 1000 gauge polythene sheeting cover to be provided under all ground floor concrete slab on compacted hardcore to approval.
DPC to be 3ply bituminous felt to be provided under all walls.

STRUCTURAL

1. All Black cotton soil to be removed from below all building and paved surfaces
2. All reinforced concrete work will be in accordance with structural drawings.
3. Foundation depths to be determined on site to S.E approval
4. All walls less than 200mm thick to be reinforced with hoop iron at every alternate course.
5. All adjacent R.C work and masonry walls to be tied with strap irons at every course

MECHANICAL

1. All Plumbing and Drainage Work to comply with specifications
2. S.V.P denotes soil vent pipe and to be provided at the head of the drainage
3. Where drainage is shown under driveways and slabs, to be encased in 150mm thick concrete surround.
4. All underground foul and waste drain pipes shall be of PVC to comply with BS 5255
5. All ICs within building area, driveway and parking to have heavy duty, double-seal airtight covers and walls to be 200mm.
6. Minimum slope in the drain pipes to be 1%
7. No chases for pipes will be allowed in the slabs
8. Sleeves will be allowed with written approval from S.E.
9. No cutting of concrete without express approval of the Architect or S.E
10. All testing of pipes must be coordinated with electrical and any conflicts must be resolved before works begin
11. Permanent vents denoted as P.V to be provided as shown on plan.

ELECTRICAL

All conduits must be laid before plastering

PROJECT:

PROPOSED STUDENT HOUSING FOR ALUPE UNIVERSITY

CLIENT:

Name: STATE DEPARTMENT FOR HOUSING AND URBAN DEVELOPMENT

Signature: _____ Date: _____

DRAWING TITLE:

2ND -9TH FLOOR OPENINGS PLAN

SCALE:

AS SHOWN

DRAWN BY: ARCH JMO

Signature: _____ Date: _____

CHECKED BY:

Name: _____

Signature: _____ Date: _____

DATE:

MINISTRY OF LANDS, PUBLIC WORKS, HOUSING AND URBAN DEVELOPMENT
STATE DEPARTMENT FOR HOUSING & URBAN DEVELOPMENT

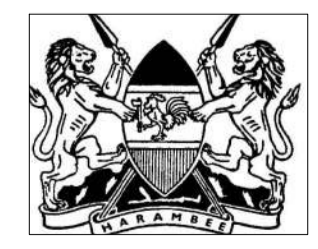

FOR THE GOVERNMENT OF THE REPUBLIC OF KENYA

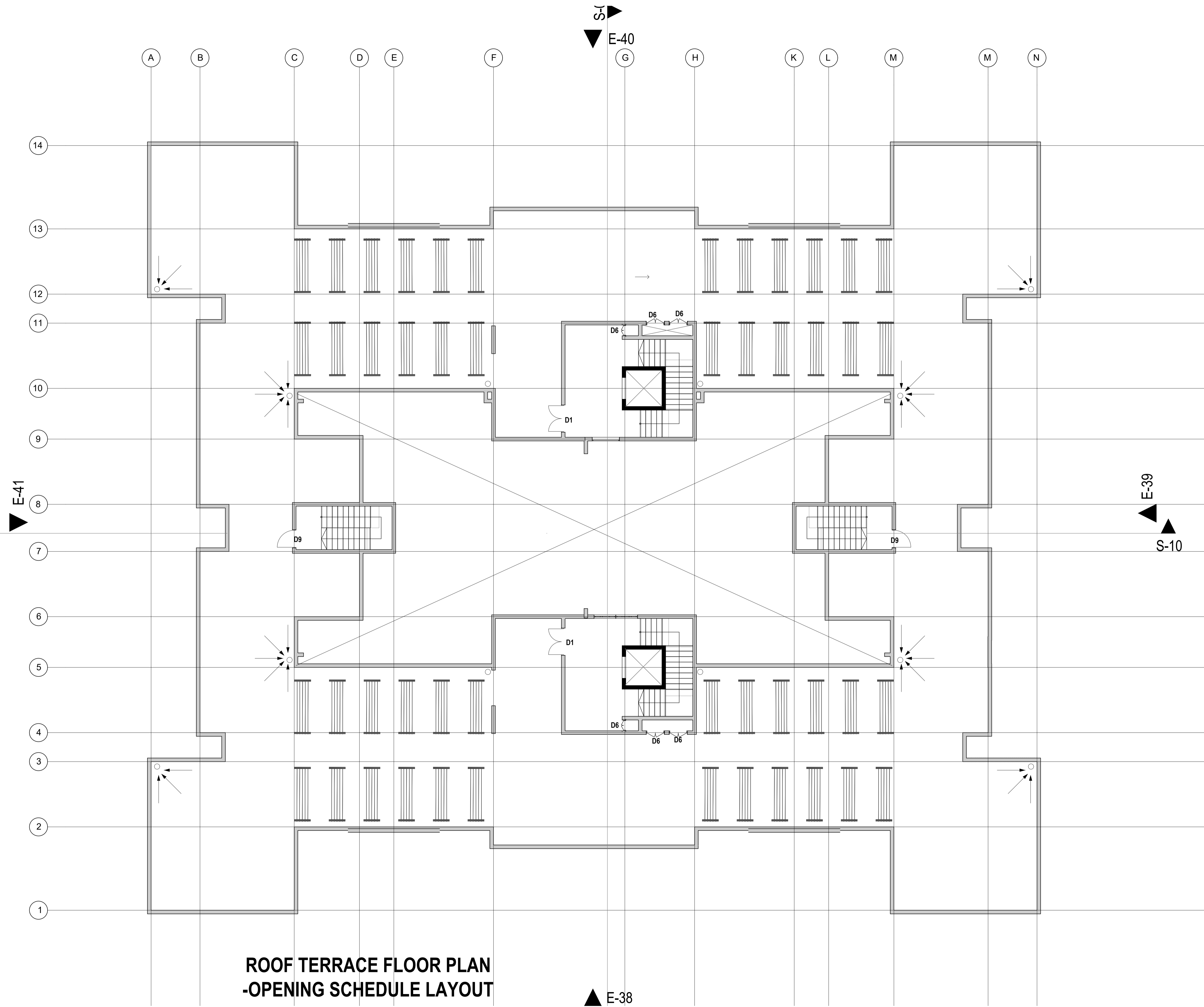

**ROOF TERRACE FLOOR PLAN
-OPENING SCHEDULE LAYOUT**

GENERAL NOTES

1. This drawing to be read in conjunction with Engineers' drawings.
2. All dimensions are in mm unless otherwise specified.
3. Drawings are not to be scaled. Only figured dimensions should be used.
4. The contractor must check and verify all dimensions before commencement of work and if necessary confirm with the architect.

CONSTRUCTION

Approved anti-termite treatment & 1000 gauge polythene sheeting cover to be provided under all ground floor concrete slab on compacted hardcore to approval.
DPC to be 3ply bituminous felt to be provided under all walls.

STRUCTURAL

1. All Black cotton soil to be removed from below all building and paved surfaces
2. All reinforced concrete work will be in accordance with structural drawings.
3. Foundation depths to be determined on site to S.E approval
4. All walls less than 200mm thick to be reinforced with hoop iron at every alternate course.
5. All adjacent R.C work and masonry walls to be tied with strap iron at every course

MECHANICAL

1. All Plumbing and Drainage Work to comply with specifications
2. S.V.P denotes soil vent pipe and to be provided at the head of the drainage
3. Where drainage is shown under driveways and slabs, to be encased in 150mm thick concrete surround.
4. All underground foul and waste drain pipes shall be of PVC to comply with BS 5255
5. All ICS within building area, driveway and parking to have heavy duty, double-seal airtight covers and walls to be 200mm.
6. Minimum slope in the drain pipes to be 1%
7. No chases for pipes will be allowed in the slabs
8. Sleeves will be allowed with written approval from S.E.
9. No cutting of concrete without express approval of the Architect or S.E
10. All testing of pipes must be coordinated with electrical and any conflicts must be resolved before works begin
11. Permanent vents denoted as P.V to be provided as shown on plan.

ELECTRICAL

All conduits must be laid before plastering

PROJECT:

PROPOSED STUDENT HOUSING FOR ALUPE UNIVERSITY

CLIENT:

Name: STATE DEPARTMENT FOR HOUSING AND URBAN DEVELOPMENT

Signature: _____ Date: _____

DRAWING TITLE:

ROOF TERRACE OPENINGS PLAN

SCALE:

DRAWN BY: ARCH JMO

CHECKED BY:

Name: _____

Signature: _____ Date: _____

DATE:

MINISTRY OF LANDS, PUBLIC WORKS, HOUSING AND URBAN DEVELOPMENT
STATE DEPARTMENT FOR HOUSING & URBAN DEVELOPMENT



FOR THE GOVERNMENT OF THE
REPUBLIC OF KENYA

DOOR DESCRIPTION:	
EXTERNAL ELEVATION:	
INTERNAL ELEVATION:	
INTERNAL ELEVATION:	
OPENING IDENTIFICATION:	D 1
QUANTITY:	PER FLOOR: 4 at round floor & 2 at Roof top
	TOTAL NO.: 6
LOCATION: GROUND FLOOR & FLOORS 1-9	*Main Entrances & Roof top
Performance Class	*Steel Door double leaf & single swing door
Opening size:	*1800x2400mm plaster to plaster opening
Door frame:	*50mmx50mm mild steel RHS section fishtailed & lugged into the wall on 3 sides
Architrave:	Nil
Door leaf:	Leaf size: 2 number 850 x 2100mm high steel door leafs Leaf frame: 40x40x2mm main frames all round with 25x25x3mm Tees to carry glass Material: Still & fixed 4mm clear glass Appearance: Flush panels to both sides - Painted. Finish: 1 coat Steel primer paint with 2 coat gloss paint
Fan light	*900mmx 300mm fanlight in 4mm thick clear glazing fixed above door
Ironmongery:	Hinge: Parliament m.s steel hinges opening 180 degrees Lock: *2 Lever mortice lock of approved quality Handle: Keyed entry handles of approved quality
Finishing:	One coat of paint on one coat of wood primer
Signage:	Stainless steel door sign with door numbers

DOOR DESCRIPTION:	
EXTERNAL ELEVATION:	
INTERNAL ELEVATION:	
INTERNAL ELEVATION:	
OPENING IDENTIFICATION:	D 2
QUANTITY:	PER FLOOR: 32
	TOTAL NO.: 320
LOCATION: GROUND FLOOR & FLOORS 1-9	*Quad Bed Rooms, Studio & Single
Performance Class	*Flush Timber Single leaf & single swing door
Opening:	*1000x2400mm plaster to plaster opening
Door frame:	*50mmx150mm softwood timber rebated fixed plugged & screwed into walls
Architrave:	Ex25x50mm architraves all round all sides with 25x25mm quadrant beading
Door leaf:	Leaf size: 1 No size 900 x 2100mm x 50mm thick semi solid core flush door plywood finished for painting to both sides with 15mm thick wood lipping all round Leaf frame: softwood timber treated & braced Material: Semi Solid core timber infill Appearance: Flush panels to both sides - Painted. Finish: Plywood with hard wood edges finished for painting
Fan light	*900mmx 300mm fanlight in 4mm thick clear glazing fixed above door
Ironmongery:	Hinge: *1 1/2 pairs of 100mm pressed steel but hinges Lock: *2 Lever mortice lock of approved quality Handle: Keyed entry handles of approved quality
Finishing:	One coat of paint on one coat of wood primer
Signage:	Stainless steel door sign with door numbers

DOOR DESCRIPTION:	
EXTERNAL ELEVATION:	
INTERNAL ELEVATION:	
INTERNAL ELEVATION:	
OPENING IDENTIFICATION:	D 3
QUANTITY:	PER FLOOR: 8
	TOTAL NO.: 80
LOCATION: GROUND FLOOR & FLOORS 1-9	*Washrooms, Wash up area & Shared Kitchen
Performance Class	*Flush Timber Single leaf & single swing door
Opening:	*1100x2400mm plaster to plaster opening
Door frame:	*50mmx150mm softwood timber rebated fixed plugged & screwed into walls
Architrave:	Ex25x50mm architraves all round all sides with 25x25mm quadrant beading
Door leaf:	Leaf size: 1 No size 900 x 2100mm x 50mm thick semi solid core flush door plywood finished for painting to both sides with 15mm thick wood lipping all round Leaf frame: softwood timber treated & braced Material: Semi Solid core timber infill Appearance: Flush panels to both sides - Painted. Finish: Plywood with hard wood edges finished for painting
Fan light	*1000mmx 300mm fanlight in 4mm thick clear glazing fixed above door
Ironmongery:	Hinge: *1 1/2 pairs of 100mm pressed steel but hinges Lock: *2 Lever mortice lock of approved quality Handle: Keyed entry handles of approved quality
Finishing:	One coat of paint on one coat of wood primer
Signage:	Stainless steel door sign with door numbers

DOOR DESCRIPTION:	
EXTERNAL ELEVATION:	
INTERNAL ELEVATION:	
INTERNAL ELEVATION:	
OPENING IDENTIFICATION:	D 4
QUANTITY:	PER FLOOR: 7
	TOTAL NO.: 70
LOCATION: GROUND FLOOR & FLOORS 1-9	*Washrooms
Performance Class	*Flush Timber Single leaf & single swing door
Opening:	*1100x1800mm plaster to plaster opening
Door frame:	*50mmx150mm softwood timber rebated fixed plugged & screwed into walls
Architrave:	Ex25x50mm architraves all round all sides with 25x25mm quadrant beading
Door leaf:	Leaf size: 1 No size 1000 x 1800mm x 50mm thick semi solid core flush door plywood finished for painting to both sides with 15mm thick wood lipping all round. Door leaf undercut by 50mm. Leaf frame: softwood timber treated & braced Material: Semi Solid core timber infill Appearance: Flush panels to both sides - Painted. Finish: Plywood with hard wood edges finished for painting
Fan light	*Nil
Ironmongery:	Hinge: *1 1/2 pairs of 100mm pressed steel but hinges Lock: *2 Lever mortice lock of approved quality Handle: Keyed entry handles of approved quality
Finishing:	One coat of paint on one coat of wood primer
Signage:	Stainless steel door sign with door numbers
Remarks:	Ironmongery and door sample to be provided for approval

DOOR DESCRIPTION:	
EXTERNAL ELEVATION:	
INTERNAL ELEVATION:	
INTERNAL ELEVATION:	
OPENING IDENTIFICATION:	D 5
QUANTITY:	PER FLOOR: 24
	TOTAL NO.: 240
LOCATION: GROUND FLOOR & FLOORS 1-9	Washroom cubicles
Performance Class	*Flush Timber Single leaf & single swing door
Opening:	*800x2400mm plaster to plaster opening
Door frame:	*50mmx150mm softwood timber rebated fixed plugged & screwed into walls
Architrave:	Ex25x50mm architraves all round all sides with 25x25mm quadrant beading
Door leaf:	Leaf size: 1 No size 700 x 1800mm x 50mm thick semi solid core flush door plywood finished for painting to both sides with 15mm thick wood lipping all round. Door Leaf undercut by 50mm. Leaf frame: softwood timber treated & braced Material: Semi Solid core timber infill Appearance: Flush panels to both sides - Painted. Finish: Plywood with hard wood edges finished for painting
Fan light	*Nil
Ironmongery:	Hinge: *1 1/2 pairs of 100mm pressed steel but hinges Lock: *2 Lever mortice lock of approved quality Handle: Keyed entry handles of approved quality
Finishing:	One coat of paint on one coat of wood primer
Signage:	Stainless steel door sign with door numbers
Remarks:	Ironmongery and door sample to be provided for approval

DOOR DESCRIPTION:	
EXTERNAL ELEVATION:	
INTERNAL ELEVATION:	
INTERNAL ELEVATION:	
OPENING IDENTIFICATION:	D 6
QUANTITY:	PER FLOOR: 12
	TOTAL NO.: 126
LOCATION: GROUND FLOOR & FLOORS 1-9	Ducts
Performance Class	*Flush Timber Single leaf & single swing door
Opening:	*800x2400mm plaster to plaster opening
Door frame:	*50mmx150mm softwood timber rebated fixed plugged & screwed into walls
Architrave:	Ex25x50mm architraves all round all sides with 25x25mm quadrant beading
Door leaf:	Leaf size: 2 No size 400 x 2050mm x 50mm thick semi solid core flush door plywood finished for painting to both sides with 15mm thick wood lipping all round. Duct edge upstand raised by 300mm. Leaf frame: softwood timber treated & braced Material: Semi Solid core timber infill Appearance: Flush panels to both sides - Painted. Finish: Plywood with hard wood edges finished for painting
Fan light	*Nil
Ironmongery:	Hinge: *3 pairs of 100mm pressed steel but hinges Lock: *2 Lever mortice lock of approved quality Handle: Keyed entry handles of approved quality
Finishing:	One coat of paint on one coat of wood primer
Signage:	Stainless steel door sign with door numbers
Remarks:	Ironmongery and door sample to be provided for approval

DOOR DESCRIPTION:	
EXTERNAL ELEVATION:	
INTERNAL ELEVATION:	
INTERNAL ELEVATION:	
OPENING IDENTIFICATION:	D 7
QUANTITY:	PER FLOOR: 12
	TOTAL NO.: 120
LOCATION: GROUND FLOOR & FLOORS 1-9	Studio WC/SH
Performance Class	*Flush Timber Single leaf & single swing door
Opening:	*800x2400mm plaster to plaster opening
Door frame:	*50mmx150mm softwood timber rebated fixed plugged & screwed into walls
Architrave:	Ex25x50mm architraves all round all sides with 25x25mm quadrant beading
Door leaf:	Leaf size: 1 No size 700 x 2100mm semi solid core flush door plywood finished for painting to both sides with 15mm thick wood lipping all round. Leaf frame: softwood timber treated & braced Material: Semi Solid core timber infill Appearance: Flush panels to both sides - Painted. Finish: Plywood with hard wood edges finished for painting
Fan light	*700mmx 300mm fanlight in 4mm thick clear glazing fixed above door
Ironmongery:	Hinge: *1 1/2 pairs of 100mm pressed steel but hinges Lock: *2 Lever mortice lock of approved quality Handle: Keyed entry handles of approved quality
Finishing:	One coat of paint on one coat of wood primer
Signage:	Stainless steel door sign with door numbers
Remarks:	Ironmongery and door sample to be provided for approval

DOOR DESCRIPTION:	
EXTERNAL ELEVATION:	
INTERNAL ELEVATION:	
INTERNAL ELEVATION:	
OPENING IDENTIFICATION:	D 8
QUANTITY:	PER FLOOR: 2
	TOTAL NO.: 18
LOCATION: GROUND FLOOR & FLOORS 1-9	Lounge
Performance Class	*Flush Timber Double leaf & single swing door
Opening:	*1500x2400mm plaster to plaster opening
Door frame:	*50mmx150mm softwood timber rebated fixed plugged & screwed into walls
Architrave:	Ex25x50mm architraves all round all sides with 25x25mm quadrant beading
Door leaf:	Leaf size: 2 No size 700 x 2100mm x 50mm thick semi solid core flush door plywood finished for painting to both sides with 15mm thick wood lipping all round. Leaves rebated. Leaf frame: softwood timber treated & braced Material: Semi Solid core timber infill Appearance: Flush panels to both sides - Painted. Finish: Plywood with hard wood edges finished for painting
Fan light	*900mmx 300mm fanlight in 4mm thick clear glazing fixed above door
Ironmongery:	Hinge: *3 pairs of 100mm pressed steel but hinges Lock: *2 Lever mortice lock of approved quality. Bolt to top frame and to floor for one leaf Handle: Keyed entry handles of approved quality
Finishing:	One coat of paint on one coat of wood primer
Signage:	Stainless steel door sign with door numbers
Remarks:	Ironmongery and door sample to be provided for approval

DOOR DESCRIPTION:	
EXTERNAL ELEVATION:	
INTERNAL ELEVATION:	
INTERNAL ELEVATION:	
OPENING IDENTIFICATION:	D9
QUANTITY:	PER FLOOR: Only at Roof top
	TOTAL NO.: 2
LOCATION: GROUND FLOOR & FLOORS 1-9	*Roof top
Performance Class	*Steel Door single leaf & single swing door
Opening size:	*1000x2400mm plaster to plaster opening
Door frame:	*50mmx50mm mild steel RHS section fishtailed & lugged into the wall on 3 sides
Architrave:	Nil
Door leaf:	Leaf size: 1 number single door 900 x 2100mm high steel door leaf Leaf frame: 40x40x2mm main frames all round with 25x25x3mm Tees to carry glass Material: Still & fixed 4mm clear glass Appearance: Flush panels to both sides - Painted. Finish: 1 coat Steel primer paint with 2 coat gloss paint
Fan light	*920mmx 300mm fanlight in 4mm thick clear glazing fixed above door
Ironmongery:	Hinge: Parliament m.s steel hinges opening 180 degrees Lock: *2 Lever mortice lock of approved quality Handle: Keyed entry handles of approved quality
Finishing:	One coat of paint on one coat of wood primer
Signage:	Stainless steel door sign with door numbers
Remarks:	Ironmongery and door sample to be provided for approval

GENERAL NOTES

1. This drawing to be read in conjunction with Engineers' drawings.
2. All dimensions are in mm unless otherwise specified.
3. Drawings are not to be scaled. Only figured dimensions should be used.
4. The contractor must check and verify all dimensions before commencement of work and if necessary confirm with the architect.

CONSTRUCTION

Approved anti-termite treatment & 1000 gauge polythene sheeting cover to be provided under all ground floor concrete slab on compacted hardcore to approval.
DPC to be 3ply bituminous felt to be provided under all walls.

STRUCTURAL

1. All Black cotton soil to be removed from below all building and paved surfaces
2. All reinforced concrete work will be in accordance with structural drawings.
3. Foundation depths to be determined on site to S.E approval
4. All walls less than 200mm thick to be reinforced with hoop iron at every alternate course.
5. All adjacent R.C work and masonry walls to be tied with strap irons at every course

MECHANICAL

1. All Plumbing and Drainage Work to comply with specifications
2. S.V.P denotes soil vent pipe and to be provided at the head of the drainage
3. Where drainage is shown under driveways and slabs, to be encased in 150mm thick concrete surround.
4. All underground foul and waste drain pipes shall be of PVC to comply with BS 5255
5. All ICs within building area, driveway and parking to have heavy duty, double-seal airtight covers and walls to be 200mm.
6. Minimum slope in the drain pipes to be 1%
7. No chases for pipes will be allowed in the slabs
8. Sleeves will be allowed with written approval from S.E.
9. No cutting of concrete without express approval of the Architect or S.E
10. All testing of pipes must be coordinated with electrical and any conflicts must be resolved before works begin
11. Permanent vents denoted as P.V to be provided as shown on plan.

ELECTRICAL

All conduits must be laid before plastering

PROJECT:

PROPOSED STUDENT HOUSING FOR ALUPE UNIVERSITY

CLIENT:

Name: STATE DEPARTMENT FOR HOUSING AND URBAN DEVELOPMENT

Signature: _____ Date: _____

DRAWING TITLE:

DOOR SCHEDULE

SCALE:

DRAWN BY: ARCH JMO

CHECKED BY:

Name: _____ Date: _____

DATE:

MINISTRY OF LANDS, PUBLIC WORKS, HOUSING AND URBAN DEVELOPMENT
STATE DEPARTMENT FOR HOUSING & URBAN DEVELOPMENT



FOR THE GOVERNMENT OF THE REPUBLIC OF KENYA

WINDOW SCHEDULE

Window Name	W01	W02	W03	W04	W05
Location	Quad bed, Studio & Single	Washroom	Disabled toilets, Studio ensuites,	Main staircase lobby,	Staircase,
Frame material	25 x 25 x 3mm mild steel "z" sections for frame with tee sections as mullions including permanent vent consisting of a T bar, gauze & 16 gauge sheet metal hood 50mmx50mm high projection full width of window. All members welded, ground & sanded to a smooth finish. Lugged & fixed to jambs ,head & sill with screws & plugged	25 x 25 x 3mm mild steel "z" sections for frame with tee sections as mullions including permanent vent consisting of a T bar, gauze & 16 gauge sheet metal hood 50mmx50mm high projection full width of window. All members welded, ground & sanded to a smooth finish. Lugged & fixed to jambs ,head & sill with screws & plugged	25 x 25 x 3mm mild steel "z" sections for frame with tee sections as mullions including permanent vent consisting of a T bar, gauze & 16 gauge sheet metal hood 50mmx50mm high projection full width of window. All members welded, ground & sanded to a smooth finish. Lugged & fixed to jambs ,head & sill with screws & plugged	25 x 25 x 3mm mild steel "z" sections for frame with tee sections as mullions including permanent vent consisting of a T bar, gauze & 16 gauge sheet metal hood 50mmx50mm high projection full width of window. All members welded, ground & sanded to a smooth finish. Lugged & fixed to jambs ,head & sill with screws & plugged	25 x 25 x 3mm mild steel "z" sections for frame with tee sections as mullions including permanent vent consisting of a T bar, gauze & 16 gauge sheet metal hood 50mmx50mm high projection full width of window. All members welded, ground & sanded to a smooth finish. Lugged & fixed to jambs ,head & sill with screws & plugged
Frame finish	2 coats undercoat (grey oxide rust inhibiting paint) 2 coats finish coat oil paint	2 coats undercoat (grey oxide rust inhibiting paint) 2 coats finish coat oil paint	2 coats undercoat (grey oxide rust inhibiting paint) 2 coats finish coat oil paint	2 coats undercoat (grey oxide rust inhibiting paint) 2 coats finish coat oil paint	2 coats undercoat (grey oxide rust inhibiting paint) 2 coats finish coat oil paint
Glazing	4mm Thick clear sheet panes fixed with putty	4mm Thick clear sheet panes fixed with putty	4mm Thick clear sheet panes fixed with putty	4mm Thick clear sheet panes fixed with putty	4mm Thick clear sheet panes fixed with putty
Ironmongery	Window stays & mild steel hinges	Window stays & mild steel hinges	Window stays & mild steel hinges	Window stays & mild steel hinges	Window stays & mild steel hinges
Quantity	Per floor 48 Total 480	Per floor 14 Total 140	Per floor 16 Total 160	Per floor 2 Total 20	Per floor 2 Total 20
W x H Size	1200x 1500	2400 x 600	600x 600	2400x 1500	1200x 1200
Sill Type	150x 25 mm Thick clay window cill with one rounded edge and throated on the external underside to allow drip	150x 25 mm Thick clay window cill with one rounded edge and throated on the external underside to allow drip	150x 25 mm Thick clay window cill with one rounded edge and throated on the external underside to allow drip	150x 25 mm Thick clay window cill with one rounded edge and throated on the external underside to allow drip	150x 25 mm Thick clay window cill with one rounded edge and throated on the external underside to allow drip
Sill height	900	600	600	900	1200
Head height	2400	1800	2400	2400	2400

GENERAL NOTES

1. This drawing to be read in conjunction with Engineers' drawings.
2. All dimensions are in mm unless otherwise specified.
3. Drawings are not to be scaled. Only figured dimensions should be used.
4. The contractor must check and verify all dimensions before commencement of work and if necessary confirm with the architect.

CONSTRUCTION

Approved anti-termite treatment & 1000 gauge polythene sheeting cover to be provided under all ground floor concrete slab on compacted hardcore to approval.
DPC to be 3ply bituminous felt to be provided under all walls.

STRUCTURAL

1. All Black cotton soil to be removed from below all building and paved surfaces
2. All reinforced concrete work will be in accordance with structural drawings.
3. Foundation depths to be determined on site to S.E approval
4. All walls less than 200mm thick to be reinforced with hoop iron at every alternate course.
5. All adjacent R.C work and masonry walls to be tied with strap irons at every course

MECHANICAL

1. All Plumbing and Drainage Work to comply with specifications
2. S.V.P denotes soil vent pipe and to be provided at the head of the drainage
3. Where drainage is shown under driveways and slabs, to be encased in 150mm thick concrete surround.
4. All underground foul and waste drain pipes shall be of PVC to comply with BS 5255
5. All ICs within building area, driveway and parking to have heavy duty, double-seal airtight covers and walls to be 200mm.
6. Minimum slope in the drain pipes to be 1%
7. No chases for pipes will be allowed in the slabs
8. Sleeves will be allowed with written approval from S.E.
9. No cutting of concrete without express approval of the Architect or S.E
10. All testing of pipes must be coordinated with electrical and any conflicts must be resolved before works begin
11. Permanent vents denoted as P.V to be provided as shown on plan.

ELECTRICAL

All conduits must be laid before plastering

PROJECT:

PROPOSED STUDENT HOUSING FOR ALUPE UNIVERSITY

CLIENT:

Name: STATE DEPARTMENT FOR HOUSING AND URBAN DEVELOPMENT

Signature: _____ Date: _____

DRAWING TITLE:

WINDOW SCHEDULE

SCALE:

DRAWN BY: ARCH JMO

CHECKED BY:

Name: _____

Signature: _____ Date: _____

DATE:

MINISTRY OF LANDS, PUBLIC WORKS,
HOUSING AND URBAN DEVELOPMENT
STATE DEPARTMENT FOR HOUSING & URBAN
DEVELOPMENT



FOR THE GOVERNMENT OF THE
REPUBLIC OF KENYA

DETAILS

STUDENT HOUSING

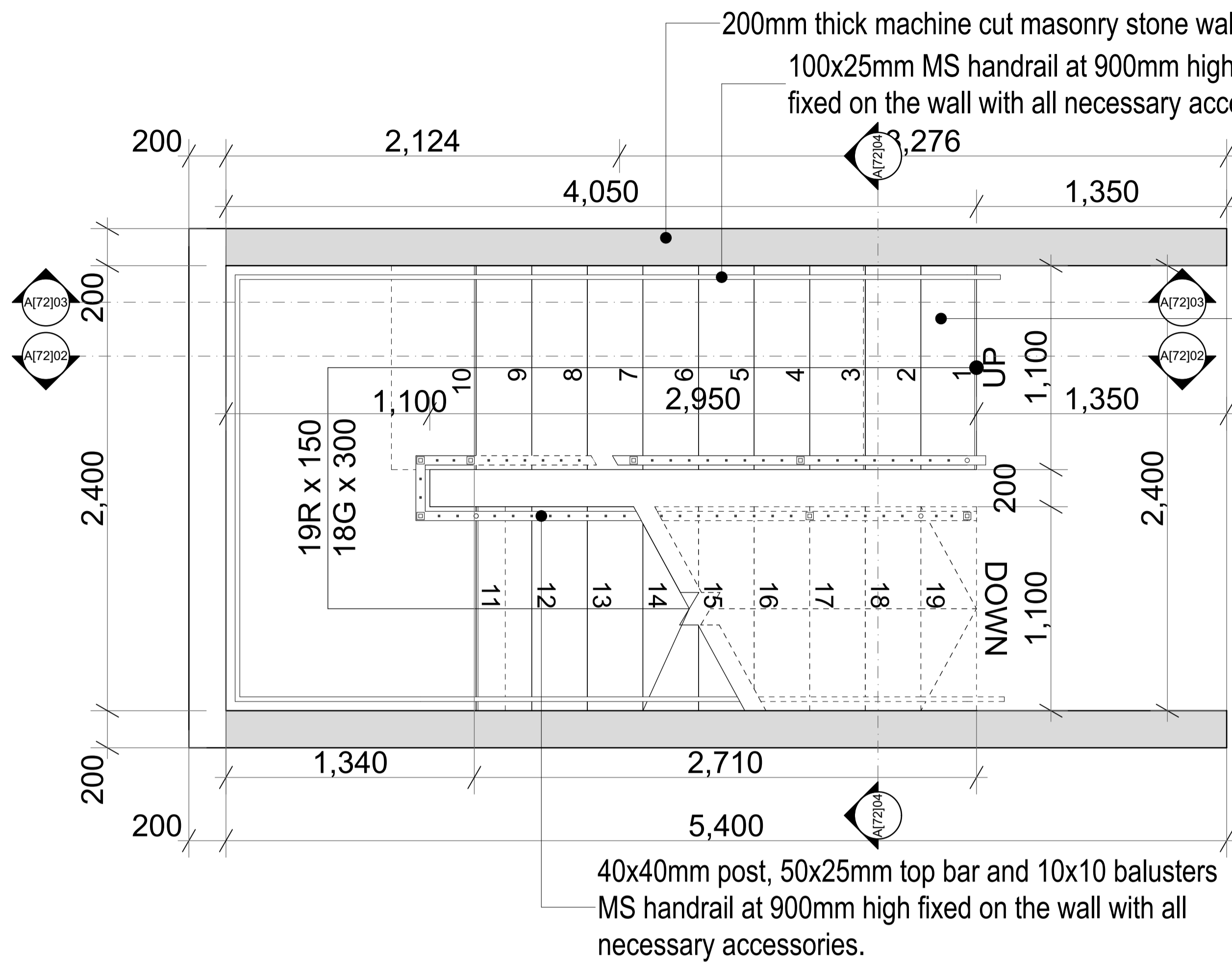

PLAN A[72]01 1:20

RC stairs finished in Terrazo.
19 risers at 150mm.
18 Goings at 300mm.
40x40mm post, 50x25mm top bar and 10x10 balusters
MS handrail at 900mm high fixed on the wall with all necessary accessories.

40x40mm post, 50x25mm top bar and 10x10 balusters
MS handrail at 900mm high fixed on the wall with all necessary accessories.

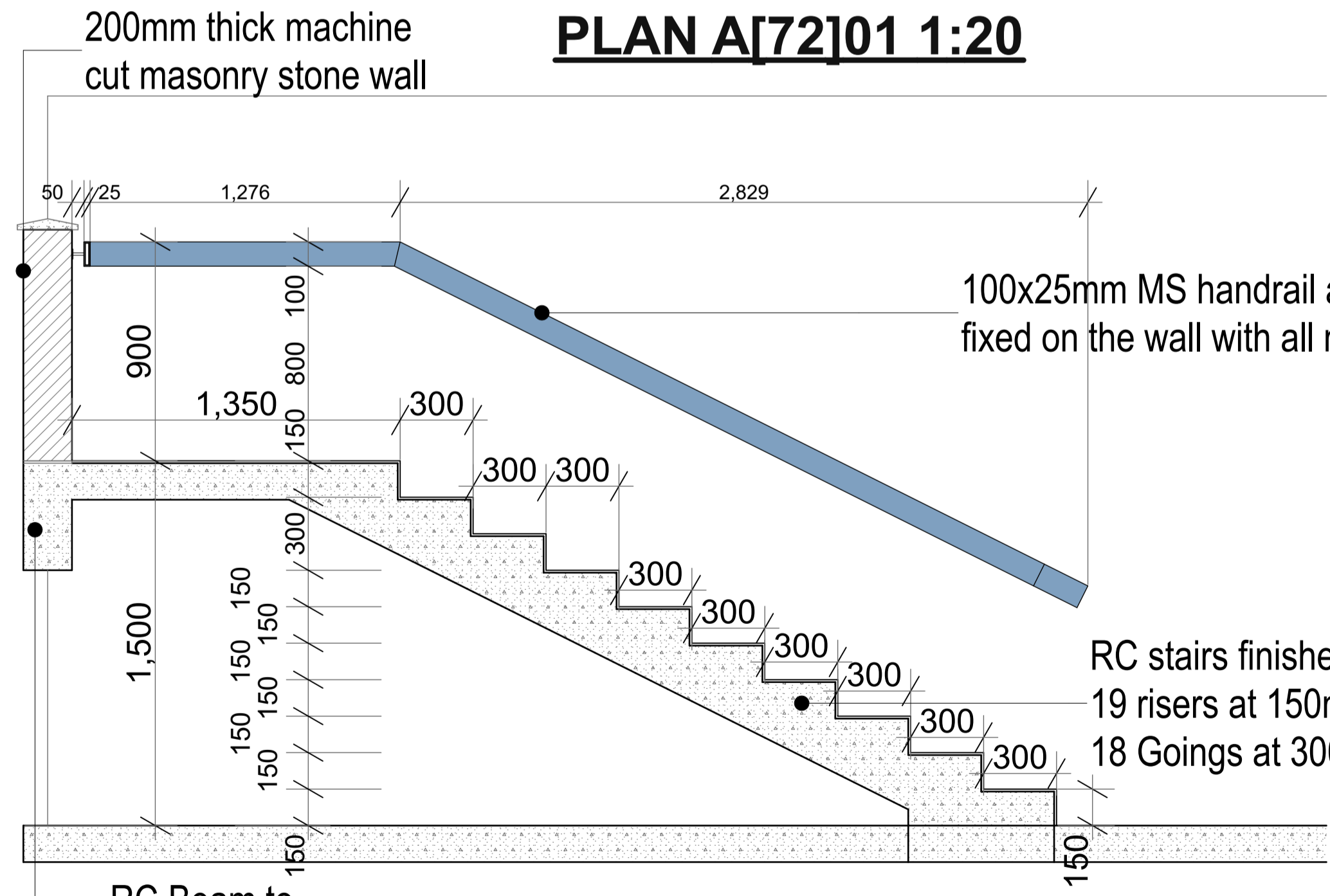

SECTION A[72]03 1:20

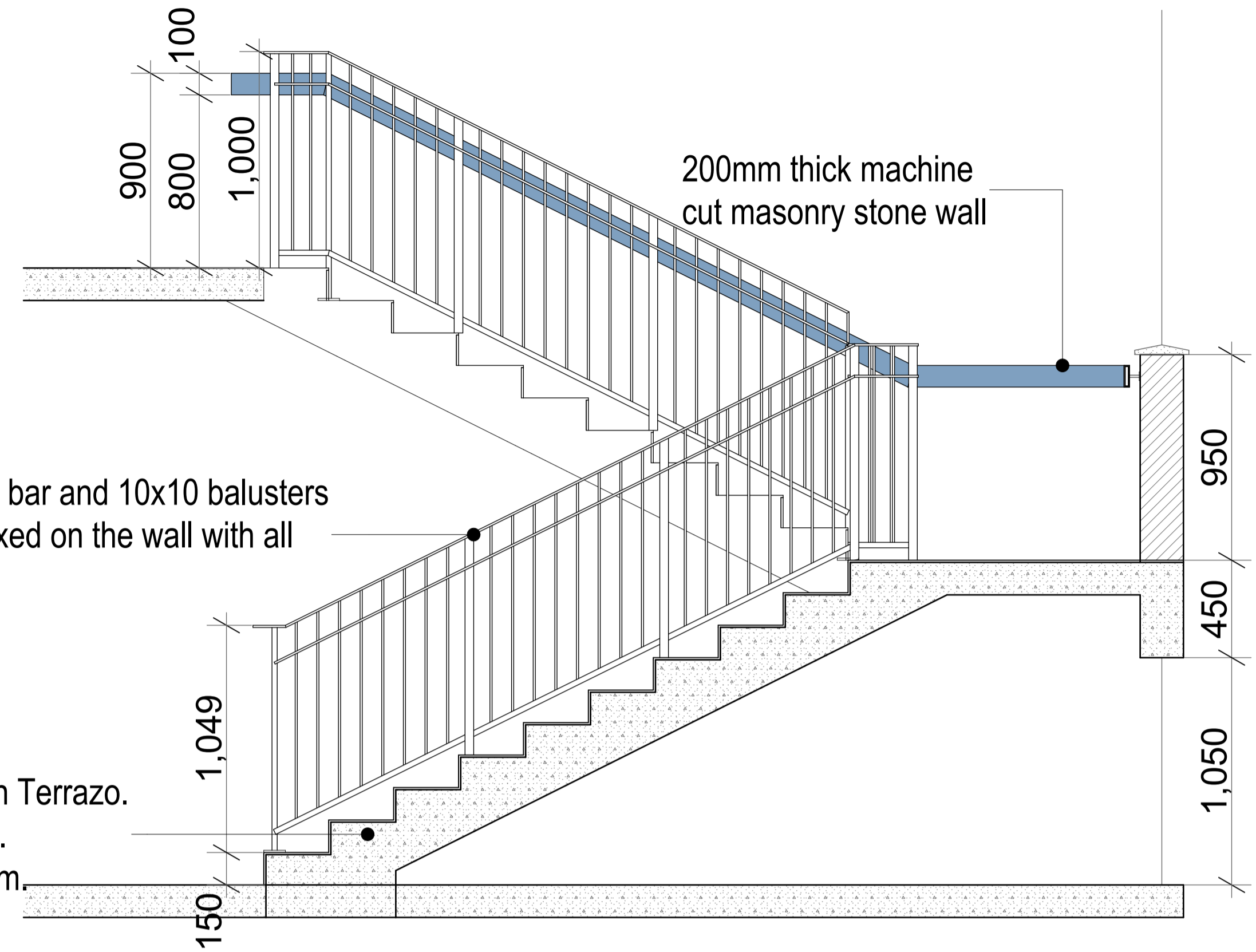

SECTION A[72]02 1:20

RC stairs finished in Terrazo.
19 risers at 150mm.
18 Goings at 300mm.

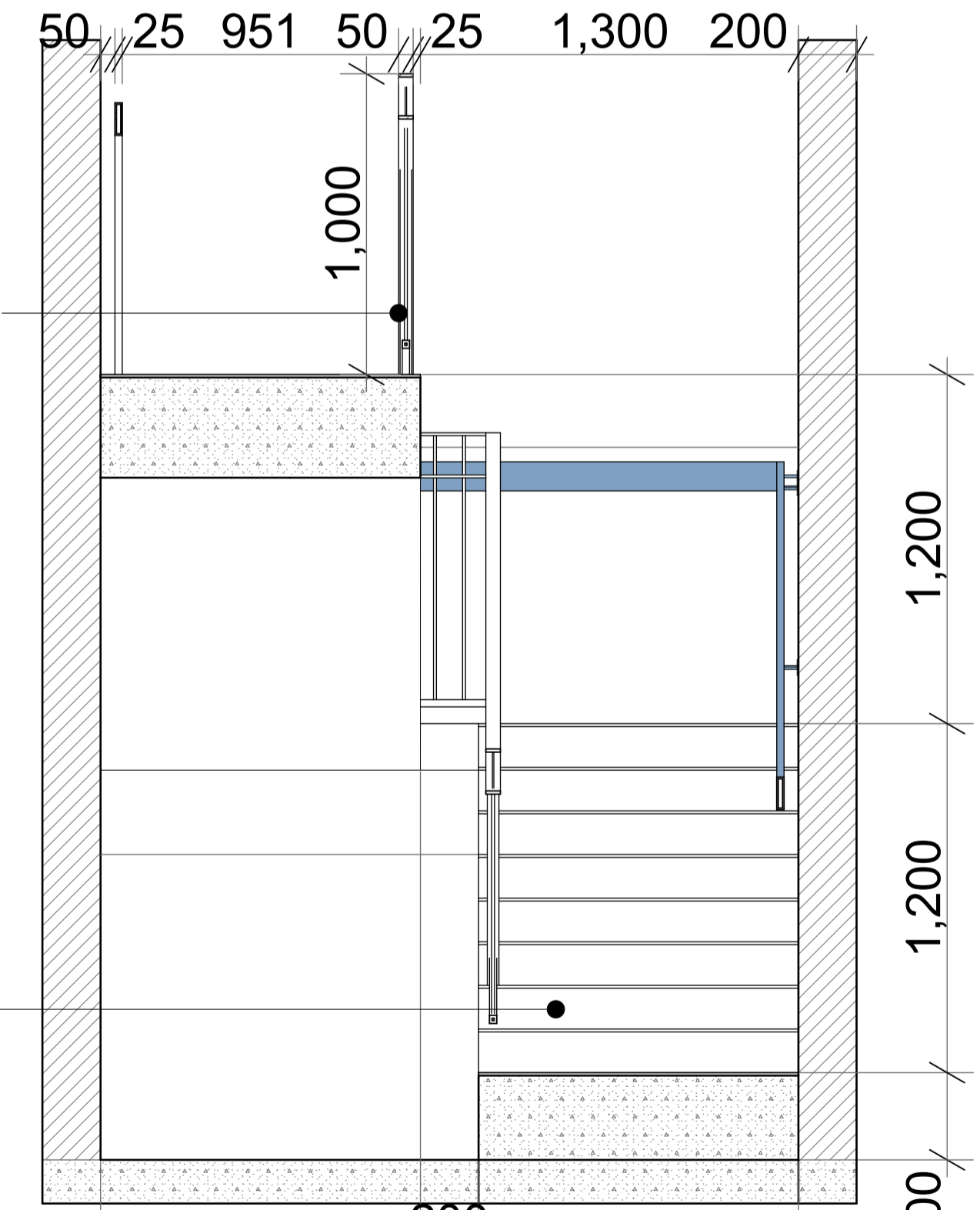

SECTION A[72]04 1:20

RC stairs finished in Terrazo.
19 risers at 150mm.
18 Goings at 300mm.

- GENERAL NOTES**
1. This drawing to be read in conjunction with Engineers' drawings.
 2. All dimensions are in mm unless otherwise specified.
 3. Drawings are not to be scaled. Only figured dimensions should be used.
 4. The contractor must check and verify all dimensions before commencement of work and if necessary confirm with the architect.

CONSTRUCTION
Approved anti-termite treatment & 1000 gauge polythene sheeting cover to be provided under all ground floor concrete slab on compacted hardcore to approval.
DPC to be 3ply bituminous felt to be provided under all walls.

STRUCTURAL

1. All Black cotton soil to be removed from below all building and paved surfaces
2. All reinforced concrete work will be in accordance with structural drawings.
3. Foundation depths to be determined on site to S.E approval
4. All walls less than 200mm thick to be reinforced with hoop iron at every alternate course.
5. All adjacent R.C work and masonry walls to be tied with strap irons at every course

MECHANICAL

1. All Plumbing and Drainage Work to comply with specifications
2. S.V.P denotes soil vent pipe and to be provided at the head of the drainage
3. Where drainage is shown under driveways and slabs, to be encased in 150mm thick concrete surround.
4. All underground foul and waste drain pipes shall be of PVC to comply with BS5255
5. All ICs within building area, driveway and parking to have heavy duty, double-seal airtight covers and walls to be 200mm.
6. Minimum slope in the drain pipes to be 1%
7. No chases for pipes will be allowed in the slabs
8. Sleeves will be allowed with written approval from S.E.
9. No cutting of concrete without express approval of the Architect or S.E
10. All testing of pipes must be coordinated with electrical and any conflicts must be resolved before works begin
11. Permanent vents denoted as P.V to be provided as shown on plan.

ELECTRICAL
All conduits must be laid before plastering

PROJECT:
PROPOSED STUDENT HOUSING FOR ALUPE UNIVERSITY

CLIENT:
Name: STATE DEPARTMENT FOR HOUSING AND URBAN DEVELOPMENT
Signature: _____ Date: _____

DRAWING TITLE:
STAIRS DETAILS

SCALE:
1:20

DRAWN BY:

CHECKED BY:
Name: _____
Signature: _____ Date: _____

DATE:

MINISTRY OF LANDS, PUBLIC WORKS, HOUSING AND URBAN DEVELOPMENT
STATE DEPARTMENT FOR HOUSING & URBAN DEVELOPMENT



FOR THE GOVERNMENT OF THE REPUBLIC OF KENYA



LIFT SECTION A[72]08 1:25

GENERAL NOTES

1. This drawing to be read in conjunction with Engineers' drawings.
2. All dimensions are in mm unless otherwise specified.
3. Drawings are not to be scaled. Only figured dimensions should be used.
4. The contractor must check and verify all dimensions before commencement of work and if necessary confirm with the architect.

CONSTRUCTION

Approved anti-termite treatment & 1000 gauge polythene sheeting cover to be provided under all ground floor concrete slab on compacted hardcore to approval.
DPC to be 3ply bituminous felt to be provided under all walls.

STRUCTURAL

1. All Black cotton soil to be removed from below all building and paved surfaces
2. All reinforced concrete work will be in accordance with structural drawings.
3. Foundation depths to be determined on site to S.E approval
4. All walls less than 200mm thick to be reinforced with hoop iron at every alternate course.
5. All adjacent R.C work and masonry walls to be tied with strap irons at every course

MECHANICAL

1. All Plumbing and Drainage Work to comply with specifications
2. S.V.P denotes soil vent pipe and to be provided at the head of the drainage
3. Where drainage is shown under driveways and slabs, to be encased in 150mm thick concrete surround.
4. All underground foul and waste drain pipes shall be of PVC to comply with BS5255
5. All ICs within building area, driveway and parking to have heavy duty, double-seal airtight covers and walls to be 200mm.
6. Minimum slope in the drain pipes to be 1%
7. No chases for pipes will be allowed in the slabs
8. Sleeves will be allowed with written approval from S.E.
9. No cutting of concrete without express approval of the Architect or S.E
10. All testing of pipes must be coordinated with electrical and any conflicts must be resolved before works begin
11. Permanent vents denoted as P.V to be provided as shown on plan.

ELECTRICAL

All conduits must be laid before plastering

PROJECT:

PROPOSED STUDENT HOUSING FOR ALUPE UNIVERSITY

CLIENT:

Name: STATE DEPARTMENT FOR HOUSING AND URBAN DEVELOPMENT

Signature: _____ Date: _____

DRAWING TITLE:

LIFT SHAFT DETAIL

SCALE:

1:1000

DRAWN BY:

CHECKED BY:

Name: _____

Signature: _____ Date: _____

DATE:

MINISTRY OF LANDS, PUBLIC WORKS, HOUSING AND URBAN DEVELOPMENT

STATE DEPARTMENT FOR HOUSING & URBAN DEVELOPMENT



FOR THE GOVERNMENT OF THE REPUBLIC OF KENYA

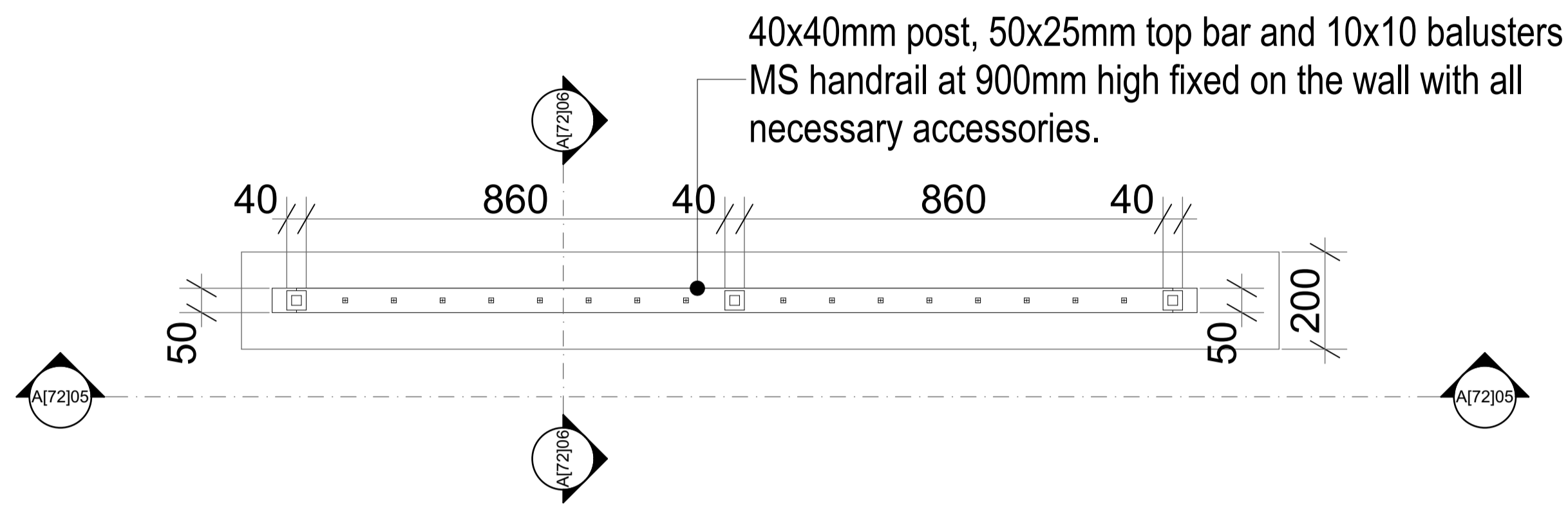

PLAN A[72]07 1:10

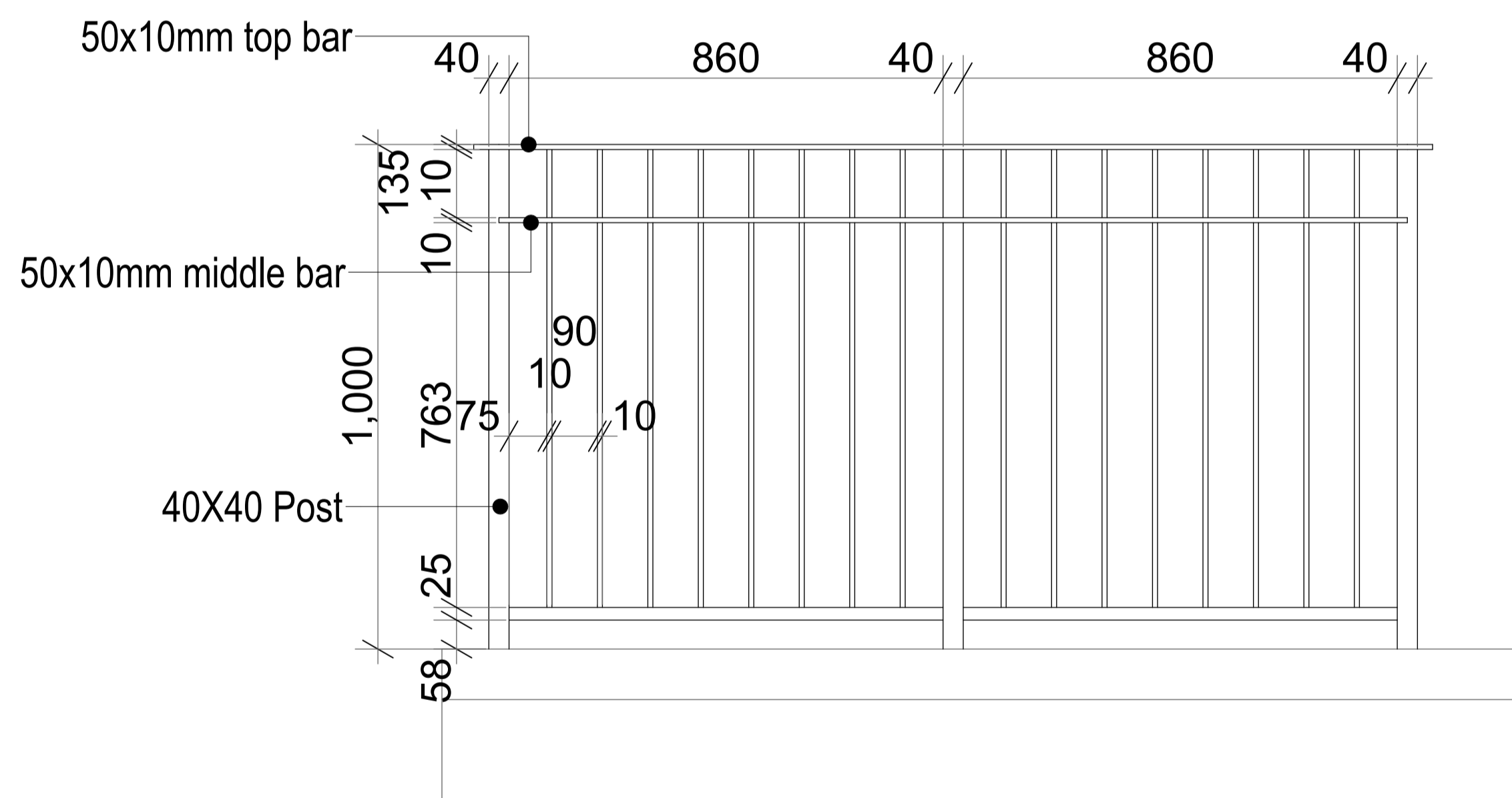

ELEVATION A[72]05 1:10

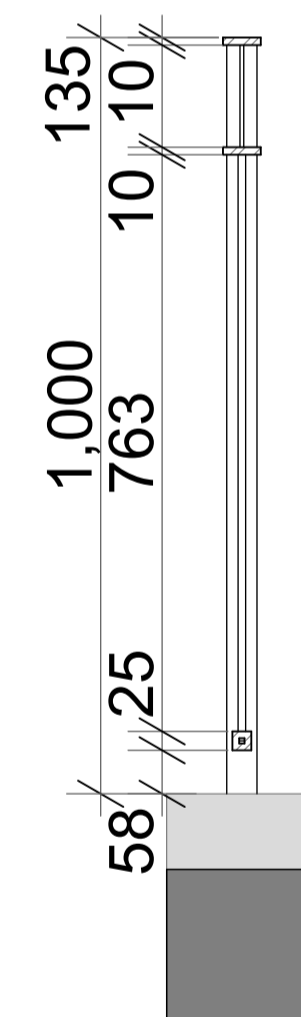

SECTION A[72]06 1:10

GENERAL NOTES

1. This drawing to be read in conjunction with Engineers' drawings.
2. All dimensions are in mm unless otherwise specified.
3. Drawings are not to be scaled. Only figured dimensions should be used.
4. The contractor must check and verify all dimensions before commencement of work and if necessary confirm with the architect.

CONSTRUCTION

Approved anti-termite treatment & 1000 gauge polythene sheeting cover to be provided under all ground floor concrete slab on compacted hardcore to approval.
DPC to be 3ply bituminous felt to be provided under all walls.

STRUCTURAL

1. All Black cotton soil to be removed from below all building and paved surfaces
2. All reinforced concrete work will be in accordance with structural drawings.
3. Foundation depths to be determined on site to S.E approval
4. All walls less than 200mm thick to be reinforced with hoop iron at every alternate course.
5. All adjacent R.C work and masonry walls to be tied with strap irons at every course

MECHANICAL

1. All Plumbing and Drainage Work to comply with specifications
2. S.V.P denotes soil vent pipe and to be provided at the head of the drainage
3. Where drainage is shown under driveways and slabs, to be encased in 150mm thick concrete surround.
4. All underground foul and waste drain pipes shall be of PVC to comply with BS5255
5. All ICs within building area, driveway and parking to have heavy duty, double-seal airtight covers and walls to be 200mm.
6. Minimum slope in the drain pipes to be 1%
7. No chases for pipes will be allowed in the slabs
8. Sleeves will be allowed with written approval from S.E.
9. No cutting of concrete without express approval of the Architect or S.E
10. All testing of pipes must be coordinated with electrical and any conflicts must be resolved before works begin
11. Permanent vents denoted as P.V to be provided as shown on plan.

ELECTRICAL

All conduits must be laid before plastering

PROJECT:

PROPOSED STUDENT HOUSING FOR ALUPE UNIVERSITY

CLIENT:

Name: STATE DEPARTMENT FOR HOUSING AND URBAN DEVELOPMENT

Signature: _____ Date: _____

DRAWING TITLE:

RAILING DETAILS

SCALE:

1:10

DRAWN BY:

CHECKED BY:

Name: _____

Signature: _____ Date: _____

DATE:

MINISTRY OF LANDS, PUBLIC WORKS, HOUSING AND URBAN DEVELOPMENT

STATE DEPARTMENT FOR HOUSING & URBAN DEVELOPMENT



FOR THE GOVERNMENT OF THE REPUBLIC OF KENYA

GENERAL NOTES

1. This drawing to be read in conjunction with Engineers' drawings.
2. All dimensions are in mm unless otherwise specified.
3. Drawings are not to be scaled. Only figured dimensions should be used.
4. The contractor must check and verify all dimensions before commencement of work and if necessary confirm with the architect.

CONSTRUCTION

Approved anti-termite treatment & 1000 gauge polythene sheeting cover to be provided under all ground floor concrete slab on compacted hardcore to approval.
DPC to be 3ply bituminous felt to be provided under all walls.

STRUCTURAL

1. All Black cotton soil to be removed from below all building and paved surfaces
2. All reinforced concrete work will be in accordance with structural drawings.
3. Foundation depths to be determined on site to S.E approval
4. All walls less than 200mm thick to be reinforced with hoop iron at every alternate course.
5. All adjacent R.C work and masonry walls to be tied with strap irons at every course

MECHANICAL

1. All Plumbing and Drainage Work to comply with specifications
2. S.V.P denotes soil vent pipe and to be provided at the head of the drainage
3. Where drainage is shown under driveways and slabs, to be encased in 150mm thick concrete surround.
4. All underground foul and waste drain pipes shall be of PVC to comply with BS5255
5. All ICs within building area, driveway and parking to have heavy duty, double-seal airtight covers and walls to be 200mm.
6. Minimum slope in the drain pipes to be 1%
7. No chases for pipes will be allowed in the slabs
8. Sleeves will be allowed with written approval from S.E.
9. No cutting of concrete without express approval of the Architect or S.E
10. All testing of pipes must be coordinated with electrical and any conflicts must be resolved before works begin
11. Permanent vents denoted as P.V to be provided as shown on plan.

ELECTRICAL

All conduits must be laid before plastering

PROJECT:

PROPOSED STUDENT HOUSING FOR ALUPE UNIVERSITY

CLIENT:

Name: STATE DEPARTMENT FOR HOUSING AND URBAN DEVELOPMENT

Signature: _____ Date: _____

DRAWING TITLE:

SCALE:

1:25

DRAWN BY:

CHECKED BY:

Name: _____

Signature: _____ Date: _____

DATE:

MINISTRY OF LANDS, PUBLIC WORKS, HOUSING AND URBAN DEVELOPMENT

STATE DEPARTMENT FOR HOUSING & URBAN DEVELOPMENT



FOR THE GOVERNMENT OF THE REPUBLIC OF KENYA

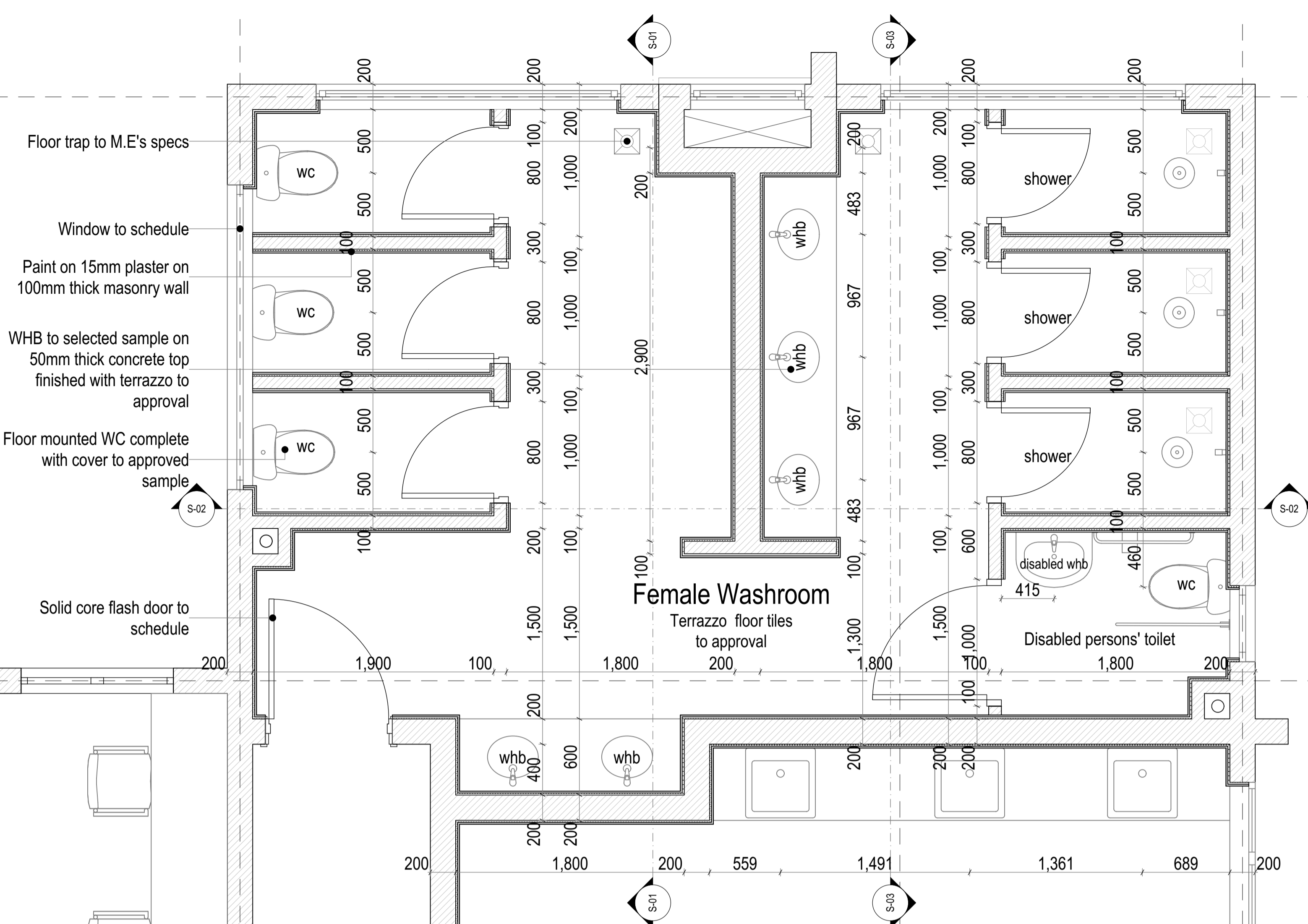

SETTING OUT PLAN
SCALE 1:25

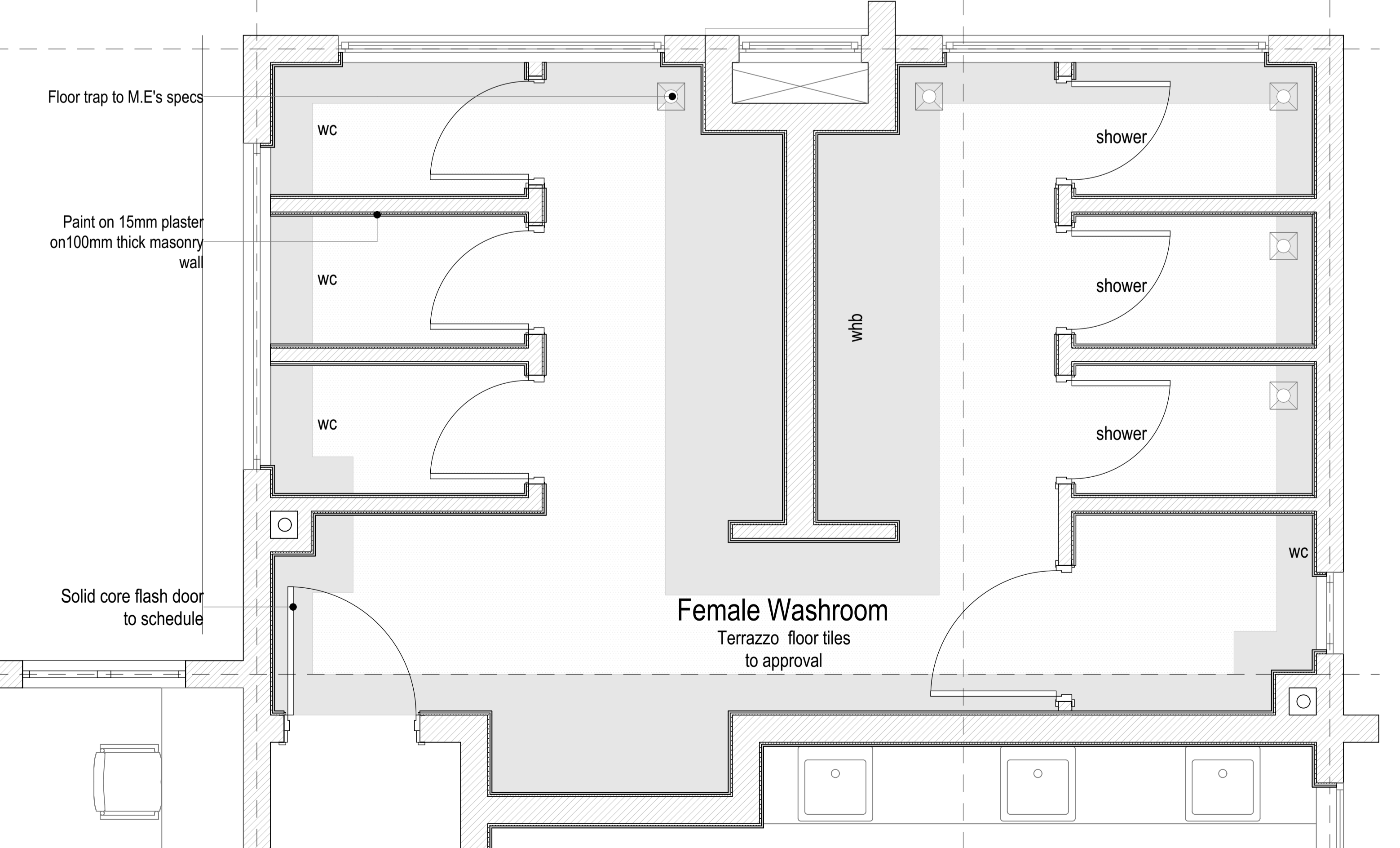

FINISHING LAYOUT PLAN
SCALE 1:25

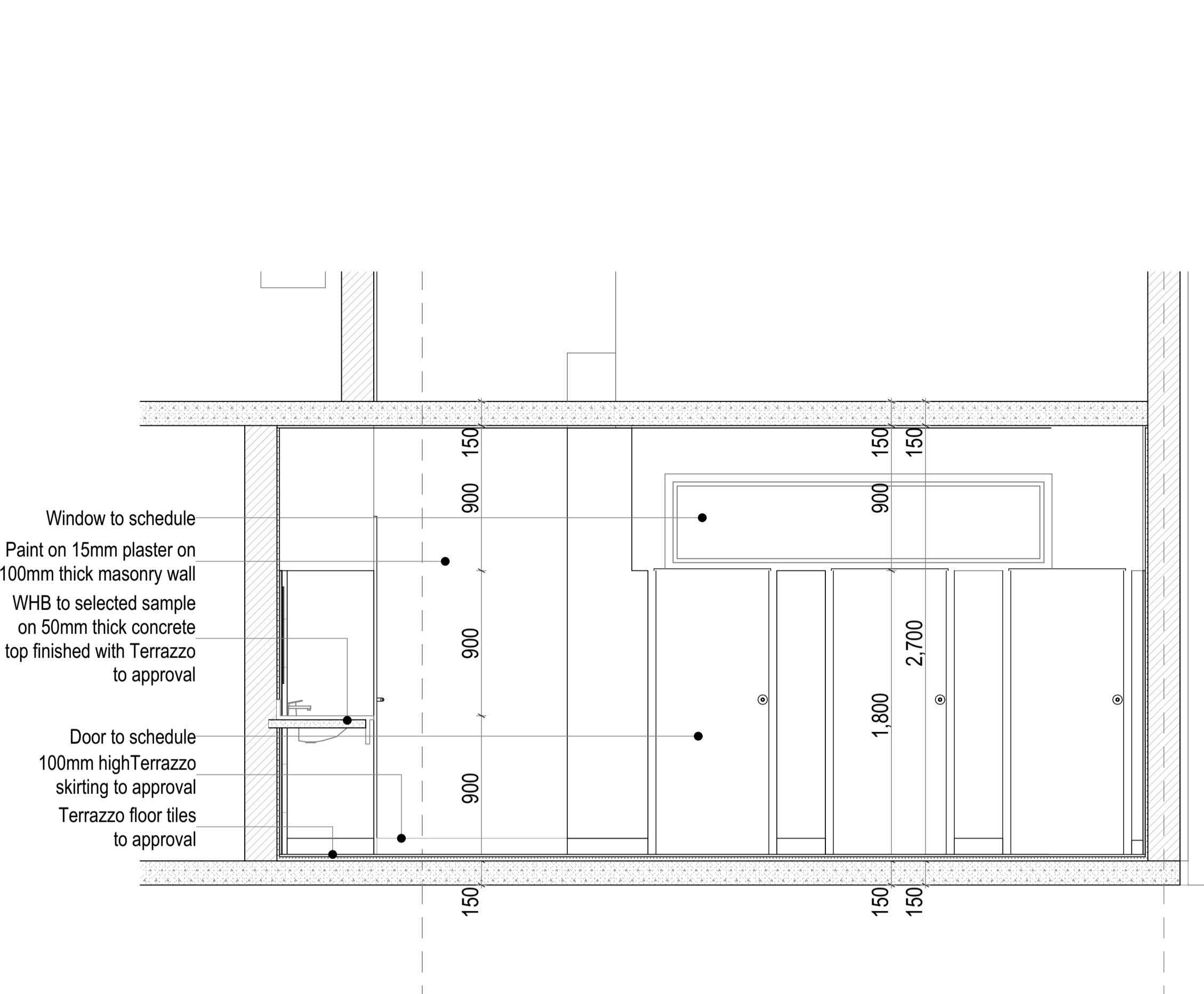

SECTION 01-01
SCALE 1:25

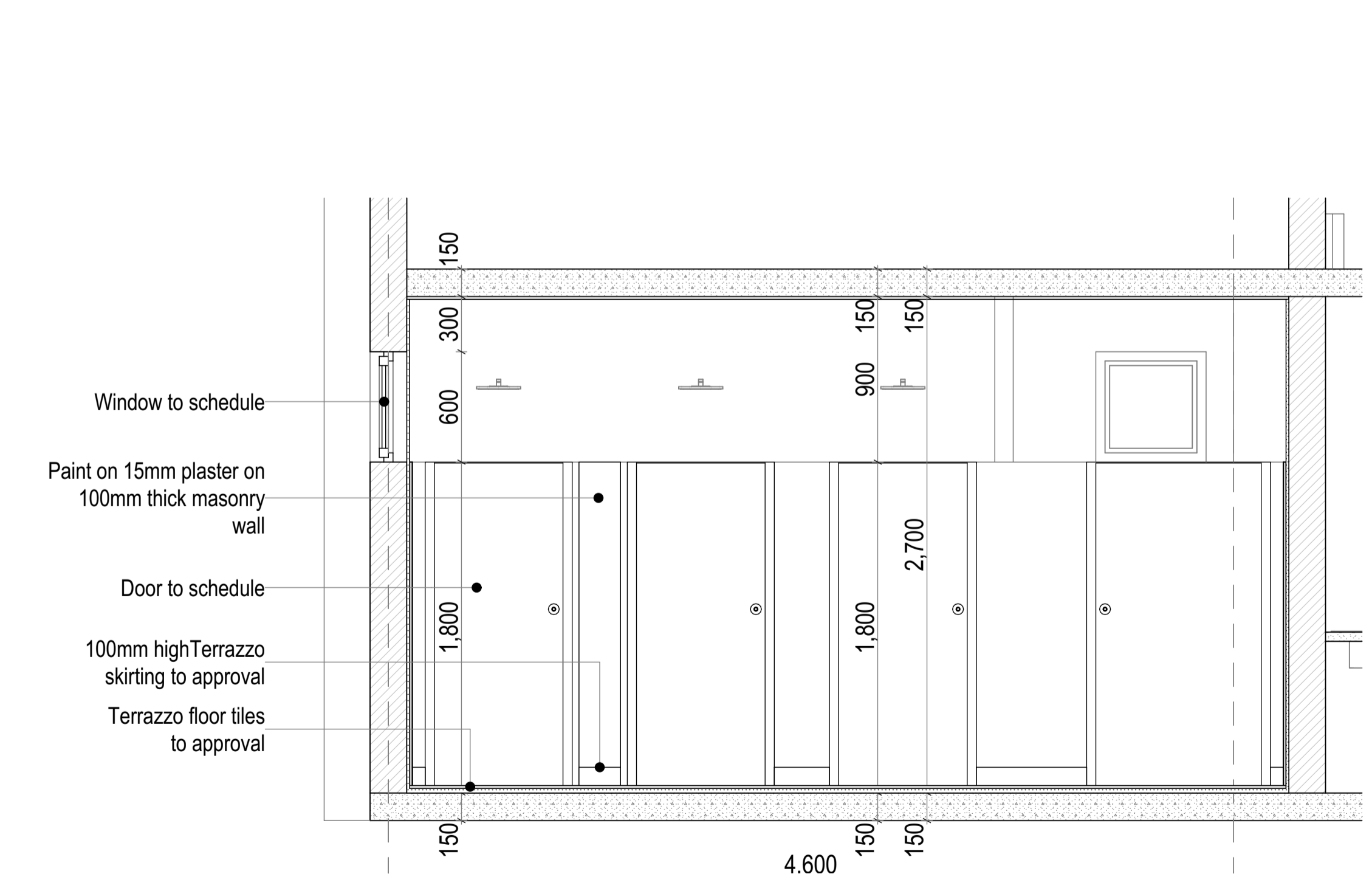

SECTION 03-03
SCALE 1:25

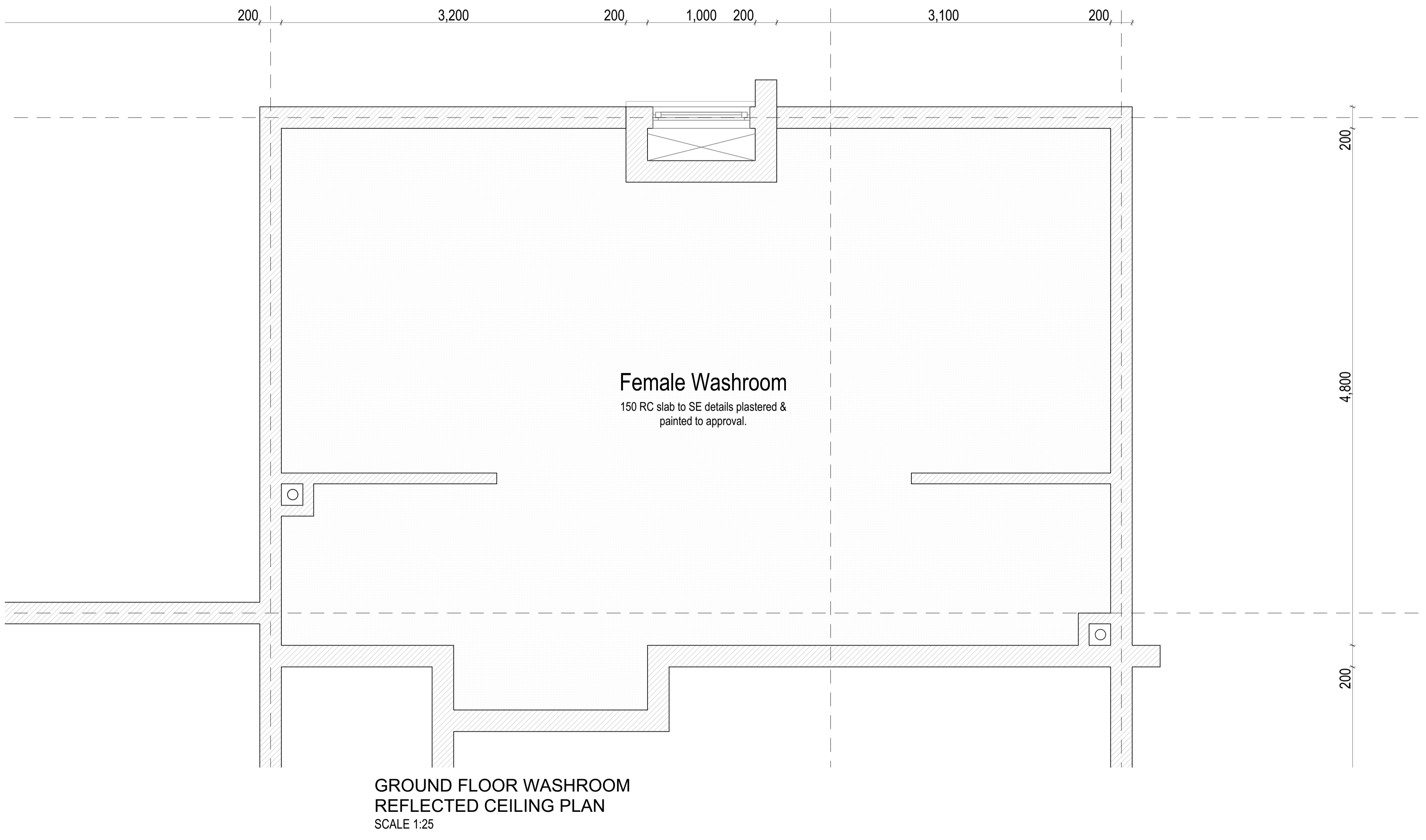
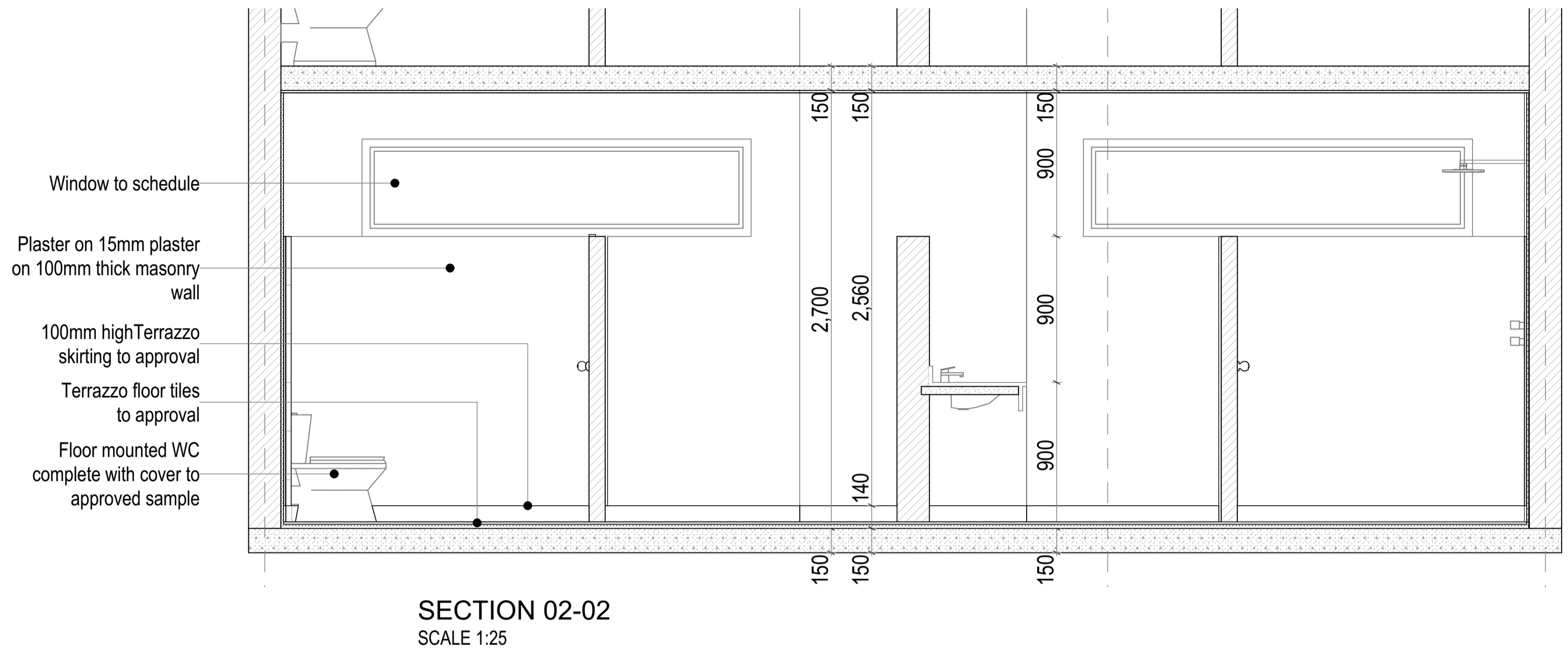

GENERAL NOTES

1. This drawing to be read in conjunction with Engineers' drawings.
2. All dimensions are in mm unless otherwise specified.
3. Drawings are not to be scaled. Only figured dimensions should be used.
4. The contractor must check and verify all dimensions before commencement of work and if necessary confirm with the architect.

CONSTRUCTION

Approved anti-termite treatment & 1000 gauge polythene sheeting cover to be provided under all ground floor concrete slab on compacted hardcore to approval.
DPC to be 3ply bituminous felt to be provided under all walls.

STRUCTURAL

1. All Black cotton soil to be removed from below all building and paved surfaces
2. All reinforced concrete work will be in accordance with structural drawings.
3. Foundation depths to be determined on site to S.E approval
4. All walls less than 200mm thick to be reinforced with hoop iron at every alternate course.
5. All adjacent R.C work and masonry walls to be tied with strap irons at every course

MECHANICAL

1. All Plumbing and Drainage Work to comply with specifications
2. S.V.P denotes soil vent pipe and to be provided at the head of the drainage
3. Where drainage is shown under driveways and slabs, to be encased in 150mm thick concrete surround.
4. All underground foul and waste drain pipes shall be of PVC to comply with BS5255
5. All ICs within building area, driveway and parking to have heavy duty, double-seal airtight covers and walls to be 200mm.
6. Minimum slope in the drain pipes to be 1%
7. No chases for pipes will be allowed in the slabs
8. Sleeves will be allowed with written approval from S.E.
9. No cutting of concrete without express approval of the Architect or S.E
10. All testing of pipes must be coordinated with electrical and any conflicts must be resolved before works begin
11. Permanent vents denoted as P.V to be provided as shown on plan.

ELECTRICAL

All conduits must be laid before plastering

PROJECT:

PROPOSED STUDENT HOUSING FOR ALUPE UNIVERSITY

CLIENT:

Name: STATE DEPARTMENT FOR HOUSING AND URBAN DEVELOPMENT

Signature: _____ Date: _____

DRAWING TITLE:

SCALE:

1:25

DRAWN BY:

CHECKED BY:

Name: _____

Signature: _____ Date: _____

DATE:

MINISTRY OF LANDS, PUBLIC WORKS, HOUSING AND URBAN DEVELOPMENT

STATE DEPARTMENT FOR HOUSING & URBAN DEVELOPMENT



FOR THE GOVERNMENT OF THE REPUBLIC OF KENYA

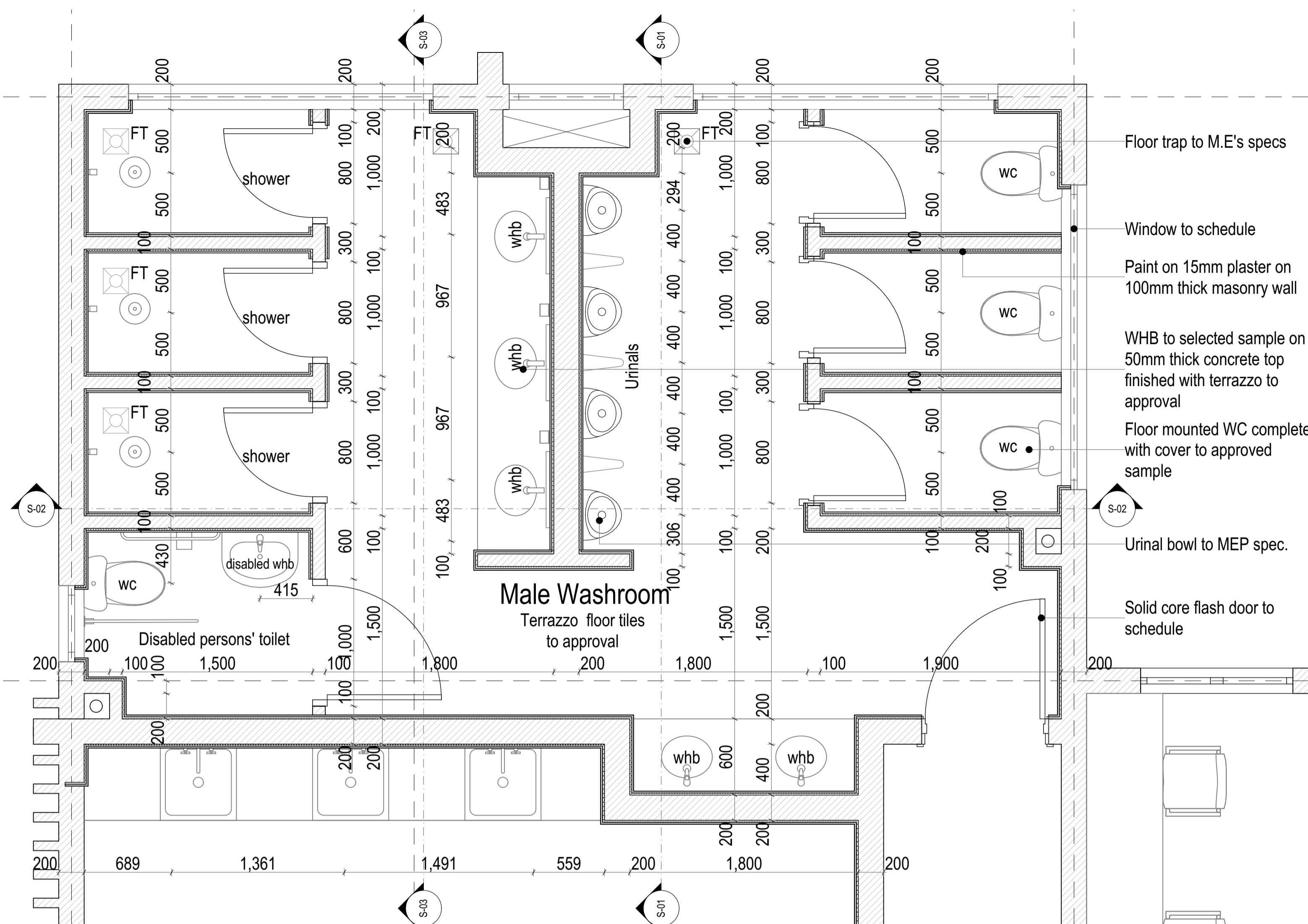

SETTING OUT PLAN
SCALE 1:25

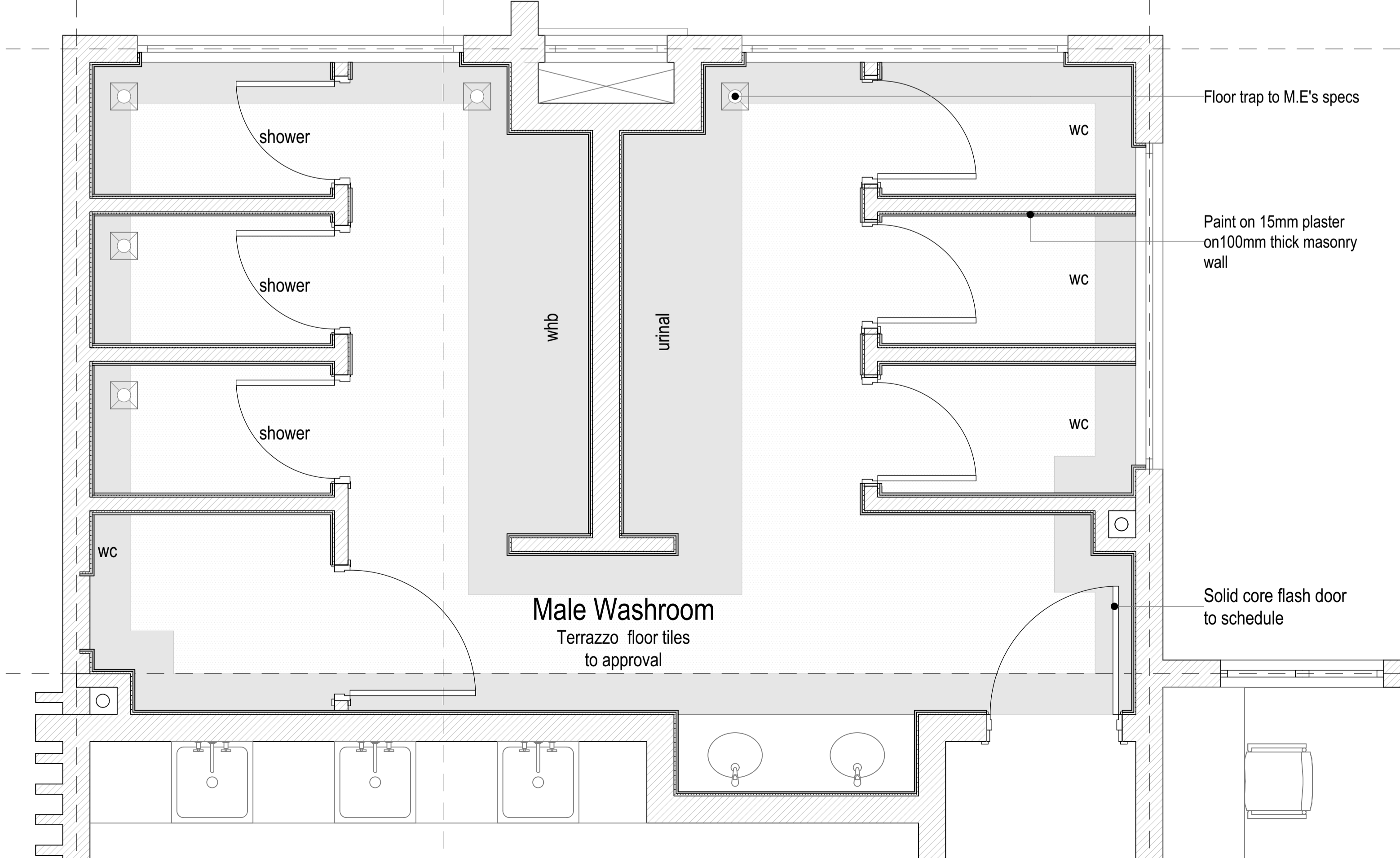

FINISHING LAYOUT PLAN
SCALE 1:25

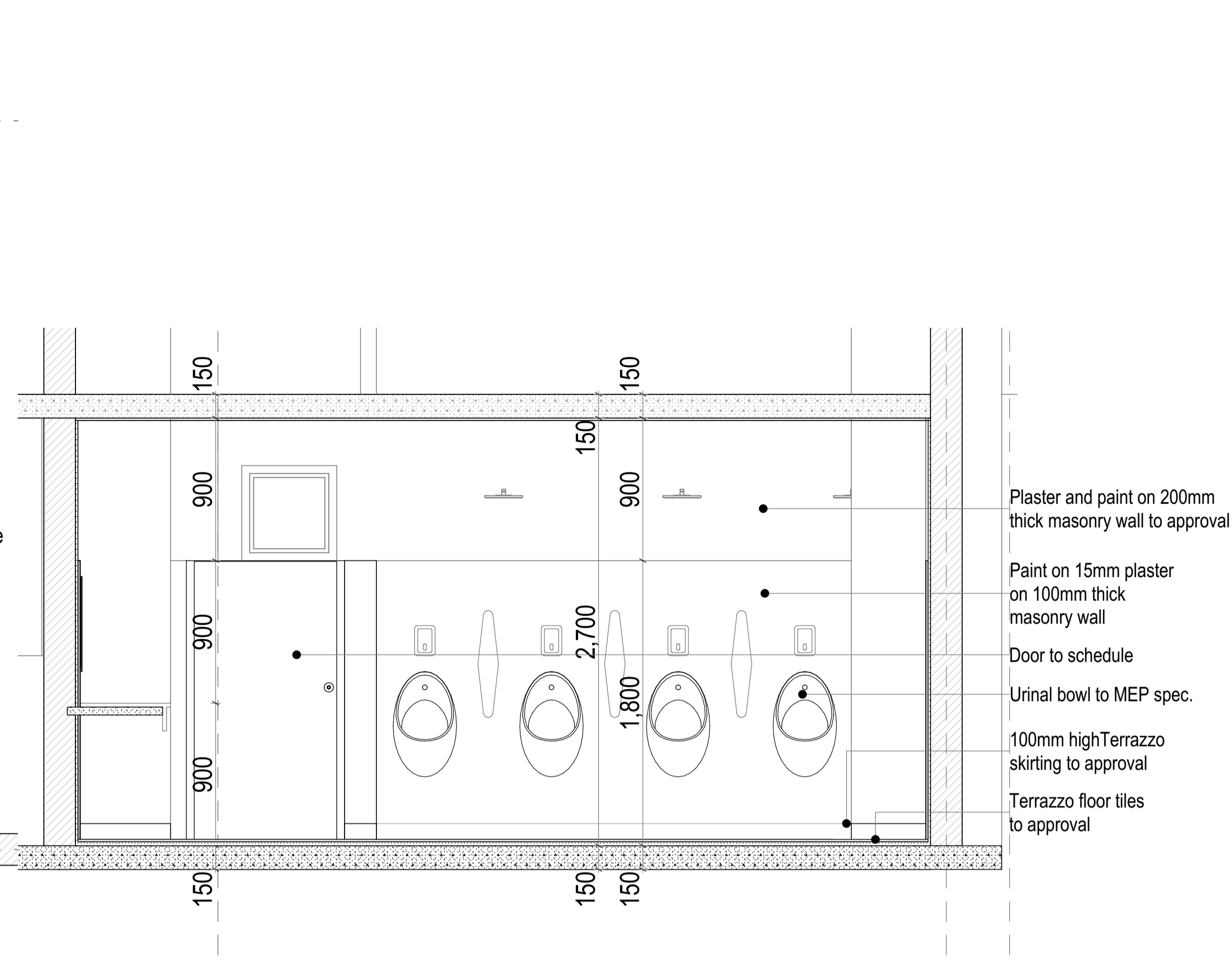

SECTION 01-01
SCALE 1:25

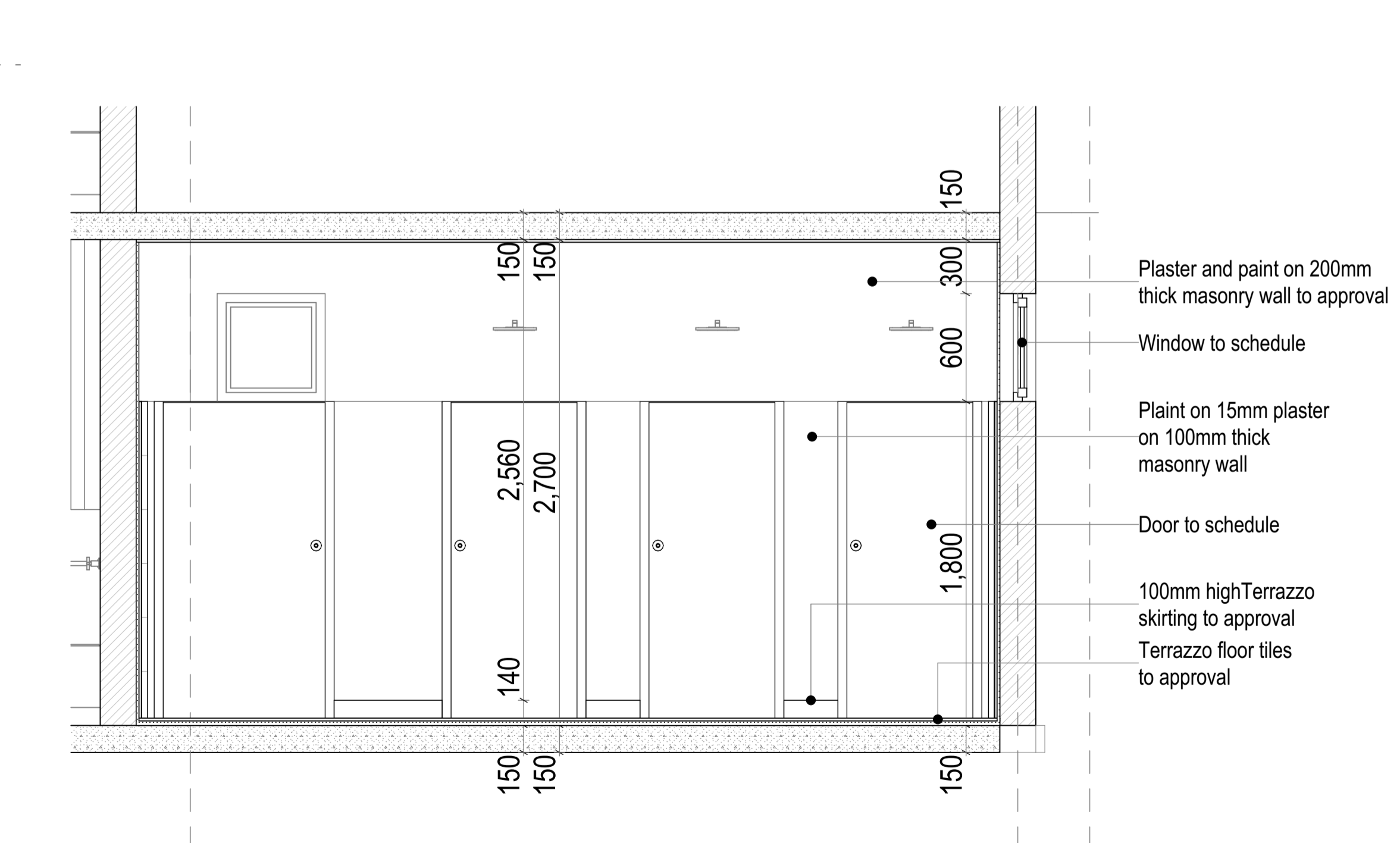

SECTION 03-03
SCALE 1:25

- GENERAL NOTES**
1. This drawing to be read in conjunction with Engineers' drawings.
 2. All dimensions are in mm unless otherwise specified.
 3. Drawings are not to be scaled. Only figured dimensions should be used.
 4. The contractor must check and verify all dimensions before commencement of work and if necessary confirm with the architect.

CONSTRUCTION
Approved anti-termite treatment & 1000 gauge polythene sheeting cover to be provided under all ground floor concrete slab on compacted hardcore to approval.
DPC to be 3ply bituminous felt to be provided under all walls.

- STRUCTURAL**
1. All Black cotton soil to be removed from below all building and paved surfaces
 2. All reinforced concrete work will be in accordance with structural drawings.
 3. Foundation depths to be determined on site to S.E approval
 4. All walls less than 200mm thick to be reinforced with hoop iron at every alternate course.
 5. All adjacent R.C work and masonry walls to be tied with strap irons at every course

- MECHANICAL**
1. All Plumbing and Drainage Work to comply with specifications
 2. S.V.P denotes soil vent pipe and to be provided at the head of the drainage
 3. Where drainage is shown under driveways and slabs, to be encased in 150mm thick concrete surround.
 4. All underground foul and waste drain pipes shall be of PVC to comply with BS5255
 5. All ICs within building area, driveway and parking to have heavy duty, double-seal airtight covers and walls to be 200mm.
 6. Minimum slope in the drain pipes to be 1%
 7. No chases for pipes will be allowed in the slabs
 8. Sleeves will be allowed with written approval from S.E.
 9. No cutting of concrete without express approval of the Architect or S.E
 10. All testing of pipes must be coordinated with electrical and any conflicts must be resolved before works begin
 11. Permanent vents denoted as P.V to be provided as shown on plan.

ELECTRICAL
All conduits must be laid before plastering

PROJECT:
PROPOSED STUDENT HOUSING FOR ALUPE UNIVERSITY

CLIENT:
Name: STATE DEPARTMENT FOR HOUSING AND URBAN DEVELOPMENT
Signature: _____ Date: _____

DRAWING TITLE:

SCALE:
1:25

DRAWN BY:

CHECKED BY:
Name: _____
Signature: _____ Date: _____

DATE:

MINISTRY OF LANDS, PUBLIC WORKS, HOUSING AND URBAN DEVELOPMENT
STATE DEPARTMENT FOR HOUSING & URBAN DEVELOPMENT



FOR THE GOVERNMENT OF THE
REPUBLIC OF KENYA

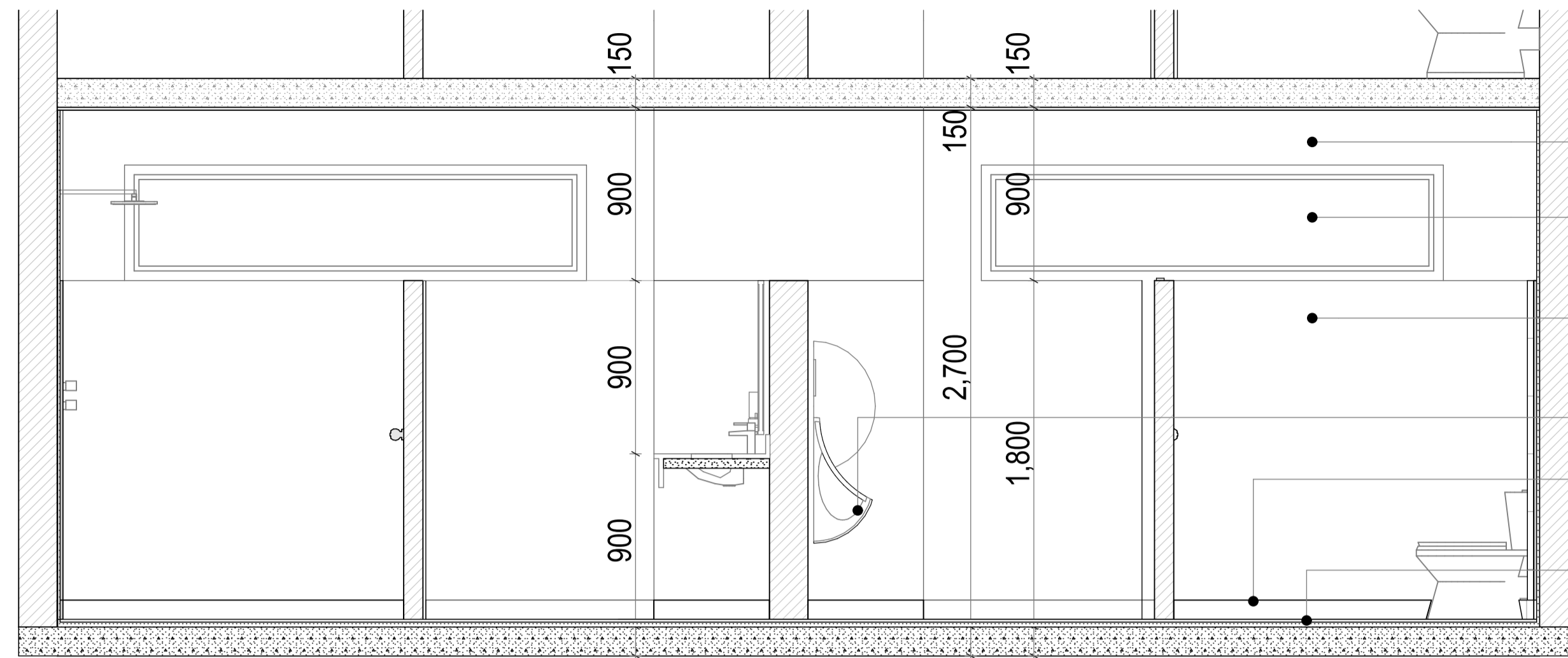

- Plaster and paint on 200mm thick masonry wall to approval
- Window to schedule
- Paint on 15mm plaster on 100mm thick masonry wall
- Urinal bowl to MEP spec.
- 100mm high terrazzo skirting to approval
- Terrazzo floor tiles to approval

SECTION 02-02
SCALE 1:25

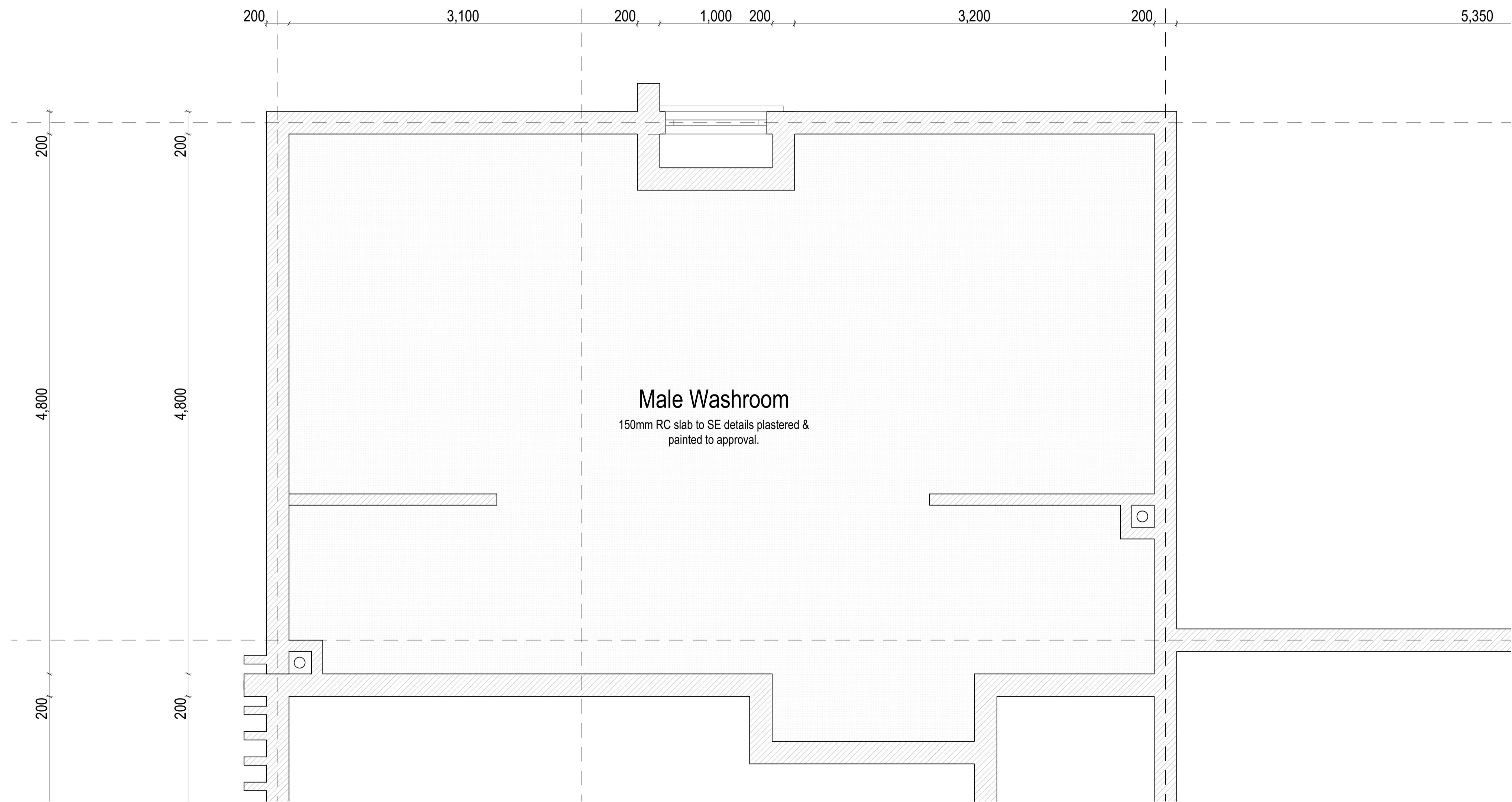

GROUND FLOOR WASHROOM
REFLECTED CEILING PLAN
SCALE 1:25

GENERAL NOTES

1. This drawing to be read in conjunction with Engineers' drawings.
2. All dimensions are in mm unless otherwise specified.
3. Drawings are not to be scaled. Only figured dimensions should be used.
4. The contractor must check and verify all dimensions before commencement of work and if necessary confirm with the architect.

CONSTRUCTION

Approved anti-termite treatment & 1000 gauge polythene sheeting cover to be provided under all ground floor concrete slab on compacted hardcore to approval.
DPC to be 3ply bituminous felt to be provided under all walls.

STRUCTURAL

1. All Black cotton soil to be removed from below all building and paved surfaces
2. All reinforced concrete work will be in accordance with structural drawings.
3. Foundation depths to be determined on site to S.E approval
4. All walls less than 200mm thick to be reinforced with hoop iron at every alternate course.
5. All adjacent R.C work and masonry walls to be tied with strap irons at every course

MECHANICAL

1. All Plumbing and Drainage Work to comply with specifications
2. S.V.P denotes soil vent pipe and to be provided at the head of the drainage
3. Where drainage is shown under driveways and slabs, to be encased in 150mm thick concrete surround.
4. All underground foul and waste drain pipes shall be of PVC to comply with BS5255
5. All ICs within building area, driveway and parking to have heavy duty, double-seal airtight covers and walls to be 200mm.
6. Minimum slope in the drain pipes to be 1%
7. No chases for pipes will be allowed in the slabs
8. Sleeves will be allowed with written approval from S.E.
9. No cutting of concrete without express approval of the Architect or S.E
10. All testing of pipes must be coordinated with electrical and any conflicts must be resolved before works begin
11. Permanent vents denoted as P.V to be provided as shown on plan.

ELECTRICAL

All conduits must be laid before plastering

PROJECT:

PROPOSED STUDENT HOUSING FOR ALUPE UNIVERSITY

CLIENT:

Name: STATE DEPARTMENT FOR HOUSING AND URBAN DEVELOPMENT

Signature: _____ Date: _____

DRAWING TITLE:

SCALE:

1:25

DRAWN BY:

CHECKED BY:

Name: _____

Signature: _____ Date: _____

DATE:

MINISTRY OF LANDS, PUBLIC WORKS, HOUSING AND URBAN DEVELOPMENT

STATE DEPARTMENT FOR HOUSING & URBAN DEVELOPMENT



FOR THE GOVERNMENT OF THE REPUBLIC OF KENYA

GENERAL NOTES

1. This drawing to be read in conjunction with Engineers' drawings.
2. All dimensions are in mm unless otherwise specified.
3. Drawings are not to be scaled. Only figured dimensions should be used.
4. The contractor must check and verify all dimensions before commencement of work and if necessary confirm with the architect.

CONSTRUCTION

Approved anti-termite treatment & 1000 gauge polythene sheeting cover to be provided under all ground floor concrete slab on compacted hardcore to approval.
DPC to be 3ply bituminous felt to be provided under all walls.

STRUCTURAL

1. All Black cotton soil to be removed from below all building and paved surfaces
2. All reinforced concrete work will be in accordance with structural drawings.
3. Foundation depths to be determined on site to S.E approval
4. All walls less than 200mm thick to be reinforced with hoop iron at every alternate course.
5. All adjacent R.C work and masonry walls to be tied with strap irons at every course

MECHANICAL

1. All Plumbing and Drainage Work to comply with specifications
2. S.V.P denotes soil vent pipe and to be provided at the head of the drainage
3. Where drainage is shown under driveways and slabs, to be encased in 150mm thick concrete surround.
4. All underground foul and waste drain pipes shall be of PVC to comply with BS5255
5. All ICs within building area driveway and parking to have heavy duty, double-seal airtight covers and walls to be 200mm.
6. Minimum slope in the drain pipes to be 1%
7. No chases for pipes will be allowed in the slabs
8. Sleeves will be allowed with written approval from S.E.
9. No cutting of concrete without express approval of the Architect or S.E
10. All testing of pipes must be coordinated with electrical and any conflicts must be resolved before works begin
11. Permanent vents denoted as P.V to be provided as shown on plan.

ELECTRICAL

All conduits must be laid before plastering

PROJECT:

PROPOSED STUDENT HOUSING FOR ALUPE UNIVERSITY

CLIENT:

Name: STATE DEPARTMENT FOR HOUSING AND URBAN DEVELOPMENT

Signature: _____ Date: _____

DRAWING TITLE:

Boundary Wall

SCALE:

1:100

DRAWN BY:

CHECKED BY:

Name: _____

Signature: _____ Date: _____

DATE:

MINISTRY OF LANDS, PUBLIC WORKS, HOUSING AND URBAN DEVELOPMENT

STATE DEPARTMENT FOR HOUSING & URBAN DEVELOPMENT



FOR THE GOVERNMENT OF THE REPUBLIC OF KENYA

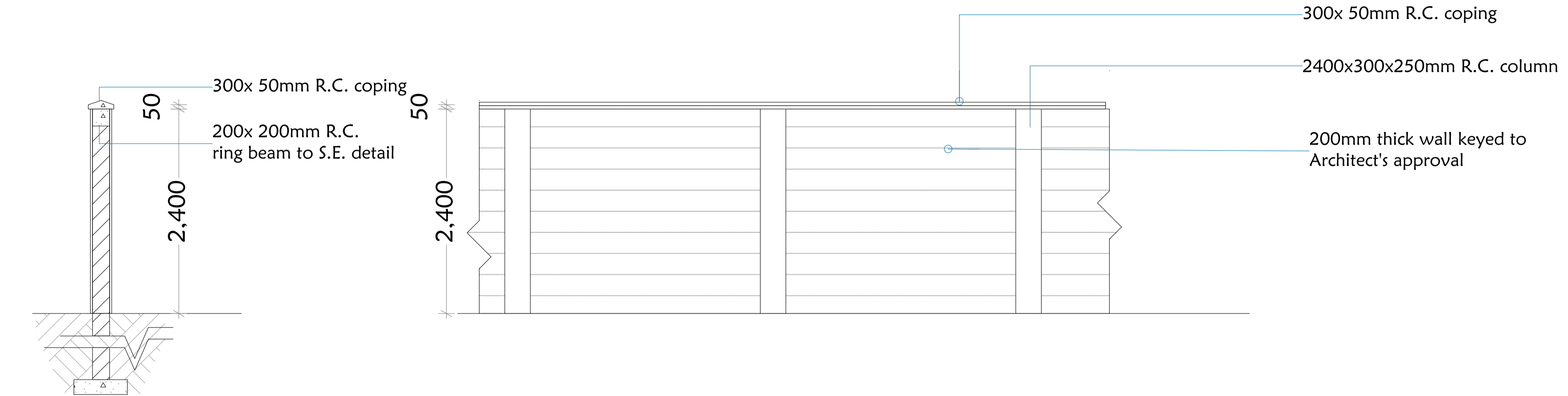

Boundary wall Section

Boundary wall Elevation

COMMERCIAL BLOCK

STUDENT HOUSING

GENERAL NOTES

1. This drawing to be read in conjunction with Engineers' drawings.
2. All dimensions are in mm unless otherwise specified.
3. Drawings are not to be scaled. Only figured dimensions should be used.
4. The contractor must check and verify all dimensions before commencement of work and if necessary confirm with the architect.

CONSTRUCTION

Approved anti-termite treatment & 1000 gauge polythene sheeting cover to be provided under all ground floor concrete slab on compacted hardcore to approval.
DPC to be 3ply bituminous felt to be provided under all walls.

STRUCTURAL

1. All Black cotton soil to be removed from below all building and paved surfaces
2. All reinforced concrete work will be in accordance with structural drawings.
3. Foundation depths to be determined on site to S.E approval
4. All walls less than 200mm thick to be reinforced with hoop iron at every alternate course.
5. All adjacent R.C work and masonry walls to be tied with strap irons at every course

MECHANICAL

1. All Plumbing and Drainage Work to comply with specifications
2. S.V.P denotes soil vent pipe and to be provided at the head of the drainage
3. Where drainage is shown under driveways and slabs, to be encased in 150mm thick concrete surround.
4. All underground foul and waste drain pipes shall be of PVC to comply with BS5255
5. All ICs within building area driveway and parking to have heavy duty, double-seal airtight covers and walls to be 200mm.
6. Minimum slope in the drain pipes to be 1%
7. No chases for pipes will be allowed in the slabs
8. Sleeves will be allowed with written approval from S.E.
9. No cutting of concrete without express approval of the Architect or S.E
10. All testing of pipes must be coordinated with electrical and any conflicts must be resolved before works begin
11. Permanent vents denoted as P.V to be provided as shown on plan.

ELECTRICAL

All conduits must be laid before plastering

PROJECT:

PROPOSED AFFORDABLE HOUSING DEVELOPMENT IN ALUPE UNIVERSITY

CLIENT:

Name: STATE DEPARTMENT FOR HOUSING AND URBAN DEVELOPMENT

Signature: _____ Date: _____

DRAWING TITLE:

SCALE:

DRAWN BY:

CHECKED BY:

Name: _____

Signature: _____ Date: _____

DATE:

MINISTRY OF LANDS, PUBLIC WORKS, HOUSING AND URBAN DEVELOPMENT

STATE DEPARTMENT FOR HOUSING & URBAN DEVELOPMENT



FOR THE GOVERNMENT OF THE REPUBLIC OF KENYA

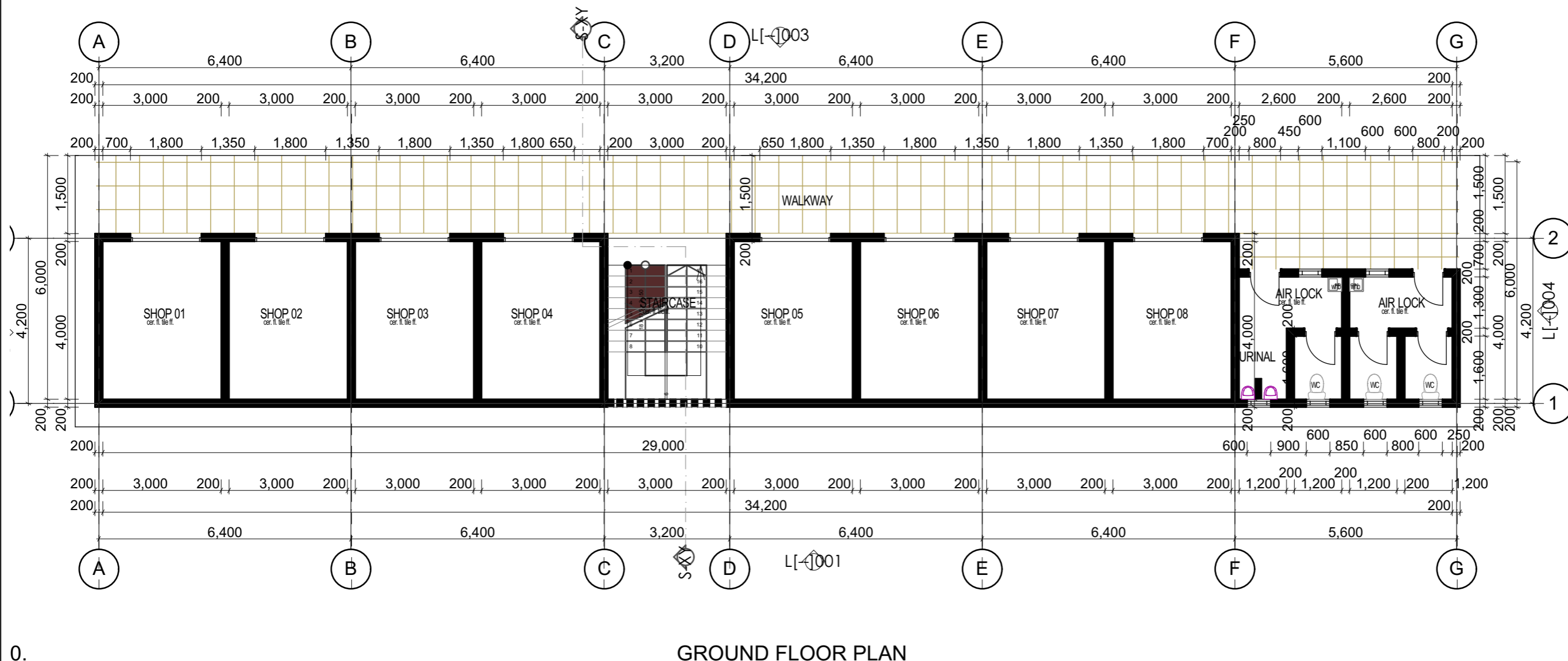

0.

GENERAL NOTES

1. This drawing to be read in conjunction with Engineers' drawings.
2. All dimensions are in mm unless otherwise specified.
3. Drawings are not to be scaled. Only figured dimensions should be used.
4. The contractor must check and verify all dimensions before commencement of work and if necessary confirm with the architect.

CONSTRUCTION

Approved anti-termite treatment & 1000 gauge polythene sheeting cover to be provided under all ground floor concrete slab on compacted hardcore to approval.
DPC to be 3ply bituminous felt to be provided under all walls.

STRUCTURAL

1. All Black cotton soil to be removed from below all building and paved surfaces
2. All reinforced concrete work will be in accordance with structural drawings.
3. Foundation depths to be determined on site to S.E approval
4. All walls less than 200mm thick to be reinforced with hoop iron at every alternate course.
5. All adjacent R.C work and masonry walls to be tied with strap irons at every course

MECHANICAL

1. All Plumbing and Drainage Work to comply with specifications
2. S.V.P denotes soil vent pipe and to be provided at the head of the drainage
3. Where drainage is shown under driveways and slabs, to be encased in 150mm thick concrete surround.
4. All underground foul and waste drain pipes shall be of PVC to comply with BS5255
5. All ICs within building area driveway and parking to have heavy duty, double-seal airtight covers and walls to be 200mm.
6. Minimum slope in the drain pipes to be 1%
7. No chases for pipes will be allowed in the slabs
8. Sleeves will be allowed with written approval from S.E.
9. No cutting of concrete without express approval of the Architect or S.E
10. All testing of pipes must be coordinated with electrical and any conflicts must be resolved before works begin
11. Permanent vents denoted as P.V to be provided as shown on plan.

ELECTRICAL

All conduits must be laid before plastering

PROJECT:

PROPOSED AFFORDABLE HOUSING DEVELOPMENT IN ALUPE UNIVERSITY

CLIENT:

Name: STATE DEPARTMENT FOR HOUSING AND URBAN DEVELOPMENT

Signature: _____ Date: _____

DRAWING TITLE:

SCALE:

DRAWN BY:

CHECKED BY:

Name: _____

Signature: _____ Date: _____

DATE:

MINISTRY OF LANDS, PUBLIC WORKS, HOUSING AND URBAN DEVELOPMENT

STATE DEPARTMENT FOR HOUSING & URBAN DEVELOPMENT



FOR THE GOVERNMENT OF THE REPUBLIC OF KENYA

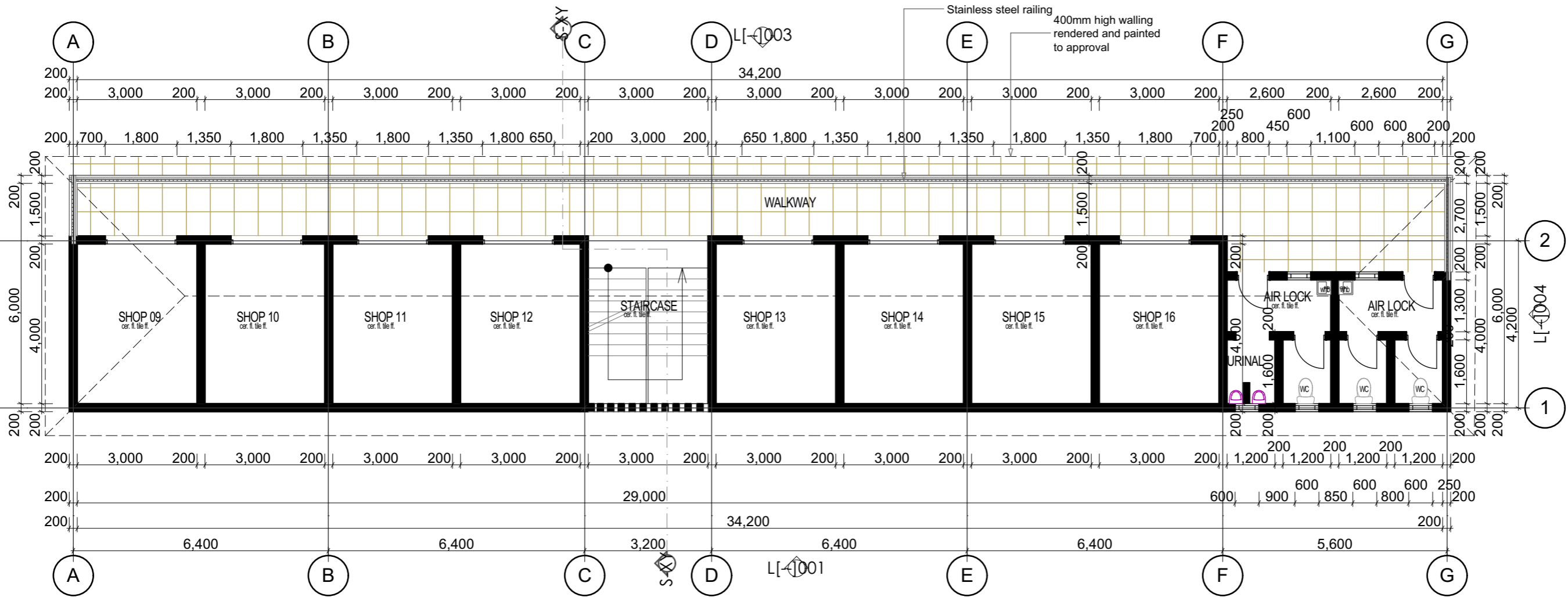

FIRST FLOOR PLAN

1.

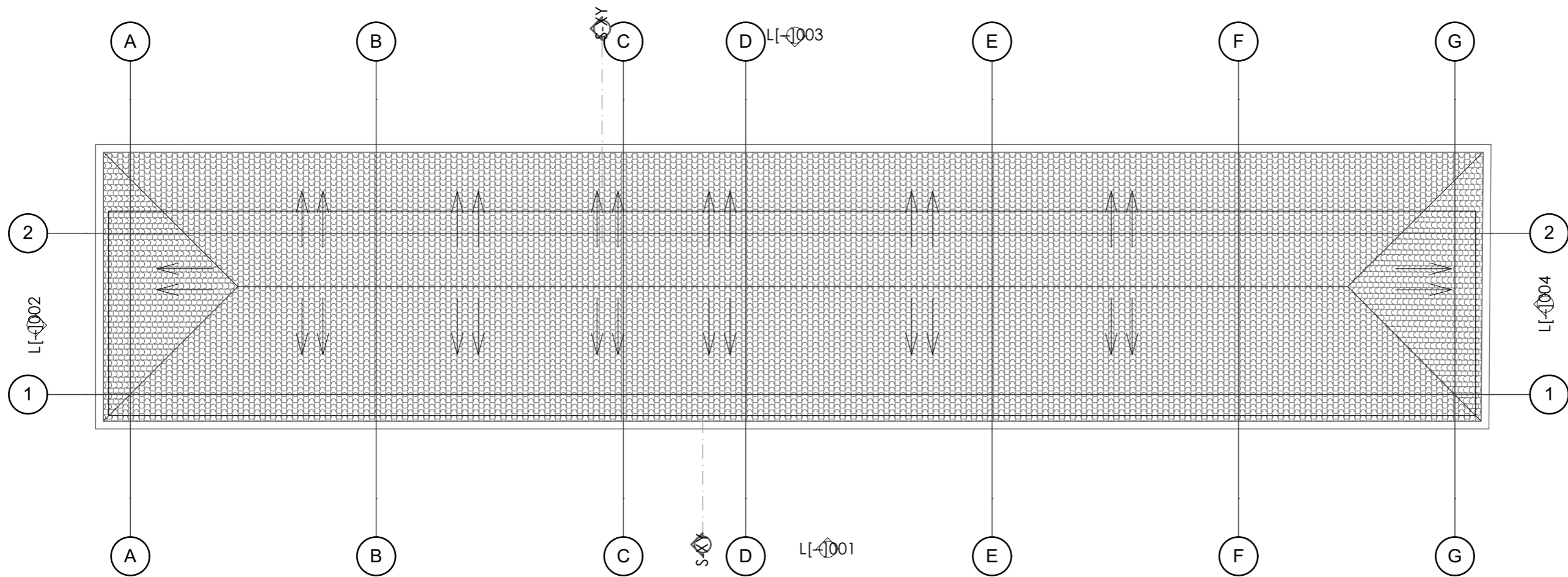

2.

ROOF PLAN

GENERAL NOTES

1. This drawing to be read in conjunction with Engineers' drawings.
2. All dimensions are in mm unless otherwise specified.
3. Drawings are not to be scaled. Only figured dimensions should be used.
4. The contractor must check and verify all dimensions before commencement of work and if necessary confirm with the architect.

CONSTRUCTION

Approved anti-termite treatment & 1000 gauge polythene sheeting cover to be provided under all ground floor concrete slab on compacted hardcore to approval.
DPC to be 3ply bituminous felt to be provided under all walls.

STRUCTURAL

1. All Black cotton soil to be removed from below all building and paved surfaces
2. All reinforced concrete work will be in accordance with structural drawings.
3. Foundation depths to be determined on site to S.E approval
4. All walls less than 200mm thick to be reinforced with hoop iron at every alternate course.
5. All adjacent R.C work and masonry walls to be tied with strap irons at every course

MECHANICAL

1. All Plumbing and Drainage Work to comply with specifications
2. S.V.P denotes soil vent pipe and to be provided at the head of the drainage
3. Where drainage is shown under driveways and slabs, to be encased in 150mm thick concrete surround.
4. All underground foul and waste drain pipes shall be of PVC to comply with BS5255
5. All ICs within building area driveway and parking to have heavy duty, double-seal airtight covers and walls to be 200mm.
6. Minimum slope in the drain pipes to be 1%
7. No chases for pipes will be allowed in the slabs
8. Sleeves will be allowed with written approval from S.E.
9. No cutting of concrete without express approval of the Architect or S.E
10. All testing of pipes must be coordinated with electrical and any conflicts must be resolved before works begin
11. Permanent vents denoted as P.V to be provided as shown on plan.

ELECTRICAL

All conduits must be laid before plastering

PROJECT:

PROPOSED AFFORDABLE HOUSING DEVELOPMENT IN ALUPE UNIVERSITY

CLIENT:

Name: STATE DEPARTMENT FOR HOUSING AND URBAN DEVELOPMENT

Signature: _____ Date: _____

DRAWING TITLE:

SCALE:

DRAWN BY:

CHECKED BY:

Name: _____

Signature: _____ Date: _____

DATE:

MINISTRY OF LANDS, PUBLIC WORKS, HOUSING AND URBAN DEVELOPMENT

STATE DEPARTMENT FOR HOUSING & URBAN DEVELOPMENT



FOR THE GOVERNMENT OF THE REPUBLIC OF KENYA

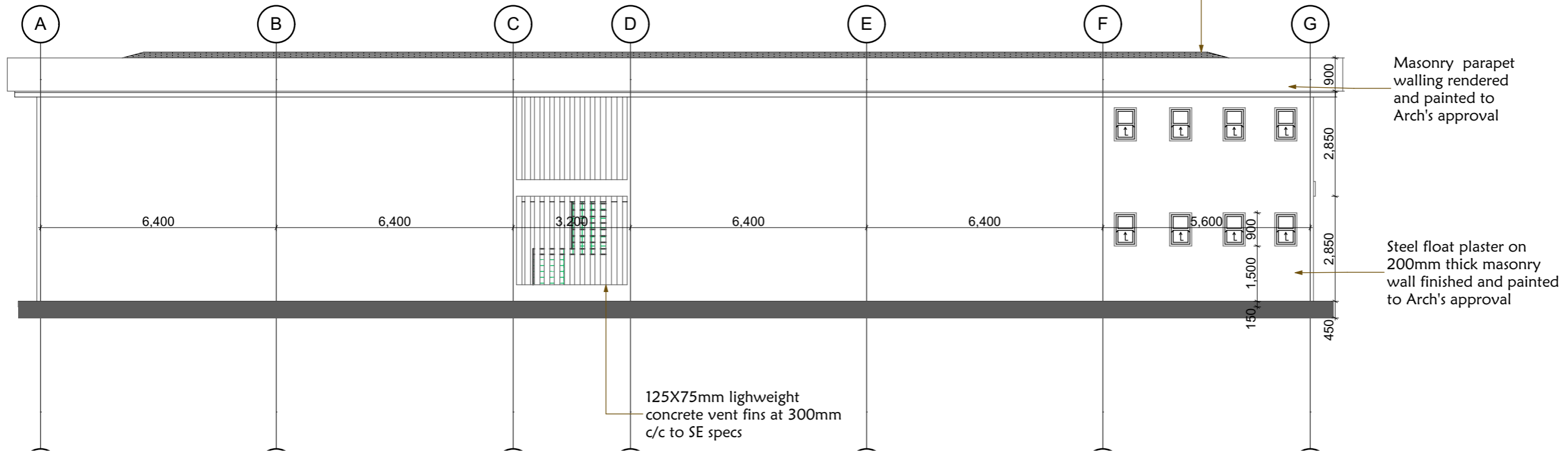

L[--]001

ELEVATION

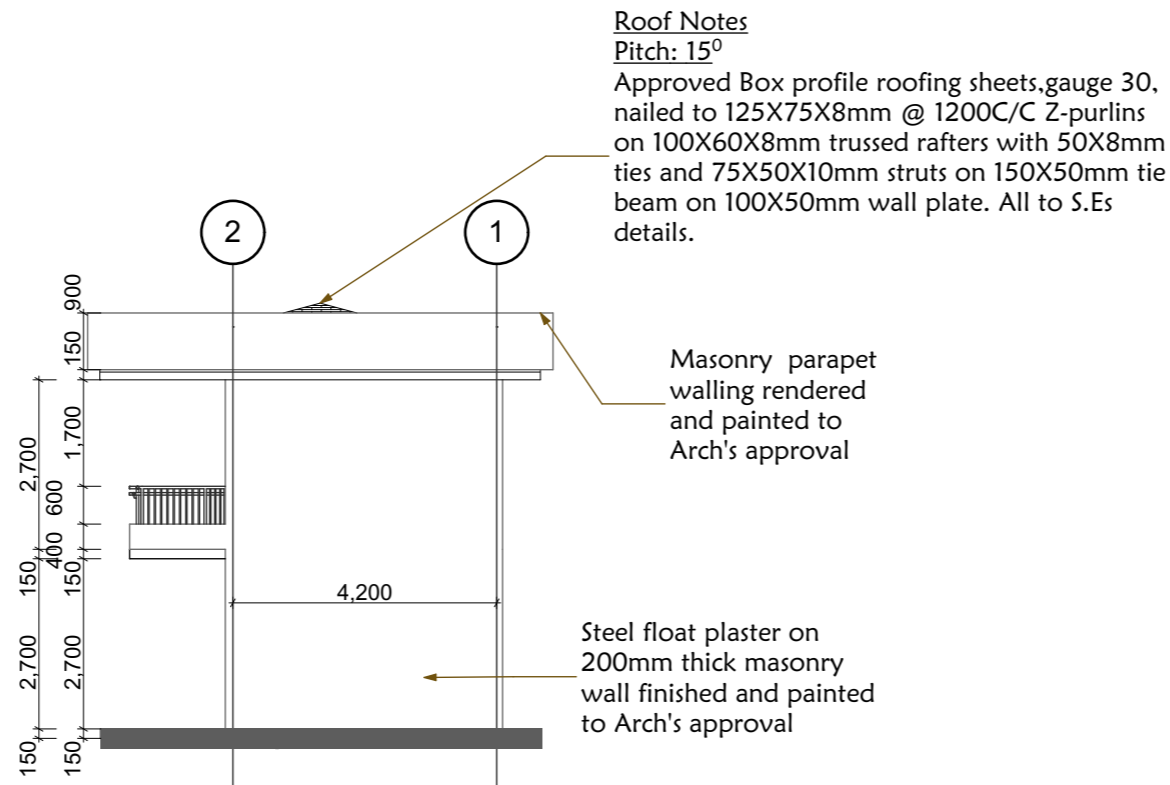

L[--]002

1:120

Roof Notes
Pitch: 15°

Approved Box profile roofing sheets, gauge 30, nailed to 125X75X8mm @ 1200C/C Z-purlins on 100X60X8mm trussed rafters with 50X8mm ties and 75X50X10mm struts on 150X50mm tie beam on 100X50mm wall plate. All to S.Es details.

Masonry parapet walling rendered and painted to Arch's approval

Steel float plaster on 200mm thick masonry wall finished and painted to Arch's approval

125X75mm lightweight concrete vent fins at 300mm c/c to SE specs

GENERAL NOTES

1. This drawing to be read in conjunction with Engineers' drawings.
2. All dimensions are in mm unless otherwise specified.
3. Drawings are not to be scaled. Only figured dimensions should be used.
4. The contractor must check and verify all dimensions before commencement of work and if necessary confirm with the architect.

CONSTRUCTION

Approved anti-termite treatment & 1000 gauge polythene sheeting cover to be provided under all ground floor concrete slab on compacted hardcore to approval. DPC to be 3ply bituminous felt to be provided under all walls.

STRUCTURAL

1. All Black cotton soil to be removed from below all building and paved surfaces
2. All reinforced concrete work will be in accordance with structural drawings.
3. Foundation depths to be determined on site to S.E approval
4. All walls less than 200mm thick to be reinforced with hoop iron at every alternate course.
5. All adjacent R.C work and masonry walls to be tied with strap irons at every course

MECHANICAL

1. All Plumbing and Drainage Work to comply with specifications
2. S.V.P denotes soil vent pipe and to be provided at the head of the drainage
3. Where drainage is shown under driveways and slabs, to be encased in 150mm thick concrete surround.
4. All underground foul and waste drain pipes shall be of PVC to comply with BS5255
5. All ICs within building area driveway and parking to have heavy duty, double-seal airtight covers and walls to be 200mm.
6. Minimum slope in the drain pipes to be 1%
7. No chases for pipes will be allowed in the slabs
8. Sleeves will be allowed with written approval from S.E.
9. No cutting of concrete without express approval of the Architect or S.E
10. All testing of pipes must be coordinated with electrical and any conflicts must be resolved before works begin
11. Permanent vents denoted as P.V to be provided as shown on plan.

ELECTRICAL

All conduits must be laid before plastering

PROJECT:

PROPOSED AFFORDABLE HOUSING DEVELOPMENT IN ALUPE UNIVERSITY

CLIENT:

Name: STATE DEPARTMENT FOR HOUSING AND URBAN DEVELOPMENT

Signature: _____ Date: _____

DRAWING TITLE:

SCALE:

DRAWN BY:

CHECKED BY:

Name: _____

Signature: _____ Date: _____

DATE:

MINISTRY OF LANDS, PUBLIC WORKS, HOUSING AND URBAN DEVELOPMENT

STATE DEPARTMENT FOR HOUSING & URBAN DEVELOPMENT



FOR THE GOVERNMENT OF THE REPUBLIC OF KENYA

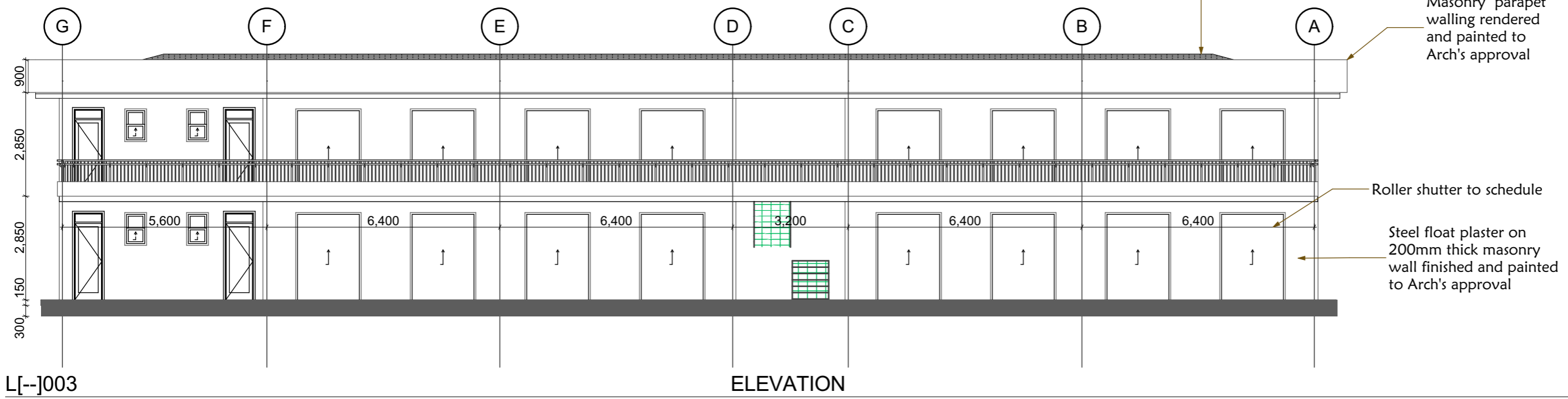

- GENERAL NOTES**
1. This drawing to be read in conjunction with Engineers' drawings.
 2. All dimensions are in mm unless otherwise specified.
 3. Drawings are not to be scaled. Only figured dimensions should be used.
 4. The contractor must check and verify all dimensions before commencement of work and if necessary confirm with the architect.
- CONSTRUCTION**
- Approved anti-termite treatment & 1000 gauge polythene sheeting cover to be provided under all ground floor concrete slab on compacted hardcore to approval.
DPC to be 3ply bituminous felt to be provided under all walls.
- STRUCTURAL**
1. All Black cotton soil to be removed from below all building and paved surfaces
 2. All reinforced concrete work will be in accordance with structural drawings.
 3. Foundation depths to be determined on site to S.E approval
 4. All walls less than 200mm thick to be reinforced with hoop iron at every alternate course.
 5. All adjacent R.C work and masonry walls to be tied with strap irons at every course
- MECHANICAL**
1. All Plumbing and Drainage Work to comply with specifications
 2. S.V.P denotes soil vent pipe and to be provided at the head of the drainage
 3. Where drainage is shown under driveways and slabs, to be encased in 150mm thick concrete surround.
 4. All underground foul and waste drain pipes shall be of PVC to comply with BS5255
 5. All ICs within building area driveway and parking to have heavy duty, double-seal airtight covers and walls to be 200mm.
 6. Minimum slope in the drain pipes to be 1%
 7. No chases for pipes will be allowed in the slabs
 8. Sleeves will be allowed with written approval from S.E.
 9. No cutting of concrete without express approval of the Architect or S.E
 10. All testing of pipes must be coordinated with electrical and any conflicts must be resolved before works begin
 11. Permanent vents denoted as P.V to be provided as shown on plan.
- ELECTRICAL**
- All conduits must be laid before plastering

L[--]003

ELEVATION

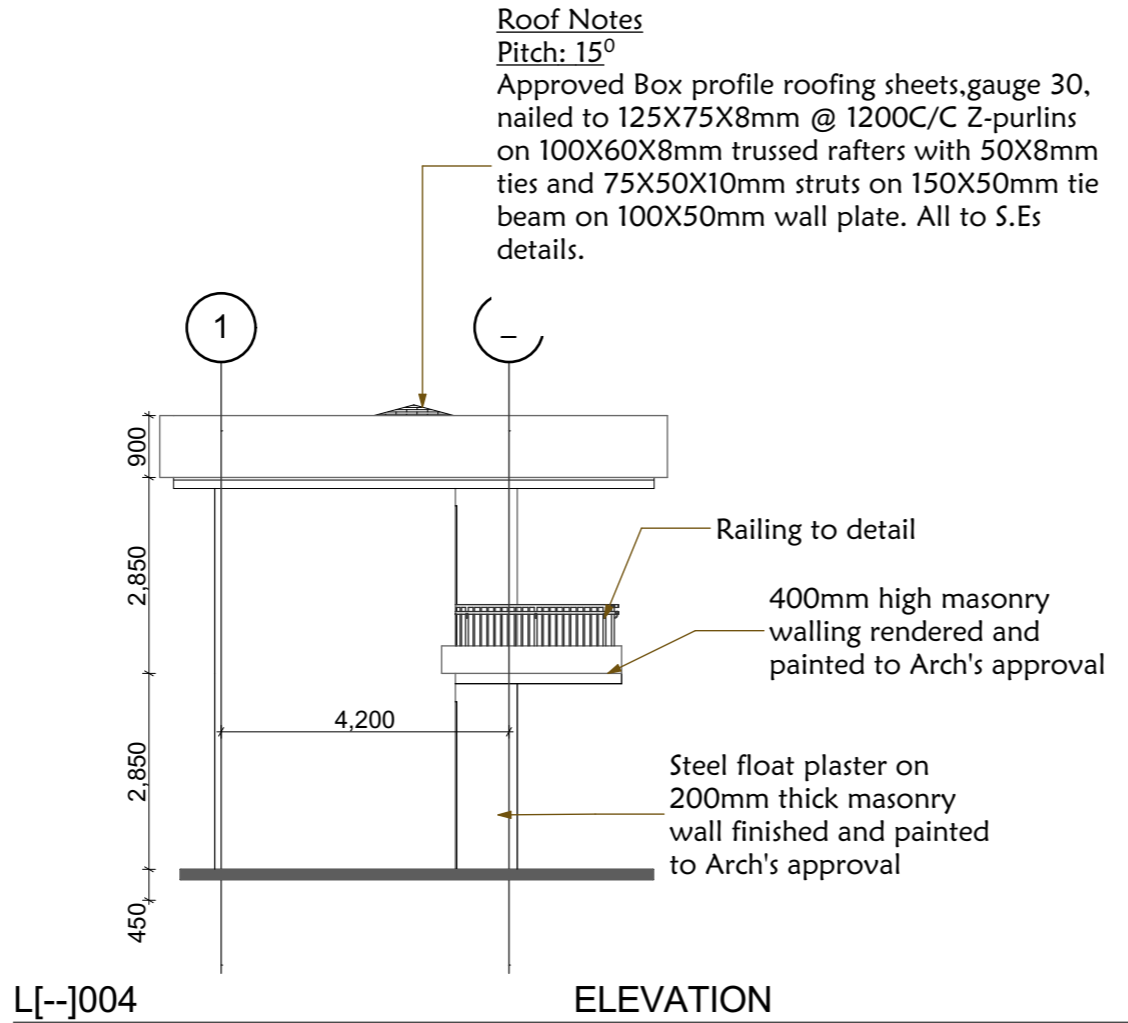

L[--]004

ELEVATION

PROJECT:
PROPOSED AFFORDABLE HOUSING
DEVELOPMENT IN ALUPE UNIVERSITY

CLIENT:
Name: STATE DEPARTMENT FOR HOUSING AND
URBAN DEVELOPMENT
Signature: _____ Date: _____

DRAWING TITLE:

SCALE:

DRAWN BY:

CHECKED BY:
Name: _____
Signature: _____ Date: _____

DATE:

MINISTRY OF LANDS, PUBLIC WORKS,
HOUSING AND URBAN DEVELOPMENT
STATE DEPARTMENT FOR HOUSING & URBAN
DEVELOPMENT



FOR THE GOVERNMENT OF THE
REPUBLIC OF KENYA

CLUB HOUSE & POOL

STUDENT HOUSING

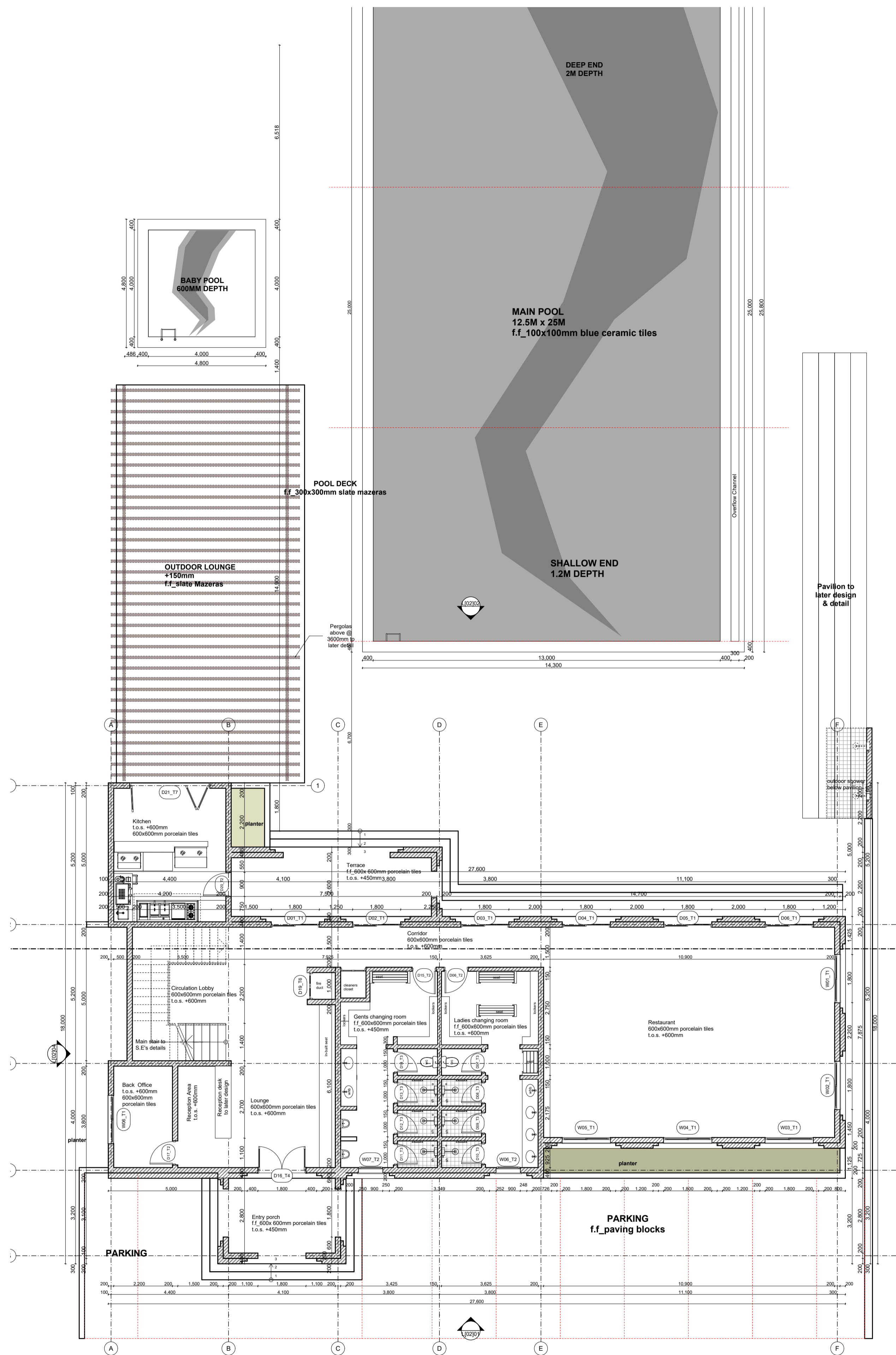

GROUND FLOOR PLAN
1:100

GENERAL NOTES

1. This drawing to be read in conjunction with Engineers' drawings.
2. All dimensions are in mm unless otherwise specified.
3. Drawings are not to be scaled. Only figured dimensions should be used.
4. The contractor must check and verify all dimensions before commencement of work and if necessary confirm with the architect.

CONSTRUCTION

Approved anti-termite treatment & 1000 gauge polythene sheeting cover to be provided under all ground floor concrete slab on compacted hardcore to approval.
DPC to be 3ply bituminous felt to be provided under all walls.

STRUCTURAL

1. All Black cotton soil to be removed from below all building and paved surfaces
2. All reinforced concrete work will be in accordance with structural drawings.
3. Foundation depths to be determined on site to S.E approval
4. All walls less than 200mm thick to be reinforced with hoop iron at every alternate course.
5. All adjacent R.C work and masonry walls to be tied with strap irons at every course

MECHANICAL

1. All Plumbing and Drainage Work to comply with specifications
2. S.V.P denotes soil vent pipe and to be provided at the head of the drainage
3. Where drainage is shown under driveways and slabs, to be encased in 150mm thick concrete surround.
4. All underground foul and waste drain pipes shall be of PVC to comply with BS5255
5. All ICs within building area, driveway and parking to have heavy duty, double-seal airtight covers and walls to be 200mm.
6. Minimum slope in the drain pipes to be 1%
7. No chases for pipes will be allowed in the slabs
8. Sleeves will be allowed with written approval from S.E.
9. No cutting of concrete without express approval of the Architect or S.E
10. All testing of pipes must be coordinated with electrical and any conflicts must be resolved before works begin
11. Permanent vents denoted as P.V to be provided as shown on plan.

ELECTRICAL

All conduits must be laid before plastering

PROJECT:

PROPOSED AFFORDABLE HOUSING DEVELOPMENT IN ALUPE UNIVERSITY

CLIENT:

Name: STATE DEPARTMENT FOR HOUSING AND URBAN DEVELOPMENT

Signature: _____ Date: _____

DRAWING TITLE:

CLUB HOUSE_GROUND FLOOR PLAN LAYOUT

SCALE:1:100

Paper Size **A1**

DRAWN BY:

ML

CHECKED BY:

Name: _____

Signature: _____ Date: _____

DATE:

MINISTRY OF LANDS, PUBLIC WORKS, HOUSING AND URBAN DEVELOPMENT

STATE DEPARTMENT FOR HOUSING & URBAN DEVELOPMENT



FOR THE GOVERNMENT OF THE REPUBLIC OF KENYA

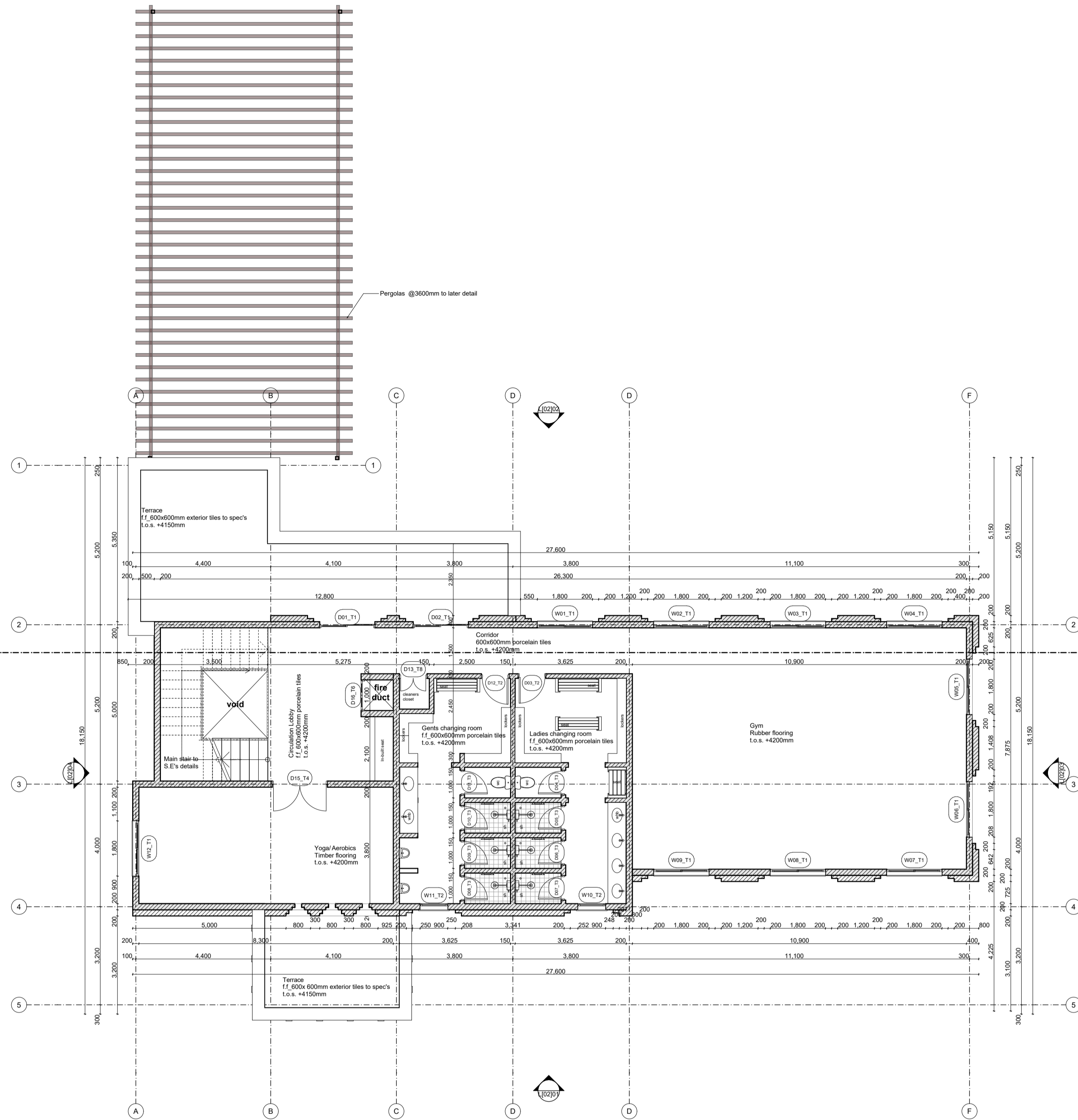

L1-102 FIRST FLOOR PLAN
SCALE 1:100

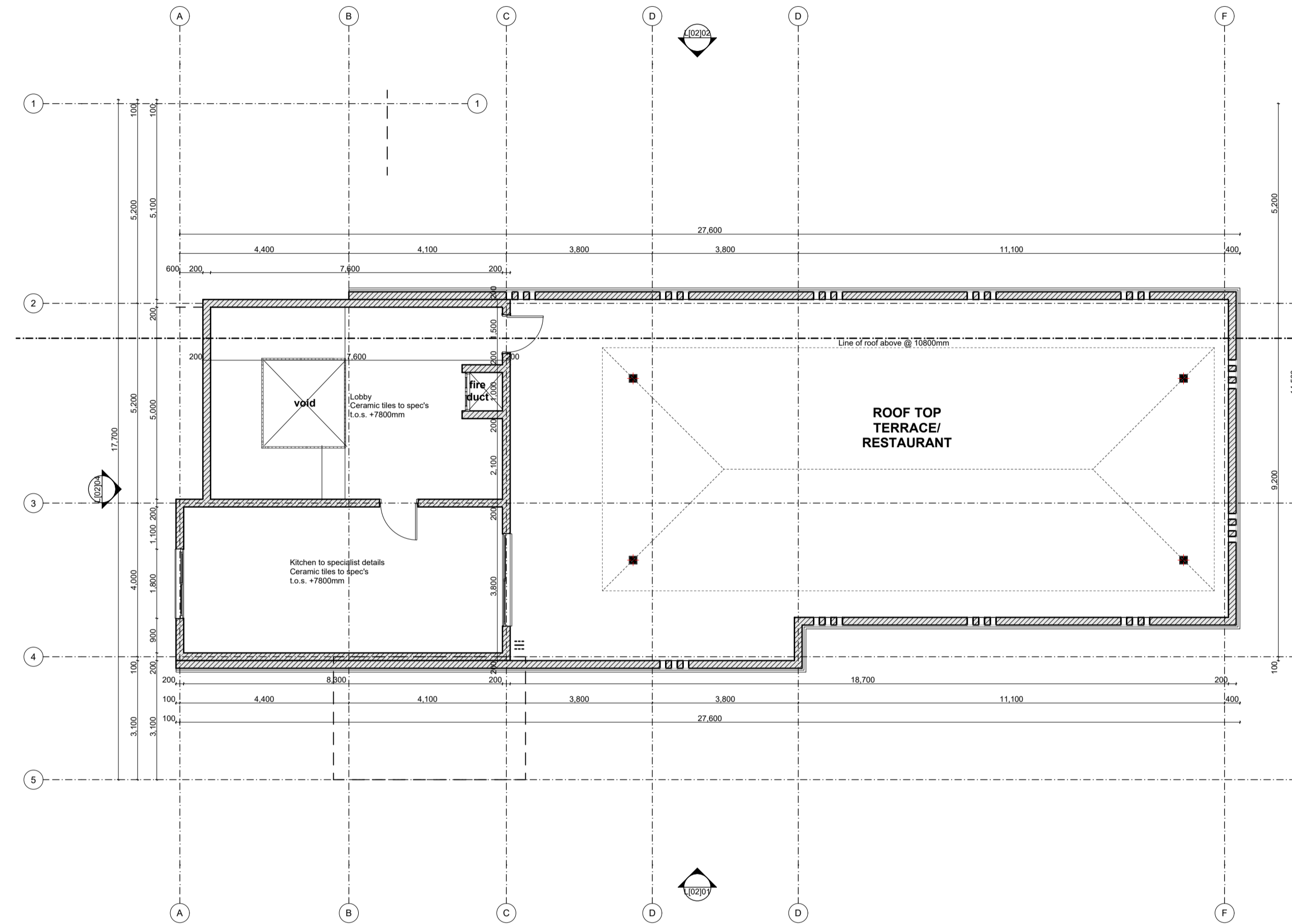

L1-103 SECOND FLOOR PLAN
SCALE 1:100

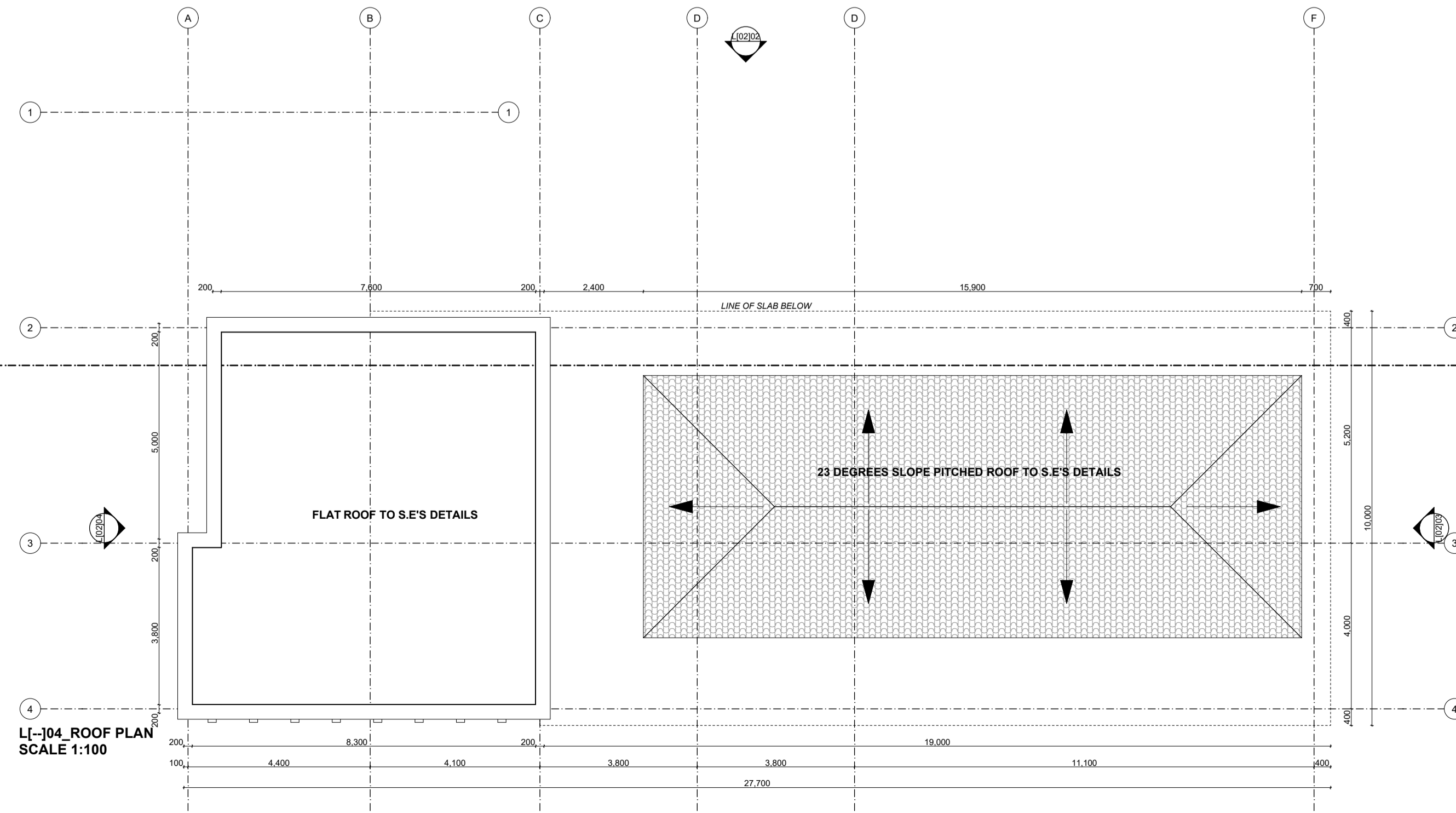

L1-104 ROOF PLAN
SCALE 1:100

GENERAL NOTES

1. This drawing to be read in conjunction with Engineers' drawings.
2. All dimensions are in mm unless otherwise specified.
3. Drawings are not to be scaled. Only figured dimensions should be used.
4. The contractor must check and verify all dimensions before commencement of work and if necessary confirm with the architect.

CONSTRUCTION

Approved anti-termite treatment & 1000 gauge polythene sheeting cover to be provided under all ground floor concrete slab on compacted hardcore to approval.
DPC to be 3ply bituminous felt to be provided under all walls.

STRUCTURAL

1. All Black cotton soil to be removed from below all building and paved surfaces
2. All reinforced concrete work will be in accordance with structural drawings.
3. Foundation depths to be determined on site to S.E approval
4. All walls less than 200mm thick to be reinforced with hoop iron at every alternate course.
5. All adjacent R.C work and masonry walls to be tied with strap irons at every course

MECHANICAL

1. All Plumbing and Drainage Work to comply with specifications
2. S.V.P denotes soil vent pipe and to be provided at the head of the drainage
3. Where drainage is shown under driveways and slabs, to be encased in 150mm thick concrete surround.
4. All underground foul and waste drain pipes shall be of PVC to comply with BS5255
5. All ICs within building area, driveway and parking to have heavy duty, double-seal airtight covers and walls to be 200mm.
6. Minimum slope in the drain pipes to be 1%
7. No chases for pipes will be allowed in the slabs
8. Sleeves will be allowed with written approval from S.E.
9. No cutting of concrete without express approval of the Architect or S.E
10. All testing of pipes must be coordinated with electrical and any conflicts must be resolved before works begin
11. Permanent vents denoted as P.V to be provided as shown on plan.

ELECTRICAL

All conduits must be laid before plastering

PROJECT:

PROPOSED AFFORDABLE HOUSING DEVELOPMENT IN ALUPE UNIVERSITY

CLIENT:

Name: STATE DEPARTMENT FOR HOUSING AND URBAN DEVELOPMENT

Signature: _____ Date: _____

DRAWING TITLE:

CLUB HOUSE, FIRST, SECOND & ROOF FLOOR PLAN LAYOUT

SCALE:1:100

Paper Size **A1**

DRAWN BY:

ML

CHECKED BY:

Name: _____

Signature: _____ Date: _____

DATE:

MINISTRY OF LANDS, PUBLIC WORKS, HOUSING AND URBAN DEVELOPMENT

STATE DEPARTMENT FOR HOUSING & URBAN DEVELOPMENT



FOR THE GOVERNMENT OF THE REPUBLIC OF KENYA

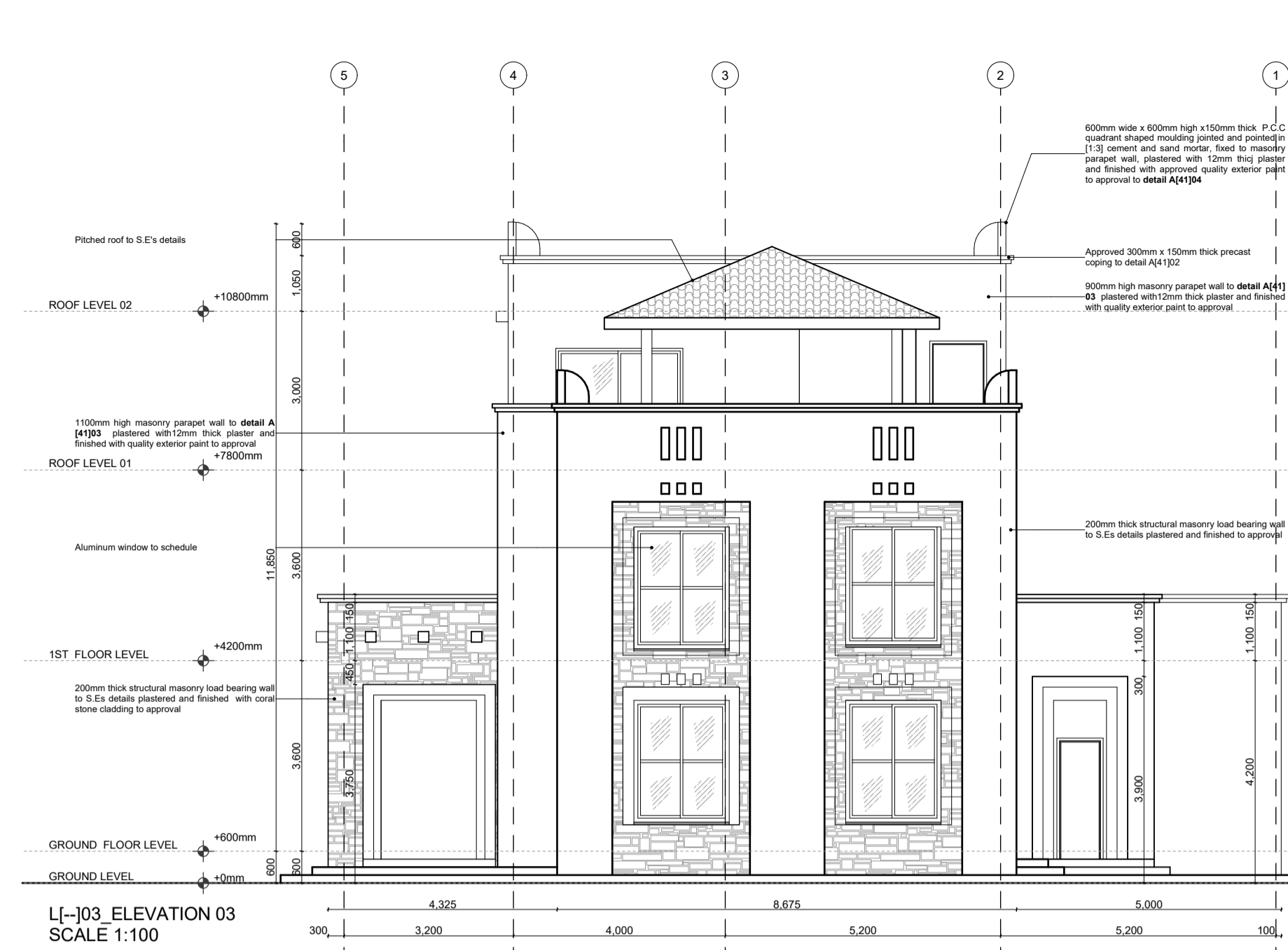
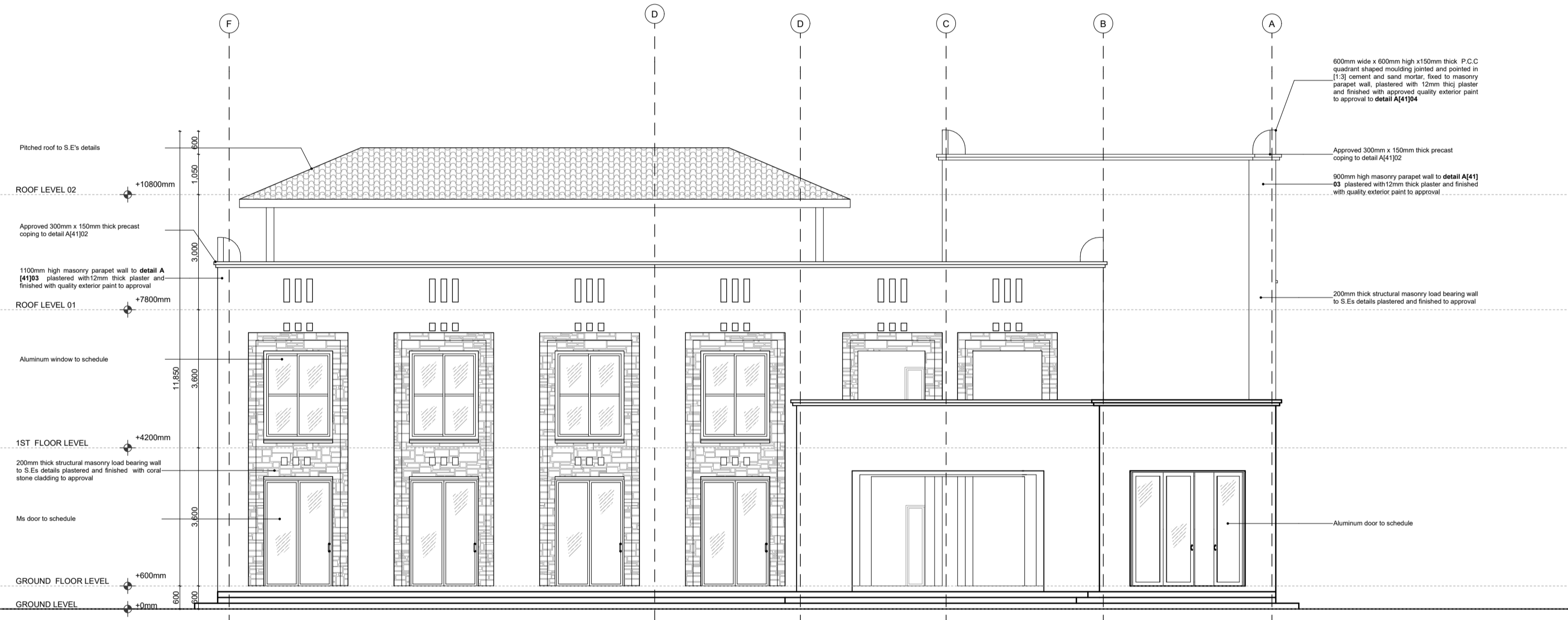
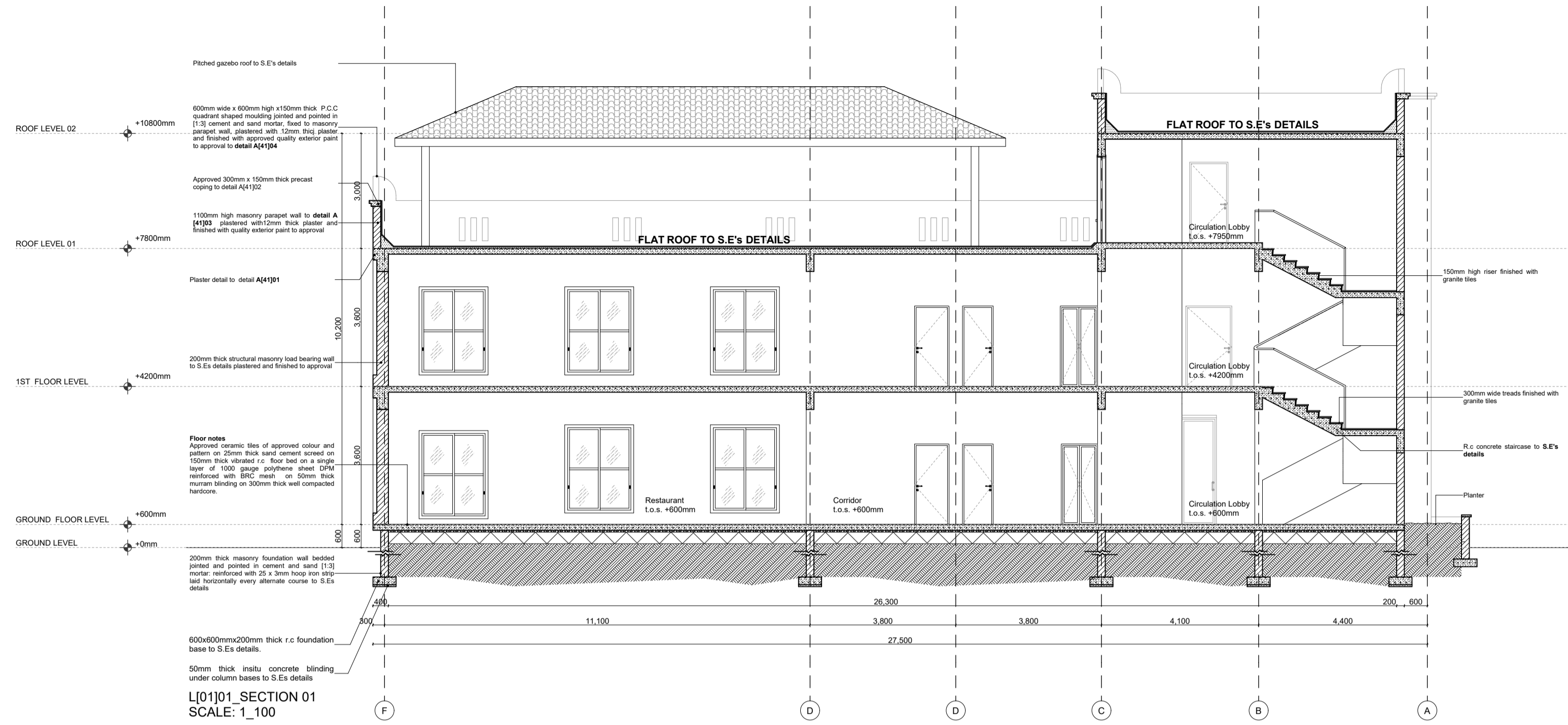

GENERAL NOTES

1. This drawing to be read in conjunction with Engineers' drawings.
2. All dimensions are in mm unless otherwise stated.
3. Drawings are not to be scaled. Only figured dimensions should be used.
4. The contractor must check and verify all dimensions before commencement of work and if necessary confirm with the architect.

CONSTRUCTION

Approved anti-termite treatment & 1000 gauge polythene sheeting cover to be provided under all ground floor concrete slab on compacted hardcore to approval.
DPC to be 3ply bituminous felt to be provided under all walls.

STRUCTURAL

1. All Black cotton soil to be removed from below all building and paved surfaces
2. All reinforced concrete work will be in accordance with structural drawings.
3. Foundation depths to be determined on site to S.E approval
4. All walls less than 200mm thick to be reinforced with hoop iron at every alternate course.
5. All adjacent R.C work and masonry walls to be tied with strap irons at every course

MECHANICAL

1. All Plumbing and Drainage Work to comply with specifications
2. S.V.P denotes soil vent pipe and to be provided at the head of the drainage
3. Where drainage is shown under driveways and slabs, to be encased in 150mm thick concrete surround.
4. All underground foul and waste drain pipes shall be of PVC to comply with BS5255
5. All ICs within building area, driveway and parking to have heavy duty, double-seal airtight covers and walls to be 200mm.
6. Minimum slope in the drain pipes to be 1%
7. No chases for pipes will be allowed in the slabs
8. Sleeves will be allowed with written approval on S.E.
9. No cutting of concrete without express approval of the Architect or S.E
10. All testing of pipes must be coordinated with electrical and any conflicts must be resolved before works begin
11. Permanent vents denoted as P.V to be provided as shown on plan.

ELECTRICAL

All conduits must be laid before plastering

PROJECT:

PROPOSED AFFORDABLE HOUSING DEVELOPMENT IN ALUPE UNIVERSITY

CLIENT:

Name: STATE DEPARTMENT FOR HOUSING AND URBAN DEVELOPMENT

Signature: _____ Date: _____

DRAWING TITLE:

CLUB HOUSE_Sections & Elevations

SCALE:1:100

Paper Size **A1**

DRAWN BY:

ML

CHECKED BY:

Name: _____

Signature: _____ Date: _____

DATE:

MINISTRY OF LANDS, PUBLIC WORKS, HOUSING AND URBAN DEVELOPMENT

STATE DEPARTMENT FOR HOUSING & URBAN DEVELOPMENT



FOR THE GOVERNMENT OF THE REPUBLIC OF KENYA

STUDENTS CENTRE

STUDENT HOUSING

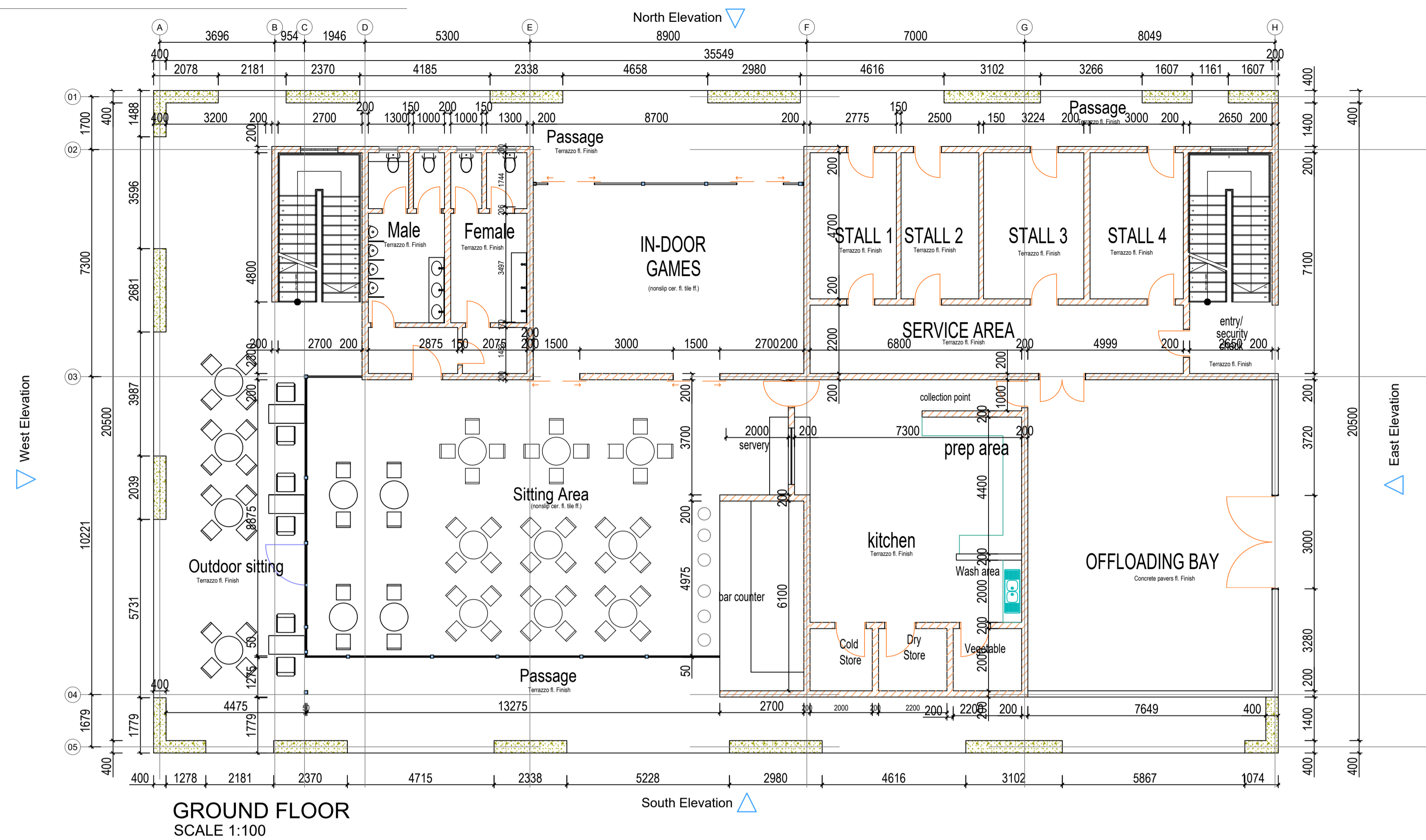

GROUND FLOOR
SCALE 1:100

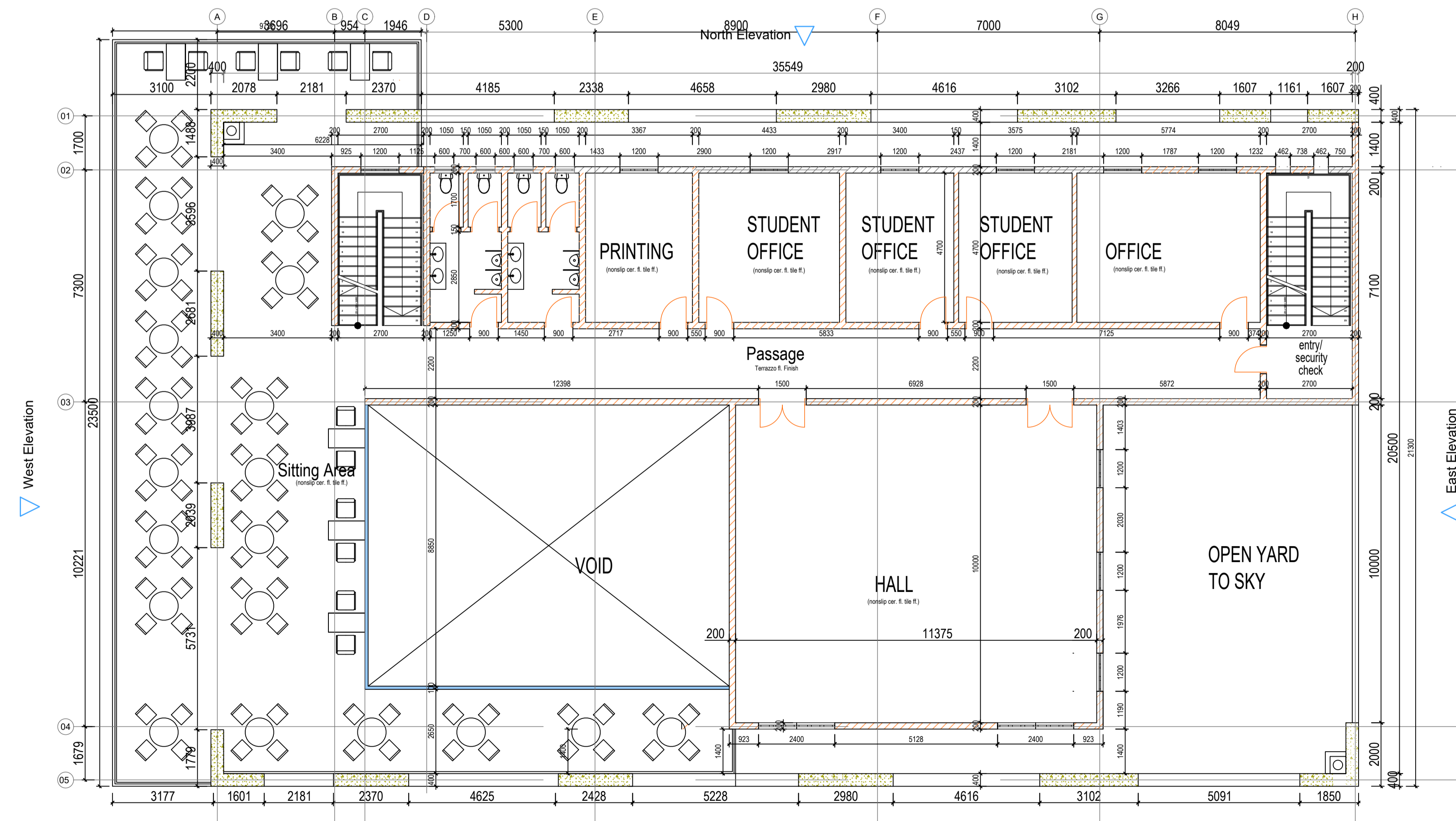

FIRST FLOOR
SCALE 1:100

GENERAL NOTES

1. This drawing to be read in conjunction with Engineers' drawings.
2. All dimensions are in mm unless otherwise specified.
3. Drawings are not to be scaled. Only figured dimensions should be used.
4. The contractor must check and verify all dimensions before commencement of work and if necessary confirm with the architect.

CONSTRUCTION

Approved anti-termite treatment & 1000 gauge polythene sheeting cover to be provided under all ground floor concrete slab on compacted hardcore to approval.
DPC to be 3ply bituminous felt to be provided under all walls.

STRUCTURAL

1. All Black cotton soil to be removed from below all building and paved surfaces
2. All reinforced concrete work will be in accordance with structural drawings.
3. Foundation depths to be determined on site to S.E approval
4. All walls less than 200mm thick to be reinforced with hoop iron at every alternate course.
5. All adjacent R.C work and masonry walls to be tied with strap irons at every course

MECHANICAL

1. All Plumbing and Drainage Work to comply with specifications
2. S.V.P denotes soil vent pipe and to be provided at the head of the drainage
3. Where drainage is shown under driveways and slabs, to be encased in 150mm thick concrete surround.
4. All underground foul and waste drain pipes shall be of PVC to comply with BS 5255
5. All ICs within building area, driveway and parking to have heavy duty, double-seal airtight covers and walls to be 200mm.
6. Minimum slope in the drain pipes to be 1%
7. No chases for pipes will be allowed in the slabs
8. Sleeves will be allowed with written approval from S.E.
9. No cutting of concrete without express approval of the Architect or S.E
10. All testing of pipes must be coordinated with electrical and any conflicts must be resolved before works begin
11. Permanent vents denoted as P.V to be provided as shown on plan.

ELECTRICAL

All conduits must be laid before plastering

PROJECT:

PROPOSED STUDENT HOUSING DEVELOPMENT
ALUPE UNIVERSITY, BUSIA COUNTY

CLIENT:

Name: STATE DEPARTMENT FOR HOUSING AND URBAN DEVELOPMENT

Signature: _____ Date: _____

DRAWING TITLE: STUDENT CENTRE

GROUND & FIRST FLOOR PLANS

SCALE:

DRAWN BY:

CHECKED BY:

Name: _____

Signature: _____ Date: _____

DATE:

MINISTRY OF LANDS, PUBLIC WORKS,
HOUSING AND URBAN DEVELOPMENT
STATE DEPARTMENT FOR HOUSING & URBAN DEVELOPMENT



FOR THE GOVERNMENT OF THE
REPUBLIC OF KENYA



elevation 01



elevation 02

elevation 03

elevation 04

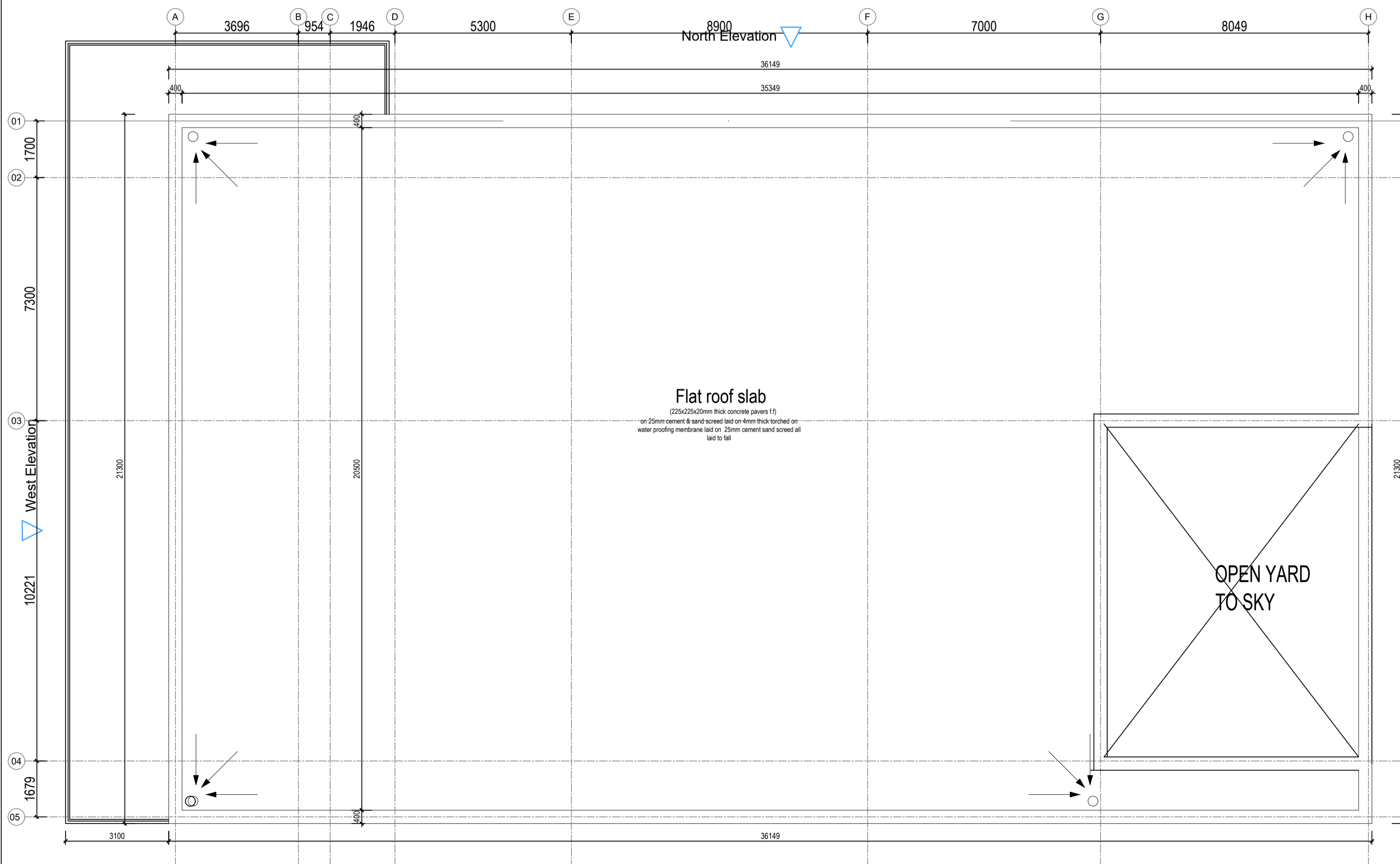

ROOF PLAN
SCALE 1:100

South Elevation



GENERAL NOTES

1. This drawing to be read in conjunction with Engineers' drawings.
2. All dimensions are in mm unless otherwise specified.
3. Drawings are not to be scaled. Only figured dimensions should be used.
4. The contractor must check and verify all dimensions before commencement of work and if necessary confirm with the architect.

CONSTRUCTION

Approved anti-termite treatment & 1000 gauge polythene sheeting cover to be provided under all ground floor concrete slab on compacted hardcore to approval.
DPC to be 3ply bituminous felt to be provided under all walls.

STRUCTURAL

1. All Black cotton soil to be removed from below all building and paved surfaces
2. All reinforced concrete work will be in accordance with structural drawings.
3. Foundation depths to be determined on site to S.E approval
4. All walls less than 200mm thick to be reinforced with hoop iron at every alternate course.
5. All adjacent R.C work and masonry walls to be tied with strap irons at every course

MECHANICAL

1. All Plumbing and Drainage Work to comply with specifications
2. S.V.P denotes soil vent pipe and to be provided at the head of the drainage
3. Where drainage is shown under driveways and slabs, to be encased in 150mm thick concrete surround.
4. All underground foul and waste drain pipes shall be of PVC to comply with BS 5255
5. All ICs within building area, driveway and parking to have heavy duty, double-seal airtight covers and walls to be 200mm.
6. Minimum slope in the drain pipes to be 1%
7. No chases for pipes will be allowed in the slabs
8. Sleeves will be allowed with written approval from S.E.
9. No cutting of concrete without express approval of the Architect or S.E
10. All testing of pipes must be coordinated with electrical and any conflicts must be resolved before works begin
11. Permanent vents denoted as P.V to be provided as shown on plan.

ELECTRICAL

All conduits must be laid before plastering

PROJECT:

PROPOSED STUDENT HOUSING DEVELOPMENT
ALUPE UNIVERSITY, BUSIA COUNTY

CLIENT:

Name: STATE DEPARTMENT FOR HOUSING AND URBAN DEVELOPMENT

Signature: _____ Date: _____

DRAWING TITLE: STUDENT CENTRE
ROOF & ELEVATIONS

SCALE:

DRAWN BY:

CHECKED BY:

Name: _____

Signature: _____ Date: _____

DATE:

MINISTRY OF LANDS, PUBLIC WORKS,
HOUSING AND URBAN DEVELOPMENT

STATE DEPARTMENT FOR HOUSING & URBAN
DEVELOPMENT



FOR THE GOVERNMENT OF THE
REPUBLIC OF KENYA

GATE HOUSE

STUDENT HOUSING

ELEV.
02

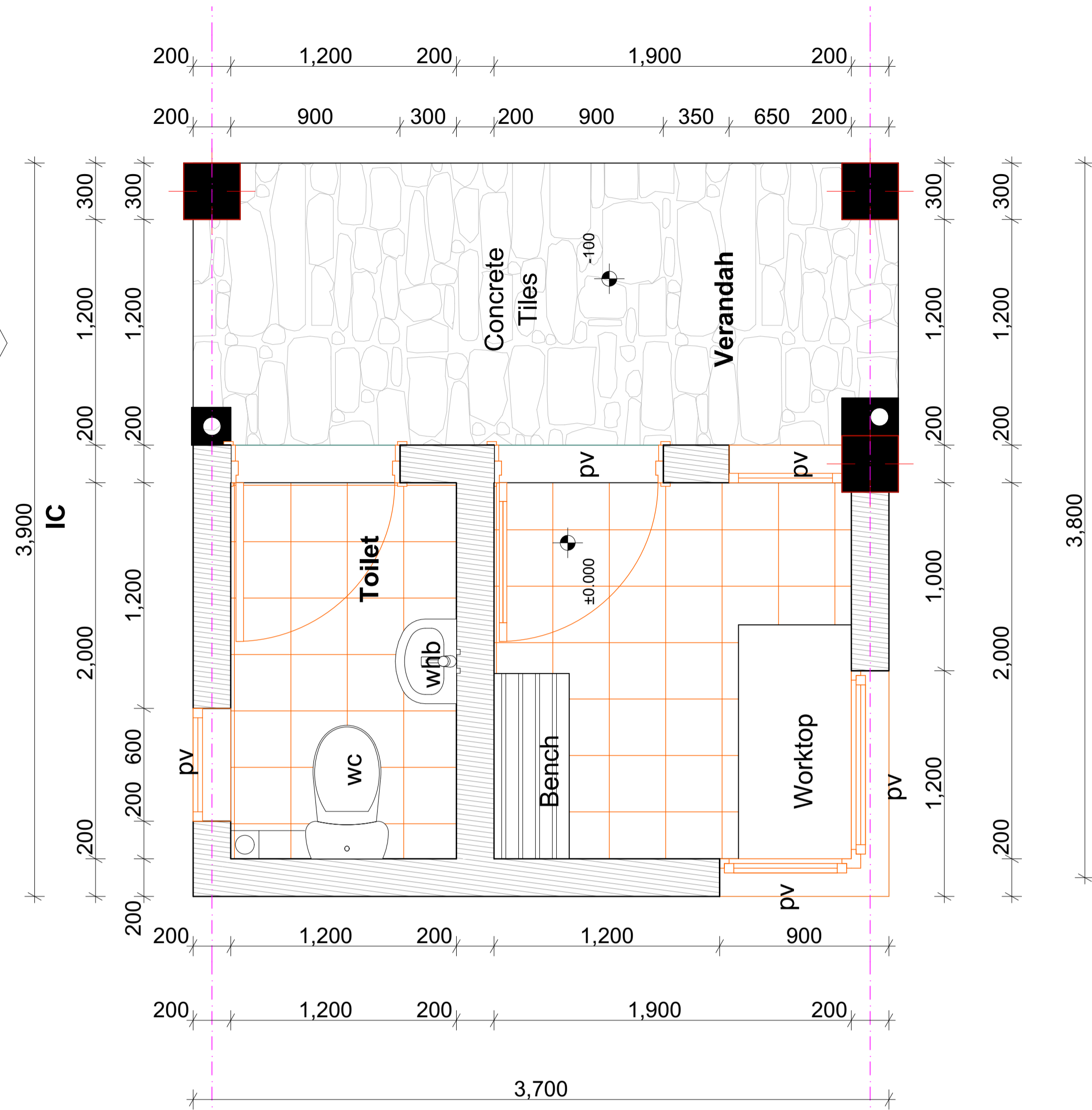

GUARD HOUSE DETAIL
[FLOOR PLAN]

- Mahogany T&G external door to schedule
- 100mm dia. pvc floor trap
- Anodized aluminium cased window to schedule
- 150mm High concrete mould encasing sewer pipe connecting to SVP to M&E Eng. specification

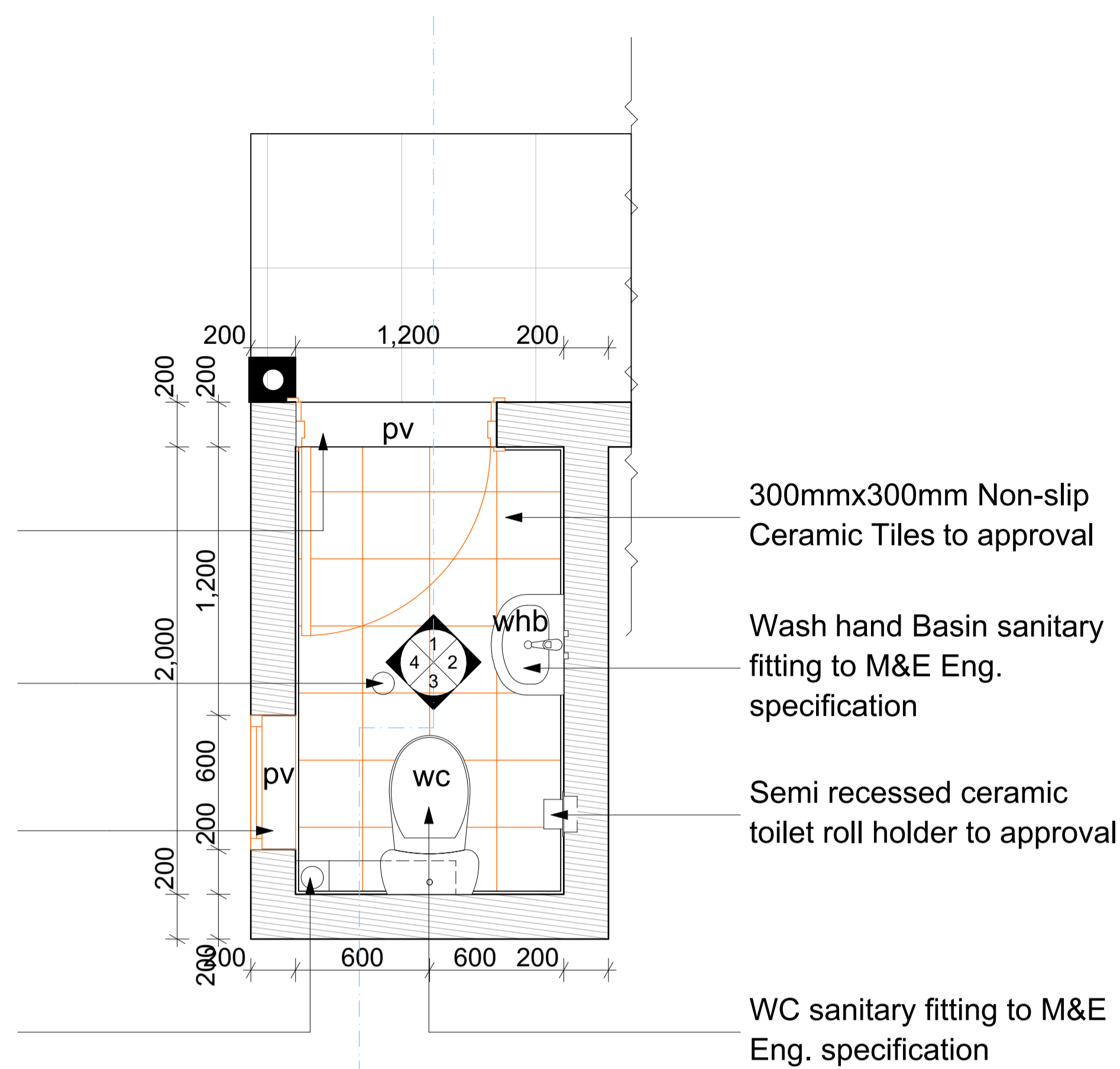

GUARD HOUSE TOILET DETAIL 01
[FLOOR PLAN]

- 300mmx300mm Non-slip Ceramic Tiles to approval
- Wash hand Basin sanitary fitting to M&E Eng. specification
- Semi recessed ceramic toilet roll holder to approval
- WC sanitary fitting to M&E Eng. specification

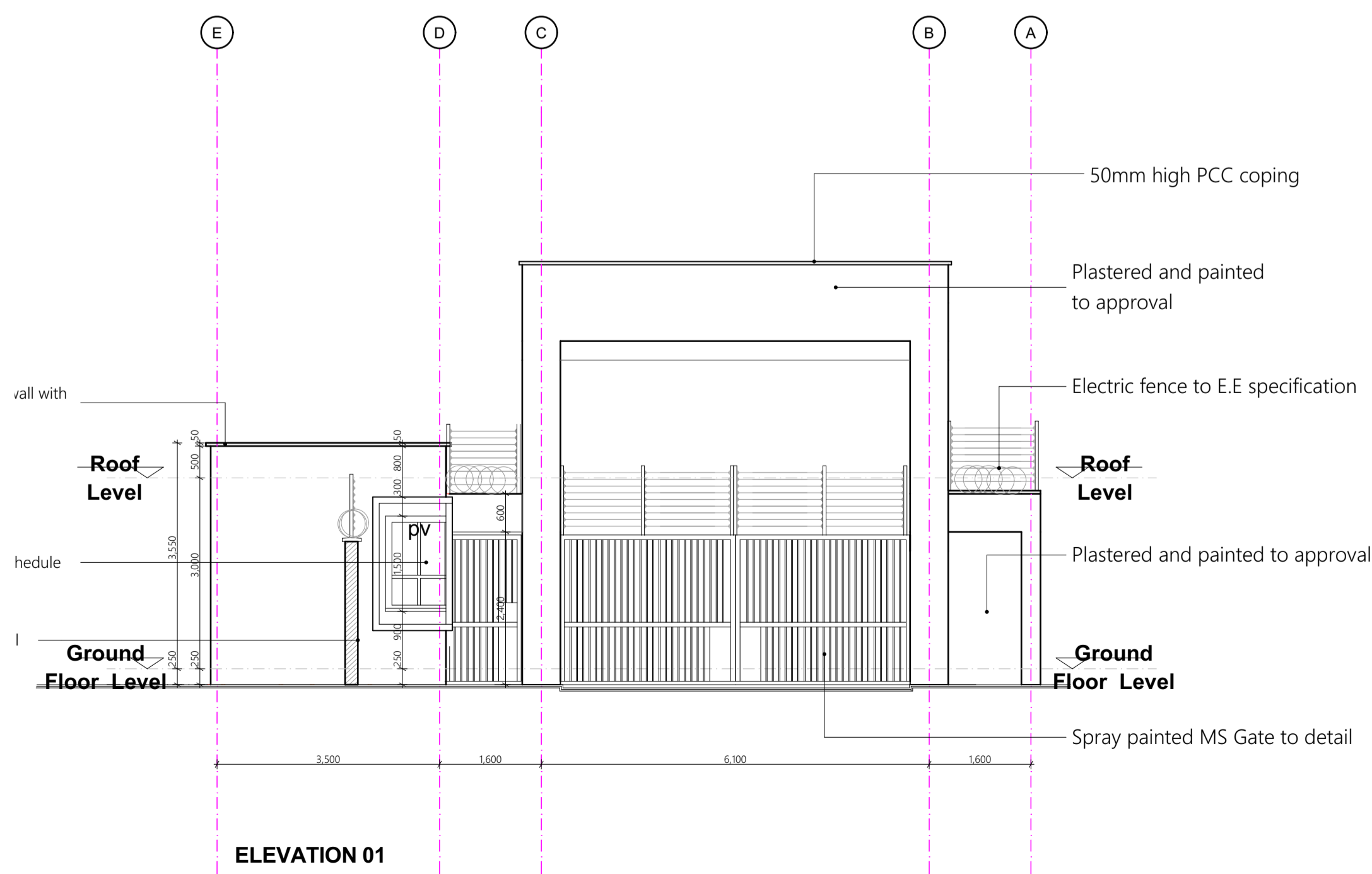

ELEVATION 01

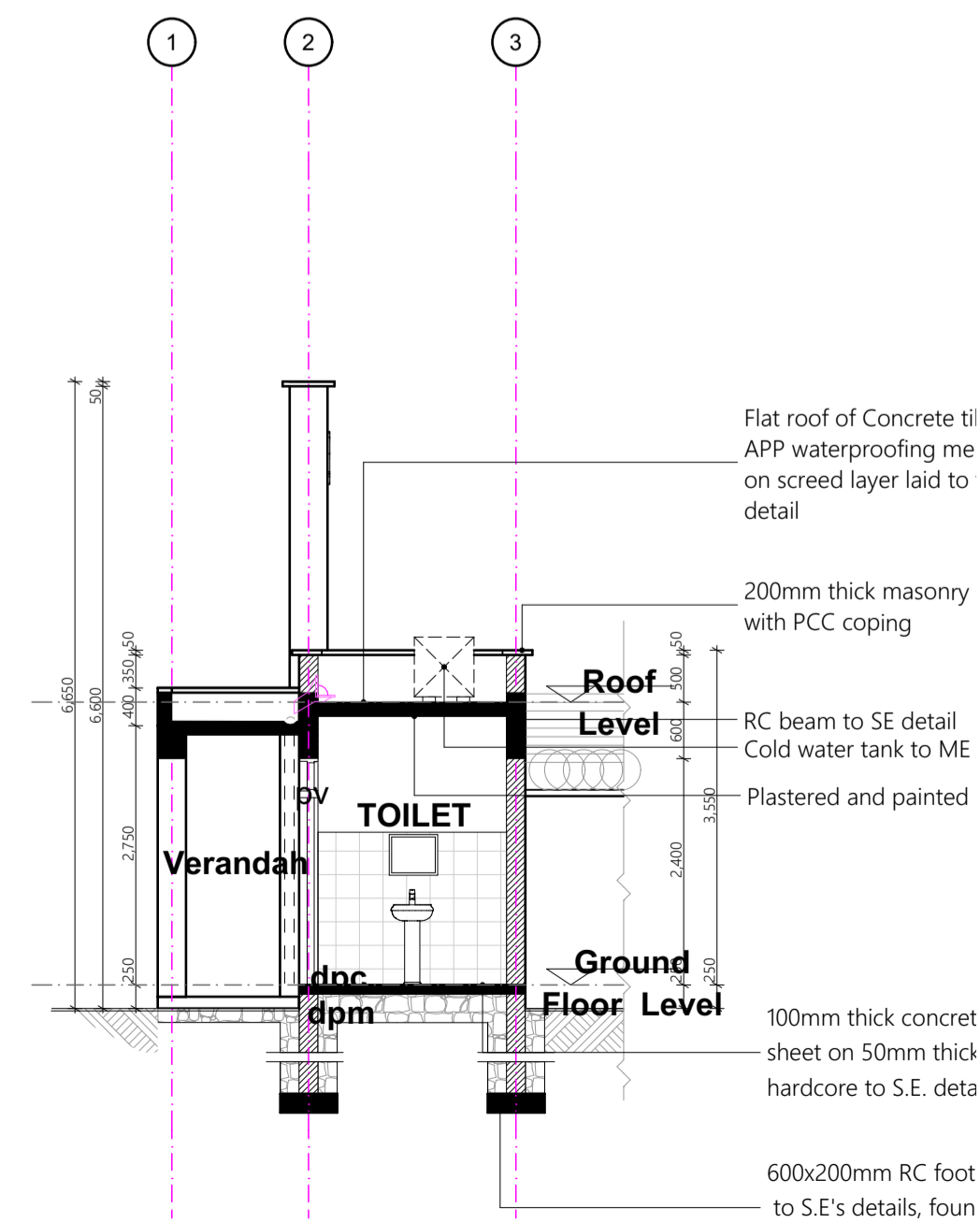

GENERAL NOTES

1. This drawing to be read in conjunction with Engineers' drawings.
2. All dimensions are in mm unless otherwise specified.
3. Drawings are not to be scaled. Only figured dimensions should be used.
4. The contractor must check and verify all dimensions before commencement of work and if necessary confirm with the architect.

CONSTRUCTION

Approved anti-termite treatment & 1000 gauge polythene sheeting cover to be provided under all ground floor concrete slab on compacted hardcore to approval.
DPC to be 3ply bituminous felt to be provided under all walls.

STRUCTURAL

1. All Black cotton soil to be removed from below all building and paved surfaces
2. All reinforced concrete work will be in accordance with structural drawings.
3. Foundation depths to be determined on site to S.E approval
4. All walls less than 200mm thick to be reinforced with hoop iron at every alternate course.
5. All adjacent R.C work and masonry walls to be tied with strap irons at every course

MECHANICAL

1. All Plumbing and Drainage Work to comply with specifications
2. S.V.P denotes soil vent pipe and to be provided at the head of the drainage
3. Where drainage is shown under driveways and slabs, to be encased in 150mm thick concrete surround.
4. All underground foul and waste drain pipes shall be of PVC to comply with BS5255
5. All ICs within building area, driveway and parking to have heavy duty, double-seal airtight covers and walls to be 200mm.
6. Minimum slope in the drain pipes to be 1%
7. No chases for pipes will be allowed in the slabs
8. Sleeves will be allowed with written approval from S.E.
9. No cutting of concrete without express approval of the Architect or S.E
10. All testing of pipes must be coordinated with electrical and any conflicts must be resolved before works begin
11. Permanent vents denoted as P.V to be provided as shown on plan.

ELECTRICAL

All conduits must be laid before plastering

PROJECT:

PROPOSED AFFORDABLE HOUSING DEVELOPMENT IN ALUPE UNIVERSITY

CLIENT:

Name: STATE DEPARTMENT FOR HOUSING AND URBAN DEVELOPMENT

Signature: _____ Date: _____

DRAWING TITLE:

GATE HOUSE DETAILS

SCALE:

1:20, 1:75

DRAWN BY:

CHECKED BY:

Name: _____

Signature: _____ Date: 13/03/2024

DATE:

MINISTRY OF LANDS , PUBLIC WORKS , HOUSING AND URBAN DEVELOPMENT
STATE DEPARTMENT FOR HOUSING & URBAN DEVELOPMENT



FOR THE GOVERNMENT OF THE
REPUBLIC OF KENYA

WASTE RECEIPTICLE

STUDENT HOUSING

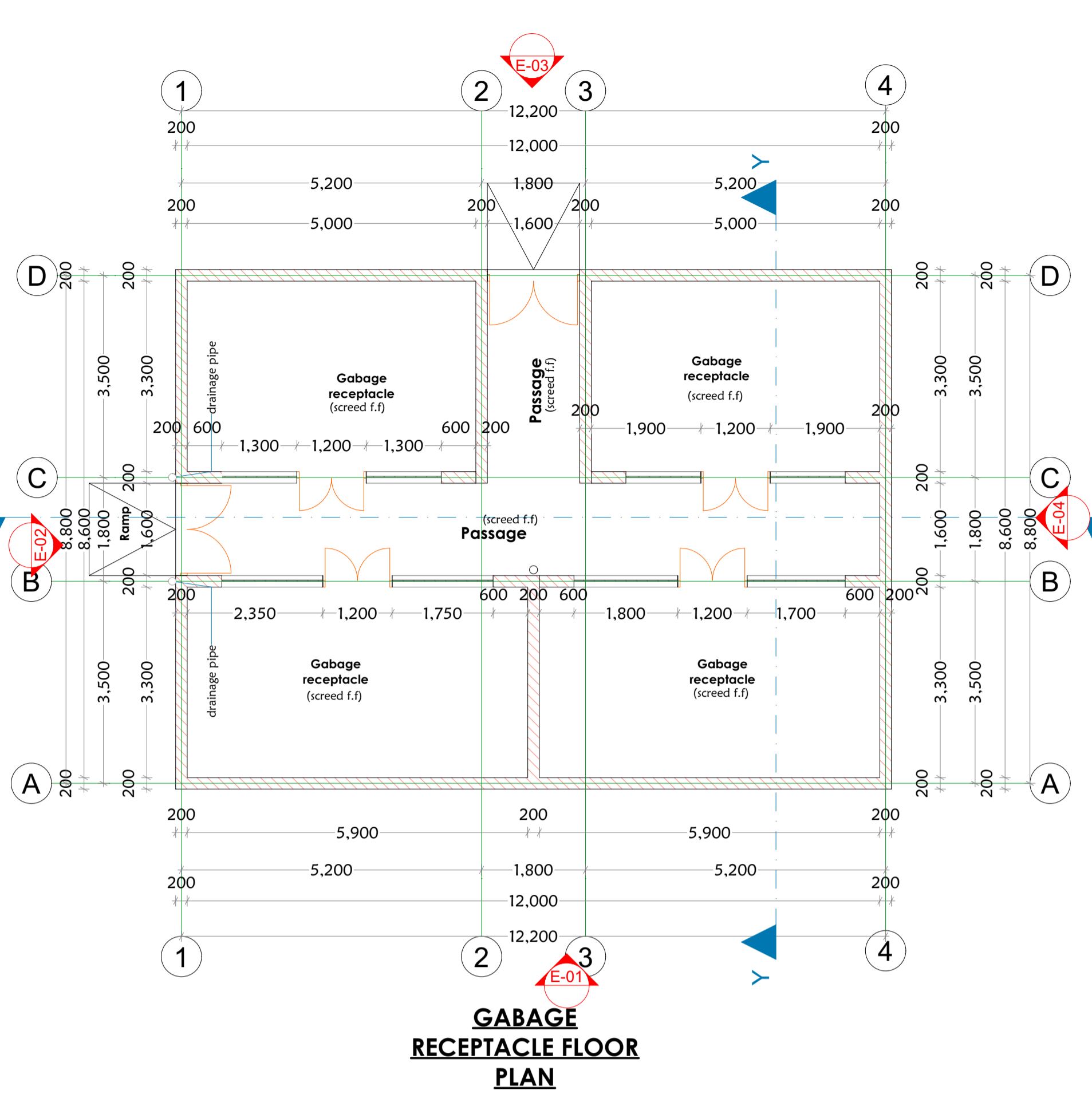

GABAGE RECEPTACLE FLOOR PLAN

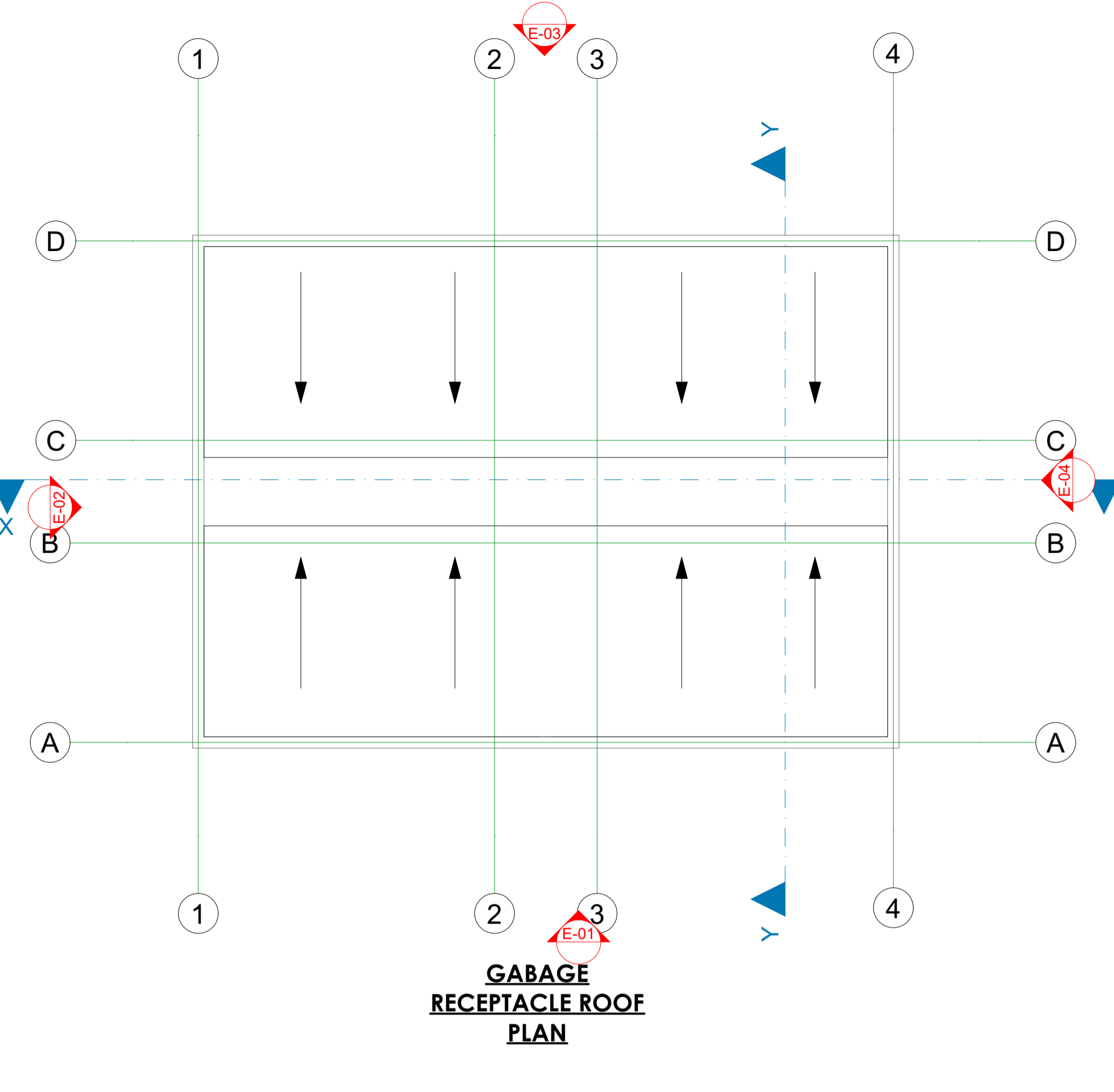

GABAGE RECEPTACLE ROOF PLAN

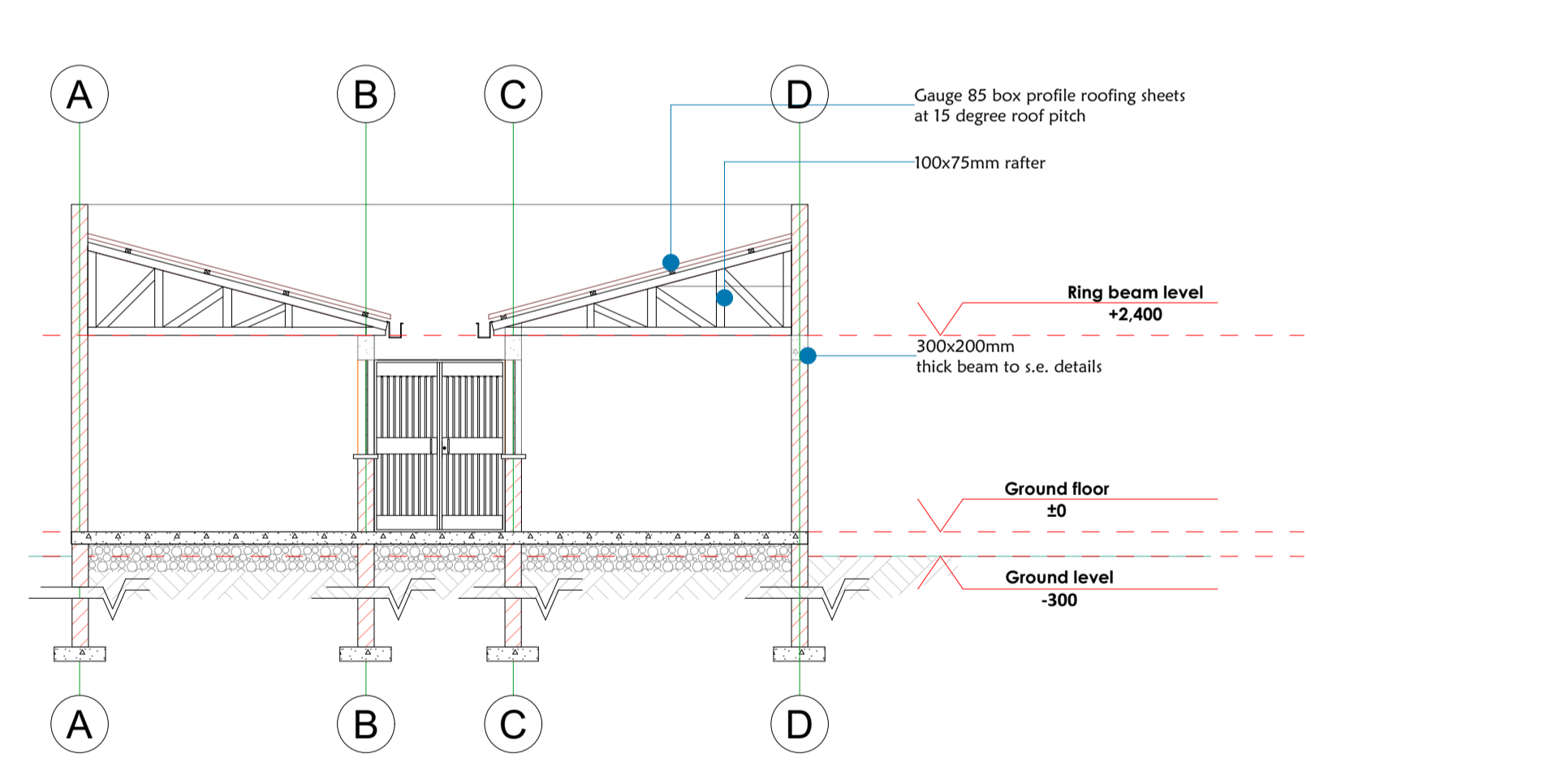

SECTION X-X

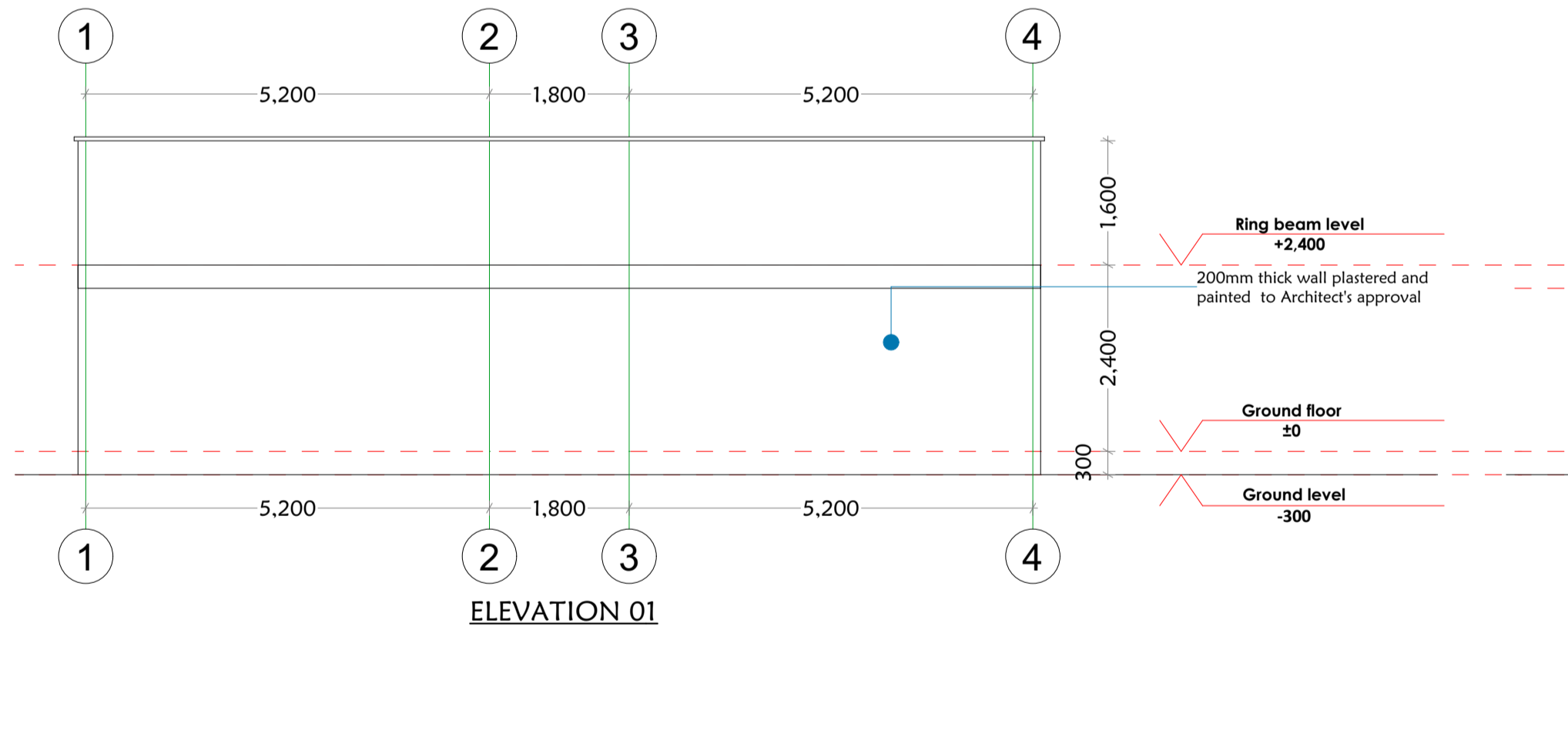

ELEVATION 01

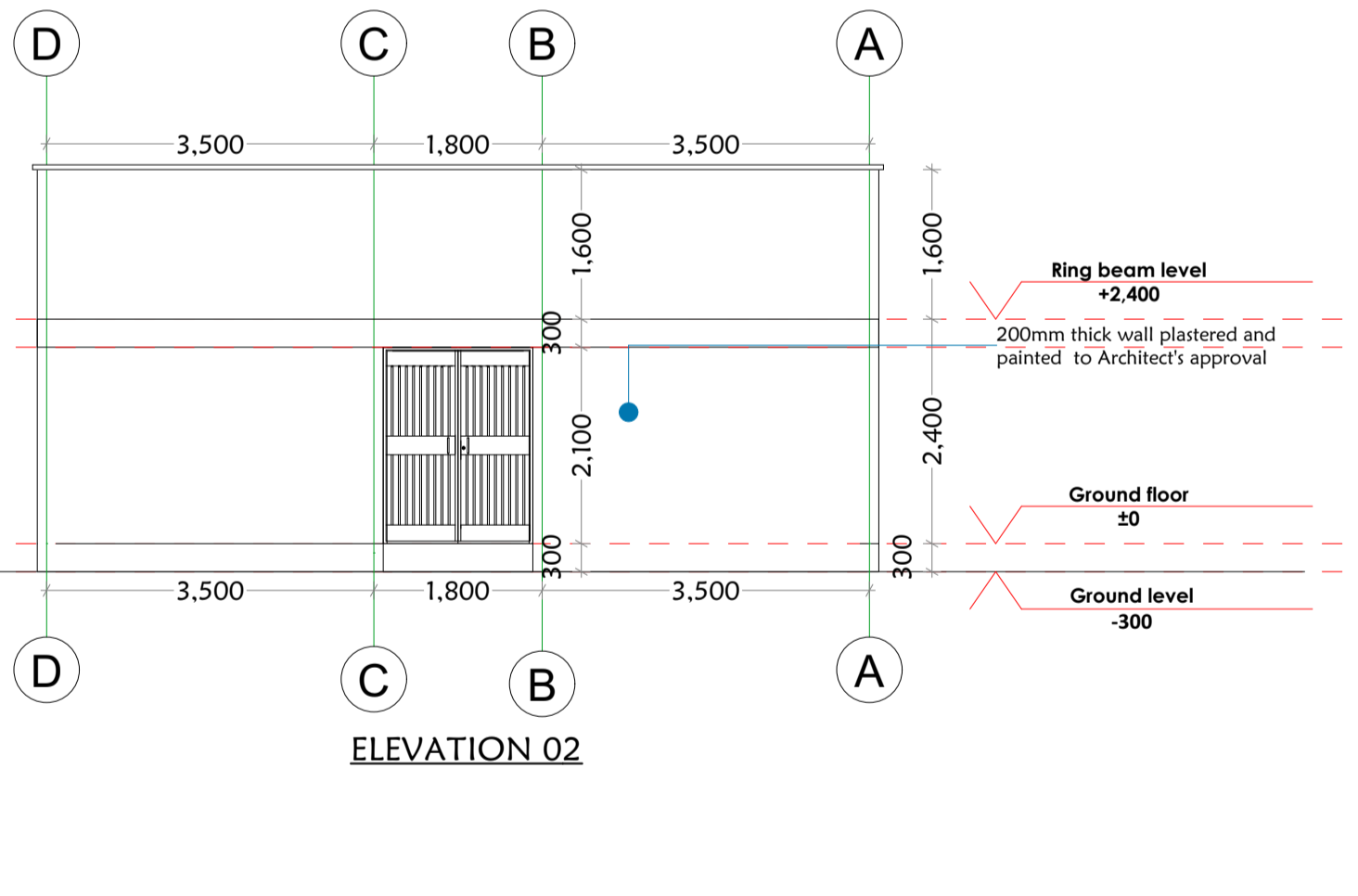

ELEVATION 02

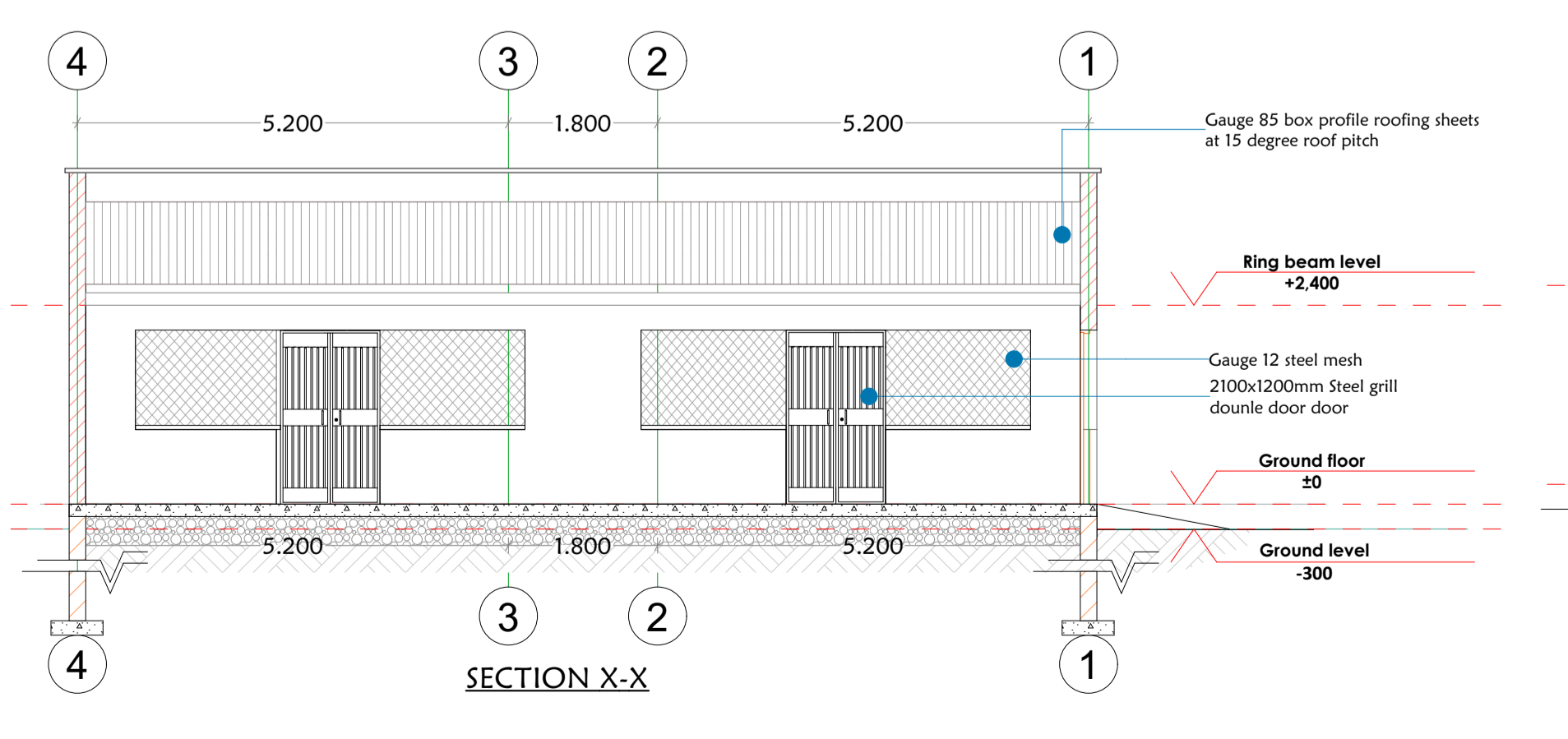

SECTION X-X

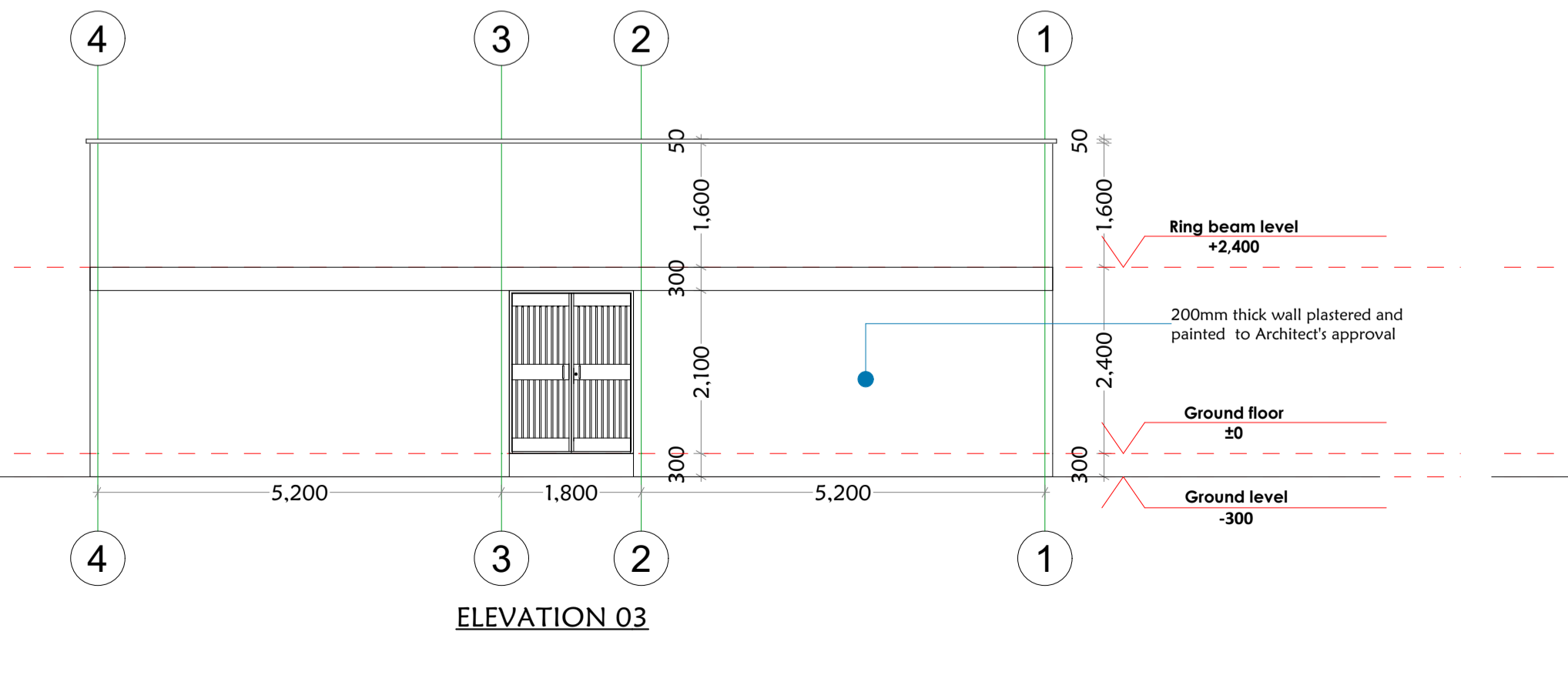

ELEVATION 03

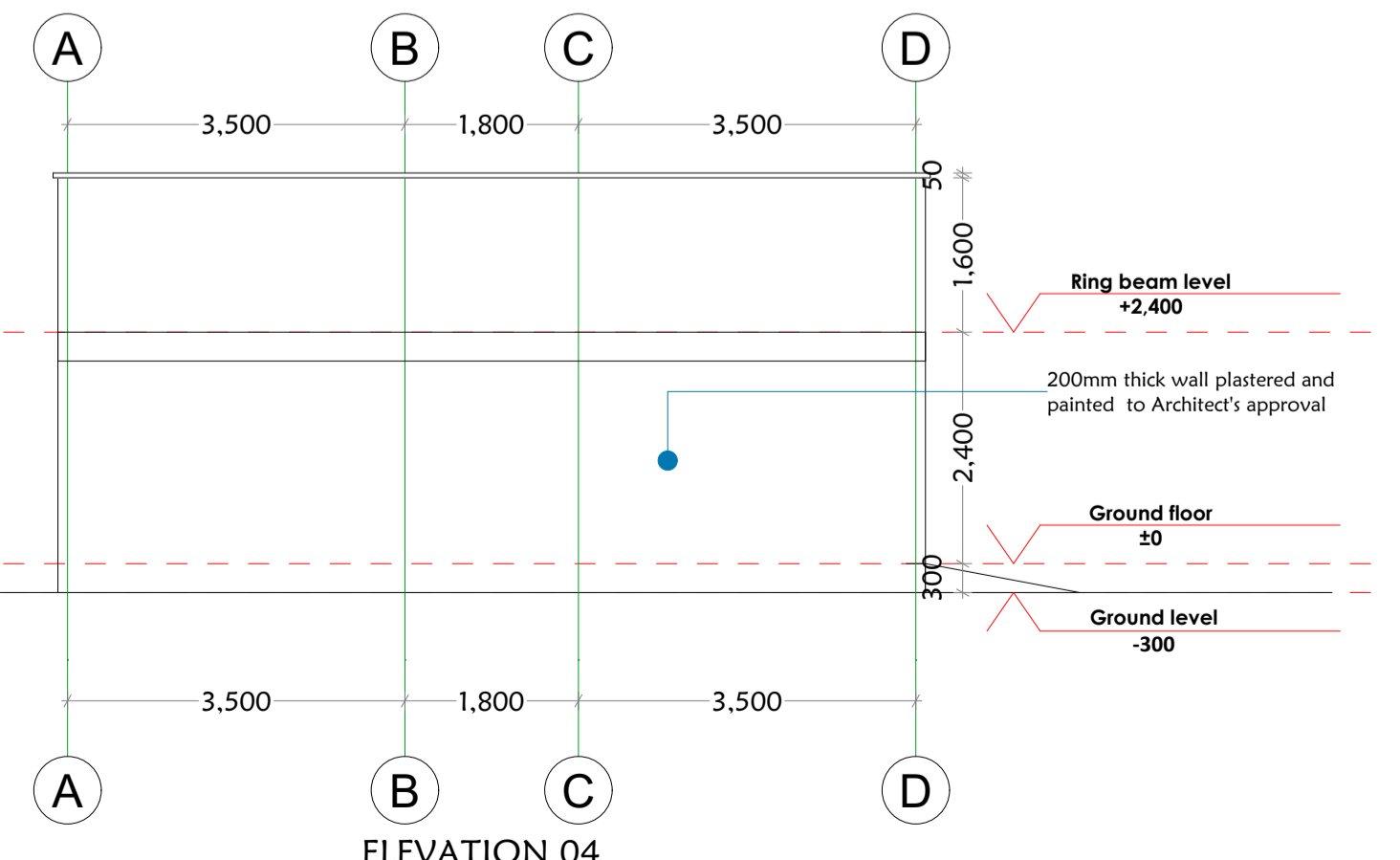

ELEVATION 04

DOOR SCHEDULE		
DOOR NO.	01	02
DOOR TYPE	SPRAY PAINTED STEEL CASEMENT EXTERIOR DOOR	SPRAY PAINTED STEEL CASEMENT EXTERIOR DOOR
DOOR NOS & LOCATION		
IRON MONGERY	-11/2 PAIRS OF HEAVY DUTY PIN TYPE HINGES -1 NO. RUBBER DOOR STOP -1 NO. 3 LEVER UNION LOCK -2 NO. 300 MM STAINLESS STEEL DOOR HANDLE	-11/2 PAIRS OF HEAVY DUTY PIN TYPE HINGES -1 NO. RUBBER DOOR STOP -1 NO. 3 LEVER UNION LOCK -2 NO. 300 MM STAINLESS STEEL DOOR HANDLE
FINISHES	ONE COAT PRIMER, TWO COATS GLOSS PAINT	ONE COAT PRIMER, TWO COATS GLOSS PAINT

GENERAL NOTES

1. This drawing to be read in conjunction with Engineers' drawings.
2. All dimensions are in mm unless otherwise specified.
3. Drawings are not to be scaled. Only figured dimensions should be used.
4. The contractor must check and verify all dimensions before commencement of work and if necessary confirm with the architect.

CONSTRUCTION

Approved anti-termite treatment & 1000 gauge polythene sheeting cover to be provided under all ground floor concrete slab on compacted hardcore to approval.
DPC to be 3ply bituminous felt to be provided under all walls.

STRUCTURAL

1. All Black coffin soil to be removed from below all building and paved surfaces
2. All reinforced concrete work will be in accordance with structural drawings.
3. Foundation depths to be determined on site to S.E approval
4. All walls less than 200mm thick to be reinforced with hoop iron at every alternate course.
5. All adjacent R.C work and masonry walls to be tied with strap irons at every course

MECHANICAL

1. All Plumbing and Drainage Work to comply with specifications
2. S.V.P denotes soil vent pipe and to be provided at the head of the drainage
3. Where drainage is shown under driveways and slabs, to be encased in 150mm thick concrete surround.
4. All underground foul and waste drain pipes shall be of PVC to comply with BS5255
5. All ICs within building area, driveway and parking to have heavy duty, double-seal airtight covers and walls to be 200mm.
6. Minimum slope in the drain pipes to be 1%
7. No chases for pipes will be allowed in the slabs
8. Sleeves will be allowed with written approval from S.E.
9. No cutting of concrete without express approval of the Architect or S.E
10. All testing of pipes must be coordinated with electrical and any conflicts must be resolved before works begin
11. Permanent vents denoted as P.V to be provided as shown on plan.

ELECTRICAL

All conduits must be laid before plastering

PROJECT:

PROPOSED AFFORDABLE HOUSING DEVELOPMENT IN ALUPE UNIVERSITY

CLIENT:

STATE DEPARTMENT FOR HOUSING AND URBAN DEVELOPMENT

Signature: _____ Date: _____

DRAWING TITLE:

FLOOR PLANS, SECT'S & ELEV'S

SCALE:

DRAWN BY: F.G.W.

CHECKED BY:

Name: _____

Signature: _____ Date: _____

DATE:

MINISTRY OF LANDS, PUBLIC WORKS, HOUSING AND URBAN DEVELOPMENT
STATE DEPARTMENT FOR HOUSING & URBAN DEVELOPMENT



FOR THE GOVERNMENT OF THE REPUBLIC OF KENYA

STRUCTURAL DRAWINGS

STUDENT HOUSING

GENERAL NOTES

1. This drawing to be read in conjunction with Engineers' drawings.
2. All dimensions are in mm unless otherwise specified.
3. Drawings are not to be scaled. Only figured dimensions should be used.
4. The contractor must check and verify all dimensions before commencement of work and if necessary confirm with the architect.

CONSTRUCTION

- Approved anti-termite treatment & 1000 gauge polythene sheeting to be provided under all ground floor concrete slabs on compacted hardcore to approval.
DPC to be 3-ply bituminous felt to be provided under all walls.

STRUCTURAL

1. All black cotton soil to be removed from below all building and paved surfaces.
2. All reinforced concrete work will be in accordance with structural drawings.
3. Foundation depth to be determined on site to S.E. approval.
4. All walls less than 200mm thick to be reinforced with hoop iron at every alternate course.
5. All adjacent R.C. work and masonry wall to be tied with strap iron at every course.

MECHANICAL

1. All Plumbing and Drainage Work to comply with specifications.
2. S.V. Denotes soil vent pipe and to be provided at the head of the drainage.
3. Where drainage is shown under driveways and slabs, to be cased in 150mm thick concrete surround.
4. All underground foul and waste drain pipes shall be of PVC to comply with BS 5255.
5. All C's within building area, driveway and parking to have heavy duty double-seal airtight covers and walls to be 200mm.
6. Minimum slope in drain pipes to be 1/1.
7. No chases for pipes will be allowed in the slabs.
8. Sleeves will be allowed with written approval from S.E.
9. No cutting of concrete without express approval of the Architect or S.E.
10. All testing of pipes must be coordinated with electrical and any conflicts must be resolved before work begins.
11. Permanent vents denoted as P.V. to be provided as shown on plan.

ELECTRICAL

All conduits must be laid before plastering.

PROJECT:

PROPOSED AFFORDABLE HOUSING DEVELOPMENT IN ALUPE UNIVERSITY

CLIENT:

Name: STATE DEPARTMENT FOR HOUSING AND URBAN DEVELOPMENT

Signature: _____ Date: _____

DRAWING TITLE:

TYPICAL BEAMS 3 OF 4

SCALE:

DRAWN BY:

CHECKED BY:

Name: _____

Signature: _____ Date: _____

DATE:

MINISTRY OF LANDS, PUBLIC WORKS, HOUSING AND URBAN DEVELOPMENT

STATE DEPARTMENT FOR HOUSING & URBAN DEVELOPMENT

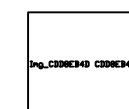

FOR THE GOVERNMENT OF THE REPUBLIC OF KENYA

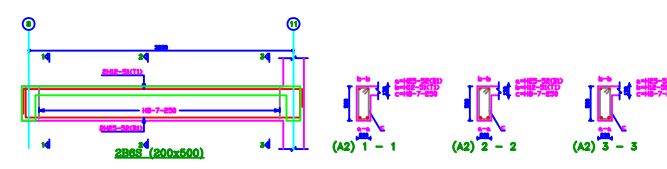
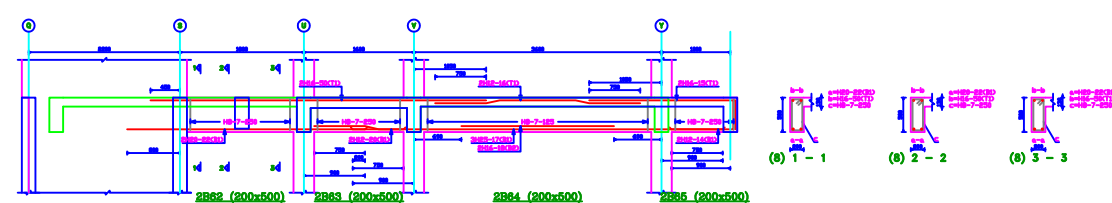
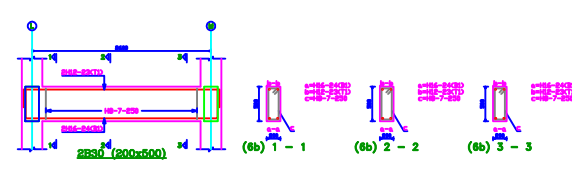
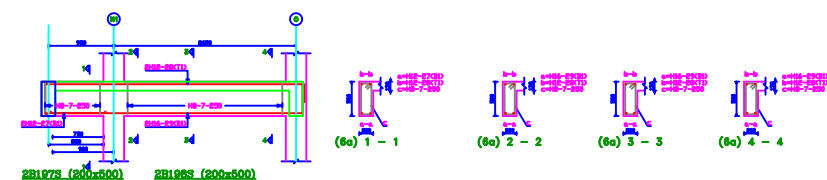
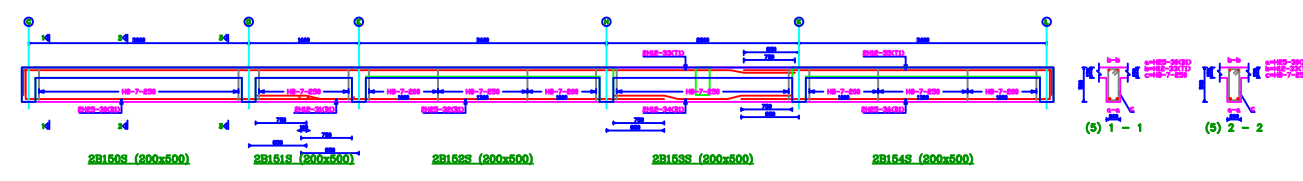
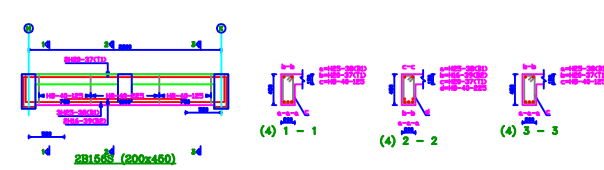
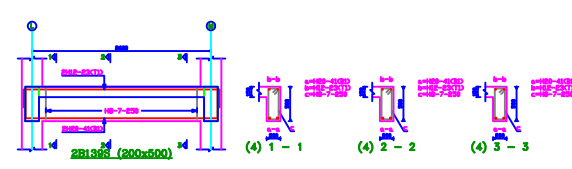
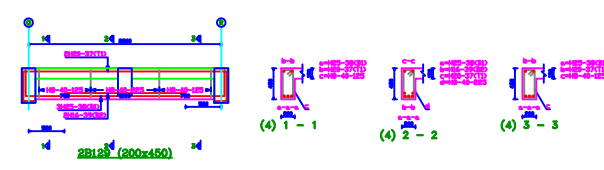
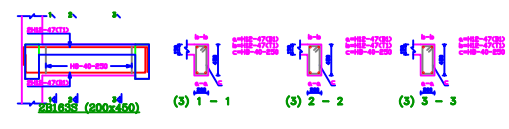
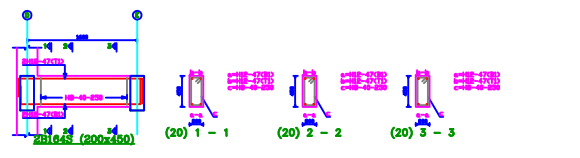
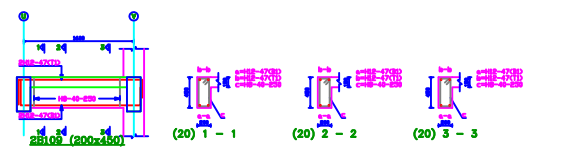
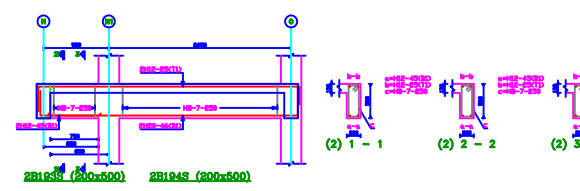
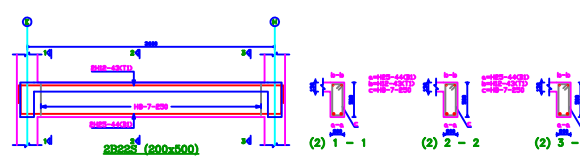
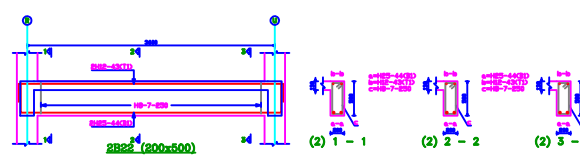
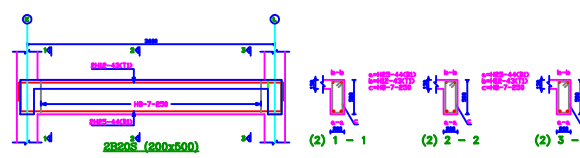
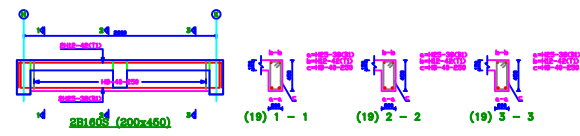
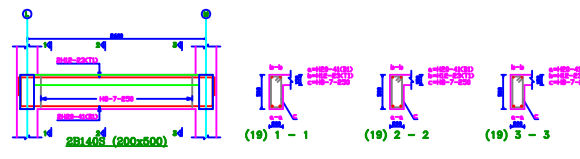
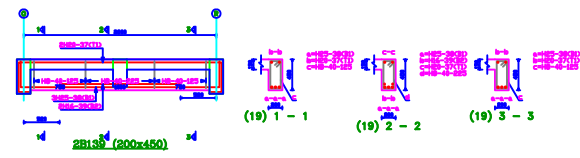

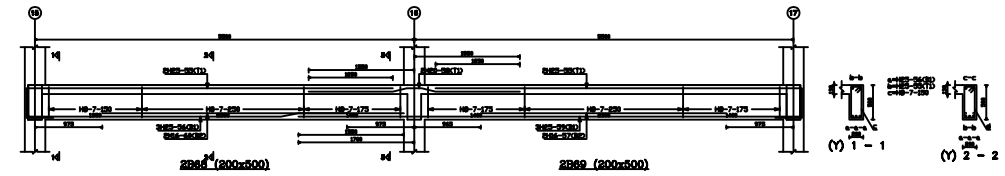
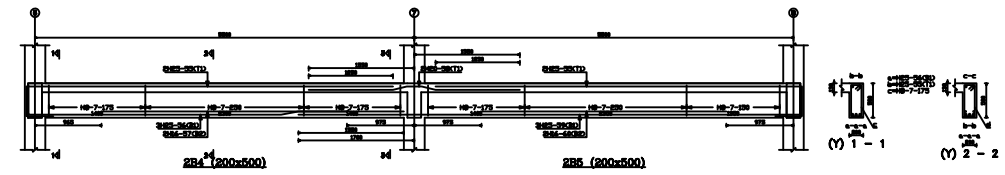
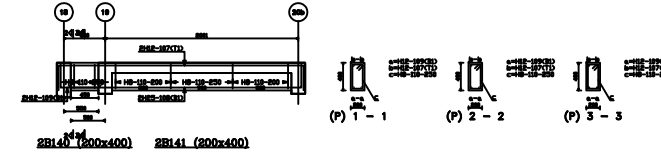
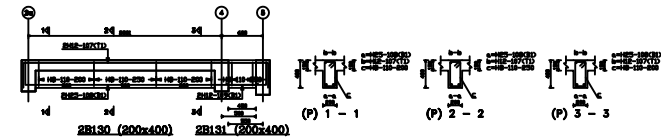
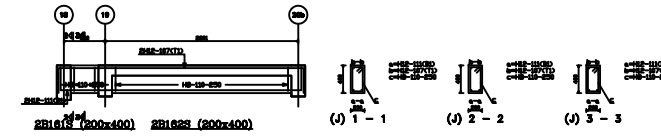
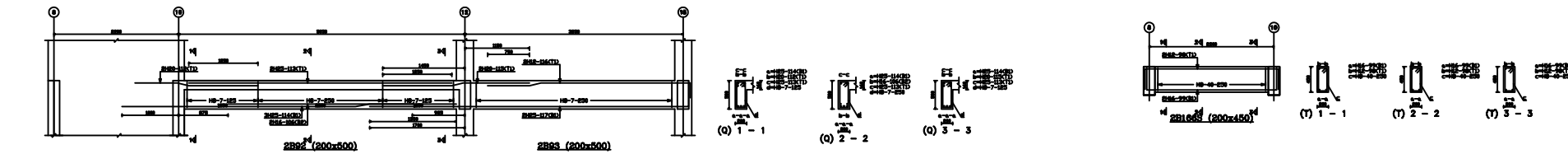
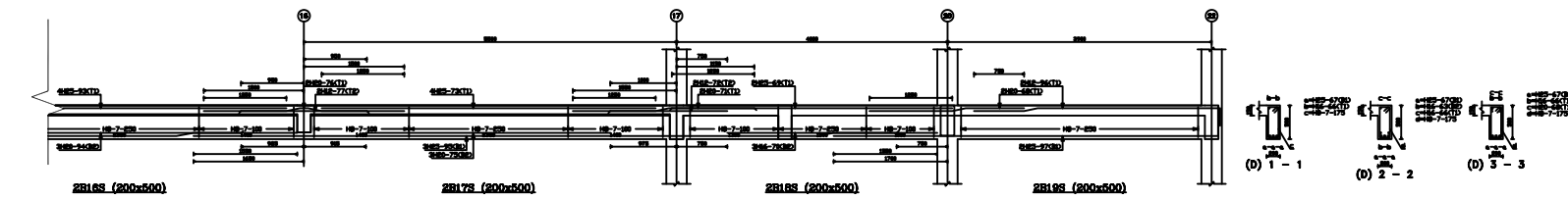
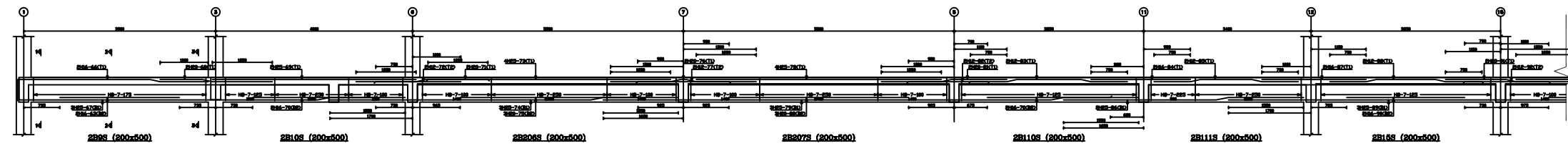
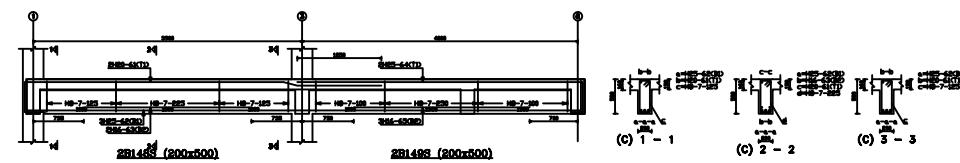
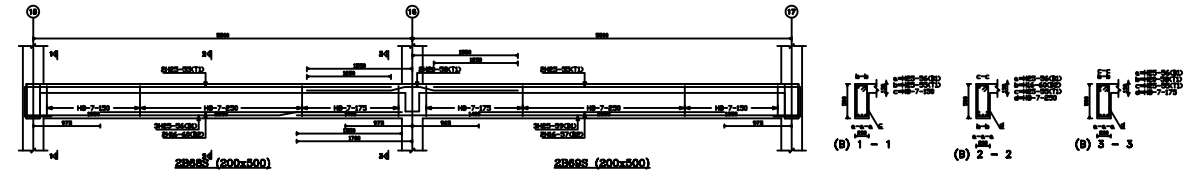
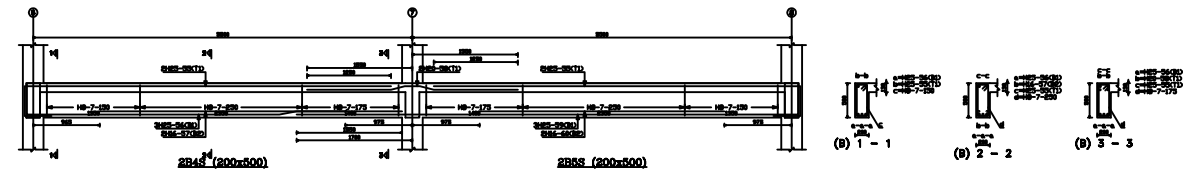
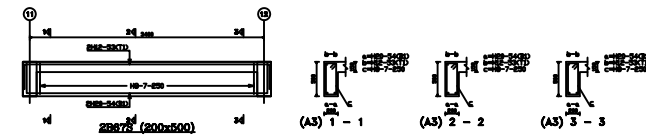
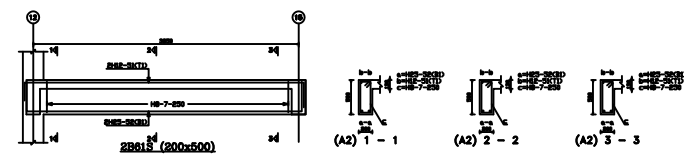

GENERAL NOTES

1. This drawing to be read in conjunction with Engineers' drawings.
2. All dimensions are in mm unless otherwise specified.
3. Drawings are not to be scaled. Only figured dimensions should be used.
4. The contractor must check and verify all dimensions before commencement of work and if necessary confirm with the architect.

CONSTRUCTION

Approved anti-termite treatment & 1000 gauge polythene sheeting cover to be provided under all ground floor concrete slabs on compacted hardcore to approval. DPC to be 3 ply bituminous felt to be provided under all walls.

STRUCTURAL

1. All Black cotton soil to be removed from below wall building and paved surfaces.
2. All reinforced concrete work will be in accordance with structural drawings.
3. Foundation depth to be determined on site to S.E. approval.
4. All walls less than 200mm thick to be reinforced with hoop iron at every alternate course.
5. All adjacent R.C. work and masonry wall to be tied with trap iron at every course.

MECHANICAL

1. All Plumbing and Drainage Work to comply with specifications.
2. S.V.P. notes on soil vent pipe to be provided at the head of the drain.
3. Where drainage is shown under driveways and slabs, to be encased in 150mm thick concrete surround.
4. All underground foul and waste drain pipes shall be of PVC to comply with BS 5255.
5. All C.S. within building area, driveway and parking to have heavy duty double seal airtight covers and walls to be 200mm.
6. Minimum slope in the drain pipe to be 1.
7. No chases for pipes will be allowed in the slabs.
8. Sleeves will be allowed with written approval from S.E.
9. No cutting of concrete without express approval of the Architect or S.E.
10. All testing of pipes must be coordinated with electrical and any conflicts must be resolved before work begins.
11. Permanent vents denoted as P.V. to be provided as shown on plan.

ELECTRICAL

All conduits must be laid before plastering.

PROJECT:

PROPOSED AFFORDABLE HOUSING DEVELOPMENT IN ALUPE UNIVERSITY

CLIENT:

Name: STATE DEPARTMENT FOR HOUSING AND URBAN DEVELOPMENT

Signature: _____ Date: _____

DRAWING TITLE:

TYPICAL BEAMS 2 OF 4

SCALE:

DRAWN BY:

CHECKED BY:

Name: _____

Signature: _____ Date: _____

DATE:

MINISTRY OF LANDS, PUBLIC WORKS, HOUSING AND URBAN DEVELOPMENT
STATE DEPARTMENT FOR HOUSING & URBAN DEVELOPMENT

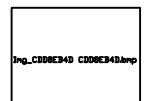

FOR THE GOVERNMENT OF THE REPUBLIC OF KENYA

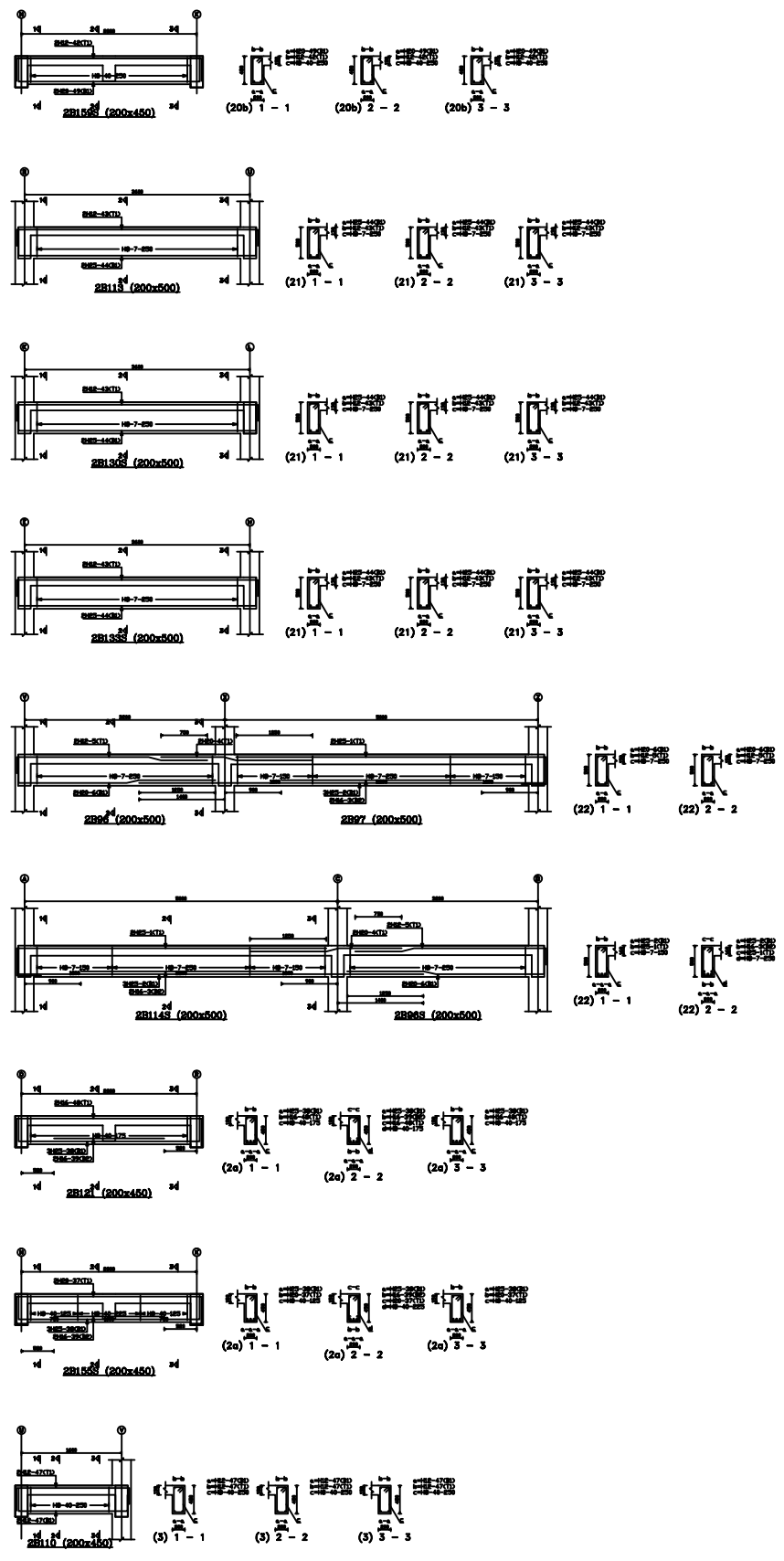
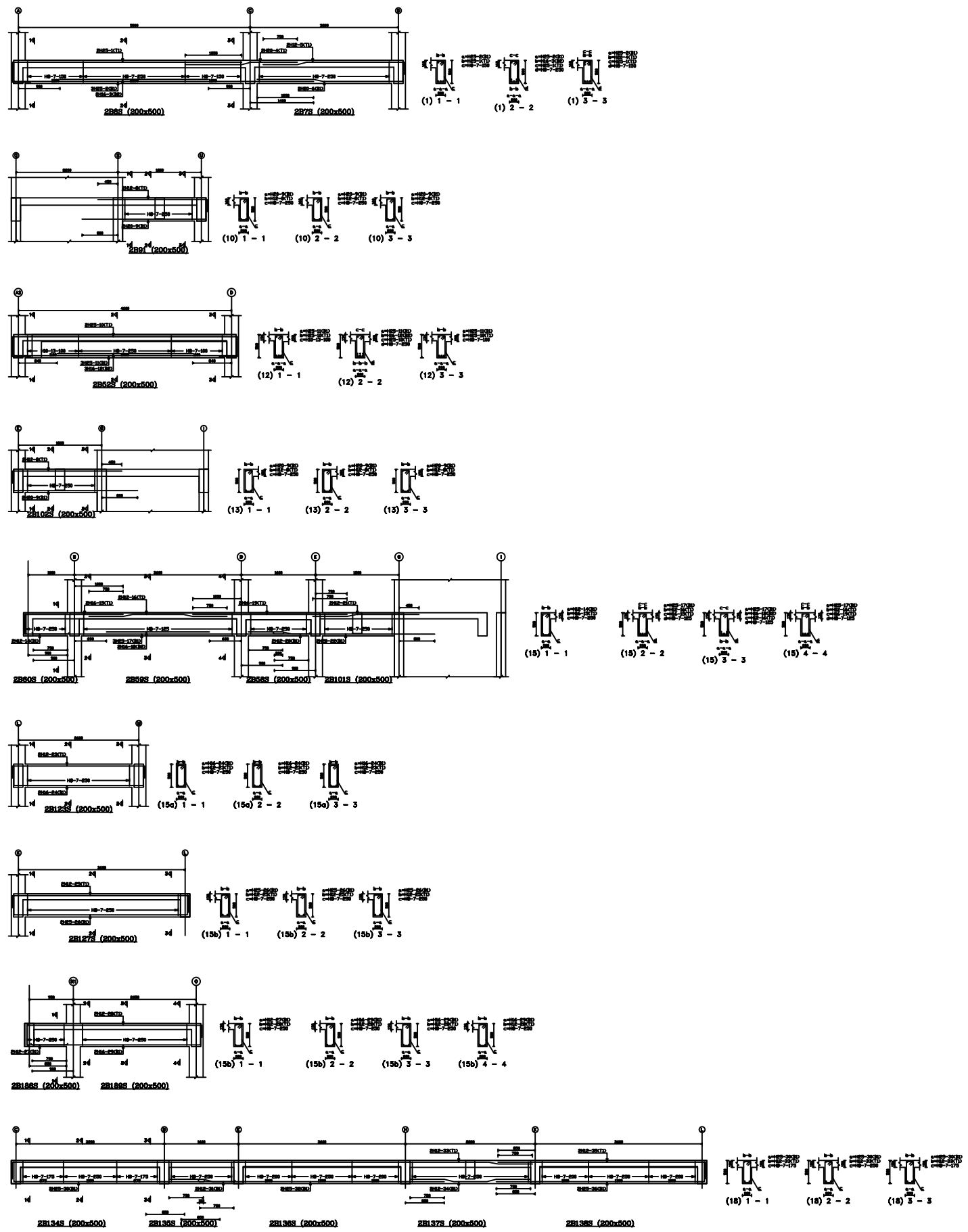

GENERAL NOTES

- This drawing to be read in conjunction with Engineers' drawings.
- All dimensions are in mm unless otherwise specified.
- Drawings are not to be scaled. Only figured dimensions should be used.
- The contractor must check and verify all dimensions before commencement of work and if necessary confirm with the architect.

CONSTRUCTION

Approved anti-termite treatment & 1000 gauge polythene sheeting cover to be provided under all ground floor concrete slabs on compacted hardcore to approval.

DPC to be 3 ply bituminous felt to be provided under all walls.

STRUCTURAL

- All black cotton soil to be removed from below all building and paved surfaces.
- All reinforced concrete work will be in accordance with structural drawings.
- Foundation depth to be determined on site to S.E. approval.
- All walls less than 200mm thick to be reinforced with hoop iron at every alternate course.
- All adjacent R.C. work and masonry wall to be tied with trap iron at every course.

MECHANICAL

- All Plumbing and Drainage Work to comply with specifications.
- S.V.P. denotessoilvent pipe and to be provided at the head of the drainage.
- Where drainage is shown under driveways and slabs, to be encased in 150mm thick concrete surround.
- All underground foul and waste drain pipes shall be of PVC to comply with BS 5255.
- All C's within building area, driveway and parking to have heavy duty double seal airtight covers and wall to be 200mm.
- Minimum slope in the drain pipe to be 1/100.
- No chases for pipes will be allowed in the slabs.
- Sleeves will be allowed with written approval from S.E.
- No cutting of concrete without express approval of the Architect or S.E.
- All testing of pipes must be coordinated with electrical and any conflicts must be resolved before works begin.
- Permanent vents denoted as P.V. to be provided as shown in plan.

ELECTRICAL

All conduits must be laid before plastering.

PROJECT:
 PROPOSED AFFORDABLE HOUSING DEVELOPMENT IN ALUPE UNIVERSITY

CLIENT:
 Name: STATE DEPARTMENT FOR HOUSING AND URBAN DEVELOPMENT
 Signature: _____ Date: _____

DRAWING TITLE:
 TYPICAL BEAMS 1 OF 4

SCALE:

DRAWN BY:

CHECKED BY:
 Name: _____
 Signature: _____ Date: _____

DATE:

MINISTRY OF LANDS, PUBLIC WORKS, HOUSING AND URBAN DEVELOPMENT
 STATE DEPARTMENT FOR HOUSING & URBAN DEVELOPMENT

FOR THE GOVERNMENT OF THE REPUBLIC OF KENYA

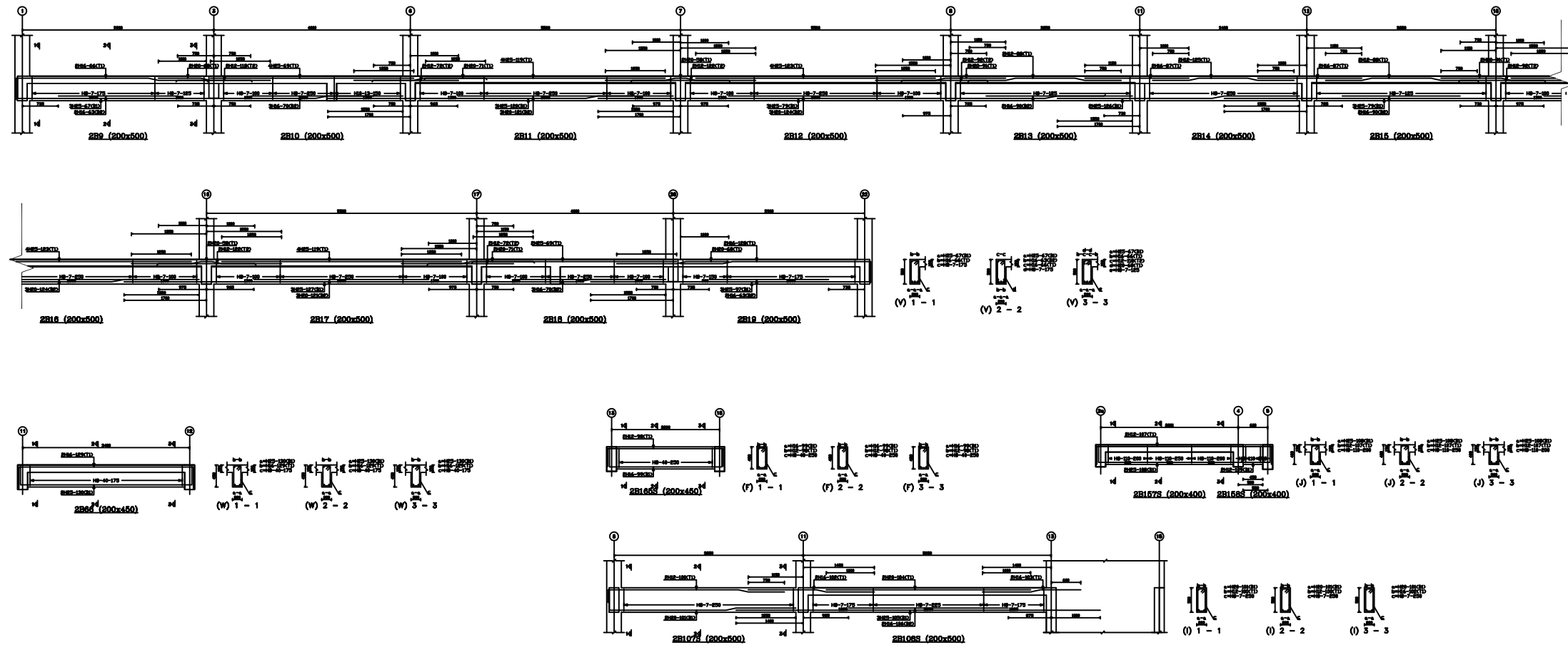

GENERAL NOTES

1. This drawing to be read in conjunction with Engineers' drawings.
2. All dimensions are in mm unless otherwise specified.
3. Drawings are not to be scaled. Only figured dimensions should be used.
4. The contractor must check and verify all dimensions before commencement of work and necessary confirm with the architect.

CONSTRUCTION

- Approved anti-termite treatment & 1000 gauge polythene sheeting cover to be provided under all ground floor concrete slabs on compacted hardcore to approval.
- DPCT to be 3-ply bituminous felt to be provided under all walls.

STRUCTURAL

1. All Black cotton soil to be removed from below wall building and paved surfaces.
2. All reinforced concrete work will be in accordance with structural drawings.
3. Foundation depths to be determined on site to S.E. approval.
4. All walls less than 200mm thick to be reinforced with hoop iron at every alternate course.
5. All adjacent R.C. work and masonry walls to be tied with strap iron at every course.

MECHANICAL

1. All Plumbing and Drainage Work to comply with specifications.
2. S.V. Pdenotessoilvent pipe and to be provided at the head of the drainage.
3. Where drainage is shown under driveways and slabs, to be encased in 150mm thick concrete surround.
4. All underground foul and waste drain pipes shall be of PVC to comply with BS 5255.
5. All I.C.s within building area, driveway and parking to have heavy duty, double-seal airtight covers and walls to be 200mm.
6. Minimum slope in the drain pipe to be 1/100.
7. No chases for pipes will be allowed in the slabs.
8. Sleeves will be allowed with written approval from S.E.
9. No cutting of concrete without express approval of the Architect or S.E.
10. All testing of pipes must be coordinated with electrical and any conflicts must be resolved before work begins.
11. Permanent vents denoted as P.V. to be provided as shown on plan.

ELECTRICAL

- All conduits must be laid before plastering.

PROJECT:

PROPOSED AFFORDABLE HOUSING DEVELOPMENT IN ALUPE UNIVERSITY

CLIENT:

STATE DEPARTMENT FOR HOUSING AND URBAN DEVELOPMENT

Signature: _____ Date: _____

DRAWING TITLE :

TYPICAL BEAMS 4 OF 4

SCALE:

DRAWN BY :

CHECKED BY :

Name: _____

Signature: _____ Date: _____

DATE:

MINISTRY OF LANDS, PUBLIC WORKS, HOUSING AND URBAN DEVELOPMENT
STATE DEPARTMENT FOR HOUSING & URBAN DEVELOPMENT



FOR THE GOVERNMENT OF THE REPUBLIC OF KENYA

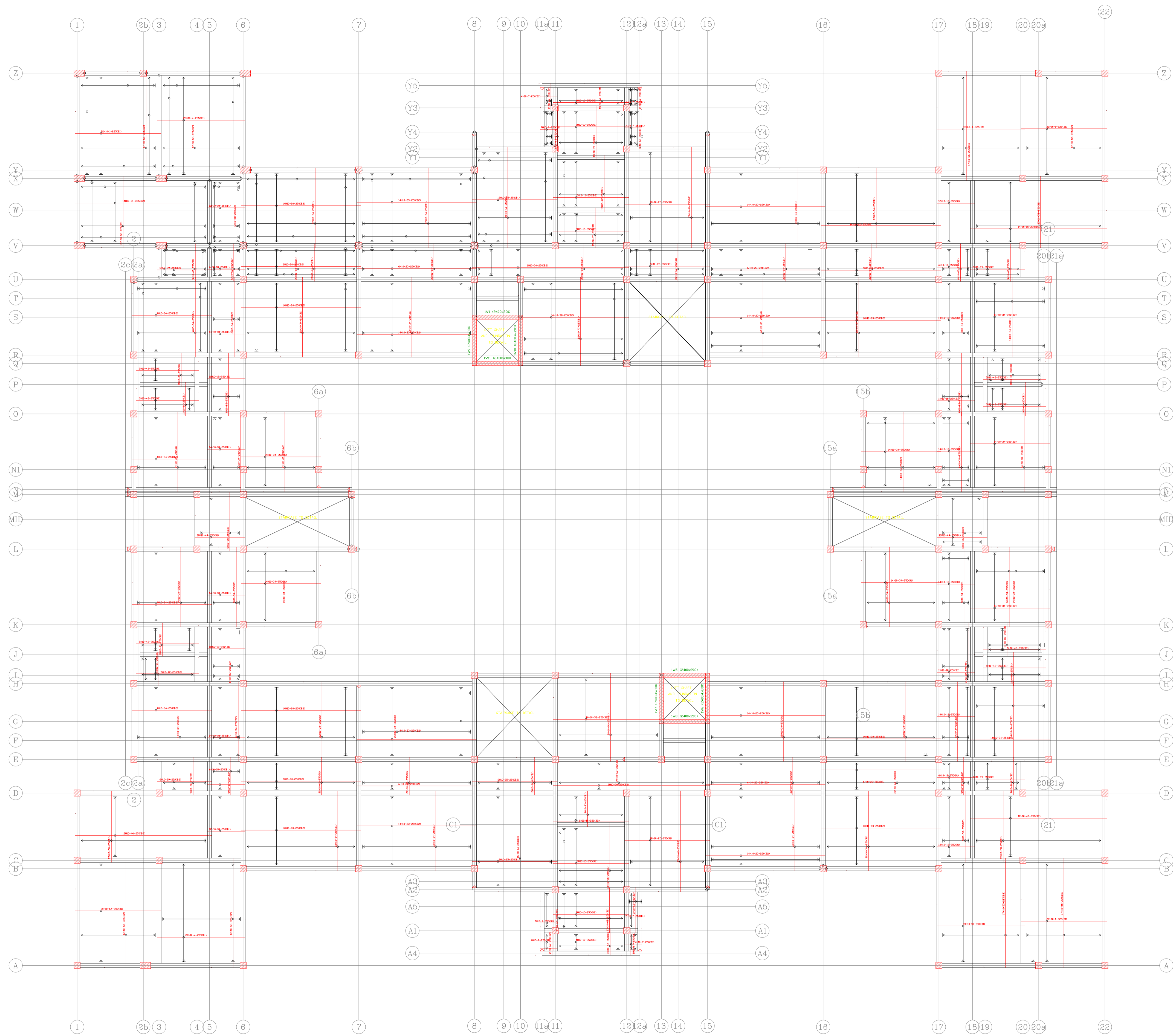

1ST FLOOR REINFORCEMENT
DETAILS

GENERAL NOTES

1. This drawing to be read in conjunction with Engineers' drawings.
2. All dimensions are in mm unless otherwise specified.
3. Drawings are not to be scaled. Only figured dimensions should be used.
4. The contractor must check and verify all dimensions before commencement of work and if necessary confirm with the architect.

CONSTRUCTION

Approved anti-termite treatment & 1000 gauge polythene sheeting cover to be provided under all ground floor concrete slab on compacted hardcore to approval.
DPC to be 3ply bituminous felt to be provided under all walls.

STRUCTURAL

1. All Black cotton soil to be removed from below all building and paved surfaces
2. All reinforced concrete work will be in accordance with structural drawings.
3. Foundation depths to be determined on site to S.E approval
4. All walls less than 200mm thick to be reinforced with hoop iron at every alternate course.
5. All adjacent R.C work and masonry walls to be tied with strap irons at every course

MECHANICAL

1. All Plumbing and Drainage Work to comply with specifications
2. S.V.P denotes soil vent pipe and to be provided at the head of the drainage
3. Where drainage is shown under driveways and slabs, to be encased in 150mm thick concrete surround.
4. All underground foul and waste drain pipes shall be of PVC to comply with BS 5255
5. All ICs within building area, driveway and parking to have heavy duty, double-seal airtight covers and walls to be 200mm.
6. Minimum slope in the drain pipes to be 1%
7. No chases for pipes will be allowed in the slabs
8. Sleeves will be allowed with written approval from S.E.
9. No cutting of concrete without express approval of the Architect or S.E
10. All testing of pipes must be coordinated with electrical and any conflicts must be resolved before works begin
11. Permanent vents denoted as P.V to be provided as shown on plan.

ELECTRICAL

All conduits must be laid before plastering

PROJECT:

PROPOSED AFFORDABLE HOUSING DEVELOPMENT IN ALUPE UNIVERSITY

CLIENT:

Name: STATE DEPARTMENT FOR HOUSING AND URBAN DEVELOPMENT

Signature: _____ Date: _____

DRAWING TITLE:

WORKING DRAWINGS

SCALE:

1:2500

DRAWN BY:

CHECKED BY:

Name: _____

Signature: _____ Date: _____

DATE:

MINISTRY OF LANDS, PUBLIC WORKS, HOUSING AND URBAN DEVELOPMENT

STATE DEPARTMENT FOR HOUSING & URBAN DEVELOPMENT

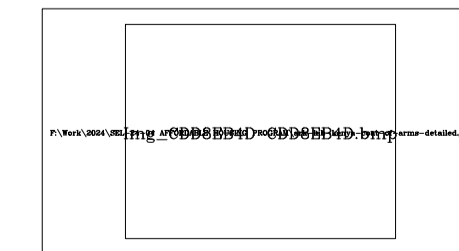

FOR THE GOVERNMENT OF THE
REPUBLIC OF KENYA

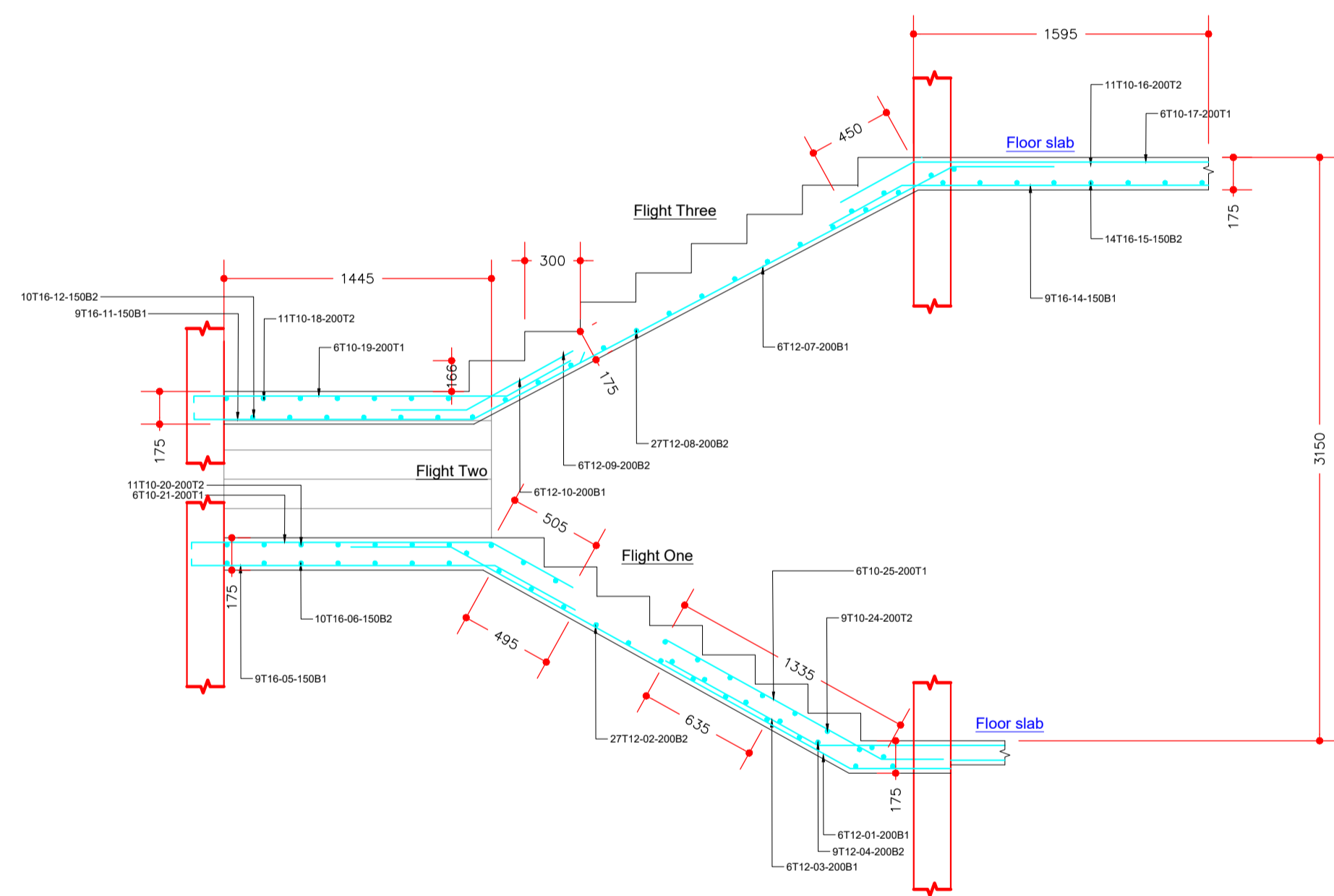
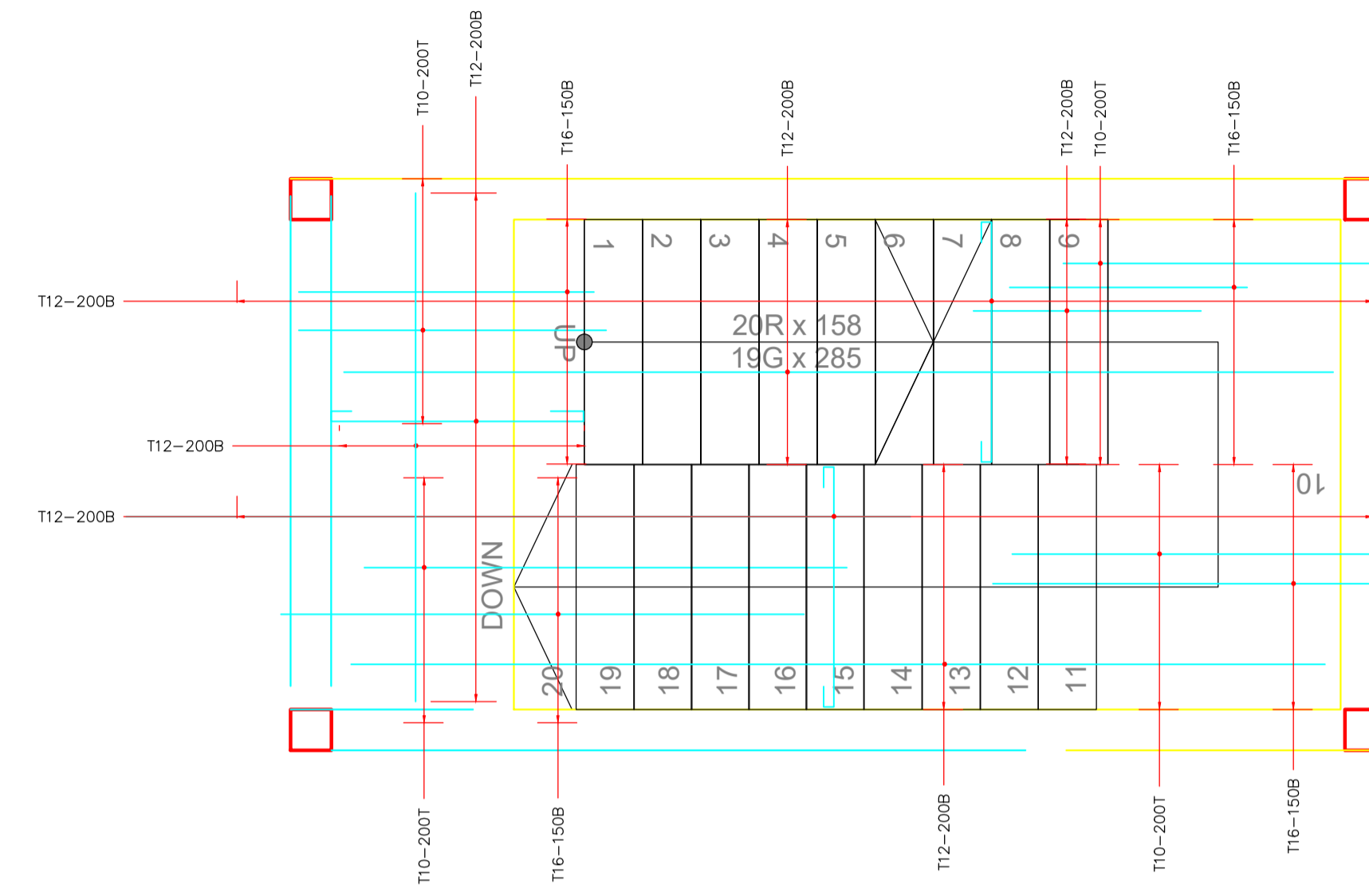
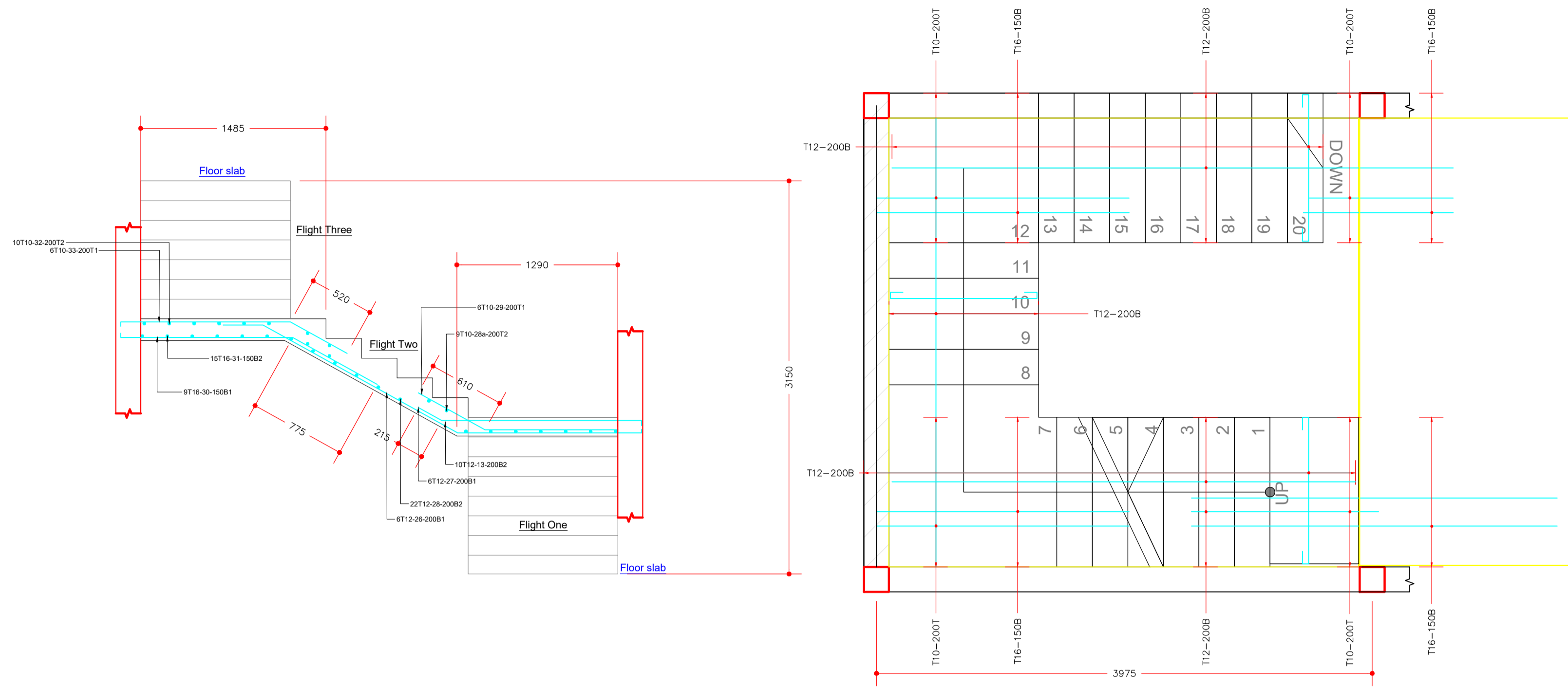

STAIRCASE TYPE 1 SECTION VIEW

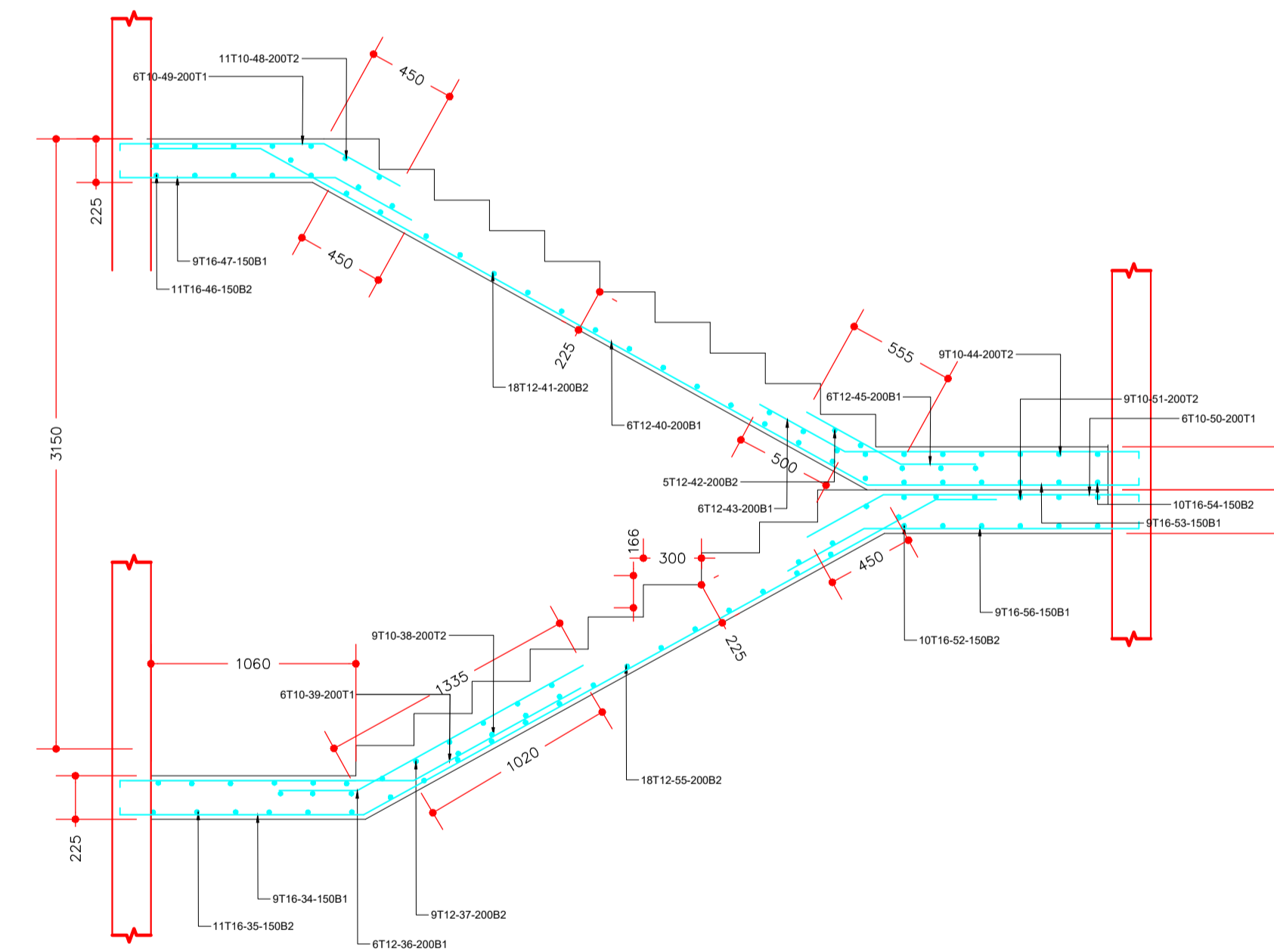

STAIRCASE TYPE 2 SECTION VIEW

GENERAL NOTES

1. This drawing to be read in conjunction with Engineers' drawings.
2. All dimensions are in mm unless otherwise specified.
3. Drawings are not to be scaled. Only figured dimensions should be used.
4. The contractor must check and verify all dimensions before commencement of work and if necessary confirm with the architect.

CONSTRUCTION

Approved anti-termite treatment & 1000 gauge polythene sheeting cover to be provided under all ground floor concrete slab on compacted hardcore to approval.
DPC to be 3ply bituminous felt to be provided under all walls.

STRUCTURAL

1. All Black cotton soil to be removed from below all building and paved surfaces
2. All reinforced concrete work will be in accordance with structural drawings.
3. Foundation depths to be determined on site to S.E approval
4. All walls less than 200mm thick to be reinforced with hoop iron at every alternate course.
5. All adjacent R.C work and masonry walls to be tied with strap irons at every course

MECHANICAL

1. All Plumbing and Drainage Work to comply with specifications
2. S.V.P denotes soil vent pipe and to be provided at the head of the drainage
3. Where drainage is shown under driveways and slabs, to be encased in 150mm thick concrete surround.
4. All underground foul and waste drain pipes shall be of PVC to comply with BS S255
5. All ICs within building area, driveway and parking to have heavy duty, double-seal airtight covers and walls to be 200mm.
6. Minimum slope in the drain pipes to be 1%
7. No chases for pipes will be allowed in the slabs
8. Sleeves will be allowed with written approval from S.E.
9. No cutting of concrete without express approval of the Architect or S.E
10. All testing of pipes must be coordinated with electrical and any conflicts must be resolved before works begin
11. Permanent vents denoted as P.V to be provided as shown on plan.

ELECTRICAL

All conduits must be laid before plastering

PROJECT:

PROPOSED AFFORDABLE HOUSING DEVELOPMENT IN ALUPE UNIVERSITY

CLIENT:

Name: STATE DEPARTMENT FOR HOUSING AND URBAN DEVELOPMENT

Signature: _____ Date: _____

DRAWING TITLE:

TYPICAL STAIRCASE DETAILS

SCALE:

1:1000

DRAWN BY:

Signature: _____ Date: _____

CHECKED BY:

Name: _____

Signature: _____ Date: _____

DATE:

MINISTRY OF LANDS, PUBLIC WORKS, HOUSING AND URBAN DEVELOPMENT

STATE DEPARTMENT FOR HOUSING & URBAN DEVELOPMENT

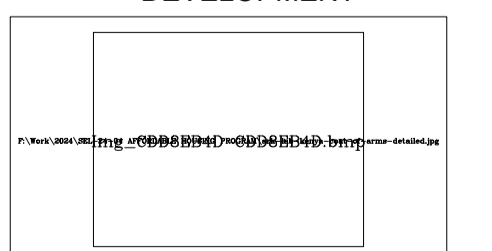

FOR THE GOVERNMENT OF THE REPUBLIC OF KENYA

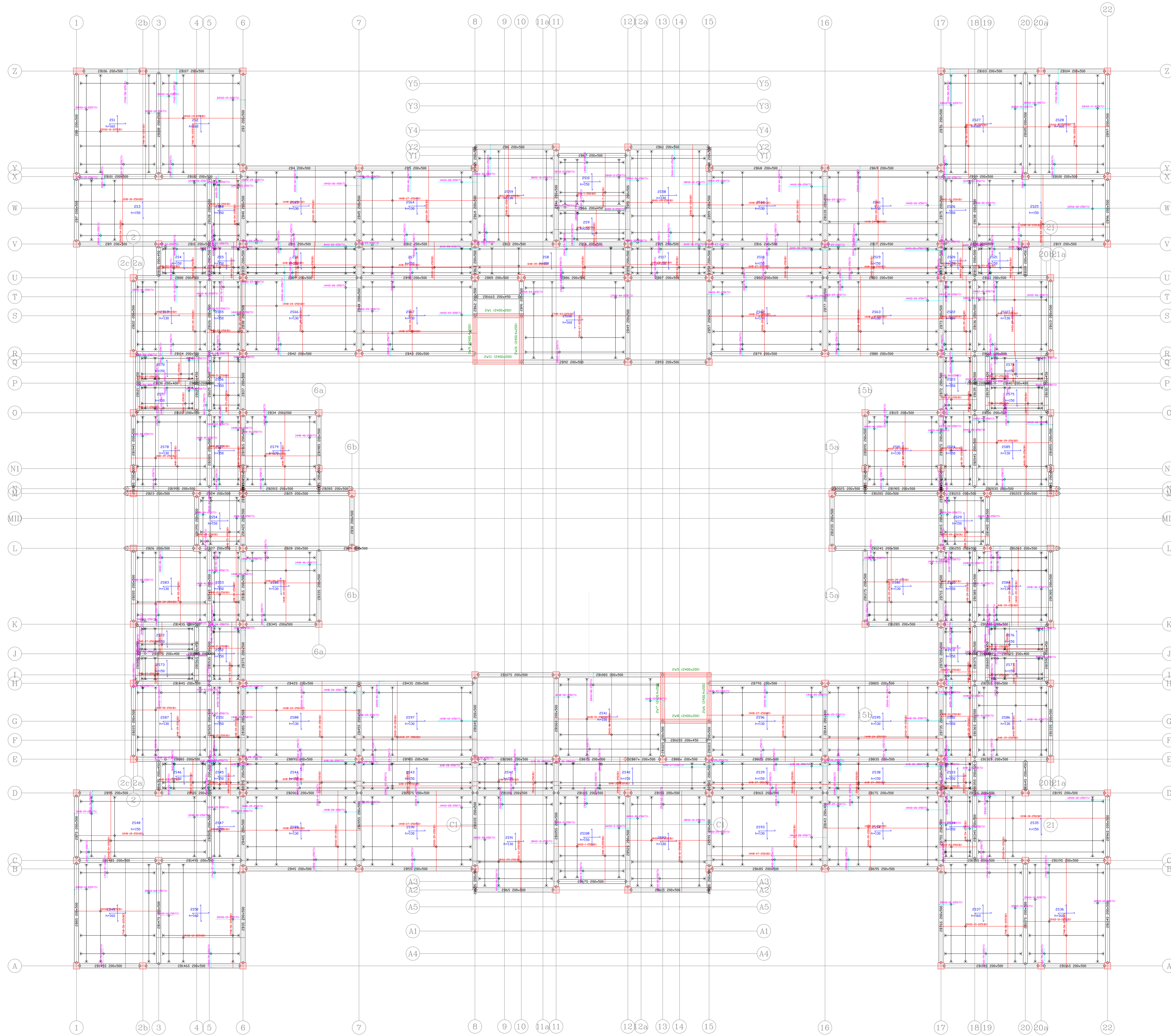

TYPICAL FLOOR REINFORCEMENT
DETAILS

GENERAL NOTES

1. This drawing to be read in conjunction with Engineers' drawings.
2. All dimensions are in mm unless otherwise specified.
3. Drawings are not to be scaled. Only figured dimensions should be used.
4. The contractor must check and verify all dimensions before commencement of work and if necessary confirm with the architect.

CONSTRUCTION

Approved anti-termite treatment & 1000 gauge polythene sheeting cover to be provided under all ground floor concrete slab on compacted hardcore to approval.
DPC to be 3ply bituminous felt to be provided under all walls.

STRUCTURAL

1. All Black cotton soil to be removed from below all building and paved surfaces
2. All reinforced concrete work will be in accordance with structural drawings.
3. Foundation depths to be determined on site to S.E approval
4. All walls less than 200mm thick to be reinforced with hoop iron at every alternate course.
5. All adjacent R.C work and masonry walls to be tied with strap irons at every course

MECHANICAL

1. All Plumbing and Drainage Work to comply with specifications
2. S.V.P denotes soil vent pipe and to be provided at the head of the drainage
3. Where drainage is shown under driveways and slabs, to be encased in 150mm thick concrete surround.
4. All underground foul and waste drain pipes shall be of PVC to comply with BS S255
5. All ICs within building area, driveway and parking to have heavy duty, double-seal airtight covers and walls to be 200mm.
6. Minimum slope in the drain pipes to be 1%
7. No chases for pipes will be allowed in the slabs
8. Sleeves will be allowed with written approval from S.E.
9. No cutting of concrete without express approval of the Architect or S.E
10. All testing of pipes must be coordinated with electrical and any conflicts must be resolved before works begin
11. Permanent vents denoted as P.V to be provided as shown on plan.

ELECTRICAL

All conduits must be laid before plastering

PROJECT:

PROPOSED AFFORDABLE HOUSING
DEVELOPMENT IN ALUPE UNIVERSITY

CLIENT:

Name: STATE DEPARTMENT FOR HOUSING AND
URBAN DEVELOPMENT

Signature: _____ Date: _____

DRAWING TITLE:

TYPICAL FLOOR REINFORCEMENT LAYOUT

SCALE:

1:2500

DRAWN BY:

CHECKED BY:

Name: _____

Signature: _____ Date: _____

DATE:

MINISTRY OF LANDS, PUBLIC WORKS,
HOUSING AND URBAN DEVELOPMENT

STATE DEPARTMENT FOR HOUSING & URBAN
DEVELOPMENT

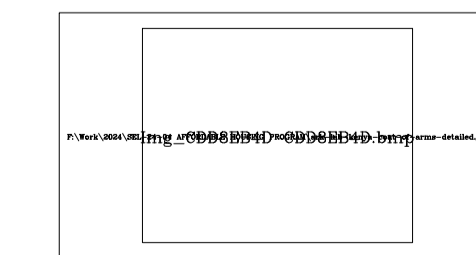

FOR THE GOVERNMENT OF THE
REPUBLIC OF KENYA

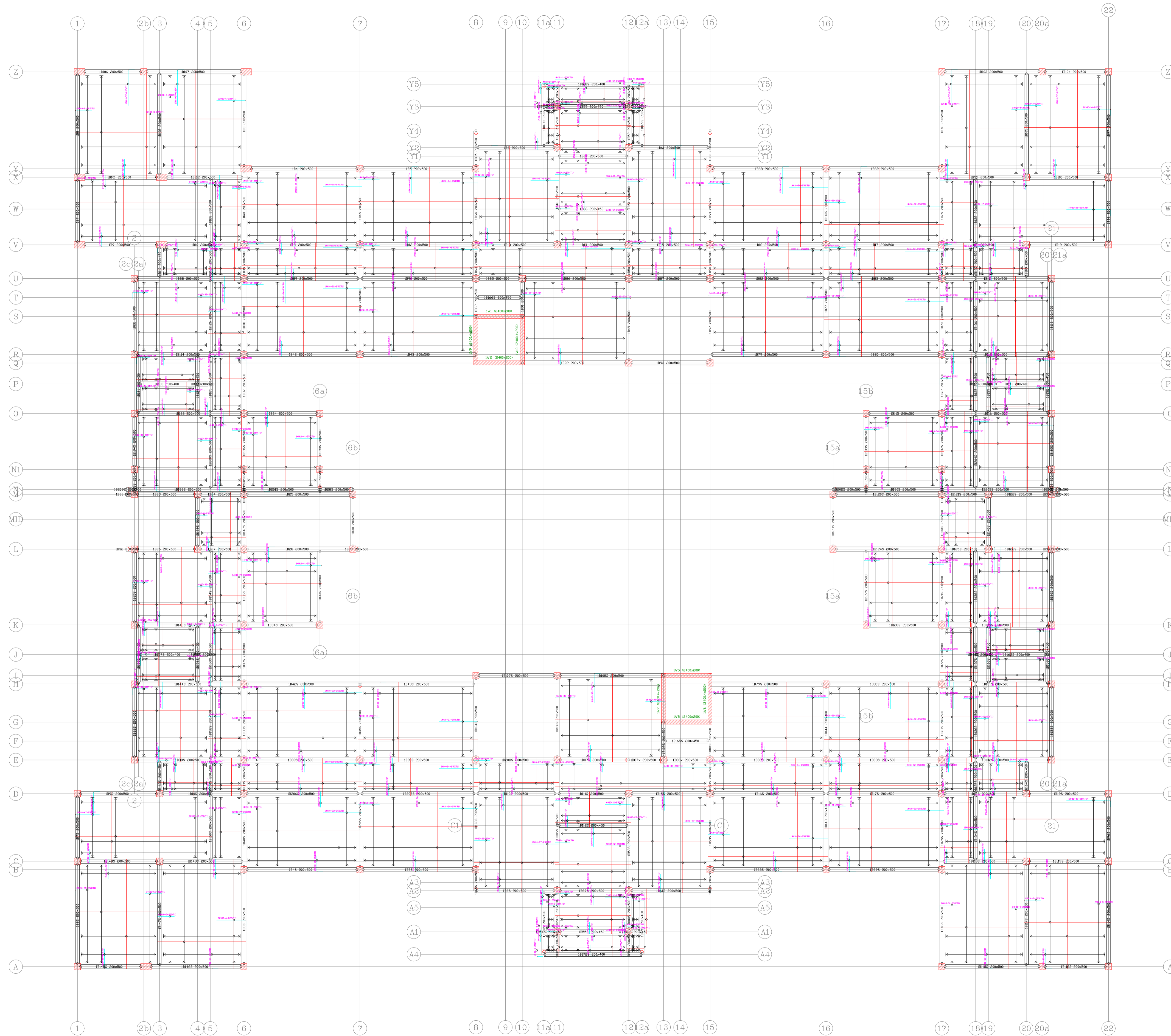

GENERAL NOTES

1. This drawing to be read in conjunction with Engineers' drawings.
2. All dimensions are in mm unless otherwise specified.
3. Drawings are not to be scaled. Only figured dimensions should be used.
4. The contractor must check and verify all dimensions before commencement of work and if necessary confirm with the architect.

CONSTRUCTION

Approved anti-termite treatment & 1000 gauge polythene sheeting cover to be provided under all ground floor concrete slab on compacted hardcore to approval.
DPC to be 3ply bituminous felt to be provided under all walls.

STRUCTURAL

1. All Black cotton soil to be removed from below all building and paved surfaces
2. All reinforced concrete work will be in accordance with structural drawings.
3. Foundation depths to be determined on site to S.E approval
4. All walls less than 200mm thick to be reinforced with hoop iron at every alternate course.
5. All adjacent R.C work and masonry walls to be tied with strap irons at every course

MECHANICAL

1. All Plumbing and Drainage Work to comply with specifications
2. S.V.P denotes soil vent pipe and to be provided at the head of the drainage
3. Where drainage is shown under driveways and slabs, to be encased in 150mm thick concrete surround.
4. All underground foul and waste drain pipes shall be of PVC to comply with BS S255
5. All ICs within building area, driveway and parking to have heavy duty, double-seal airtight covers and walls to be 200mm.
6. Minimum slope in the drain pipes to be 1%
7. No chases for pipes will be allowed in the slabs
8. Sleeves will be allowed with written approval from S.E.
9. No cutting of concrete without express approval of the Architect or S.E
10. All testing of pipes must be coordinated with electrical and any conflicts must be resolved before works begin
11. Permanent vents denoted as P.V to be provided as shown on plan.

ELECTRICAL

All conduits must be laid before plastering

PROJECT:

PROPOSED AFFORDABLE HOUSING DEVELOPMENT IN ALUPE UNIVERSITY

CLIENT:

Name: STATE DEPARTMENT FOR HOUSING AND URBAN DEVELOPMENT

Signature: _____ Date: _____

DRAWING TITLE:

WORKING DRAWINGS

SCALE:

1:2500

DRAWN BY:

CHECKED BY:

Name: _____

Signature: _____ Date: _____

DATE:

MINISTRY OF LANDS, PUBLIC WORKS, HOUSING AND URBAN DEVELOPMENT

STATE DEPARTMENT FOR HOUSING & URBAN DEVELOPMENT

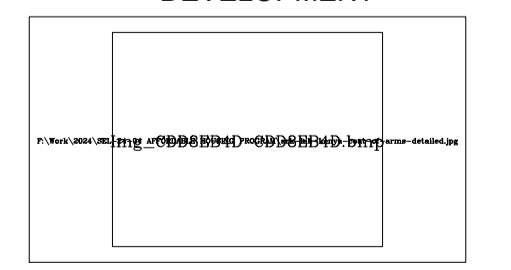





FOR THE GOVERNMENT OF THE REPUBLIC OF KENYA

ELECTRICAL DRAWINGS

STUDENT HOUSING

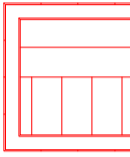
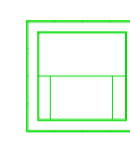
Notes:

1. THIS DRAWING IS TO BE READ WITH ALL OTHER DISCIPLINES, DRAWINGS, SCHEDULES AND SPECIFICATIONS, LEGEND AND STANDARD DETAILS.
2. THIS DRAWING IS A COPYRIGHT AND SHALL NOT BE REPRODUCED WITHOUT PERMISSION.
3. DIMENSIONS GOVERN ON ALL DRAWINGS AND DETAILS. SHOULD ANY DISCREPANCIES BE FOUND WITH THIS DRAWING AND ANY ASSOCIATED DRAWINGS, OR SPECIFICATIONS THIS SHOULD BE BROUGHT TO THE ATTENTION OF M&E BUILDING SERVICES CONSULTANT IMMEDIATELY. UNLESS OTHERWISE STATED ALL DIMENSIONS ARE IN MILLIMETERS. DO NOT SCALE FROM THIS DRAWING.
4. DIMENSIONS TO BE CHECKED ON SITE BEFORE ANY WORKS IS PUT IN HAND OR PREFABRICATED.
5. THIS DRAWING SHOULD BE USED FOR THE SPECIFIC SERVICES INTENDED. THIS DRAWING SHOWS THE DESIGN INTEND ONLY. THE CONTRACTOR SHALL BE RESPONSIBLE FOR FULL CO-ORDINATION OF THE SERVICES INDICATED ON THIS AND ALL OTHER SERVICES DRAWINGS.
6. FINAL ACCESS AND SETTING OUT OF SERVICES SHALL BE AGREED BETWEEN THE ARCHITECT AND THE CONTRACTOR.
7. THE PROJECT NOTES ARE TO BE READ IN CONJUNCTION WITH ALL RELEVANT TECHNICAL SPECIFICATIONS.

SYMBOL	DESCRIPTION
	POWER MANHOLE
	ICT MANHOLE
	POWER DISTRIBUTION BOARD
	ADAPTABLE BOX
	POWER DUCTS
	ICT DUCTS

REV	CHANGES	BY:	DATE:

CLIENT:
 STATE DEPARTMENT FOR HOUSING AND URBAN DEVELOPMENT

ARCHITECT:
 STRUCTURAL:
 QUANTITY SURVEYOR:

SITE:
 ALUPE STUDENT HOUSING

TITLE:
 ELECTRICAL SITE PLAN

SCALE: NOT TO SCALE	DATE:	DRAWN:	CHECKED:
PROJECT NO:	DRAWING NO:	REVISION:	

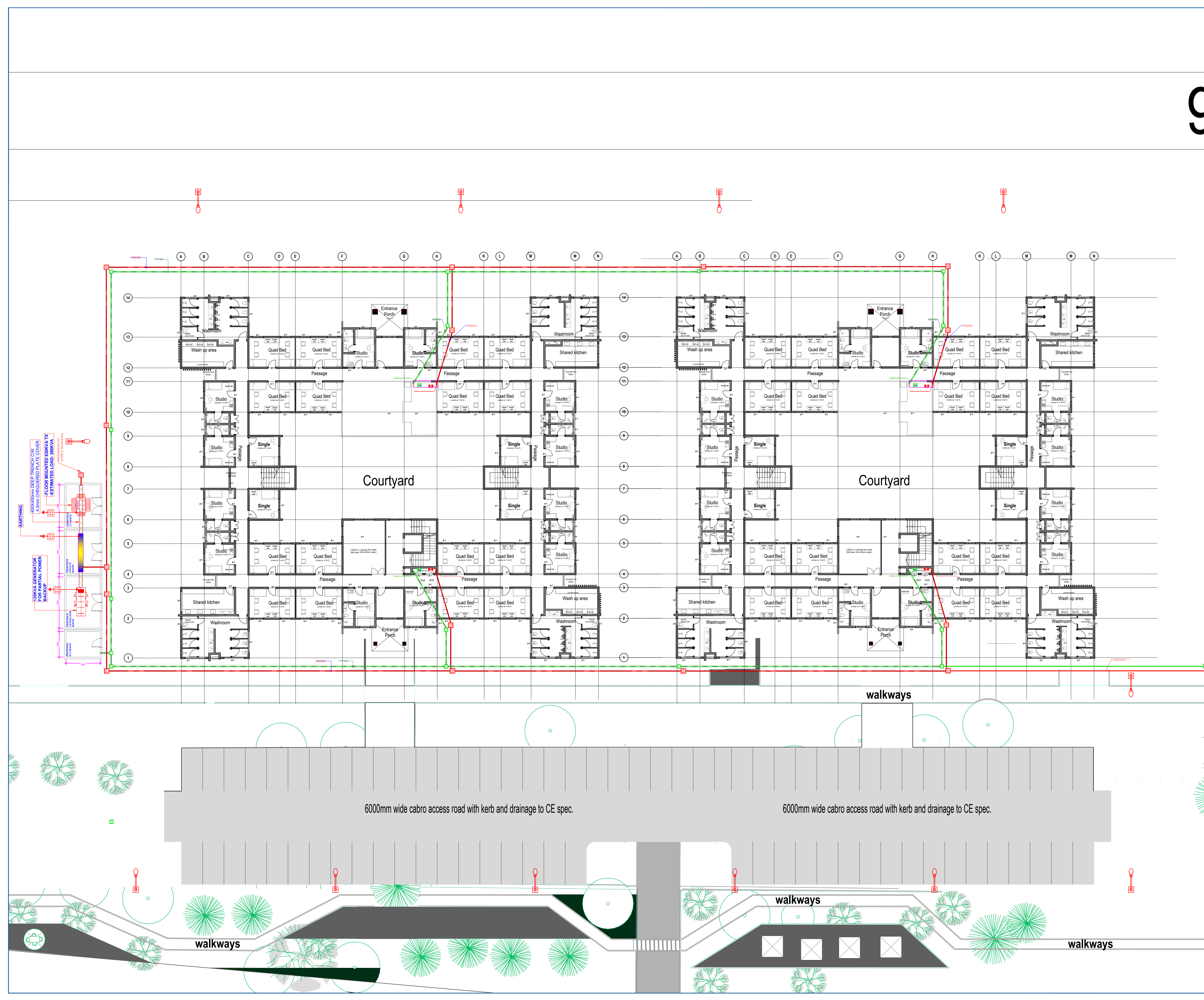

1. THIS DRAWING IS TO BE READ WITH ALL OTHER DISCIPLINES, DRAWINGS, SCHEDULES AND SPECIFICATIONS, LEGEND AND STANDARD DETAILS.
2. THIS DRAWING IS A COPYRIGHT AND SHALL NOT BE REPRODUCED WITHOUT PERMISSION.
3. DIMENSIONS GOVERN ON ALL DRAWINGS AND DETAILS. SHOULD ANY DISCREPANCIES BE FOUND WITH THIS DRAWING AND ANY ASSOCIATED DRAWINGS, OR SPECIFICATIONS THIS SHOULD BE BROUGHT TO THE ATTENTION OF M&E BUILDING SERVICES CONSULTANT IMMEDIATELY. UNLESS OTHERWISE STATED ALL DIMENSIONS ARE IN MILLIMETERS. DO NOT SCALE FROM THIS DRAWING.
4. DIMENSIONS TO BE CHECKED ON SITE BEFORE ANY WORKS IS PUT IN HAND OR PREFABRICATED.
5. THIS DRAWING SHOULD BE USED FOR THE SPECIFIC SERVICES INTENDED. THIS DRAWING SHOWS THE DESIGN INTEND ONLY. THE CONTRACTOR SHALL BE RESPONSIBLE FOR FULL CO-ORDINATION OF THE SERVICES INDICATED ON THIS AND ALL OTHER SERVICES DRAWINGS.
6. FINAL ACCESS AND SETTING OUT OF SERVICES SHALL BE AGREED BETWEEN THE ARCHITECT AND THE CONTRACTOR.
7. THE PROJECT NOTES ARE TO BE READ IN CONJUNCTION WITH ALL RELEVANT TECHNICAL SPECIFICATIONS.

LEGEND			
SYMBOL	DESCRIPTION	PHOTO	QTY
	1 Gang 1 Way Switch		
	2 Gang 2 Way Switch		
	Intermediate Switch		
	Motion Sensor		
	12W, Ceiling Rose		
	8W, Exit Light		
	10W, Surface LED Downlighter		
	1x18W, 4ft IP65 Fluorescent		
	100W, IP65 Bulkhead Fitting		
	16W, Bulkhead Lift Shaft		
	12W, Ball Fitting		
	Distribution Board		
	20A DP Switch with Neon Light		
	Twin Socket Outlet		
	4-Way Floor Box		
	Data Outlet		
	Bullet CCTV Camera		
	Dome CCTV Camera		
	Smoke Detectors		
	Break Glass		

REV	CHANGES	BY:	DATE:

CLIENT:
 STATE DEPARTMENT FOR HOUSING AND URBAN DEVELOPMENT

ARCHITECT:
 STRUCTURAL:
 QUANTITY SURVEYOR:

SITE: ALUPE STUDENT HOUSING
 TITLE: GROUND FLOOR ELECTRICAL LAYOUT
 SCALE: NOT TO SCALE
 DATE: _____ DRAWN: _____ CHECKED: _____
 PROJECT NO: _____ DRAWING NO: _____ REVISION: _____

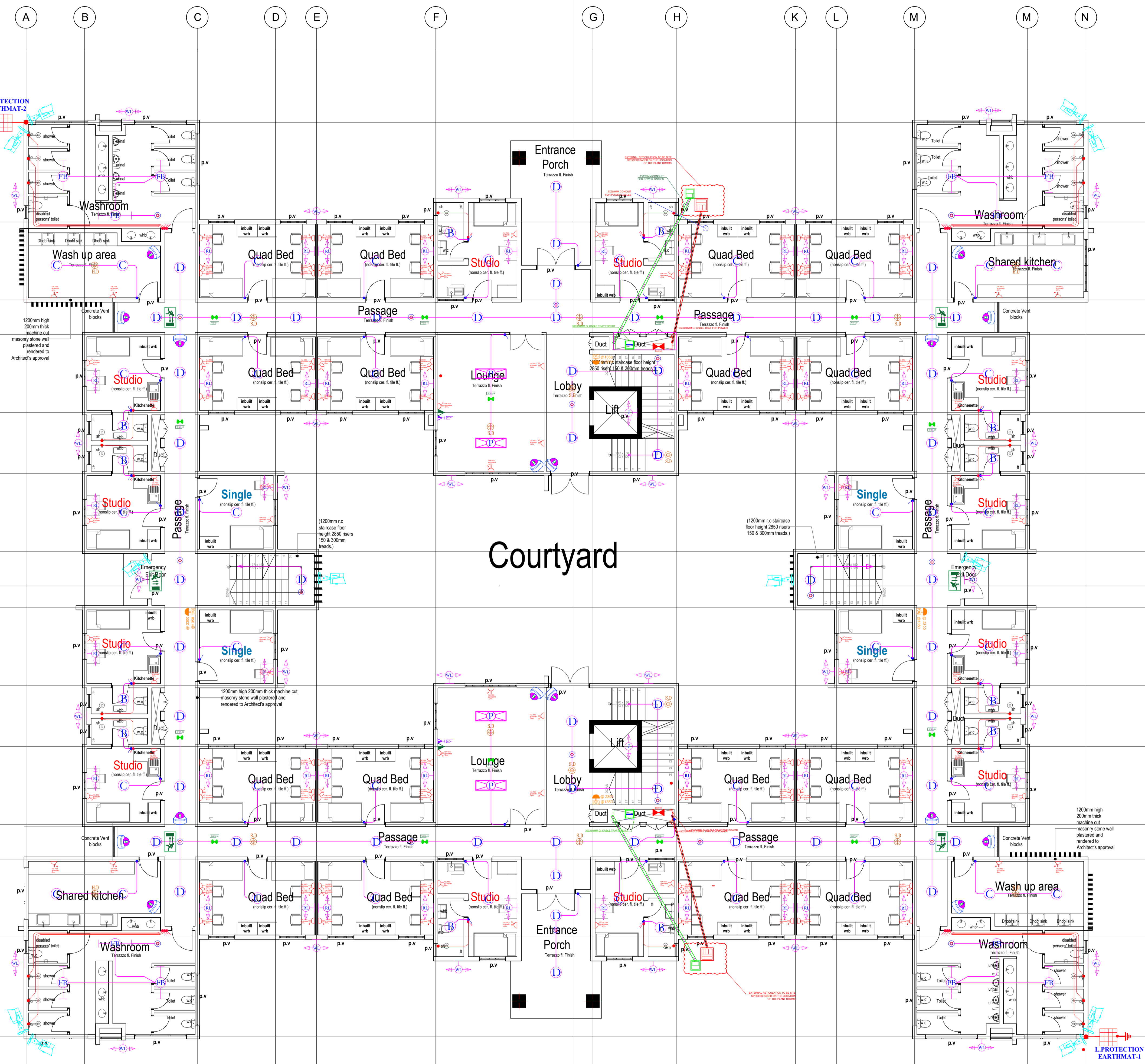

Courtyard

E-04

1. THIS DRAWING IS TO BE READ WITH ALL OTHER DISCIPLINES, DRAWINGS, SCHEDULES AND SPECIFICATIONS, LEGEND AND STANDARD DETAILS.
2. THIS DRAWING IS A COPYRIGHT AND SHALL NOT BE REPRODUCED WITHOUT PERMISSION.
3. DIMENSIONS GOVERN ON ALL DRAWINGS AND DETAILS. SHOULD ANY DISCREPANCIES BE FOUND WITH THIS DRAWING AND ANY ASSOCIATED DRAWINGS, OR SPECIFICATIONS THIS SHOULD BE BROUGHT TO THE ATTENTION OF M&E BUILDING SERVICES CONSULTANT IMMEDIATELY. UNLESS OTHERWISE STATED ALL DIMENSIONS ARE IN MILLIMETERS. DO NOT SCALE FROM THIS DRAWING.
4. DIMENSIONS TO BE CHECKED ON SITE BEFORE ANY WORKS IS PUT IN HAND OR PREFABRICATED.
5. THIS DRAWING SHOULD BE USED FOR THE SPECIFIC SERVICES INTENDED. THIS DRAWING SHOWS THE DESIGN INTEND ONLY. THE CONTRACTOR SHALL BE RESPONSIBLE FOR FULL CO-ORDINATION OF THE SERVICES INDICATED ON THIS AND ALL OTHER SERVICES DRAWINGS.
6. FINAL ACCESS AND SETTING OUT OF SERVICES SHALL BE AGREED BETWEEN THE ARCHITECT AND THE CONTRACTOR.
7. THE PROJECT NOTES ARE TO BE READ IN CONJUNCTION WITH ALL RELEVANT TECHNICAL SPECIFICATIONS.

LEGEND			
SYMBOL	DESCRIPTION	PHOTO	QTY
	1 Gang 1 Way Switch		
	2 Gang 2 Way Switch		
	Intermediate Switch		
	Motion Sensor		
	12W, Ceiling Rose		
	8W, Exit Light		
	10W, Surface LED Downlighter		
	1x18W, 4ft IP65 Fluorescent		
	100W, IP65 Bulkhead Fitting		
	16W, Bulkhead Lift Shaft		
	12W, Ball Fitting		
	Distribution Board		
	20A DP Switch with Neon Light		
	Twin Socket Outlet		
	4-Way Floor Box		
	Data Outlet		
	Bullet CCTV Camera		
	Dome CCTV Camera		
	Smoke Detectors		
	Break Glass		

REV	CHANGES	BY:	DATE:
RO	ELECTRICAL LAYOUTS	VK	.

CLIENT:
 STATE DEPARTMENT FOR HOUSING AND URBAN DEVELOPMENT

ARCHITECT:

STRUCTURAL:
 QUANTITY SURVEYOR:

SITE:
 ALUPE STUDENT HOUSING

TITLE:
 GROUND FLOOR LIGHTING, FIRE ALARM & CCTV LAYOUT

SCALE: NOT TO SCALE	DATE:	DRAWN:	CHECKED:
PROJECT NO:	DRAWING NO:	REVISION:	

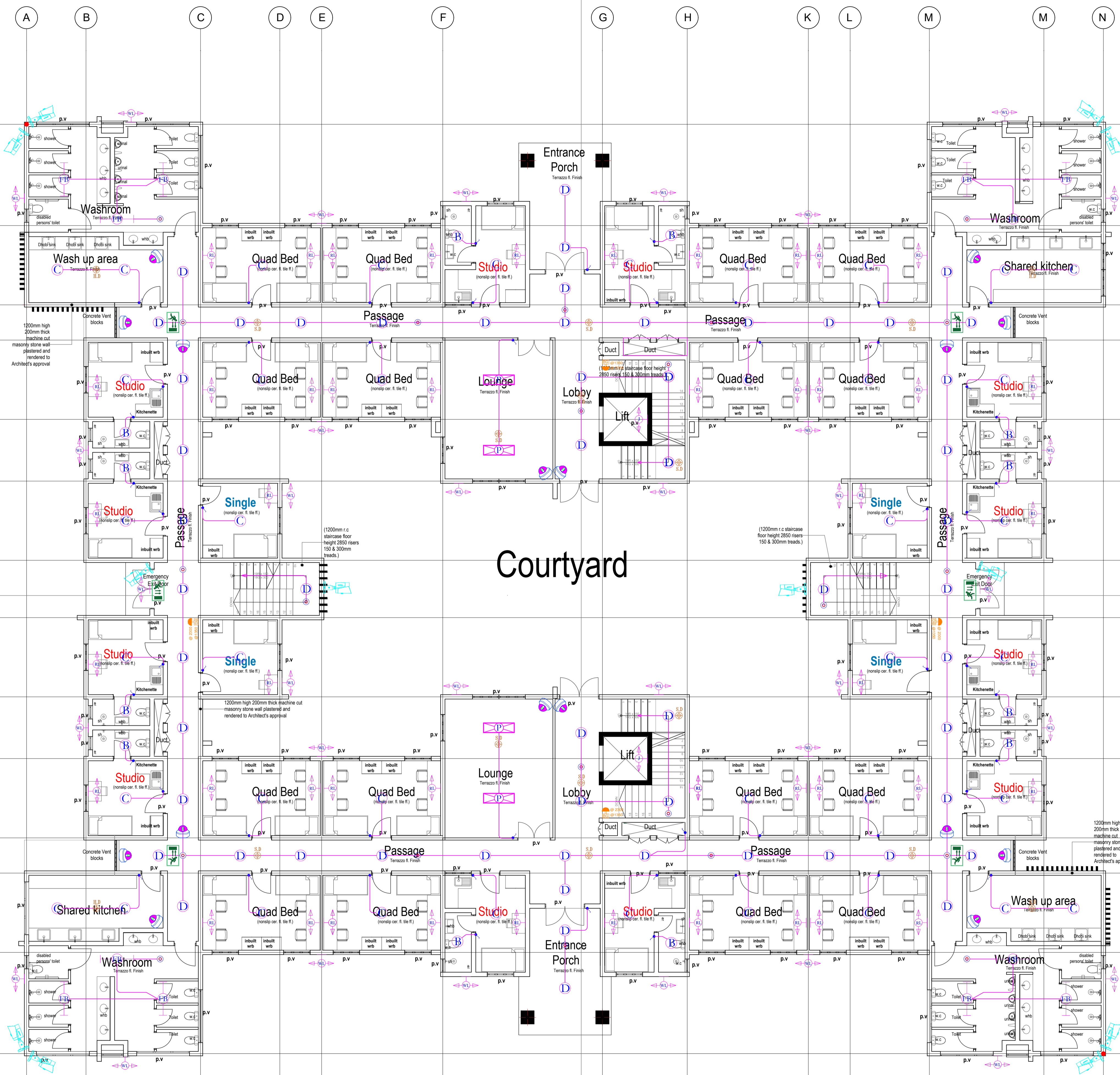

Courtyard

E-04

1. THIS DRAWING IS TO BE READ WITH ALL OTHER DISCIPLINES, DRAWINGS, SCHEDULES AND SPECIFICATIONS, LEGEND AND STANDARD DETAILS.
2. THIS DRAWING IS A COPYRIGHT AND SHALL NOT BE REPRODUCED WITHOUT PERMISSION.
3. DIMENSIONS GOVERN ON ALL DRAWINGS AND DETAILS. SHOULD ANY DISCREPANCIES BE FOUND WITH THIS DRAWING AND ANY ASSOCIATED DRAWINGS, OR SPECIFICATIONS THIS SHOULD BE BROUGHT TO THE ATTENTION OF M&E BUILDING SERVICES CONSULTANT IMMEDIATELY. UNLESS OTHERWISE STATED ALL DIMENSIONS ARE IN MILLIMETERS. DO NOT SCALE FROM THIS DRAWING.
4. DIMENSIONS TO BE CHECKED ON SITE BEFORE ANY WORKS IS PUT IN HAND OR PREFABRICATED.
5. THIS DRAWING SHOULD BE USED FOR THE SPECIFIC SERVICES INTENDED. THIS DRAWING SHOWS THE DESIGN INTEND ONLY. THE CONTRACTOR SHALL BE RESPONSIBLE FOR FULL CO-ORDINATION OF THE SERVICES INDICATED ON THIS AND ALL OTHER SERVICES DRAWINGS.
6. FINAL ACCESS AND SETTING OUT OF SERVICES SHALL BE AGREED BETWEEN THE ARCHITECT AND THE CONTRACTOR.
7. THE PROJECT NOTES ARE TO BE READ IN CONJUNCTION WITH ALL RELEVANT TECHNICAL SPECIFICATIONS.

LEGEND			
SYMBOL	DESCRIPTION	PHOTO	QTY
	1Gang 1 Way Switch		
	2Gang 2 Way Switch		
	Intermediate Switch		
	Motion Sensor		
	12W, Ceiling Rose		
	8W, Exit Light		
	10W, Surface LED Downlighter		
	1x18W, 4ft IP65 Fluorescent		
	100W, IP65 Bulkhead Fitting		
	16W, Bulkhead Lift Shaft		
	12W, Ball Fitting		
	Distribution Board		
	20A DP Switch with Neon Light		
	Twin Socket Outlet		
	4-Way Floor Box		
	Data Outlet		
	Bullet CCTV Camera		
	Dome CCTV Camera		
	Smoke Detectors		
	Break Glass		

REV	CHANGES	BY:	DATE:

CLIENT:
 STATE DEPARTMENT FOR HOUSING AND URBAN DEVELOPMENT

ARCHITECT:
 [Blank]

STRUCTURAL:
 [Blank]

QUANTITY SURVEYOR:
 [Blank]

SITE:
 ALUPE STUDENT HOUSING

TITLE:
 GROUND FLOOR POWER & DATA LAYOUT

SCALE: NOT TO SCALE	DATE:	DRAWN:	CHECKED:
PROJECT NO:	DRAWING NO:	REVISION:	

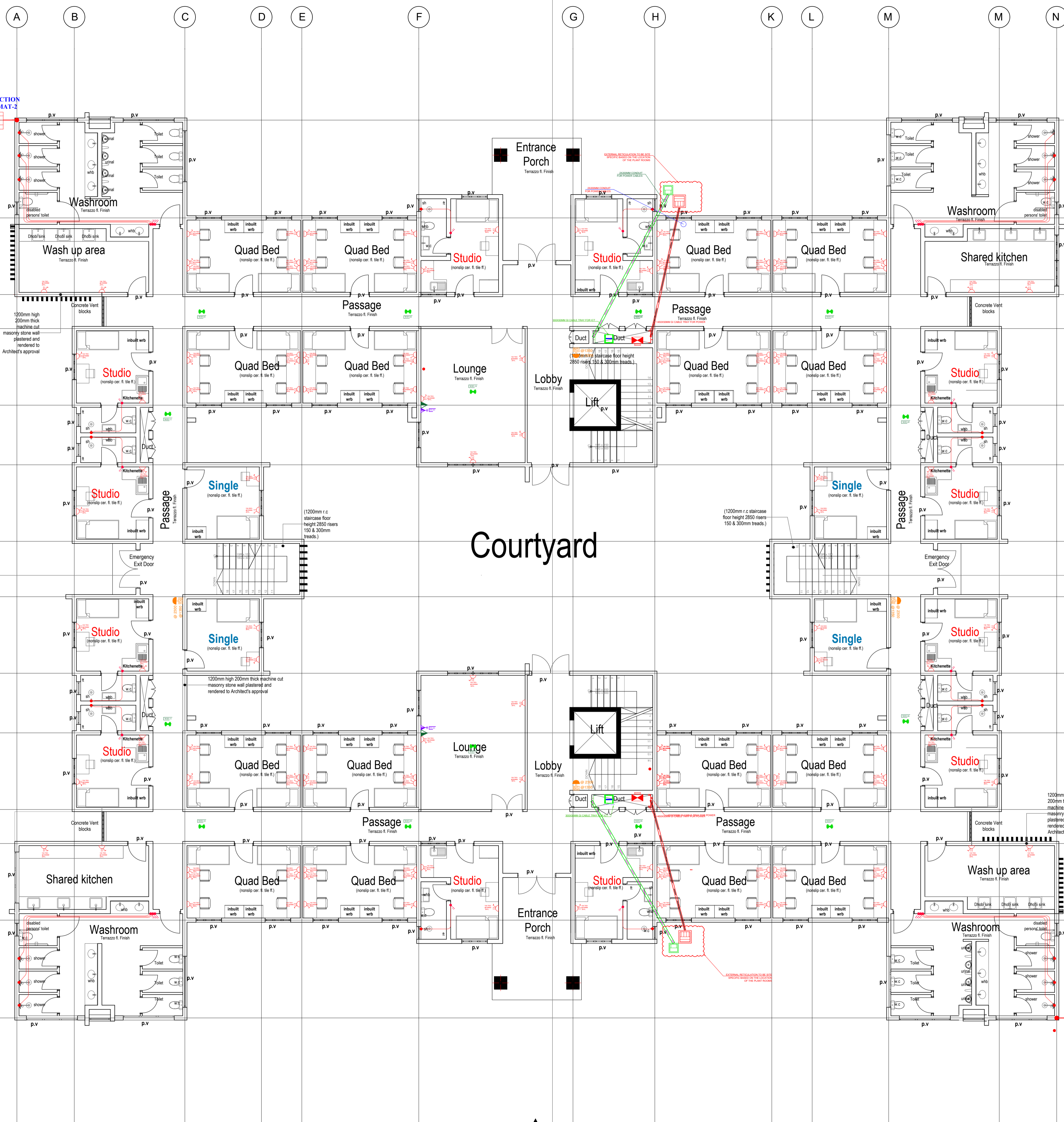

Courtyard

Entrance Porch

Lobby

Lift

Entrance Porch

L.PROTECTION EARTHIMAT-2

L.PROTECTION EARTHIMAT-1

1. THIS DRAWING IS TO BE READ WITH ALL OTHER DISCIPLINES, DRAWINGS, SCHEDULES AND SPECIFICATIONS, LEGEND AND STANDARD DETAILS.
2. THIS DRAWING IS A COPYRIGHT AND SHALL NOT BE REPRODUCED WITHOUT PERMISSION.
3. DIMENSIONS GOVERN ON ALL DRAWINGS AND DETAILS. SHOULD ANY DISCREPANCIES BE FOUND WITH THIS DRAWING AND ANY ASSOCIATED DRAWINGS, OR SPECIFICATIONS THIS SHOULD BE BROUGHT TO THE ATTENTION OF M&E BUILDING SERVICES CONSULTANT IMMEDIATELY. UNLESS OTHERWISE STATED ALL DIMENSIONS ARE IN MILLIMETERS. DO NOT SCALE FROM THIS DRAWING.
4. DIMENSIONS TO BE CHECKED ON SITE BEFORE ANY WORKS IS PUT IN HAND OR PREFABRICATED.
5. THIS DRAWING SHOULD BE USED FOR THE SPECIFIC SERVICES INTENDED. THIS DRAWING SHOWS THE DESIGN INTEND ONLY. THE CONTRACTOR SHALL BE RESPONSIBLE FOR FULL CO-ORDINATION OF THE SERVICES INDICATED ON THIS AND ALL OTHER SERVICES DRAWINGS.
6. FINAL ACCESS AND SETTING OUT OF SERVICES SHALL BE AGREED BETWEEN THE ARCHITECT AND THE CONTRACTOR.
7. THE PROJECT NOTES ARE TO BE READ IN CONJUNCTION WITH ALL RELEVANT TECHNICAL SPECIFICATIONS.

LEGEND			
SYMBOL	DESCRIPTION	PHOTO	QTY
	1Gang 1 Way Switch		
	2Gang 2 Way Switch		
	Intermediate Switch		
	Motion Sensor		
	12W, Ceiling Rose		
	8W, Exit Light		
	10W, Surface LED Downlighter		
	1x18W, 4ft IP65 Fluorescent		
	100W, IP65 Bulkhead Fitting		
	16W, Bulkhead Lift Shaft		
	12W, Ball Fitting		
	Distribution Board		
	20A DP Switch with Neon Light		
	Twin Socket Outlet		
	4-Way Floor Box		
	Data Outlet		
	Bullet CCTV Camera		
	Dome CCTV Camera		
	Smoke Detectors		
	Break Glass		

REV	CHANGES	BY:	DATE:

CLIENT:
 STATE DEPARTMENT FOR HOUSING AND URBAN DEVELOPMENT

ARCHITECT:
 STRUCTURAL:
 QUANTITY SURVEYOR:

SITE:
 ALUPE STUDENT HOUSING

TITLE:
 FIRST FLOOR ELECTRICAL LAYOUT

SCALE: NOT TO SCALE	DATE:	DRAWN:	CHECKED:
PROJECT NO:	DRAWING NO:	REVISION:	

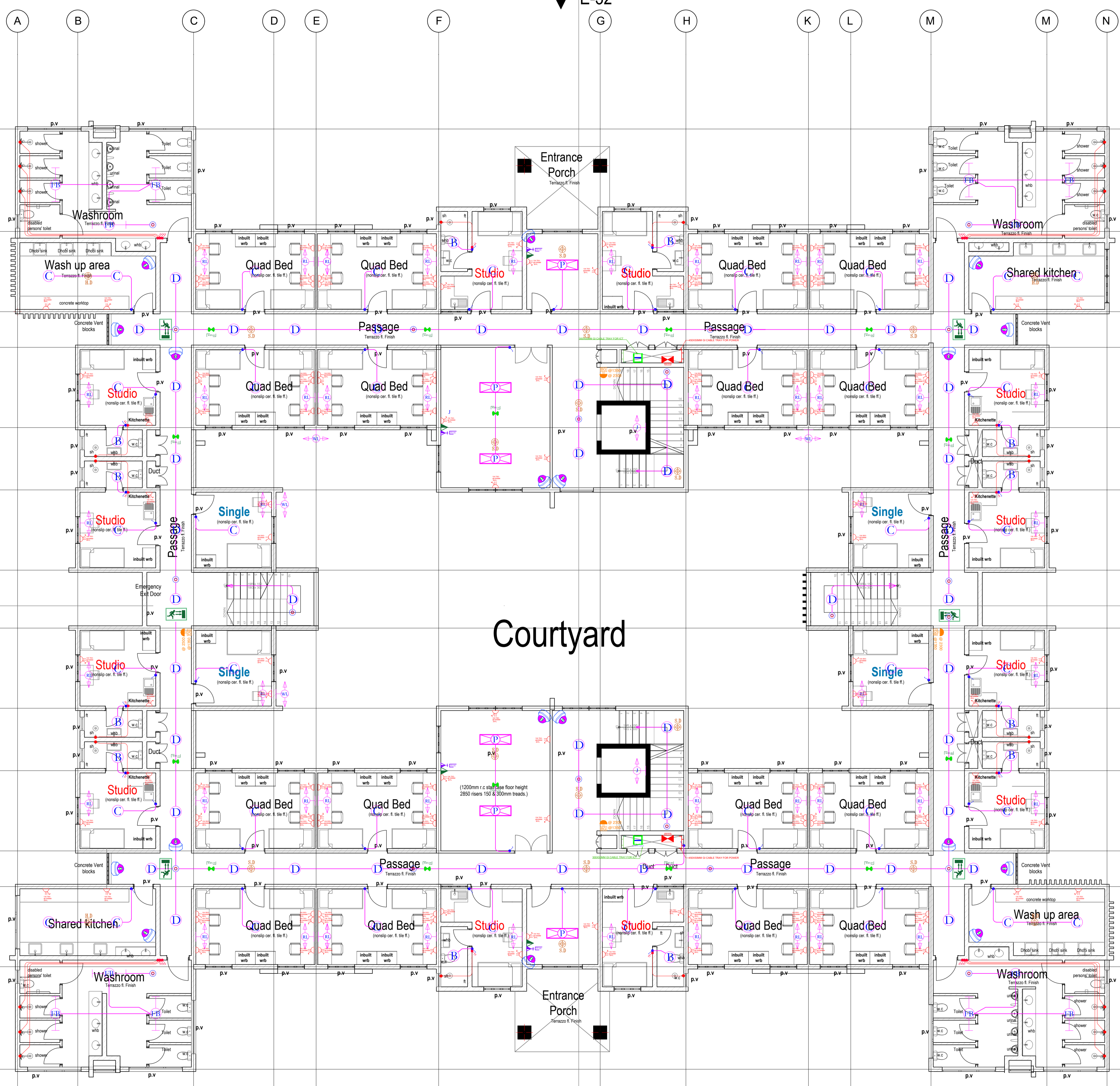

Courtyard

E-33

1. THIS DRAWING IS TO BE READ WITH ALL OTHER DISCIPLINES, DRAWINGS, SCHEDULES AND SPECIFICATIONS, LEGEND AND STANDARD DETAILS.
2. THIS DRAWING IS A COPYRIGHT AND SHALL NOT BE REPRODUCED WITHOUT PERMISSION.
3. DIMENSIONS GOVERN ON ALL DRAWINGS AND DETAILS. SHOULD ANY DISCREPANCIES BE FOUND WITH THIS DRAWING AND ANY ASSOCIATED DRAWINGS, OR SPECIFICATIONS THIS SHOULD BE BROUGHT TO THE ATTENTION OF M&E BUILDING SERVICES CONSULTANT IMMEDIATELY.
4. UNLESS OTHERWISE STATED ALL DIMENSIONS ARE IN MILLIMETERS.
5. DO NOT SCALE FROM THIS DRAWING.
6. DIMENSIONS TO BE CHECKED ON SITE BEFORE ANY WORKS IS PUT IN HAND OR PREFABRICATED.
7. THIS DRAWING SHOULD BE USED FOR THE SPECIFIC SERVICES INTENDED.
8. THIS DRAWING SHOWS THE DESIGN INTEND ONLY. THE CONTRACTOR SHALL BE RESPONSIBLE FOR FULL CO-ORDINATION OF THE SERVICES INDICATED ON THIS AND ALL OTHER SERVICES DRAWINGS.
9. FINAL ACCESS AND SETTING OUT OF SERVICES SHALL BE AGREED BETWEEN THE ARCHITECT AND THE CONTRACTOR.
10. THE PROJECT NOTES ARE TO BE READ IN CONJUNCTION WITH ALL RELEVANT TECHNICAL SPECIFICATIONS.

LEGEND			
SYMBOL	DESCRIPTION	PHOTO	QTY
	1Gang 1 Way Switch		
	2Gang 2 Way Switch		
	Intermediate Switch		
	Motion Sensor		
	12W, Ceiling Rose		
	8W, Exit Light		
	10W, Surface LED Downlighter		
	1x18W, 4ft IP65 Fluorescent		
	100W, IP65 Bulkhead Fitting		
	16W, Bulkhead Lift Shaft		
	12W, Ball Fitting		
	Distribution Board		
	20A DP Switch with Neon Light		
	Twin Socket Outlet		
	4-Way Floor Box		
	Data Outlet		
	Bullet CCTV Camera		
	Dome CCTV Camera		
	Smoke Detectors		
	Break Glass		

REV	CHANGES	BY:	DATE:

CLIENT:
 STATE DEPARTMENT FOR HOUSING AND URBAN DEVELOPMENT

ARCHITECT:
 STRUCTURAL:
 QUANTITY SURVEYOR:

SITE:
 ALUPE STUDENT HOUSING

TITLE:
 FIRST FLOOR LIGHTING, FIRE ALARM & CCTV LAYOUT

SCALE: NOT TO SCALE

DATE:	DRAWN:	CHECKED:
PROJECT NO:	DRAWING NO:	REVISION:

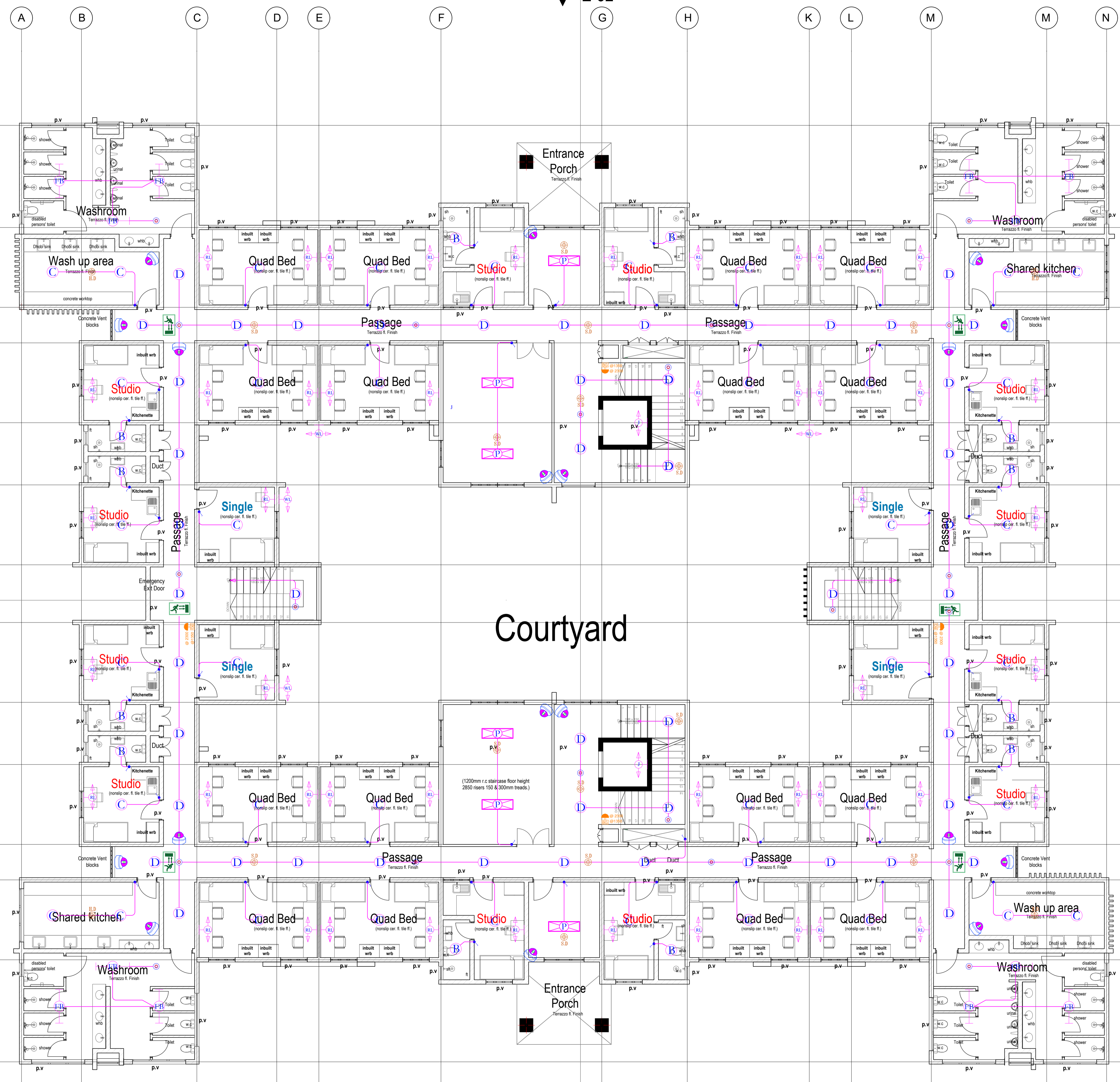

1. THIS DRAWING IS TO BE READ WITH ALL OTHER DISCIPLINES, DRAWINGS, SCHEDULES AND SPECIFICATIONS, LEGEND AND STANDARD DETAILS.
2. THIS DRAWING IS A COPYRIGHT AND SHALL NOT BE REPRODUCED WITHOUT PERMISSION.
3. DIMENSIONS GOVERN ON ALL DRAWINGS AND DETAILS. SHOULD ANY DISCREPANCIES BE FOUND WITH THIS DRAWING AND ANY ASSOCIATED DRAWINGS, OR SPECIFICATIONS THIS SHOULD BE BROUGHT TO THE ATTENTION OF THE BUILDING SERVICES CONSULTANT IMMEDIATELY. UNLESS OTHERWISE STATED ALL DIMENSIONS ARE IN MILLIMETERS. DO NOT SCALE FROM THIS DRAWING.
4. DIMENSIONS TO BE CHECKED ON SITE BEFORE ANY WORKS IS PUT IN HAND OR PREFABRICATED.
5. THIS DRAWING SHOULD BE USED FOR THE SPECIFIC SERVICES INTENDED. THIS DRAWING SHOWS THE DESIGN INTEND ONLY. THE CONTRACTOR SHALL BE RESPONSIBLE FOR FULL CO-ORDINATION OF THE SERVICES INDICATED ON THIS AND ALL OTHER SERVICES DRAWINGS.
6. FINAL ACCESS AND SETTING OUT OF SERVICES SHALL BE AGREED BETWEEN THE ARCHITECT AND THE CONTRACTOR.
7. THE PROJECT NOTES ARE TO BE READ IN CONJUNCTION WITH ALL RELEVANT TECHNICAL SPECIFICATIONS.

LEGEND			
SYMBOL	DESCRIPTION	PHOTO	QTY
	1Gang 1 Way Switch		
	2Gang 2 Way Switch		
	Intermediate Switch		
	Motion Sensor		
	12W, Ceiling Rose		
	8W, Exit Light		
	10W, Surface LED Downlighter		
	1x18W, 4ft IP65 Fluorescent		
	100W, IP65 Bulkhead Fitting		
	16W, Bulkhead Lift Shaft		
	12W, Ball Fitting		
	Distribution Board		
	20A DP Switch with Neon Light		
	Twin Socket Outlet		
	4-Way Floor Box		
	Data Outlet		
	Bullet CCTV Camera		
	Dome CCTV Camera		
	Smoke Detectors		
	Break Glass		

REV	CHANGES	BY:	DATE:

CLIENT:
 STATE DEPARTMENT FOR HOUSING AND URBAN DEVELOPMENT

ARCHITECT:
 STRUCTURAL:
 QUANTITY SURVEYOR:

SITE:
 ALUPE STUDENT HOUSING

TITLE:
 FIRST FLOOR POWER & DATA LAYOUT

SCALE: NOT TO SCALE	DATE:	DRAWN:	CHECKED:
PROJECT NO:	DRAWING NO:	REVISION:	

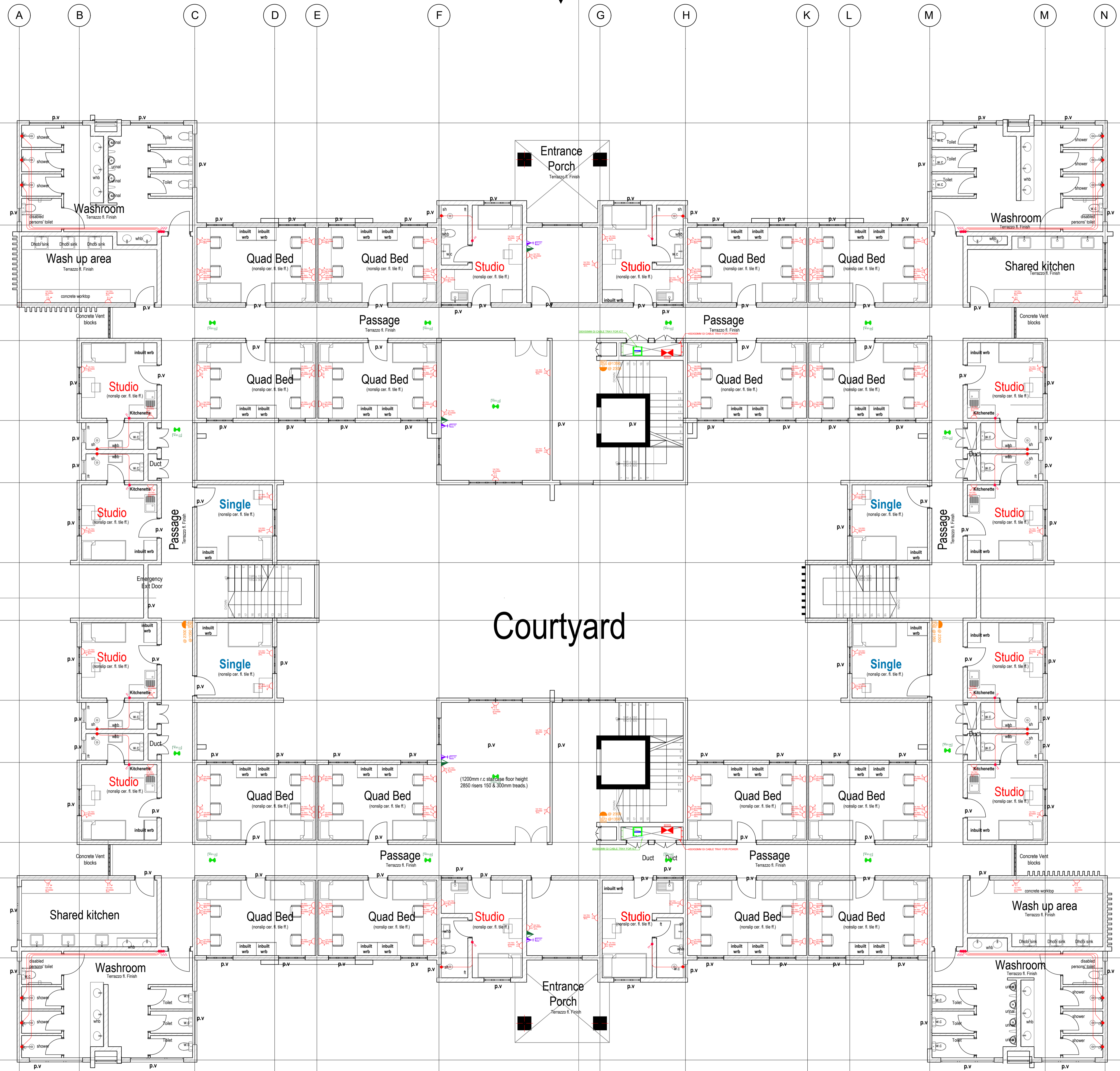

Notes:

1. THIS DRAWING IS TO BE READ WITH ALL OTHER DISCIPLINES, DRAWINGS, SCHEDULES AND SPECIFICATIONS, LEGEND AND STANDARD DETAILS.
2. THIS DRAWING IS A COPYRIGHT AND SHALL NOT BE REPRODUCED WITHOUT PERMISSION.
3. DIMENSIONS GOVERN ON ALL DRAWINGS AND DETAILS. SHOULD ANY DISCREPANCIES BE FOUND WITH THIS DRAWING AND ANY ASSOCIATED DRAWINGS, OR SPECIFICATIONS THIS SHOULD BE BROUGHT TO THE ATTENTION OF M&E BUILDING SERVICES CONSULTANT IMMEDIATELY. UNLESS OTHERWISE STATED ALL DIMENSIONS ARE IN MILLIMETERS. DO NOT SCALE FROM THIS DRAWING.
4. DIMENSIONS TO BE CHECKED ON SITE BEFORE ANY WORKS IS PUT IN HAND OR PREFABRICATED.
5. THIS DRAWING SHOULD BE USED FOR THE SPECIFIC SERVICES INTENDED. THIS DRAWING SHOWS THE DESIGN INTEND ONLY. THE CONTRACTOR SHALL BE RESPONSIBLE FOR FULL CO-ORDINATION OF THE SERVICES INDICATED ON THIS AND ALL OTHER SERVICES DRAWINGS.
6. FINAL ACCESS AND SETTING OUT OF SERVICES SHALL BE AGREED BETWEEN THE ARCHITECT AND THE CONTRACTOR.
7. THE PROJECT NOTES ARE TO BE READ IN CONJUNCTION WITH ALL RELEVANT TECHNICAL SPECIFICATIONS.

LEGEND			
SYMBOL	DESCRIPTION	PHOTO	QTY
	1Gang 1 Way Switch		
	2Gang 2 Way Switch		
	Intermediate Switch		
	Motion Sensor		
	12W, Ceiling Rose		
	8W, Exit Light		
	10W, Surface LED Downlighter		
	1x18W, 4ft IP65 Fluorescent		
	100W, IP65 Bulkhead Fitting		
	16W, Bulkhead Lift Shaft		
	12W, Ball Fitting		
	Distribution Board		
	20A DP Switch with Neon Light		
	Twin Socket Outlet		
	4-Way Floor Box		
	Data Outlet		
	Bullet CCTV Camera		
	Dome CCTV Camera		
	Smoke Detectors		
	Break Glass		

REV	CHANGES	BY:	DATE:

CLIENT:
 STATE DEPARTMENT FOR HOUSING AND URBAN DEVELOPMENT

ARCHITECT:
 STRUCTURAL:
 QUANTITY SURVEYOR:

SITE:
 ALUPE STUDENT HOUSING

TITLE:
 TYPICAL 2ND- 9TH FLOOR ELECTRICAL LAYOUT

SCALE: NOT TO SCALE	DATE:	DRAWN:	CHECKED:
PROJECT NO:	DRAWING NO:	REVISION:	

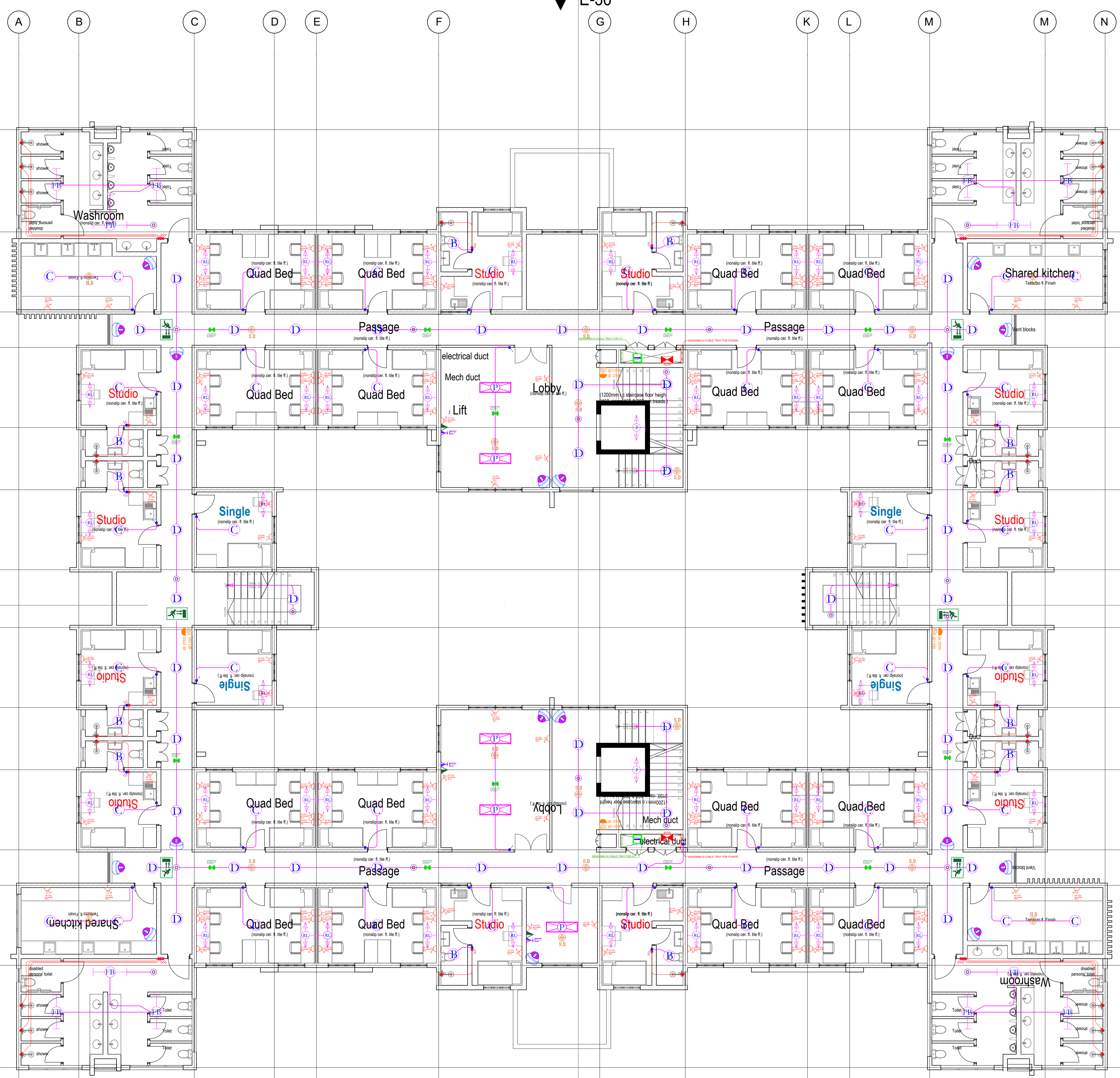

E-37

E-35

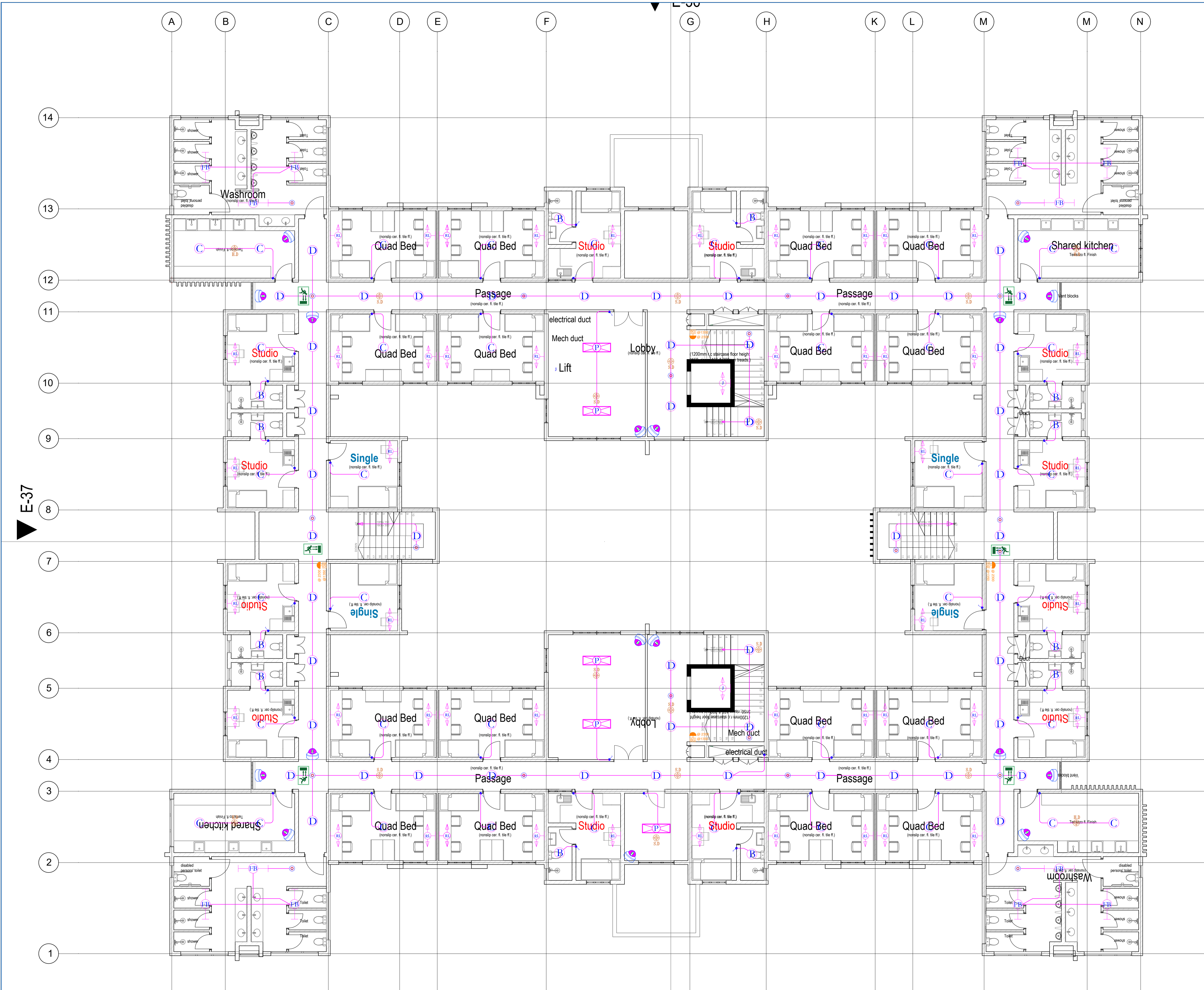

E-37

Notes:

1. THIS DRAWING IS TO BE READ WITH ALL OTHER DISCIPLINES, DRAWINGS, SCHEDULES AND SPECIFICATIONS, LEGEND AND STANDARD DETAILS.
2. THIS DRAWING IS A COPYRIGHT AND SHALL NOT BE REPRODUCED WITHOUT PERMISSION.
3. DIMENSIONS GOVERN ON ALL DRAWINGS AND DETAILS. SHOULD ANY DISCREPANCIES BE FOUND WITH THIS DRAWING AND ANY ASSOCIATED DRAWINGS, OR SPECIFICATIONS THIS SHOULD BE BROUGHT TO THE ATTENTION OF M&E BUILDING SERVICES CONSULTANT IMMEDIATELY. UNLESS OTHERWISE STATED ALL DIMENSIONS ARE IN MILLIMETERS. DO NOT SCALE FROM THIS DRAWING.
4. DIMENSIONS TO BE CHECKED ON SITE BEFORE ANY WORKS IS PUT IN HAND OR PREFABRICATED.
5. THIS DRAWING SHOULD BE USED FOR THE SPECIFIC SERVICES INTENDED. THIS DRAWING SHOWS THE DESIGN INTEND ONLY. THE CONTRACTOR SHALL BE RESPONSIBLE FOR FULL CO-ORDINATION OF THE SERVICES INDICATED ON THIS AND ALL OTHER SERVICES DRAWINGS.
6. FINAL ACCESS AND SETTING OUT OF SERVICES SHALL BE AGREED BETWEEN THE ARCHITECT AND THE CONTRACTOR.
7. THE PROJECT NOTES ARE TO BE READ IN CONJUNCTION WITH ALL RELEVANT TECHNICAL SPECIFICATIONS.

LEGEND			
SYMBOL	DESCRIPTION	PHOTO	QTY
	1Gang 1 Way Switch		
	2Gang 2 Way Switch		
	Intermediate Switch		
	Motion Sensor		
	12W, Ceiling Rose		
	8W, Exit Light		
	10W, Surface LED Downlighter		
	1x18W, 4ft IP65 Fluorescent		
	100W, IP65 Bulkhead Fitting		
	16W, Bulkhead Lift Shaft		
	12W, Ball Fitting		
	Distribution Board		
	20A DP Switch with Neon Light		
	Twin Socket Outlet		
	4-Way Floor Box		
	Data Outlet		
	Bullet CCTV Camera		
	Dome CCTV Camera		
	Smoke Detectors		
	Break Glass		

REV	CHANGES	BY:	DATE:

CLIENT:
 STATE DEPARTMENT FOR HOUSING AND URBAN DEVELOPMENT

ARCHITECT:
 STRUCTURAL:
 QUANTITY SURVEYOR:

SITE:
 ALUPE STUDENT HOUSING

TITLE: TYPICAL 2ND- 9TH FLOOR LIGHTING, FIRE ALARM & CCTV LAYOUT			
SCALE: NOT TO SCALE	DATE:	DRAWN:	CHECKED:
PROJECT NO:	DRAWING NO:	REVISION:	

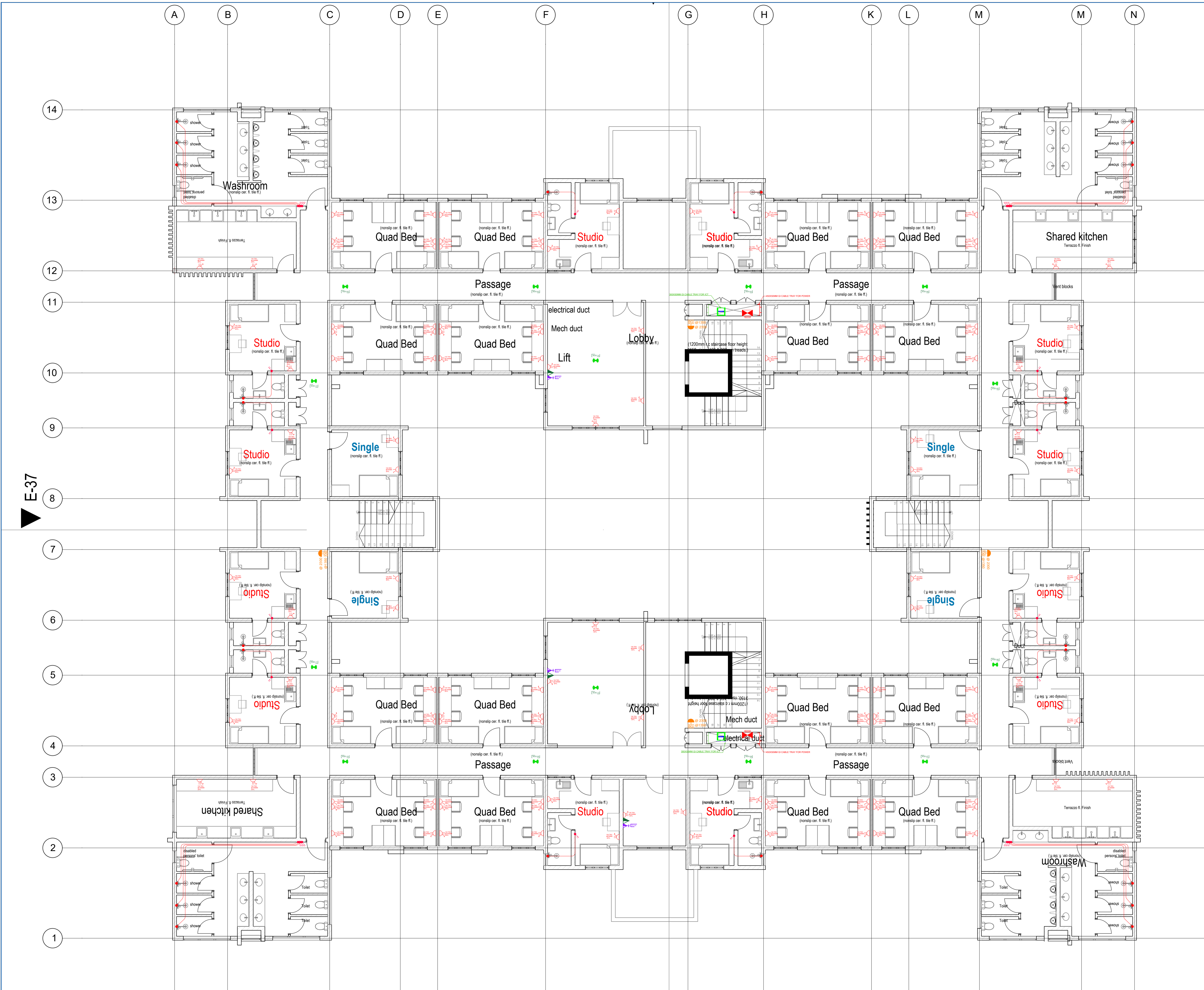

E-37

Notes:

1. THIS DRAWING IS TO BE READ WITH ALL OTHER DISCIPLINES, DRAWINGS, SCHEDULES AND SPECIFICATIONS, LEGEND AND STANDARD DETAILS.
2. THIS DRAWING IS A COPYRIGHT AND SHALL NOT BE REPRODUCED WITHOUT PERMISSION.
3. DIMENSIONS GOVERN ON ALL DRAWINGS AND DETAILS. SHOULD ANY DISCREPANCIES BE FOUND WITH THIS DRAWING AND ANY ASSOCIATED DRAWINGS, OR SPECIFICATIONS THIS SHOULD BE BROUGHT TO THE ATTENTION OF M&E BUILDING SERVICES CONSULTANT IMMEDIATELY. UNLESS OTHERWISE STATED ALL DIMENSIONS ARE IN MILLIMETERS. DO NOT SCALE FROM THIS DRAWING.
4. DIMENSIONS TO BE CHECKED ON SITE BEFORE ANY WORKS IS PUT IN HAND OR PREFABRICATED.
5. THIS DRAWING SHOULD BE USED FOR THE SPECIFIC SERVICES INTENDED. THIS DRAWING SHOWS THE DESIGN INTEND ONLY. THE CONTRACTOR SHALL BE RESPONSIBLE FOR FULL CO-ORDINATION OF THE SERVICES INDICATED ON THIS AND ALL OTHER SERVICES DRAWINGS.
6. FINAL ACCESS AND SETTING OUT OF SERVICES SHALL BE AGREED BETWEEN THE ARCHITECT AND THE CONTRACTOR.
7. THE PROJECT NOTES ARE TO BE READ IN CONJUNCTION WITH ALL RELEVANT TECHNICAL SPECIFICATIONS.

LEGEND			
SYMBOL	DESCRIPTION	PHOTO	QTY
	1Gang 1 Way Switch		
	2Gang 2 Way Switch		
	Intermediate Switch		
	Motion Sensor		
	12W, Ceiling Rose		
	8W, Exit Light		
	10W, Surface LED Downlighter		
	1x18W, 4ft IP65 Fluorescent		
	100W, IP65 Bulkhead Fitting		
	16W, Bulkhead Lift Shaft		
	12W, Ball Fitting		
	Distribution Board		
	20A DP Switch with Neon Light		
	Twin Socket Outlet		
	4-Way Floor Box		
	Data Outlet		
	Bullet CCTV Camera		
	Dome CCTV Camera		
	Smoke Detectors		
	Break Glass		

REV	CHANGES	BY:	DATE:

CLIENT:
 STATE DEPARTMENT FOR HOUSING AND URBAN DEVELOPMENT

ARCHITECT:

STRUCTURAL:
 QUANTITY SURVEYOR:

SITE:
ALUPE STUDENT HOUSING

TITLE:
TYPICAL 2ND- 9TH FLOOR POWER & DATA LAYOUT

SCALE: NOT TO SCALE	DATE:	DRAWN:	CHECKED:
PROJECT NO:	DRAWING NO:	REVISION:	

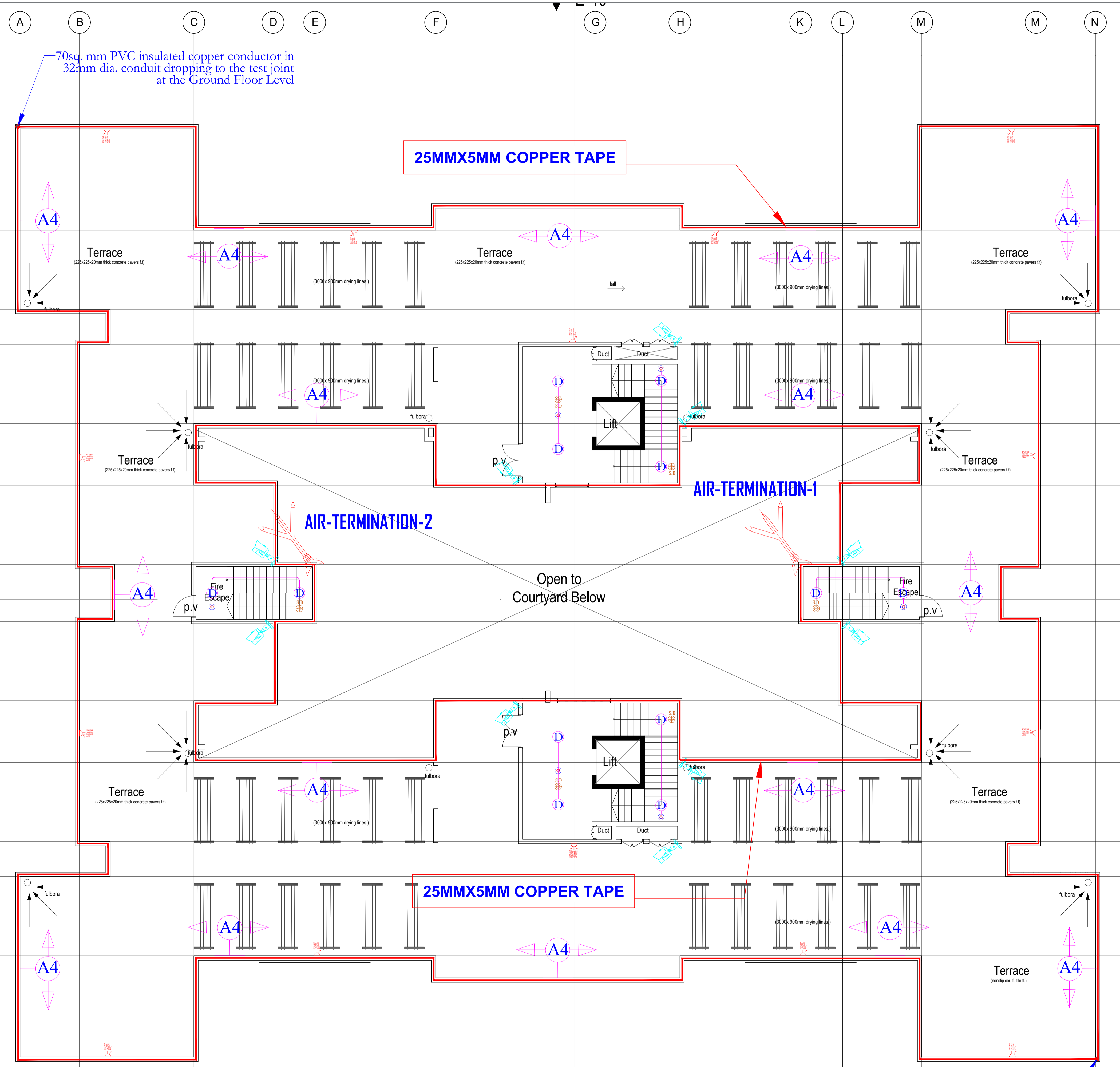

- Notes:
1. THIS DRAWING IS TO BE READ WITH ALL OTHER DISCIPLINES, DRAWINGS, SCHEDULES AND SPECIFICATIONS, LEGEND AND STANDARD DETAILS.
 2. THIS DRAWING IS A COPYRIGHT AND SHALL NOT BE REPRODUCED WITHOUT PERMISSION.
 3. DIMENSIONS GOVERN ON ALL DRAWINGS AND DETAILS. SHOULD ANY DISCREPANCIES BE FOUND WITH THIS DRAWING AND ANY ASSOCIATED DRAWINGS, OR SPECIFICATIONS THIS SHOULD BE BROUGHT TO THE ATTENTION OF M&E BUILDING SERVICES CONSULTANT IMMEDIATELY.
 4. UNLESS OTHERWISE STATED ALL DIMENSIONS ARE IN MILLIMETERS. DO NOT SCALE FROM THIS DRAWING.
 5. DIMENSIONS TO BE CHECKED ON SITE BEFORE ANY WORKS IS PUT IN HAND OR PREFABRICATED.
 6. THIS DRAWING SHOULD BE USED FOR THE SPECIFIC SERVICES INTENDED.
 7. THIS DRAWING SHOWS THE DESIGN INTEND ONLY. THE CONTRACTOR SHALL BE RESPONSIBLE FOR FULL CO-ORDINATION OF THE SERVICES INDICATED ON THIS AND ALL OTHER SERVICES DRAWINGS.
 8. FINAL ACCESS AND SETTING OUT OF SERVICES SHALL BE AGREED BETWEEN THE ARCHITECT AND THE CONTRACTOR.
 9. THE PROJECT NOTES ARE TO BE READ IN CONJUNCTION WITH ALL RELEVANT TECHNICAL SPECIFICATIONS.

LEGEND			
SYMBOL	DESCRIPTION	PHOTO	QTY
	1Gang 1 Way Switch		
	2Gang 2 Way Switch		
	Intermediate Switch		
	Motion Sensor		
	12W, Ceiling Rose		
	8W, Exit Light		
	10W, Surface LED Downlighter		
	1x18W, 4ft IP65 Fluorescent		
	100W, IP65 Bulkhead Fitting		
	16W, Bulkhead Lift Shaft		
	12W, Ball Fitting		
	Distribution Board		
	20A DP Switch with Neon Light		
	Twin Socket Outlet		
	4-Way Floor Box		
	Data Outlet		
	Bullet CCTV Camera		
	Dome CCTV Camera		
	Smoke Detectors		
	Break Glass		

REV	CHANGES	BY:	DATE:

CLIENT:
 STATE DEPARTMENT FOR HOUSING AND URBAN DEVELOPMENT

ARCHITECT:

STRUCTURAL:
 QUANTITY SURVEYOR:

SITE: ALUPE STUDENT HOUSING

TITLE: ROOF TERRACE ELECTRICAL LAYOUT

SCALE: NOT TO SCALE	DATE:	DRAWN:	CHECKED:
PROJECT NO:	DRAWING NO:	REVISION:	

E-41

1. THIS DRAWING IS TO BE READ WITH ALL OTHER DISCIPLINES, DRAWINGS, SCHEDULES AND SPECIFICATIONS, LEGEND AND STANDARD DETAILS.
2. THIS DRAWING IS A COPYRIGHT AND SHALL NOT BE REPRODUCED WITHOUT PERMISSION.
3. DIMENSIONS GOVERN ON ALL DRAWINGS AND DETAILS. SHOULD ANY DISCREPANCIES BE FOUND WITH THIS DRAWING AND ANY ASSOCIATED DRAWINGS, OR SPECIFICATIONS THIS SHOULD BE BROUGHT TO THE ATTENTION OF M&E BUILDING SERVICES CONSULTANT IMMEDIATELY.
4. UNLESS OTHERWISE STATED ALL DIMENSIONS ARE IN MILLIMETERS. DO NOT SCALE FROM THIS DRAWING.
5. DIMENSIONS TO BE CHECKED ON SITE BEFORE ANY WORKS IS PUT IN HAND OR PREFABRICATED.
6. THIS DRAWING SHOULD BE USED FOR THE SPECIFIC SERVICES INTENDED.
7. THIS DRAWING SHOWS THE DESIGN INTEND ONLY. THE CONTRACTOR SHALL BE RESPONSIBLE FOR FULL CO-ORDINATION OF THE SERVICES INDICATED ON THIS AND ALL OTHER SERVICES DRAWINGS.
8. FINAL ACCESS AND SETTING OUT OF SERVICES SHALL BE AGREED BETWEEN THE ARCHITECT AND THE CONTRACTOR.
9. THE PROJECT NOTES ARE TO BE READ IN CONJUNCTION WITH ALL RELEVANT TECHNICAL SPECIFICATIONS.

LEGEND			
SYMBOL	DESCRIPTION	PHOTO	QTY
	1Gang 1 Way Switch		
	2Gang 2 Way Switch		
	Intermediate Switch		
	Motion Sensor		
	12W, Ceiling Rose		
	8W, Exit Light		
	10W, Surface LED Downlighter		
	1x18W, 4ft IP65 Fluorescent		
	100W, IP65 Bulkhead Fitting		
	16W, Bulkhead Lift Shaft		
	12W, Ball Fitting		
	Distribution Board		
	20A DP Switch with Neon Light		
	Twin Socket Outlet		
	4-Way Floor Box		
	Data Outlet		
	Bullet CCTV Camera		
	Dome CCTV Camera		
	Smoke Detectors		
	Break Glass		

REV	CHANGES	BY:	DATE:

CLIENT:
 STATE DEPARTMENT FOR HOUSING AND URBAN DEVELOPMENT

ARCHITECT:
 STRUCTURAL:
 QUANTITY SURVEYOR:

SITE:
 ALUPE STUDENT HOUSING

TITLE:
 LIGHTNING PROTECTION LAYOUT

SCALE: NOT TO SCALE	DATE:	DRAWN:	CHECKED:
PROJECT NO:	DRAWING NO:	REVISION:	

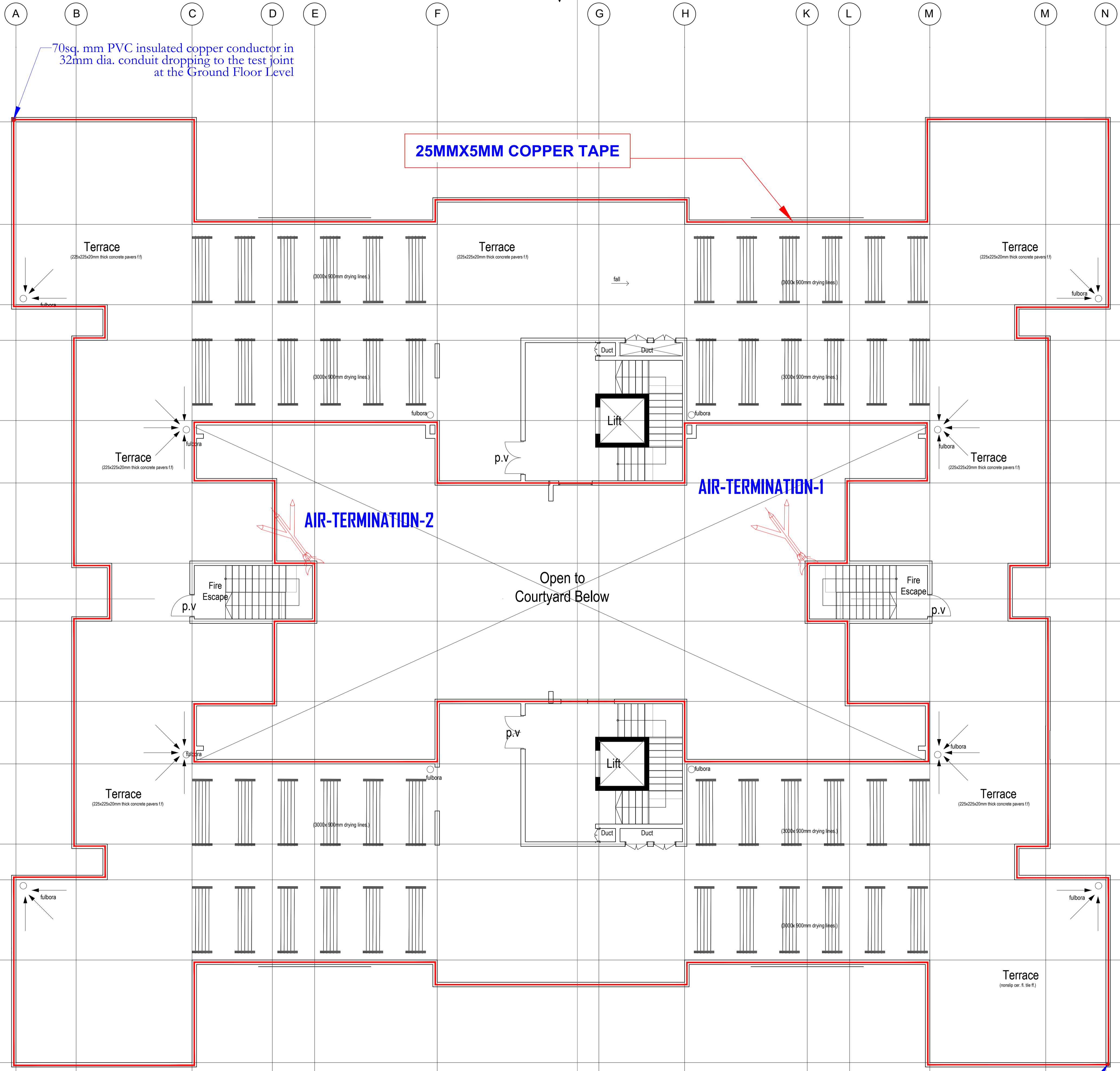

Notes:

1. THIS DRAWING IS TO BE READ WITH ALL OTHER DISCIPLINES, DRAWINGS, SCHEDULES AND SPECIFICATIONS, LEGEND AND STANDARD DETAILS.
2. THIS DRAWING IS A COPYRIGHT AND SHALL NOT BE REPRODUCED WITHOUT PERMISSION.
3. DIMENSIONS GOVERN ON ALL DRAWINGS AND DETAILS. SHOULD ANY DISCREPANCIES BE FOUND WITH THIS DRAWING AND ANY ASSOCIATED DRAWINGS, OR SPECIFICATIONS THIS SHOULD BE BROUGHT TO THE ATTENTION OF M&E BUILDING SERVICES CONSULTANT IMMEDIATELY.
4. UNLESS OTHERWISE STATED ALL DIMENSIONS ARE IN MILLIMETERS. DO NOT SCALE FROM THIS DRAWING.
5. DIMENSIONS TO BE CHECKED ON SITE BEFORE ANY WORKS IS PUT IN HAND OR PREFABRICATED.
6. THIS DRAWING SHOULD BE USED FOR THE SPECIFIC SERVICES INTENDED.
7. THIS DRAWING SHOWS THE DESIGN INTEND ONLY. THE CONTRACTOR SHALL BE RESPONSIBLE FOR FULL CO-ORDINATION OF THE SERVICES INDICATED ON THIS AND ALL OTHER SERVICES DRAWINGS.
8. FINAL ACCESS AND SETTING OUT OF SERVICES SHALL BE AGREED BETWEEN THE ARCHITECT AND THE CONTRACTOR.
9. THE PROJECT NOTES ARE TO BE READ IN CONJUNCTION WITH ALL RELEVANT TECHNICAL SPECIFICATIONS.

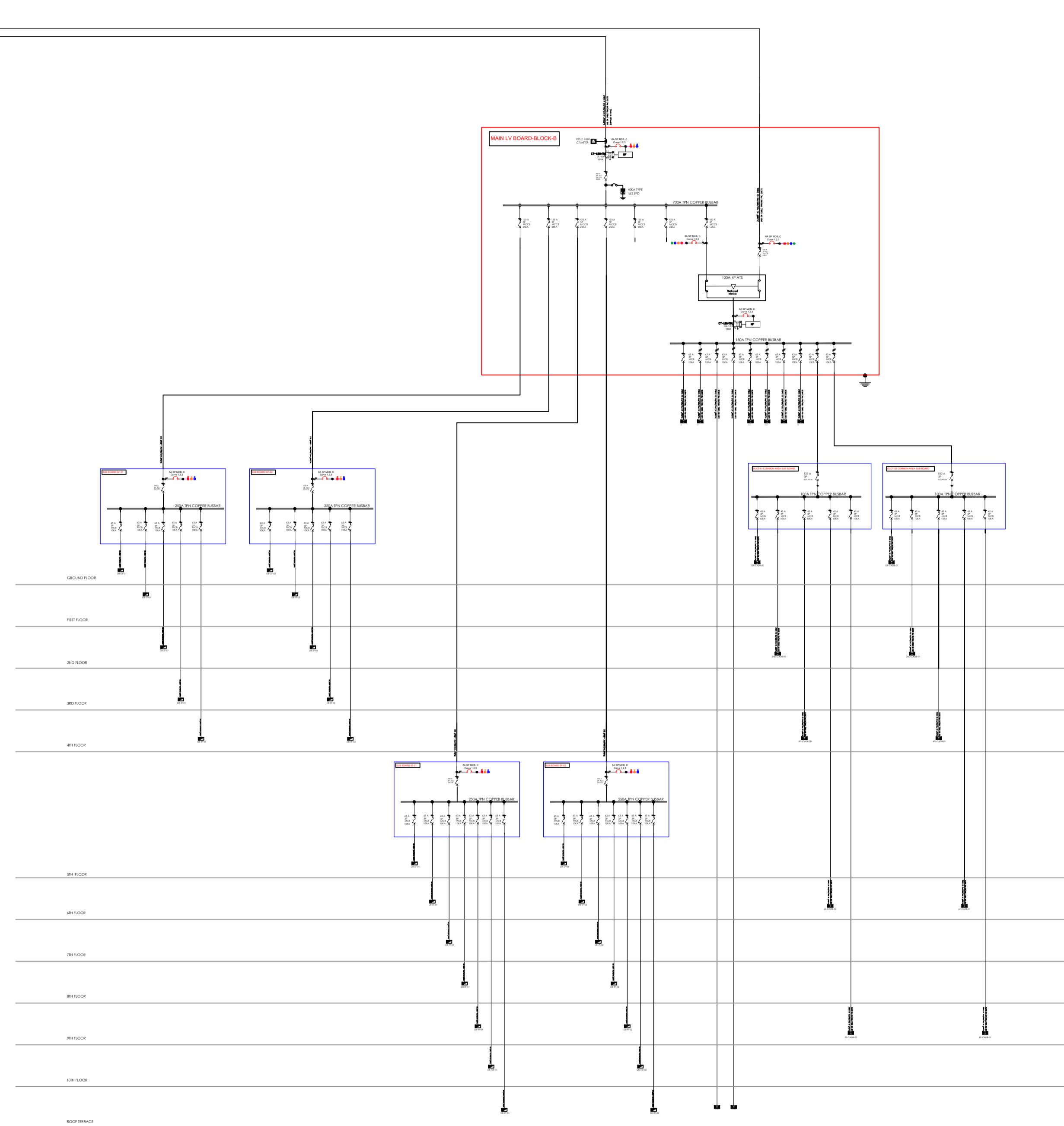
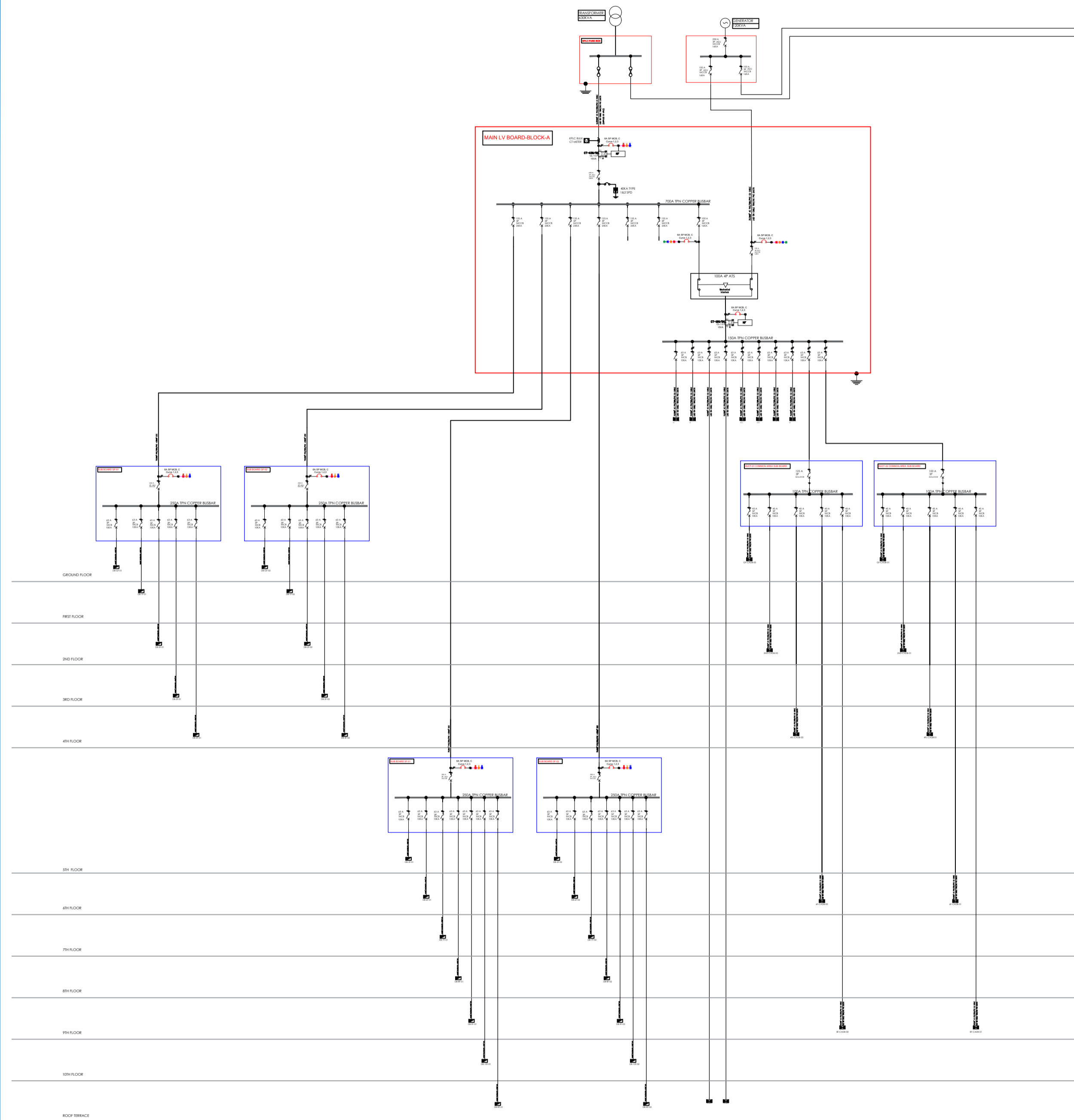

REV	CHANGES	BY:	DATE:

CLIENT:



STATE DEPARTMENT FOR HOUSING AND URBAN DEVELOPMENT

ARCHITECT:

STRUCTURAL:

QUANTITY SURVEYOR:

SITE: **ALUPE STUDENT HOUSING**

TITLE: **ELECTRICAL SCHEMATIC**

SCALE : NOT TO SCALE	DATE:	DRAWN:	CHECKED:
PROJECT NO:	DRAWING NO:	REVISION:	

MECHANICAL DRAWINGS

STUDENT HOUSING

E-28

E-26

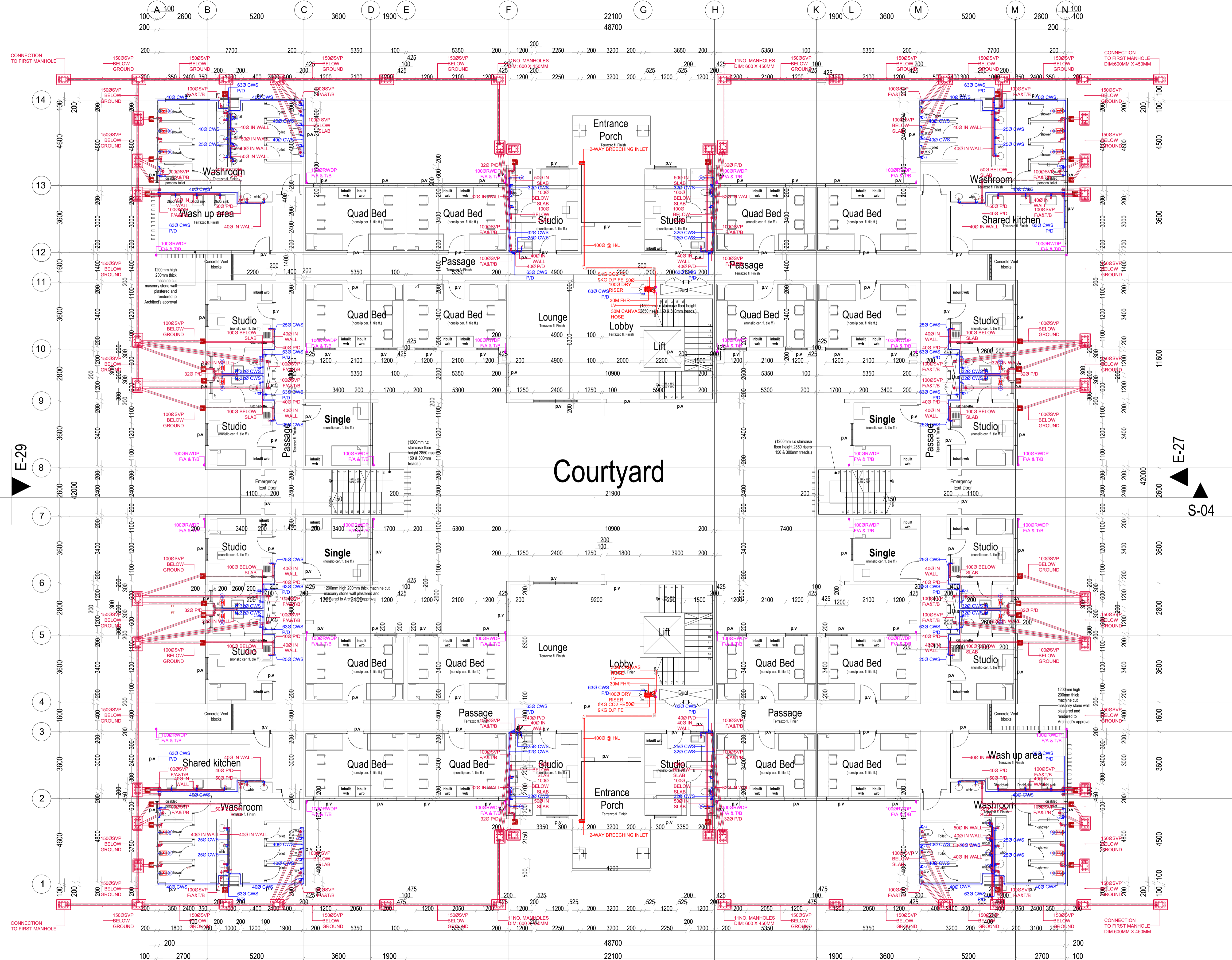

- Notes:**
1. THIS DRAWING IS TO BE READ WITH ALL OTHER DISCIPLINES, DRAWINGS, SCHEDULES AND SPECIFICATIONS AND STANDARD DETAILS.
 2. THIS DRAWING IS A COPYRIGHT AND SHALL NOT BE REPRODUCED WITHOUT PERMISSION.
 3. DIMENSIONS GIVEN ON ALL DRAWINGS AND DETAILS, SHOULD ANY DISCREPANCIES BE FOUND WITH THIS DRAWING AND ANY ASSOCIATED DRAWINGS, OR SPECIFICATIONS THIS SHOULD BE BROUGHT TO THE ATTENTION OF M&E BUILDING SERVICES CONSULTANT IMMEDIATELY. UNLESS OTHERWISE STATED, ALL DIMENSIONS ARE IN MILLIMETERS. DO NOT SCALE FROM THIS DRAWING.
 4. DIMENSIONS TO BE CHECKED ON SITE BEFORE ANY WORKS IS PUT IN HAND OR PRE-FABRICATED.
 5. THIS DRAWING SHOULD BE USED FOR THE SPECIFIC SERVICES INTENDED. THIS DRAWING SHOWS THE DESIGN INTEND ONLY. THE CONTRACTOR SHALL BE RESPONSIBLE FOR FULL CO-ORDINATION OF THE SERVICES INDICATED ON THIS AND ALL OTHER SERVICES DRAWINGS.
 6. FINAL ACCESS AND SETTING OUT OF SERVICES SHALL BE AGREED BETWEEN THE ARCHITECT AND THE CONTRACTOR.
 7. THE PROJECT NOTES ARE TO BE READ IN CONJUNCTION WITH ALL RELEVANT TECHNICAL SPECIFICATIONS.

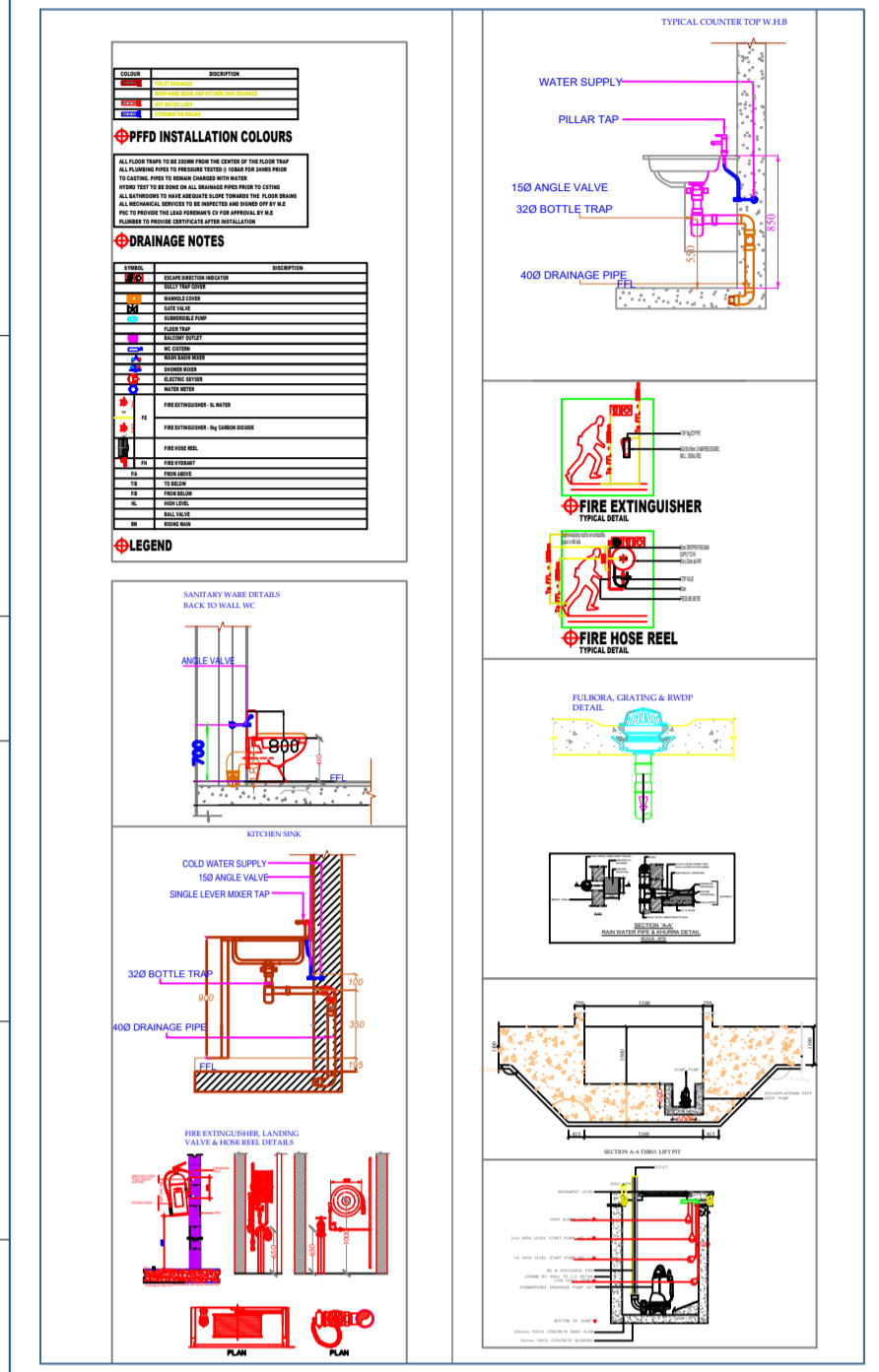

E-29

E-27

S-04

Courtyard

CLIENT: STATE DEPARTMENT FOR HOUSING AND URBAN DEVELOPMENT

ARCHITECT:

STRUCTURAL:

QUANTITY SURVEYOR:

SITE: ALUPE STUDENT HOUSING

TITLE: GROUND FLOOR PLUMBING DRAINAGE & FIRE FIGHTING LAYOUT

SCALE: NOT TO SCALE

DATE:

DRAWN:

CHECKED:

PROJECT NO:

DRAWING NO:

REVISION:

E-28

E-26

E-29

E-27

S-04

Courtyard

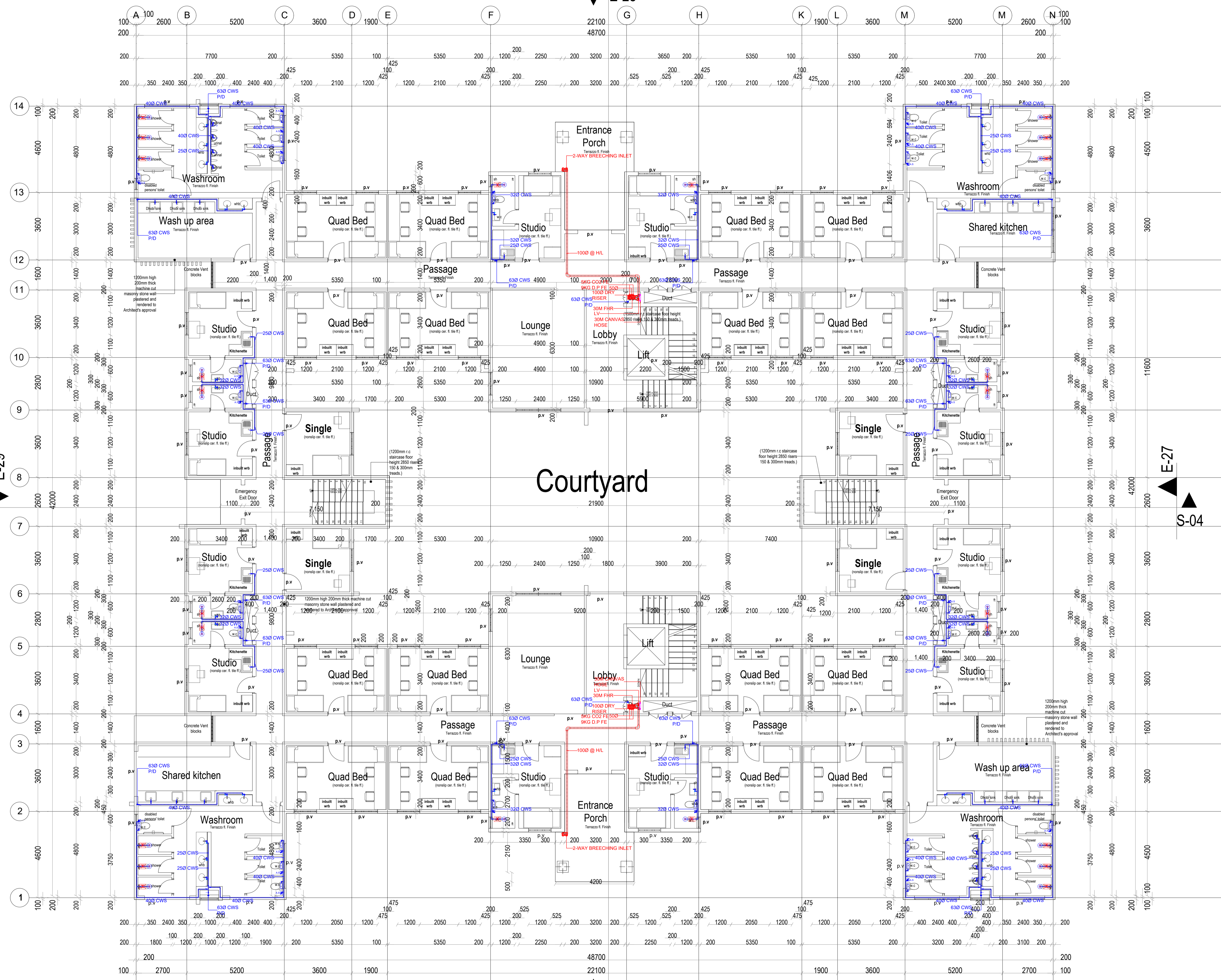

Notes:

1. THIS DRAWING IS TO BE READ WITH ALL OTHER DISCIPLINES, DRAWINGS, SCHEDULES AND SPECIFICATIONS LEGEND AND STANDARD DETAILS.
2. THIS DRAWING IS A COPYRIGHT AND SHALL NOT BE REPRODUCED WITHOUT PERMISSION.
3. DIMENSIONS GIVEN ON ALL DRAWINGS AND DETAILS, SHOULD ANY DISCREPANCIES BE FOUND WITH THIS DRAWING AND ANY ASSOCIATED DRAWINGS, OR SPECIFICATIONS THIS SHOULD BE BROUGHT TO THE ATTENTION OF M&E BUILDING SERVICES CONSULTANT IMMEDIATELY, UNLESS OTHERWISE STATED. ALL DIMENSIONS ARE IN MILLIMETERS. DO NOT SCALE FROM THIS DRAWING.
4. DIMENSIONS TO BE CHECKED ON SITE BEFORE ANY WORKS IS PUT IN HAND OR PREFABRICATED.
5. THIS DRAWING SHOULD BE USED FOR THE SPECIFIC SERVICES INTENDED.
6. THE DRAWING SHOWS THE DESIGN INTEND ONLY. THE CONTRACTOR SHALL BE RESPONSIBLE FOR FULL CO-ORDINATION OF THE SERVICES INDICATED ON THIS AND ALL OTHER SERVICES DRAWINGS.
7. FINAL ACCESS AND SETTING OUT OF SERVICES SHALL BE AGREED BETWEEN THE ARCHITECT AND THE CONTRACTOR.
8. THE PROJECT NOTES ARE TO BE READ IN CONJUNCTION WITH ALL RELEVANT TECHNICAL SPECIFICATIONS.

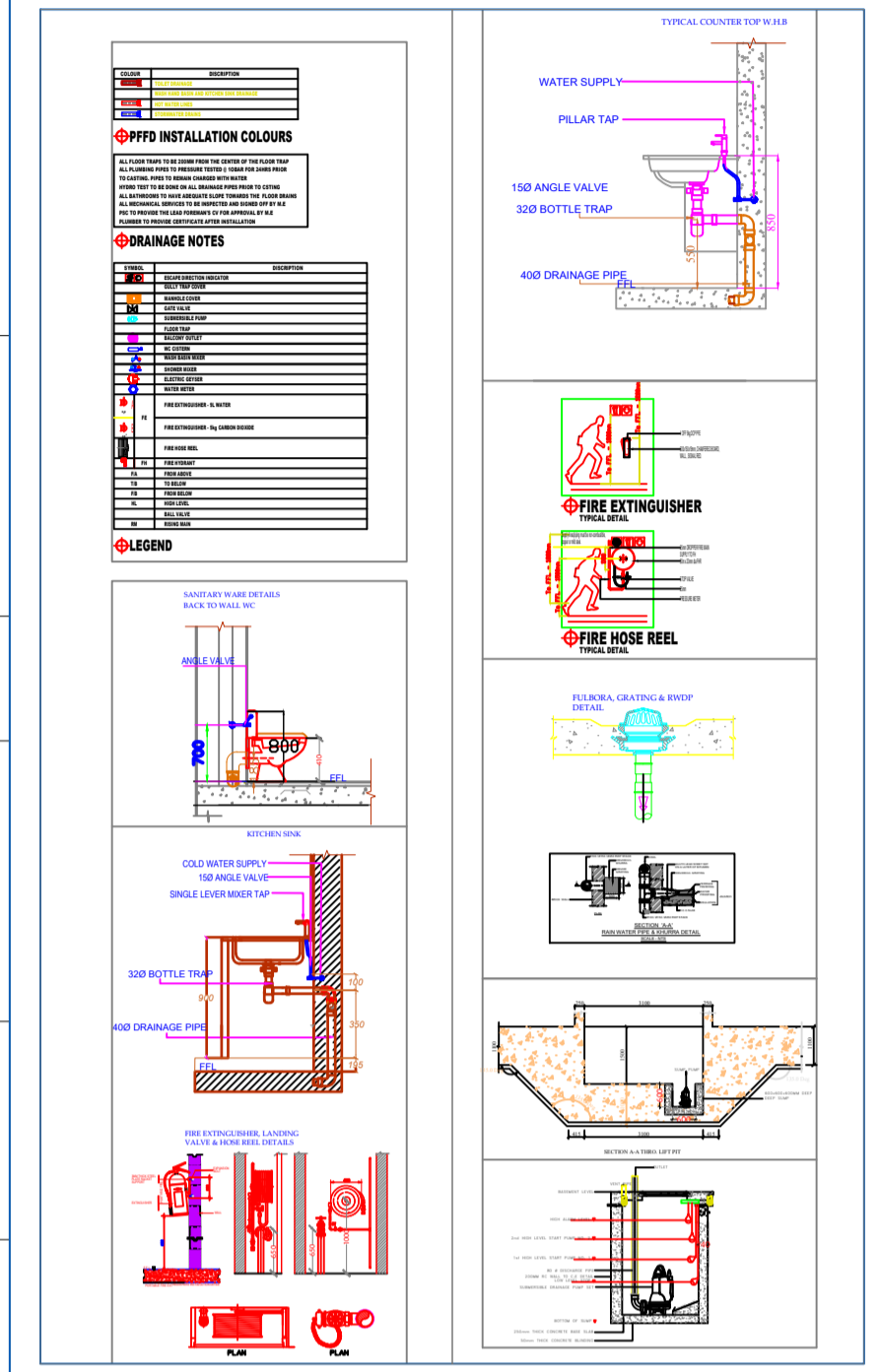

CLIENT:  STATE DEPARTMENT FOR HOUSING AND URBAN DEVELOPMENT

ARCHITECT:

STRUCTURAL:

QUANTITY SURVEYOR:

SITE: **ALUPE STUDENT HOUSING**

TITLE: **GROUND FLOOR PLUMBING & FIRE FIGHTING LAYOUT**

SCALE: **NOT TO SCALE**

DATE:	DRAWN:	CHECKED:
PROJECT NO:	DRAWING NO:	REVISION:

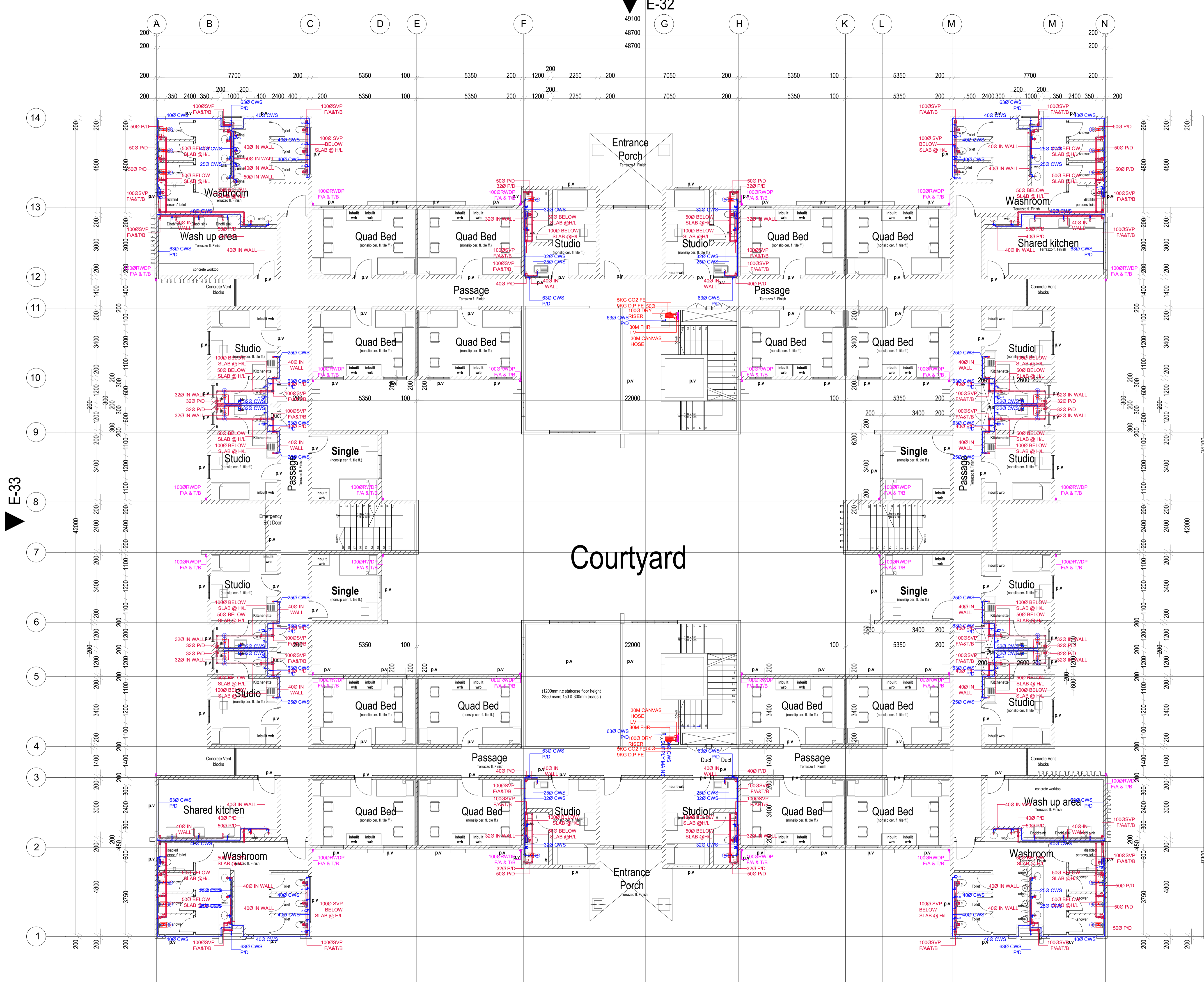

- Notes:**
- THIS DRAWING IS TO BE READ WITH ALL OTHER DISCIPLINES, DRAWINGS, SCHEDULES AND SPECIFICATIONS LEGEND AND STANDARD DETAILS.
 - THIS DRAWING IS A COPYRIGHT AND SHALL NOT BE REPRODUCED WITHOUT PERMISSION.
 - DIMENSIONS GIVEN ON ALL DRAWINGS AND DETAILS SHOULD ANY DISCREPANCIES BE FOUND WITH THIS DRAWING AND ANY ASSOCIATED DRAWINGS, OR SPECIFICATIONS THIS SHOULD BE BROUGHT TO THE ATTENTION OF M&E BUILDING SERVICES CONSULTANT IMMEDIATELY, UNLESS OTHERWISE STATED. ALL DIMENSIONS ARE IN MILLIMETERS. DO NOT SCALE FROM THIS DRAWING.
 - DIMENSIONS TO BE CHECKED ON SITE BEFORE ANY WORKS IS PUT IN HAND OR PRE-FABRICATED.
 - THIS DRAWING SHOULD BE USED FOR THE SPECIFIC SERVICES INTENDED.
 - THE CONTRACTOR SHALL BE RESPONSIBLE FOR FULL CO-ORDINATION OF THE SERVICES INDICATED ON THIS AND ALL OTHER SERVICES DRAWINGS.
 - FINAL ACCESS AND SETTING OUT OF SERVICES SHALL BE AGREED BETWEEN THE ARCHITECT AND THE CONTRACTOR.
 - THE PROJECT NOTES ARE TO BE READ IN CONJUNCTION WITH ALL RELEVANT TECHNICAL SPECIFICATIONS.

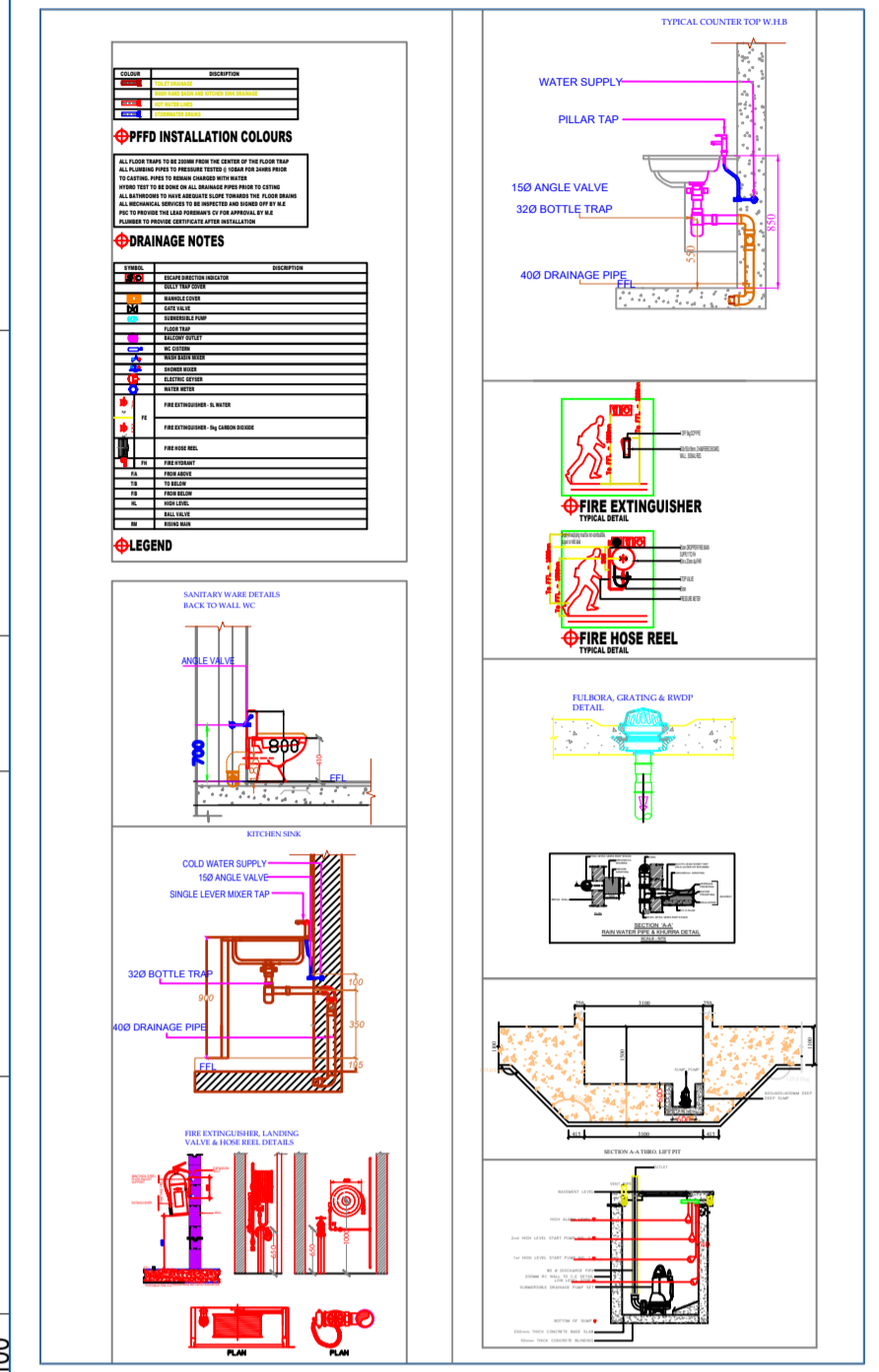

Courtyard

CLIENT:  STATE DEPARTMENT FOR HOUSING AND URBAN DEVELOPMENT

ARCHITECT:

STRUCTURAL:

QUANTITY SURVEYOR:

SITE: ALUPE STUDENT HOUSING

TITLE: FIRST FLOOR PLUMBING DRAINAGE & FIRE FIGHTING LAYOUT

SCALE: NOT TO SCALE	DATE:	DRAWN:	CHECKED:
PROJECT NO:	DRAWING NO:	REVISION:	

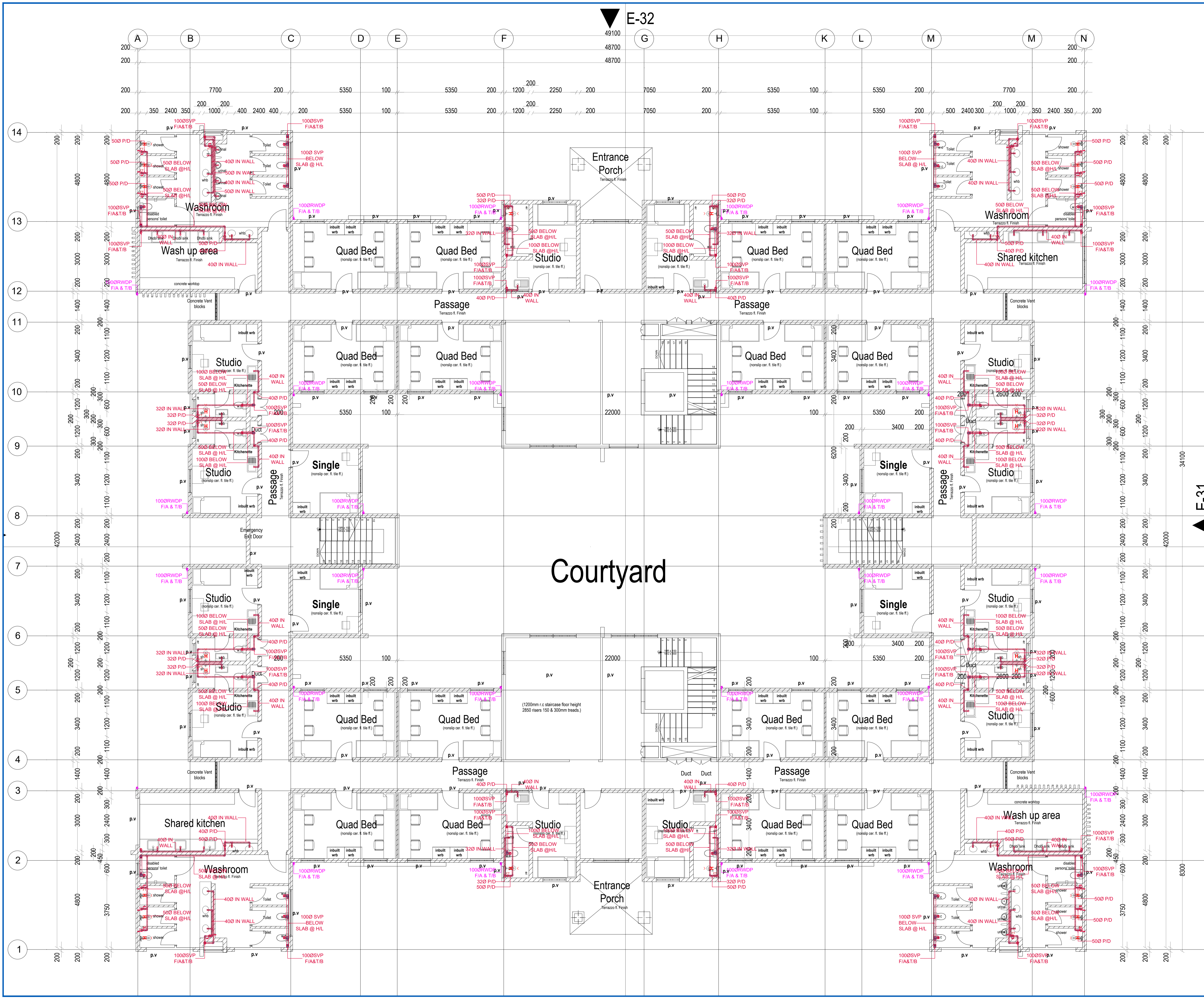

- Notes:**
- THIS DRAWING IS TO BE READ WITH ALL OTHER DISCIPLINES, DRAWINGS, SCHEDULES AND SPECIFICATIONS/LEGEND AND STANDARD DETAILS.
 - THIS DRAWING IS A COPYRIGHT AND SHALL NOT BE REPRODUCED WITHOUT PERMISSION.
 - DIMENSIONS GIVEN ON ALL DRAWINGS AND DETAILS, SHOULD ANY DISCREPANCIES BE FOUND WITH THIS DRAWING AND ANY ASSOCIATED DRAWINGS, OR SPECIFICATIONS THIS SHOULD BE BROUGHT TO THE ATTENTION OF M&E BUILDING SERVICES CONSULTANT IMMEDIATELY, UNLESS OTHERWISE STATED. ALL DIMENSIONS ARE IN MILLIMETERS. DO NOT SCALE FROM THIS DRAWING.
 - DIMENSIONS TO BE CHECKED ON SITE BEFORE ANY WORKS IS PUT IN HAND OR PRE-FABRICATED.
 - THIS DRAWING SHOULD BE USED FOR THE SPECIFIC SERVICES INTENDED. THE DRAWING SHOWS THE DESIGN INTEND ONLY. THE CONTRACTOR SHALL BE RESPONSIBLE FOR FULL CO-ORDINATION OF THE SERVICES INDICATED ON THIS AND ALL OTHER SERVICES DRAWINGS.
 - FINAL ACCESS AND SETTING OUT OF SERVICES SHALL BE AGREED BETWEEN THE ARCHITECT AND THE CONTRACTOR.
 - THE PROJECT NOTES ARE TO BE READ IN CONJUNCTION WITH ALL RELEVANT TECHNICAL SPECIFICATIONS.

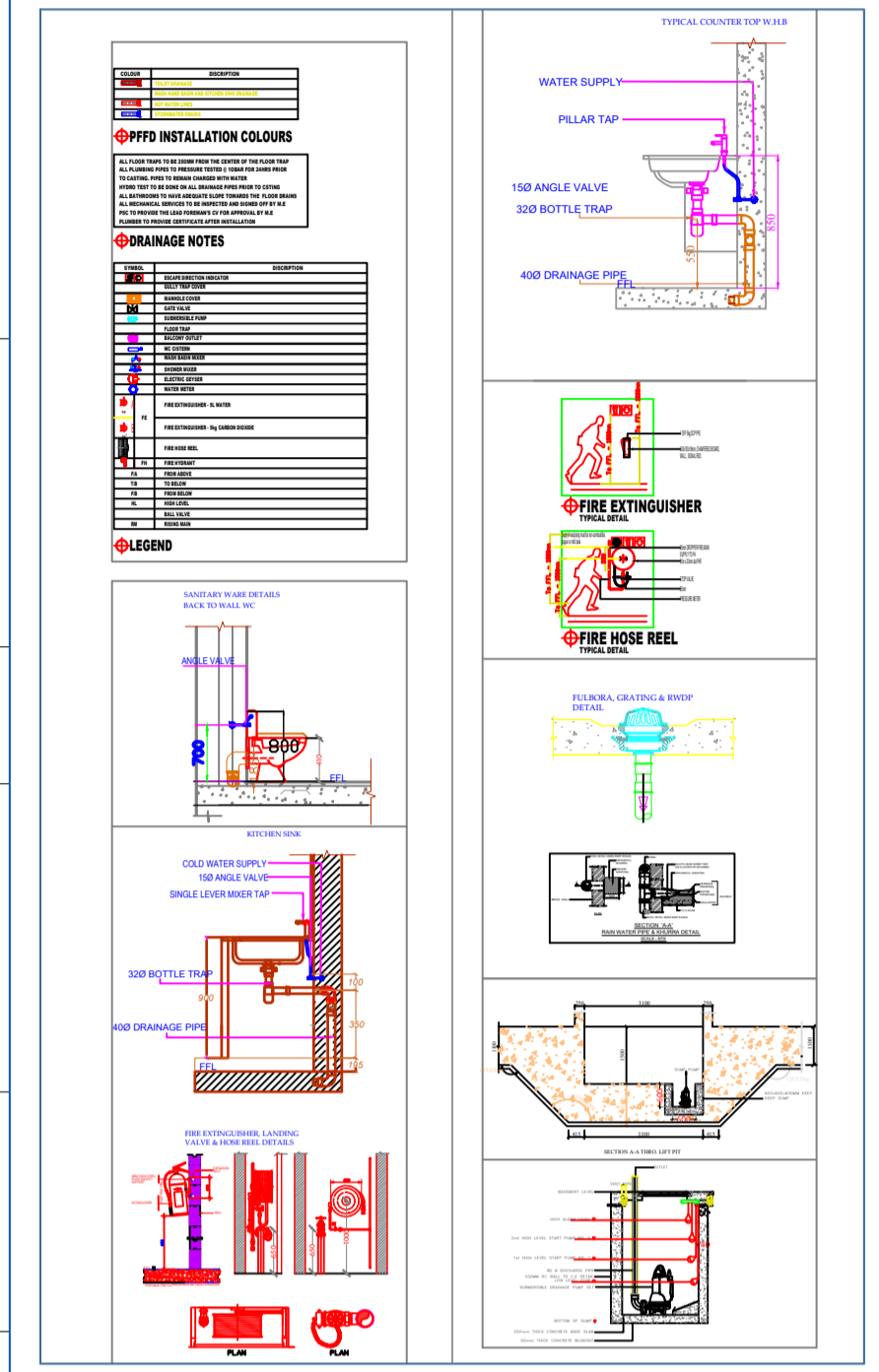

CLIENT: STATE DEPARTMENT FOR HOUSING AND URBAN DEVELOPMENT

ARCHITECT:

STRUCTURAL:

QUANTITY SURVEYOR:

SITE: ALUPE STUDENT HOUSING

TITLE: FIRST FLOOR DRAINAGE LAYOUT

SCALE: NOT TO SCALE	DATE:	DRAWN:	CHECKED:
PROJECT NO:	DRAWING NO:		REVISION:

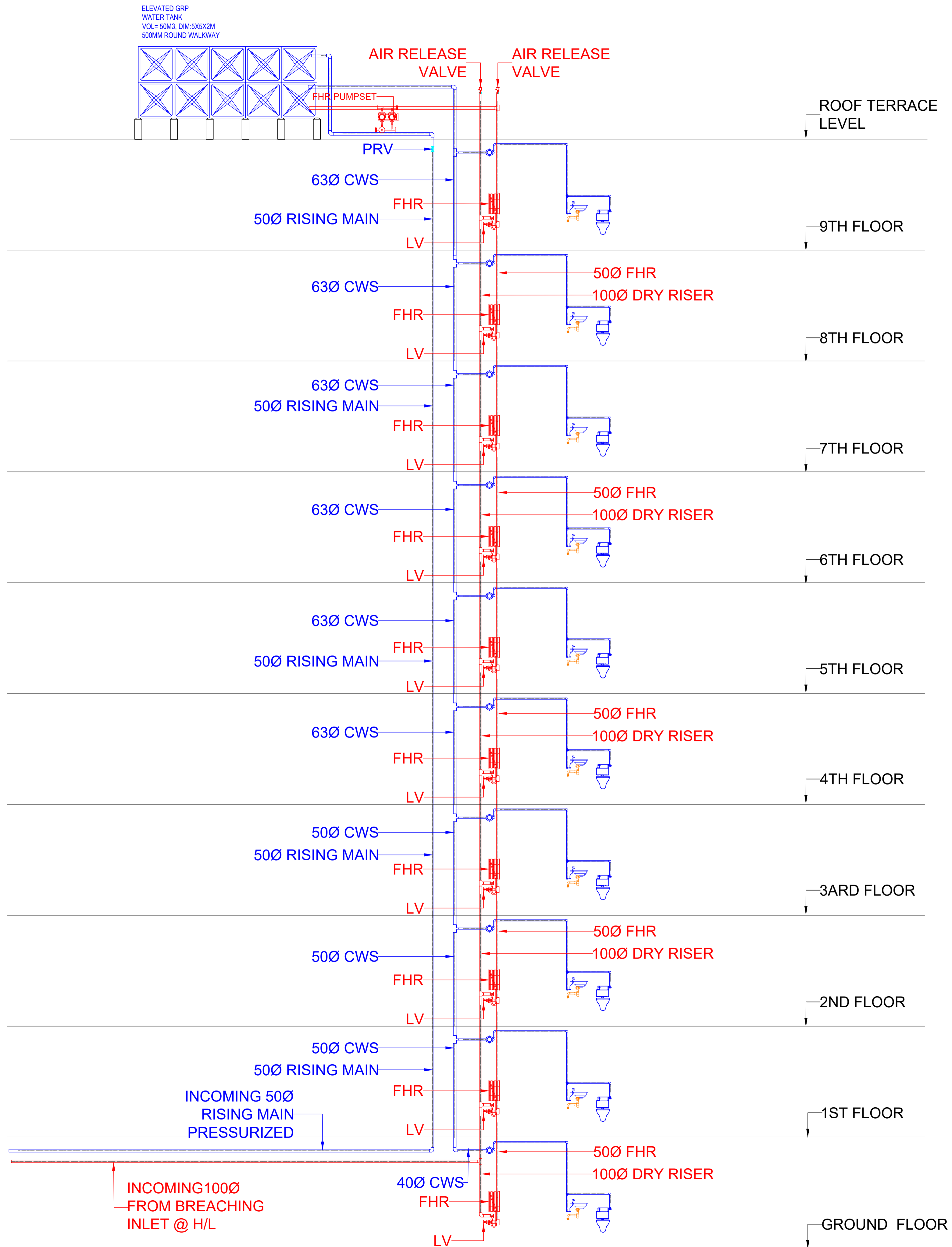

Notes:

1. THIS DRAWING IS TO BE READ WITH ALL OTHER DISCIPLINES, DRAWINGS, SCHEDULES AND SPECIFICATIONS, LEGEND AND STANDARD DETAILS.
2. THIS DRAWING IS A COPYRIGHT AND SHALL NOT BE REPRODUCED WITHOUT PERMISSION.
3. DIMENSIONS GIVEN ON ALL DRAWINGS AND DETAILS, SHOULD ANY DISCREPANCIES BE FOUND WITH THIS DRAWING AND ANY ASSOCIATED DRAWINGS, OR SPECIFICATIONS THIS SHOULD BE BROUGHT TO THE ATTENTION OF M&E BUILDING SERVICES CONSULTANT IMMEDIATELY. UNLESS OTHERWISE STATED ALL DIMENSIONS ARE IN MILLIMETERS. DO NOT SCALE FROM THIS DRAWING.
4. DIMENSIONS TO BE CHECKED ON SITE BEFORE ANY WORKS IS PUT IN HAND OR PREFABRICATED.
5. THIS DRAWING SHOULD BE USED FOR THE SPECIFIC SERVICES INTENDED.
6. THE CONTRACTOR SHALL BE RESPONSIBLE FOR FULL CO-ORDINATION OF THE SERVICES INDICATED ON THIS AND ALL OTHER SERVICES DRAWINGS.
7. FINAL ACCESS AND SETTING OUT OF SERVICES SHALL BE AGREED BETWEEN THE ARCHITECT AND THE CONTRACTOR.
8. THE PROJECT NOTES ARE TO BE READ IN CONJUNCTION WITH ALL RELEVANT TECHNICAL SPECIFICATIONS.

<p>PPFR INSTALLATION COLOURS</p>	<p>ORANGE NOTES</p>	<p>WATER SUPPLY</p>
<p>LEGEND</p>	<p>FIRE EXTINGUISHER</p>	<p>FIRE HOSE REEL</p>
<p>CO2 WATER SUPPLY</p>	<p>LEGEND</p>	<p>LEGEND</p>

CLIENT: STATE DEPARTMENT FOR HOUSING AND URBAN DEVELOPMENT

ARCHITECT:

STRUCTURAL:

QUANTITY SURVEYOR:

SITE: **ALUPE STUDENT HOUSING**

TITLE: **PLUMBING & FIRE FIGHTING TYPICAL BLOCK SCHEMATIC**

SCALE : NOT TO SCALE	DATE:	DRAWN:	CHECKED:
PROJECT NO:	DRAWING NO:	REVISION:	