

**PROJECT DATA SHEET**

**PROJECT : PROPOSED BUNGOMA SMART CITY AFFORDABLE HOUSING  
AND MIXED-USE DEVELOPMENT IN BUNGOMA TOWN, BUNGOMA  
COUNTY**

Item	DETAILS OF SITE	PROJECT PARTICULARS
1	<b>Tender No</b>	MLPWHUD/SDHUD/AHP/341/2023-2024
2	<b>Site location</b>	Bungoma Town, Bungoma County
3	<b>Land Size</b>	Approximately 21.24 Acres
4	<b>Scope</b>	<p>1639 No. of Units in 9No of blocks Type A &amp; 8 No block Type B distributed as follows</p> <p>1 Room Social Housing : 90 Units            2 Room Social Housing : 180 Units            3 Room Social Housing : 90 Units</p> <p>Studio Apt Affordable Housing : 189 Units            2Br Apt Affordable Housing : 440 Units            3Br Apt Affordable Housing : 170 Units</p> <p>2Br Apt Market Housing : 240 Units            3Br Apt Market Housing : 240 Units</p>
5	<b>Amenities</b>	Market, Club House, Primary School, Social Halls, Guard House, Garbage Receptacles,
6	<b>External works</b>	Civil works, Boundary wall, Landscaping, Soccer Field, Basketball Court,
7	<b>Built area</b>	113,150 Sqm

**REPUBLIC OF KENYA**



**MINISTRY OF LANDS, PUBLIC WORKS, HOUSING AND URBAN DEVELOPMENT**

**STATE DEPARTMENT OF HOUSING AND URBAN DEVELOPMENT**

**BILL OF QUANTITIES**

**FOR:**

**PROPOSED CONSTRUCT + FINANCE OF BUNGOMA SMART CITY AFFORDABLE HOUSING & MIXED USE DEVELOPMENT AND ASSOCIATED INFRASTRUCTURE IN BUNGOMA TOWN BUNGOMA COUNTY**

Ministry of Lands, Public Works, Housing and Urban Development

State Department for Housing and Urban Development,

P.O Box 30119-00100 Nairobi,

Kenya Tel: +254-020-2713833

# **GENERAL SPECIFICATIONS**

## **SPECIFICATIONS**

Reference is made to the General Specifications for Building Works (1976) by the Ministry of Works, Housing and Physical Planning.

A copy is available for perusing at the request of the procuring entity.

Contractors are required to adhere to the latest industry standards as outlined in the most recent version of KS (Kenyan Standards) / BS (British Standards) EN International standards. Failure to comply may result in project delays or financial penalties. It is the responsibility of the Contractor to stay informed about and apply the current industry standards throughout the construction process. Any disputes arising from non-compliance with updated standards will be subject to resolution through dispute resolution mechanism outlined in the contract.

# **PRELIMINARIES**

ITEM	DESCRIPTION	AMOUNT
A	<p><b><u>BILL NO. 1</u></b></p> <p><b><u>PARTICULAR PRELIMINARIES</u></b></p> <p><b><u>PARTIES</u></b></p> <p>The <b>Employer</b> is:</p> <p>Principal Secretary, Ministry of Lands, Public works,Housing and Urban Development, State Department of Housing and Urban Development P.O Box 30119 -00100 NAIROBI, KENYA</p> <p>The <b>Engineer</b> is: The term "PM" wherever used in these Bills of Quantities shall be deemed to imply the Engineer as defined in Condition 1 of the Conditions of Contract or such person or persons as may be duly authorised to represent him on behalf of the Government .</p> <p><b>The Architect is:</b> Ministry of Lands, Public works,Housing and Urban Development, State Department of Housing and Urban Development P.O Box 30119 -00100 NAIROBI, KENYA</p> <p><b>The Quantity Surveyors is:</b> Ministry of Lands, Public works,Housing and Urban Development, State Department of Housing and Urban Development P.O Box 30119 -00100 NAIROBI, KENYA</p> <p><b>The Structural/ Civil Engineers is:</b> Ministry of Lands, Public works,Housing and Urban Development, State Department of Housing and Urban Development P.O Box 30119 -00100 NAIROBI, KENYA</p> <p><b>The Electrical / Mechanical Engineers is:</b> Ministry of Lands, Public works,Housing and Urban Development, State Department of Housing and Urban Development P.O Box 30119 -00100 NAIROBI, KENYA</p>	

ITEM	DESCRIPTION	AMOUNT
A	<p><b><u>LOCATION OF SITE</u></b></p> <p>The site of the proposed works is located in <b>Bungoma Town , Bungoma County</b></p> <p>The Contractor shall be deemed to have visited the site and satisfied himself as to:-</p> <p>a) The nature, position, topography and access of the site  b) The amount of the rubbish or debris to be cleared away before commencement.  c) The nature, current usage, proximity and size of adjoining property and buildings  d) The availability of land for the erection and positioning of all temporary structures, plant and materials necessary for the execution of the works.</p> <p>The Contractor shall obtain approval from the relevant Local Authority in adherence to site access and erection of temporary structures and must ensure all matters relating to the requirements of these authorities.</p> <p>No claim will be allowed for travelling or other expenses which may be incurred by the Contractor in visiting the site or preparing the tender for the works.</p>	
B	<p><b><u>EXISTING SITE CONDITIONS</u></b></p> <p>The Contractor is advised that the site is in a predominantly residential area and all measures should be taken to avoid nuisance to neighbours.</p> <p>All occupation health and safety requirements must be met as required by law.</p> <p>This includes prevention and or minimizing noise, dust, fumes e.t.c.</p> <p>Notices should be given prior to disruption of services</p>	
C	<p><b><u>SCOPE OF CONTRACT</u></b></p> <p>The Works under this contract comprises of the structures as detailed in the project data sheet</p>	
	Carried to collection	

ITEM	DESCRIPTION	AMOUNT
A	<p><b><u>DESCRIPTION OF THE WORKS</u></b></p> <p>The construction comprises reinforced concrete foundations, masonry walling, reinforced concrete beams, column , staircases and suspended solid slabs, roof construction.</p> <p>The exterior facade consists of steel casement windows, steel and timber doors , render and paint finish, clay and stone facing finish to walls</p> <p>The interior works includes timber doors and finishes which are generally plaster and paint to walls, ceramic and non slip ceramic tiles to floors and walls.</p> <p>External works generally comprise of foul water drainage, storm water drainage, pathway, dryline area, septic tank, underground water tank.</p> <p>All mechanical / electrical services and other specialist works associated with the above works shall be executed by domestic/nominated sub contractors approved by the Engineer</p> <p><b><u>CONTRACT PARTICULARS</u></b></p> <p><b>B <u>FORM OF CONTRACT</u></b></p> <p>The Contractor will be required to enter into a contract with the Employer under the <b>Terms and Conditions of Contract as "Standard Tender Document for Procurement of Works (Building and Associated Civil Engineering Works) Issued by the Public Procurement Regulatory Authority in February 2021 (updated 2022)</b> and in association with the latest applicable version of the Public Procurement and Asset Disposal Act.</p> <p>The Contractor's attention is called to the appendix of the conditions of Contract and additions and amendments thereto, which shall be read as incorporated herein and he shall allow any sums which he considers necessary for the observance of such conditions, together with sub clauses used in application.</p> <p>The priority of such documents shall be as stated in the conditions of agreement.</p> <p><b>Carried to collection</b></p>	



ITEM	DESCRIPTION	AMOUNT
A	<p><b><u>LIABILITY AGAINST INJURY TO PERSONS AND PROPERTY</u></b></p> <p>Insurance against injury to persons and property</p> <p>NOTES In addition to the conditions of the contract and the requirement contained herein the contractor's all risk policy shall cover the full value of the following and allow for all costs thereof:-</p> <ul style="list-style-type: none"> <li>i) The works and temporary works erected in performance of this contract.</li> <li>ii) The materials on site, plant and tools</li> <li>iii) The cost and expense of removing debris of the property insured, destroyed or damaged by any peril insured.</li> <li>iv) Professional fees (to be allowed at 15% of the contract sum)</li> <li>v) Employer's liability (workman's compensation)</li> <li>ii) Third party (Public liability for an indemnity of not less than shs 15,000,000 for any accident or series of accidents arising from the same event (unlimited in aggregate)</li> </ul> <p>The contractor shall ensure that all sub-contractors effect and maintain such insurances as are necessary to cover their liabilities in respect of injury to persons and property and workman,s compensation.</p> <p>Should the contractor already hold annual insurances covering the whole of his activities, and the indemnity required under the existing policy/ies then further insurances shall be effected and maintained to cover such excess, the policies of insurances being suitably endorsed to cover this project</p>	
B	<p><b><u>Insurance of the works (contractors liability)</u></b></p> <p>The Contractor shall insure as required in the Conditions of Contract. No payment on account of the work executed will be made to the Contractor until he has satisfied the Engineer either by production of an Insurance Policy or and Insurance Certificate that the provision of the foregoing Insurance Clauses have been complied with in all respects.</p> <p>Thereafter the Engineer shall from time to time ascertain that premiums are duly paid up by the Contractor who shall if called upon to do so, produce the receipted premium renewals for the Engineer's inspection.</p> <p><b>Carried to collection</b></p>	

ITEM	DESCRIPTION	AMOUNT
A	<p><b><u>PERFORMANCE BOND</u></b></p> <p><b>Performance bond for the works</b></p> <p>The Contractor shall submit on the Form of Tender an approved bank or approved (By PPRA) Insurance Company and who will be willing to be bound to the Employer in an amount .....(<i>as defined in the bidding documents</i>)..... for the due performances of the Contract up to the date of completion as certified by the Engineer and who will when and if called upon, sign a Bond to that effect on the relevant standard form as seen in the CONTRACT STANDARD FORMS (without the addition of any limitations)</p> <p>And should the surety fail to be approved, the Contractor shall furnish within seven days another Surety to the approval of the Employer.</p> <p>Note that no payments on account of works executed will be made to the Contractor until he has submitted the Performance bond, duly stamped signed and sealed by an approved bank or insurance company.</p>	
B	<p><b><u>POSSESSION AND COMMENCEMENT</u></b></p> <p>The Contractor shall take possession of the site on the date indicated in the acceptance letter. The date of commencement of the works shall also be communicated to the Contractor and the contract period shall run from the commencement date.</p> <p>The Contractor is expected to utilize the period between possession and commencement to mobilise his resources to ensure smooth running of the works from the commencement date.</p> <p><b>Carried to collection</b></p>	



ITEM	DESCRIPTION	AMOUNT
	<u>BILL NO. 1</u>	
	<u>PARTICULAR PRELIMINARIES</u>	
	<u>COLLECTION</u>	
	Carried from page 1/1	
	Carried from page 1/2	
	Carried from page 1/3	
	Carried from page 1/4	
	Carried from page 1/5	
	Carried from page 1/6	
	<b>Particular Preliminaries Carried to Summary of Bill No. 1</b>	

ITEM	DESCRIPTION	AMOUNT
	<p><b><u>BILL NO. 2</u></b></p> <p><b><u>GENERAL PRELIMINARIES</u></b></p> <p><b><u>PRICING OF ITEMS OF PRELIMINARIES AND PREAMBLES</u></b></p> <p><b>A</b> Whenever in the Contractor's priced Bills of Quantities no price appears against an item of Preliminaries or Preambles or work items , the value of such item shall be deemed to be included in his prices for other items in the Bills of Quantities.</p> <p><b><u>SUFFICIENCY OF TENDER</u></b></p> <p><b>B</b> The Contractor shall be deemed to have satisfied himself before tendering as to the correctness and sufficiency of his tender for the works and of the rates and prices stated in the priced Bills of Quantities. Rates and prices quoted shall cover all his obligations under the contract and all the matters and maintenance of the works</p> <p><b><u>RECORDS</u></b></p> <p><b>C</b> The Contractor shall ensure proper records are kept and maintained for : Daily Reports on Personnel and Machinery; tracked programme; weather charts/reports; site instruction book and query book,a digital camera shall be provided for taking progress photos</p> <p>The contractor shall be required to provide equipment for taking ground and aerial photos or videos in relation to the progress of works when called upon to do so.</p> <p><b><u>DEFINITIONS AND ABBREVIATIONS</u></b></p> <p><b>D</b> Throughout these Bills, units of measurements and terms are abbreviated and shall be interpreted as follows:</p> <p>mm shall mean millimeter</p> <p>lm shall mean linear meter</p> <p>sm shall mean square meter</p> <p>m<sup>2</sup> shall mean square meter</p> <p>cm shall mean cubic meter</p> <p>kg shall mean kilogramme</p> <p>N shall mean Newton</p> <p>KN shall mean KiloNewton</p> <p><b>Carried to collection</b></p>	



ITEM	DESCRIPTION	AMOUNT
	<p><b><u>SITE LEVELS</u></b></p> <p><b>A</b> Before commencing work the Contractor must arrange for and agree with the Architect, Engineer and Quantity Surveyor the existing site levels and similarly establish and agree on a bench mark.</p> <p>The Contractor shall provide a surveyor to ensure all levels are achieved as per the drawings and Architects/Structural Engineer's instructions</p> <p><b><u>SETTING OUT</u></b></p> <p><b>B</b> The contractor shall set out works in accordance with the dimensions and levels shown on the drawings and shall be responsible for the correctness of all dimensions and levels set out by him and he will be required to amend all errors arising from inaccurate setting out at his own cost and expenses. In the event of any error or discrepancy in the dimensions or levels marked on the drawings being discovered, such errors or discrepancies must be reported by the Contractor to the Engineer for his immediate attention.</p> <p>No work shall be commenced by the Contractor until he has received written instructions from the Engineer to adjust such discrepancies which may be proved, upon receipt of such instructions and no claim for extra expenses or relief from the provisions of Clause 5 of the Conditions of the Contract , any discrepancy or error in the dimensions or levels shown on the drawings may be made thereafter.</p> <p>The Contractor shall give the Engineer reasonable notice of the intention to set out or take levels for any part of the Works so that arrangements may be made for checking the work. The accuracy of setting out and leveling shall be within the tolerances specified in the Specifications or on the Drawings. The checking of setting out or leveling by the Engineer shall not relieve the Contractor of his duties or responsibilities under the Contract.</p> <p><b><u>MEASUREMENTS</u></b></p> <p><b>C</b> Measurements are based on <b>Standard Methods of Measurement of Building Works and Associated Civil Works For Eastern Africa (SMM) Second Edition 2008.</b></p> <p>In the event of any discrepancies arising between the Bills of Quantities and the actual works, the site measurements shall generally take precedence.</p> <p><b>D</b> <b><u>GENERAL SPECIFICATIONS</u></b></p> <p>All works to be carried out in accordance with the Ministry of Roads, public Works and Housing <b>General Specifications for Building Works issued in 1976</b> or as qualified and amended.</p> <p><b>Carried to collection</b></p>	

ITEM	DESCRIPTION	AMOUNT
	<p><b><u>SAMPLES</u></b></p> <p><b>A</b> The contractor shall furnish at the earliest possible opportunity before work commences and at his own cost any samples of materials or workmanship that may be called for by the Engineer for his approval or rejection until such samples are approved to be the acceptable standard for the work to which they apply.</p> <p>The samples shall be maintained and displayed on a designated section within the site for the duration of the project where practical and possible.</p> <p><b><u>PROTECTION OF EXISTING PROPERTY</u></b></p> <p><b>B</b> The contractor shall take every precaution to avoid damage to all existing property including boundary wall, carpark, roads, cables, drains, staircases, lift etc including other services and he will be held responsible for all damages hereto arising from the execution of his contract and he shall make good all such damages when directed at his own expense.</p> <p>Any damage or disturbances caused to any element shall be reported immediately to the Engineer and the relevant Authority and shall be made good to their satisfaction at the Contractor's expense.</p> <p><b>C <u>PROTECTION / RELOCATION OF EXISTING SERVICES</u></b></p> <p>Prior to commencement of any work the Contractor is to ascertain from the relevant Authorities the exact position, depth and level of all existing electric cables, water pipes and all other services in the area and he shall make whatever provisions may be required by the authorities concerned for the support and protection and/or relocation of such services as will be necessitated.</p> <p>The contractor is also expected to generate a utility management plan to the approval of the Engineer .</p> <p>Any damage or disturbances caused to any service shall be reported immediately to the Engineer and the relevant Authority and shall be made good to their satisfaction at the Contractor's expense.</p> <p><b>Carried to collection</b></p>	



ITEM	DESCRIPTION	AMOUNT
A	<p><b><u>MATERIALS, TOOLS, PLANT AND SCAFFOLDINGS</u></b></p> <p>All materials and workmanship used in the execution of the works shall be of the best quality and description. Any materials for the works condemned by the Engineer shall immediately be removed from the site at the Contractor's expense.</p> <p>The Contractor shall be responsible for the provision of all materials, scaffolding, tools, plant, transport and workmen required for the works except in so far as may be stated otherwise herein and he shall allow for the provision of the foregoing except for such items specifically and only required for the use of Nominated Sub-contractors as described herein.</p> <p>No timber used for scaffolding, formwork or similar purpose shall be used afterwards in the permanent works.</p> <p>All such plant, tools and scaffolding shall comply with all regulations whether general or local in force including Environmental, Social, Health and Safety (ESHS) policies throughout the period of the contract and shall be required as may be necessary to comply with any amendments in or additions to such regulations</p> <p>The Contractor shall keep on the site and maintain in good condition one dumpy or quickset level, metric leveling staff and one 30 metre steel tape for the use of the Architect, Surveyor and Engineer.</p> <p>The contractor may be required to provide an appropriate tower crane as required during the project life. Where a crane is provided, it should meet all regulatory and technical standards, all licences in connection with erection, usage shall be at the Contractors expense.</p> <p>The contractor may be required to provide an appropriate tower crane as required during the project life. Where a crane is provided, it should meet all regulatory and technical standards, all licences in connection with erection, usage shall be at the contractors expense.</p>	
	<p><b>Carried to collection</b></p>	

ITEM	DESCRIPTION	AMOUNT
A	<p><b><u>LOCAL REGULATIONS AND BY-LAWS</u></b></p> <p>The contractor is to comply with all local regulations and by-laws of the Local Authority including serving notices and paying of fees where applicable. These include, but not limited to: National Environmental Management Authority (NEMA), National Construction Authority (NCA), Water Resources Authority (WRA)</p> <p>The Contractor will be held responsible for serving on the Chief Inspector of Factories a written notice not later than seven days after the beginning of the building operations included in this contract stating the particulars required.</p> <p><b><u>TRANSPORT TO AND FROM THE SITE</u></b></p> <p><b>B</b> The Contractor shall include in his prices for the transport of materials, workmen etc to and from the site of the proposed works at such hours and by such routes as are permitted by the Authorities.</p> <p>All unit rates for local or imported goods are to include freight, insurance, handling and delivery costs to the project site together with import duties, sale tax, port charges etc and all other charges of whatever nature.</p>	
	<p><b>Carried to collection</b></p>	

ITEM	DESCRIPTION	AMOUNT
A	<p><b><u>FAIR WAGES</u></b></p> <p>The Contractor shall pay rates of wages and observe hours and conditions of labour not less favourable than the minimum conditions of employment applicable in the area in which the work is carried out. The relevant notice must be posted up and kept posted upon the site where it can be conveniently read by the employees concerned in languages they can understand.</p> <p>The Contractor is to comply with the regulations of Wages and Conditions of Employment Act, Building and Construction Industry Wages Council and is to be responsible for compliance of the sub-contractors employed in the execution of the contract. If required he is to notify the Engineer of the names and addresses of all such Sub-contractors. Any Contractor or Sub-contractors not complying will not be permitted to tender for other work for such a period as the Engineer may determine</p> <p>Should a claim be made to the Engineer alleging the Contractor's default in payment of fair wages to any workman employed on the contract and if proof thereof satisfactory to the Engineer, may failing payment by the Contractor, pay the claim out of any monies due or which may become due to the contractor under this contract.</p> <p>The Contractor is to furnish to the Engineer, if called upon to do so, such particulars of the rates of wages, hours and conditions of labour referred to above as the Engineer may direct</p>	
B	<p><b><u>SECURITY OF WORKS</u></b></p> <p>The Contractor shall be entirely responsible and shall pay security of all works, stores, materials, plant, personnel etc both his own and sub-contractors and shall also provide all necessary watching, lighting, and other precautions as necessary to ensure the security, the safety and protection of the public. He is to ensure that there is no informal business settlement near the establishment.</p> <p><b>Carried to collection</b></p>	

ITEM	DESCRIPTION	AMOUNT
A	<p><b><u>OCCUPATIONAL HEALTH AND SAFETY MEASURES</u></b></p> <p>The Engineer expects the Contractor to adhere to strict safety measures. In this regard the Contractor should ensure that all his workers, the Consultants and his sub-Contractors workmen are wearing Personal Protective Equipment (PPE) before commencement of any work where applicable including overalls with the company name clearly printed on the back each with clearly marked Identification Numbers stitched or imprinted on.</p> <p>The Contractor shall allow for providing all watching, lighting, green netting, barriers, signs, covering open trenches and protection of the works, including Sub-Contract works, as may be necessary for the safety of the works and for the protection of the public and his own and Sub-Contractors' employees.</p> <p>He shall also ensure provision of a certified and qualified safety, health and environmental officer, access to ambulance services at all worksites and arrangement to access a local hospital/dispensary with qualified medical staff.</p> <p>The contractor shall take cognisance and shall fully adhere to the regulations of the <b>Occupational Safety and Health Act of 2007</b> including all the associated revisions</p> <p>The Engineer shall expect full compliance to this regulation and no excuses will be entertained for non-compliance which may lead to suspension of works until the issue is addressed satisfactorily.</p>	
B	<p><b><u>PUBLIC, PRIVATE ROADS AND PAVEMENTS ETC</u></b></p> <p>The contractor will be required to make good at his own expense any damages he may cause to the present approach and surrounding road surfaces during the period of the works</p>	
C	<p><b><u>POLICE REGULATIONS</u></b></p> <p>The contractor is to allow for complying with all Government Acts, orders or regulations in connection with employment of labour and other matters related to the execution of the works.</p> <p>The Contractor must acquit himself duly with current acts and regulations, including police regulations regarding the movement, housing, security and control of labour, labour camps, passes for transport, etc..</p>	
	<p><b>Carried to collection</b></p>	

ITEM	DESCRIPTION	AMOUNT
A	<p><b><u>AREA TO BE OCCUPIED BY CONTRACTOR</u></b></p> <p>The area of the site which may be occupied by the Contractor for use as storage and for the purpose of erecting workshops etc shall be defined on the site by the Engineer</p>	
B	<p><b><u>PROGRESS SCHEDULE</u></b></p> <p>Immediately after signing the contract the Contractor is to prepare a Time Progress Chart showing the time and order in which he proposes to carry out the works within the total construction time stated in the contract. The chart will show in detail the construction time and order in which each section of the work is to be carried out and be sub-divided into trades and tasks. If the contractor proposes sectional completion of the project he must plan this in detail including access roads, and services and this shall be reflected on the chart</p> <p>Upon the letting of the Sub-Contractors work the Contractor is to incorporate times and details of each separate Sub-Contractor work which information is to be agreed by the Sub-Contractor and the chart will be so designed to accommodate this infantine.</p> <p>At the end of each week the Contractor is to mark on the chart in a different colour the actual time taken to complete the respective stages and sections of the work. The contractor shall obtain the Engineer's approval on the chart and then shall supply copies to the Engineer and Quantity Surveyor</p> <p>If at any time it should appear to the Engineer that the actual progress of the works does not conform to the approved programme progress schedule the Contractor shall produce at the request of the Engineer a revised programme showing the modifications and accelerations to the approved programme necessary to ensure completion of the works within the agreed contract period.</p> <p>The submission of and approval by the Engineer of such revisions and accelerations shall not entitle the Contractor to any extra payment or extension of time and shall not relieve the Contractor of any duties or obligations or responsibilities under the contract</p>	
	<p><b>Carried to collection</b></p>	

ITEM	DESCRIPTION	AMOUNT
A	<p><b><u>OVERTIME</u></b></p> <p>The Contractor shall be responsible for any extra costs for overtime working he considers will be necessary in order to complete the works within the contract period or time for completion apart from overtime working which may be authorised by the Engineer</p> <p>If overtime is worked out in accordance with a written instruction issued by the Engineer the contractor will be reimbursed in respect of such overtime to the unproductive time payable over and above the basic hourly rates as laid down by the Regulation of wages and Conditions of employment Act, Building and Construction Industry Wages Council and excluding any bonuses, profits and overheads.</p>	
B	<p><b><u>WATER</u></b></p> <p>The contractor shall provide at his own risk and cost all water for use in connection with the works including the work of sub-contractors make arrangements with the local authority for the installation of a separate meter where applicable and possible for all water used by him throughout the contract and pay all costs and fees in connection therewith. He shall also provide temporary storage tanks and tubing etc as he may consider necessary and clear away at completion.</p> <p>The contractor is to provide clean drinking water at the construction site for his workers at all times.</p> <p>All water shall be fresh, clean and pure, free from earthly vegetable or organic matter, acid or alkaline substance in solution or suspension.</p>	
C	<p><b><u>TELEPHONE</u></b></p> <p>The contractor shall provide in the office, from the commencement to the completion of the works, a wireless or mobile phone and shall pay all charges or airtime necessary for its use</p>	
D	<p><b><u>LIGHTING AND POWER</u></b></p> <p>The contractor shall provide at his own risk and cost all temporary artificial lighting and power for use on the works including all sub-contractors and specialists requirements and including all temporary connections, wiring, fittings etc and clearing away on completion. The Contractor shall pay all fees and obtain all permits in connection therewith.</p>	
	<p><b>Carried to Collection</b></p>	



ITEM	DESCRIPTION	AMOUNT
A	<p><b><u>TEMPORARY STRUCTURES</u></b></p> <p>a) The Contractor shall allow for providing and clearing away on completion of the works such temporary hoarding , rubbish chutes, gates, planked walkways, guard rails etc. as may be necessary for the protection of the workers, the general public, and for the proper execution of the works.</p> <p>b) As such, temporary structures shall be constructed with the approval of the Engineer and to his full satisfaction and in such a manner as to cause minimum intrusiveness and disturbance to occupants of adjacent developments and users of the adjacent roads.</p> <p>c) All such temporary structures shall comply in all aspects with the national laws, rules, and regulations currently in force and applicable to such structures.</p> <p>d) All temporary structures shall be erected in a manner so that the unloading of materials causes minimum obstruction to the use of adjacent roads and other facilities</p> <p>e) All temporary structures shall be kept properly lighted throughout the periods of darkness and any corners or projections shall be painted white.</p> <p>g) Temporary structures shall not be used or permitted to be used for advertisement purposes except with the written consent of the Engineer</p> <p>h) All temporary structures shall be maintained at all times in good order and good condition to the satisfaction of the Engineer.</p> <p>i) All temporary structures shall be removed when so required by the Engineer or at the end of the period for which it is required.</p> <p>j) The Contractor shall indemnify and shall keep the employer idemnified against any expenses, loss, claim or suits arising out of or in connection with the temporary structures.</p>	
	<p><b>Carried to collection</b></p>	



ITEM	DESCRIPTION	AMOUNT
	<p><b><u>SITE OFFICE</u></b></p> <p><b>A</b> The contractor shall supply, maintain, service, clean and light a fully furnished, suitable office having an approximate floor area of not less than 200sqm. The office shall have a sample room suitable dimensions with clean running water and electricity connected to the approval of the Engineer.</p> <p>The Contractor shall provide offices, messrooms and all other buildings required by the Contractor for his own use and the use of by Clerk of Works and Nominated SubContractors as required by the items or attendance</p> <p>The site office shall be equipped with a table and chairs of sufficient size and number for site meetings and plan chests for drawings shall also be provided by the contractor</p> <p>The Contractor shall allow for the cost of providing light refreshment for the consultants at site meetings.</p> <p><b><u>TEMPORARY DISPOSAL OF RAIN WATER</u></b></p> <p><b>B</b> The Contractor shall provide and maintain all necessary temporary gutters, downpipes, chutes, drains etc. for conveying rainwater from the buildings and storage tanks for rainwater harvesting.</p> <p>The Contractor shall allow for temporary drainage plumbing and piping for keeping the premises and site free from accumulation of water. He shall also allow for construction and maintaining any necessary storm water drainage structures as directed.</p> <p><b><u>CLEARING AWAY</u></b></p> <p><b>C</b> The Contractor shall remove all temporary works, rubbish, debris and surplus materials from the site as they accumulate, on intervals as instructed by the Engineer and upon completion of the works, remove and clear away all plant, equipment, rubbish, unused materials and stains and leave in a clean and tidy state to the reasonable satisfaction of the Engineer.</p> <p>The whole of the works shall be delivered up clean, complete and in perfect condition in every respect to the satisfaction of the Engineer.</p>	
	<p><b>Carried to collection</b></p>	

ITEM	DESCRIPTION	AMOUNT
A	<p><b><u>SITE ACCOMODATION &amp; STORAGE</u></b></p> <p>The Contractor shall provide sheds for storage accommodation for all goods and materials liable to suffer damage from exposure to sunlight or inclement weather.</p> <p>The Contractor shall provide offices, mess rooms and all the buildings required by the Contractor for his own use and the use of Nominated Sub-Contractors as required by the items of attendance only.</p> <p>The Contractor shall provide at his own risk and cost where directed on the site weather proof lock-up sheds and make good damaged or disturbed surfaces upon completion to proof lock-up sheds and make good damaged or disturbed surfaces upon completion to the satisfaction of the Engineer</p> <p>Upon completion all temporary buildings are to be removed and cleared away</p>	
B	<p><b><u>SANITATION OF THE WORKS</u></b></p> <p>The sanitation of the works shall be provided, maintained and removed on completion by the Contractor to the satisfaction of the Engineers and local Authorities.</p> <p>The sanitary facilities shall be of generally acceptable standard regardless of the material being used to ensure ease of cleaning and maintain general well being of the users. Their location shall be agreed with the Engineers and the works shall not be commenced before the sanitary accommodation has been approved by the above mentioned authorities.</p> <p>The Contractor will be required to pay all conservancy charges and shall ensure clean daily maintenance and disinfecting of the sanitary facilities, and not less than once per week, the whole area shall be sprayed with disinfectant and insecticides and any temporary drains shall be removed and all works and surfaces disturbed made good and then the whole area disinfected and left clean and free from pollution to the satisfaction of the Engineer and local authorities.</p>	
C	<p><b><u>HOARDINGS</u></b></p> <p>The Contractor shall provide, erect and maintain throughout the course of the Contract and thereafter clear away and make good disturbed areas, temporary hoarding; <b>approximate length of 1000 metres:</b> 2400mm high above ground consisting of: 100mm diameter timber poles at 1200mm centres firmly founded and secured, 75x50mm horizontal timber rails at 900mm centres, painted GCI sheets, proper timber gates with suitable locks to Engineers approval.</p> <p><b>Carried to collection</b></p>	

ITEM	DESCRIPTION	AMOUNT
A	<p><b><u>DEMOLITIONS AND DOWNTAKINGS</u></b></p> <p>The Contractor is to allow for all temporary protection required during the works including ordinary and special dust screens, hoardings, barriers, warning signs etc. as directed by the Engineer and as necessary for the adequate protection of adjacent property and finishes, workmen employed upon the site and the public. Any damage or loss incurred due to the insufficiency of such protection must be made good by the Contractor. All protective devices are to be removed on completion of the work and any necessary making good consequent upon this is to be executed to the satisfaction of the Engineer</p> <p>All materials arising from demolitions and downtakings are deemed to be the property of the employer. No claim will be entertained on account of employer excising this right to retain the materials unless otherwise stated.</p> <p>The Contractor shall allow in his rates the cost of handling and disposal of debris arising out of the demolition works</p> <p>All downtakings shall be carefully removed, taken down, dismantled and stored on site until instructed by the Engineer to remove from the site. Such materials shall only be incorporated in the new works if required by the Engineer in which case appropriate adjustments will be made in the final account for the cost of labour, screws etc for fixing such downtakings in the new works.</p> <p>The Contractor shall be entirely responsible for any breakage or damage which may occur to materials required for re-use, during their removal, unless it is certified by the Engineer that such damage or breakage was inevitable as a result of the condition of the item concerned.</p>	
B	<p><b><u>ACCESS TO SITE AND TEMPORARY ROADS</u></b></p> <p>Means of access to the site shall be agreed with the Engineer prior to commencement of the works and the Contractor must allow for building and maintaining any temporary access roads for the transport of materials, plant and workmen as may be required for the complete execution of the works including the provision of temporary culverts, crossings, bridges or any other means of gaining access.</p> <p>Upon the completion the works the Contractor shall remove such temporary roads, temporary culverts bridges etc and make good and reinstate all works and services disturbed to the satisfaction of the Engineer.</p>	
	<p><b>Carried to collection</b></p>	

ITEM	DESCRIPTION	AMOUNT
A	<p><b><u>SIGN BOARD</u></b></p> <p>The Contractor shall provide and erect where directed and maintain during the whole period of the building operation and remove at completion, one approved sign board of <b>approximately 3000x3000mm and approximately 5800mm overall height</b> to the Architect's later design giving a brief description of the works, a 3D perspective image of the project, and showing the names of the employer and the consultants, with sufficient space to append the names of the sub-contractors and suppliers when known. The lettering concerning the Architect, Quantity Surveyor and Engineer is not to be more than 50mm high.</p>	
B	<p><b><u>PRIME COST SUMS</u></b></p> <p>i) The words "Prime Cost" (or the initials "P.C") appearing in the contract documents shall mean net costs exclusive of any trade, cash or other discount whatsoever but inclusive of the costs of the packing, carriage and delivery. Such costs shall be the same due to the sub-contract or supplier after adjustments where applicable in respect of measurements of rates.</p> <p>ii) Any increase or decrease in the prime costs sums resulting from the adjustments and properly paid by the contractor shall be added or deducted from the contract sum in the final account. In substantiation the contractor will require to produce to the Quantity Surveyor all quotations, invoices and receipted accounts as shall be necessary to show the details of the sums actually paid.</p> <p>iii) Any sum added by the contractor in these Bills of Quantities in respect of profits upon any prime costs will be deducted at the final settlement of accounts and the sum will be added to the amount of which will bear the same proportion to the sum added as the net amount properly expended to the original P.C sum. The profit is a management fee for arranging and taking responsibility of the sub-contract works or arranging for and checking the supply of materials and goods from nominated suppliers.</p> <p><b>Carried to collection</b></p>	

ITEM	DESCRIPTION	AMOUNT
A	<p><u>NOMINATED SUB-CONTRACTORS</u></p> <p>The contractor shall accept responsibility for providing the following services for nominated sub-contractors.</p> <p>i) GENERAL ATTENDANCE:</p> <p>The following services are described as "allow for general attendance" . This shall mean:</p> <p>a) Use for the purpose of the sub-contract works of any scaffolding belonging to or provided by the contractor while it remains so erected upon site, provided that no warranty or other liability on the part of the contractor or of his other sub-contractors shall be created or implied in regard to the fitness, condition or suitability of the said scaffolding</p> <p>b) Provision of water, lighting, watching and attendance for the purpose of the sub-contract works.</p> <p>c) Use of sanitary accommodation, mess rooms and welfare facilities.</p> <p>d) Provision of space for erecting of offices or stores or space for storage of plant and materials.</p> <p>ii) SPECIAL ATTENDANCE:</p> <p>The following services are described as "allow for special attendance" . This shall mean:</p> <p>a) Taking delivery and including the provision of unskilled labour necessary to attend upon the sub-contractors workmen for the purpose of unloading plants/equipment and materials of significant weight and/or size, when received upon the site and placing in position within the sub-contractor's storage space or store.</p> <p>b) Special Scaffolding, scaffolding additional to the Contractors scaffolding or Reassembling of contractor's scaffolding.</p> <p>c) Facilitating special power requirements during the course of the works.</p>	
	<p><b>Carried to collection</b></p>	

ITEM	DESCRIPTION	AMOUNT
	<p><b>CLAIMS</b></p> <p><b>A</b> It shall be a condition of this contract that upon it becoming reasonably apparent to the Contractor that he has incurred losses and / or expenses due to any of the contract conditions, or by any other reason whatsoever, he shall present such a claim or intent to claim notice to the Engineer within the contract period. No claim shall be entertained upon the expiry of the said contract period.</p> <p><b>PAYMENTS</b></p> <p><b>B</b> The tenderer's attention is drawn to the fact that the payments shall be made in accordance with Clause 14 of the Conditions of Contract Agreement. In order to facilitate this, a list of the general component elements for the works is given at the summary page of these specifications and the tenderer is requested to break down his tender sum commensurate to the said elements.</p> <p><b>PREVENTION OF ACCIDENT, DAMAGE OR LOSS</b></p> <p><b>C</b> The Contractor is thus instructed to take reasonable care in the execution of the works as to prevent accidents, damage or loss and disruption of activities being carried out. The Contractor shall allow in his rates any expense he deemed necessary by taking such care within the site.</p>	
	<p><b>Carried to collection</b></p>	

ITEM	DESCRIPTION	AMOUNT
A	<p><b><u>NOMINATED SUPPLIERS</u></b></p> <p>The contractor shall take delivery all materials or goods supplied by the Nominated suppliers and shall sign a receipt as having received them in good order and condition. He shall offload, transport to site, unload, hoist, provide safe storage and thereafter be responsible for any loss or damage or replacement of any such lost or damaged articles at his own expense and shall return case if so required.</p> <p>Provision is made herein following each appropriate P.C sums for the costs of the foregoing services against items reading "take delivery of and fix only"</p> <p><u>Fix Only:-</u></p> <p>"Fix Only" shall mean take delivery on site, unload, store, unpack, assemble as necessary, distribute to position, hoist and fix only.</p>	
B	<p><b><u>DIRECT CONTRACTS</u></b></p> <p>Notwithstanding the foregoing conditions, the Government reserves the right to place a "Direct Contract" for any goods or services required in the works which are covered by a P.C. Sum in the Bills of Quantities and to pay for the same direct. In any such instances, profit relative to the P.C. Sum in the priced Bills of Quantities will be adjusted as described for P.C. Sums is allowed.</p>	
C	<p><b><u>PROTECTION OF THE WORK</u></b></p> <p>The Contractor shall cover up and protect all finished work liable to damage including provision of temporary roof, gutters, drains etc until the completion of the works.</p> <p>In the event of any damages occurring to the works, materials, sewers, drains, gullies, paths or other works on site in temporary possession of the contractor for the purpose of this contract either from weather, want of proper protection, defects, or insufficiency of the works or any other causes or whatsoever during the progress of the works, the contractor shall be responsible and without extra charge, make good all damage and pay all costs which may be levied.</p> <p><b><u>BLASTING OPERATIONS</u></b></p>	
D	<p>Blasting will only be allowed with the express permission of the Engineer in writing. All blasting operations shall be carried out at the Contractor's sole risk and cost in accordance with any Government regulations in force for the time being, and any special regulations laid down by the Engineer governing the use and storage of explosives.</p> <p><b>Carried to collection</b></p>	

ITEM	DESCRIPTION	AMOUNT
	<p><b><u>PREVENTION OF NUISANCE</u></b></p> <p><b>A</b> The works and such sections of the site necessary thereafter shall be under the entire care and control of the contractor during the whole period of the contract and shall take all possible precautions to prevent any nuisance, inconvenience or injury to the holder or occupiers of the existing or surrounding properties and to the public generally, and shall at all times keep all paths and roads affected by the works in a safe and clear state, and shall use proper precautions to ensure the safety of all wheeled traffic and pedestrians.</p> <p>The contractor shall provide appropriate screens to seal off the working area.</p> <p><b><u>REMOVAL OF PLANT AND RUBBISH ETC</u></b></p> <p><b>B</b> The Contractor shall upon completion of the works remove and clear away all temporary buildings, plant, rubbish and unused materials, and shall leave the whole of the site of the works in a clean and tidy state to the satisfaction of the Engineer. He shall also remove all rubbish and dirt from the site at intervals or as directed by the Engineer.</p> <p>Particular care shall be taken in leaving windows, floors and fittings clean and the removal of all paint and cement stains therefrom.</p> <p>The contractor is expected to have established a well planned method of solid disposal of debris/garbage on and off the camp site</p> <p><b><u>CONTRACTOR'S SUPERINTENDENCE/SITE AGENT</u></b></p> <p><b>C</b> The Contractor shall constantly keep on the works a literate English speaking Agent or Representative, competent and experienced in the kind of work involved who shall give his whole experience in the kind of work involved and shall give his whole time to the superintendence of the works.</p> <p>Such Agent or Representative shall receive on behalf of the Contractor all directions and instructions from the Engineer and such directions shall be deemed to have been given to the Contractor in accordance with the Conditions of Contract.</p>	
	<p><b>Carried to collection</b></p>	



ITEM	DESCRIPTION	AMOUNT
	<p><b><u>TRAINING LEVY</u></b></p> <p><b>A</b> The Contractor's attention is drawn to legal notice No. 237 of 2007 which requires payment by the Contractor for a training levy and the contractor shall allow in the preliminaries of this contract (basic rates column) for all costs arising or resulting therefrom.</p> <p>Proof of payment of this Levy should be provided at the request of the Engineer</p> <p><b><u>STANDARDS LEVY</u></b></p> <p><b>B</b> The Contractor is required to make payments to the Kenya Bureau of Standards as Standard Levy inline with the current current and prevailing regulations.</p> <p><b><u>VALUE ADDED TAX (V.A.T.)</u></b></p> <p><b>C</b> The Contractor's attention is drawn to V.A.T PUBLIC NOTICE NO. 6 of 5th August, 1993 regarding the Finance Bill 1993 which expanded the V.A.T base to cover construction services amongst other items. The Contractor's attention is also drawn to all other notices issued by the government in relation to taxation. The Contractor shall familiarise himself with the said notices and allow in all his Bills of Quantities rates (Excluding P.C and Provisional Sums) for the net tax. (i.e less input tax where applicable) as required by law.</p> <p>Please note that allowing a lump sum tax either in preliminaries or in summary page shall not be acceptable.</p> <p>Any additional information and assistance concerning the application of the said notice should be directed to the office of the Commissioner of Value Added Tax</p>	
	<p><b>Carried to collection</b></p>	

ITEM	DESCRIPTION	AMOUNT
	<b><u>BILL NO. 1</u></b>	
	<b><u>GENERAL PRELIMINARIES</u></b>	
	<b><u>COLLECTION</u></b>	
	Carried from page 1/9	
	Carried from page 1/10	
	Carried from page 1/11	
	Carried from page 1/12	
	Carried from page 1/13	
	Carried from page 1/14	
	Carried from page 1/15	
	Carried from page 1/16	
	Carried from page 1/17	
	Carried from page 1/18	
	Carried from page 1/19	
	Carried from page 1/20	
	Carried from page 1/21	
	Carried from page 1/22	
	Carried from page 1/23	
	Carried from page 1/24	
	Carried from page 1/25	
	Carried from page 1/26	
	Carried from page 1/27	
	Carried from page 1/28	
	Carried from page 1/29	
	<b>Total for General Preliminaries Carried to Summary of Bill No. 1</b>	

ITEM	DESCRIPTION	UNIT	AMOUNT
	<p><b><u>BILL NO. 3</u></b></p> <p><b><u>PROJECT EXPENSES</u></b></p> <p><b>Disclaimer: The following items are provisional sums provided by the Engineer. They are to be expended at the written instruction of the Engineer.</b></p> <p><b>Note: Tenderers should not attach, revise or add any conditions or specifications to the project supervisor's expenses</b></p>		
A	Provide and maintain equipment for the Engineer's site office for the duration of the project	Lump Sum	2,500,000.00
B	Provide for supervision as follows: 1 No. Clerks of works, (Building and services) for the duration of project and 1 no. Work Inspectors, and 1 No Surveyor to be engaged on need basis.	Lump Sum	2,700,000.00
C	Allow a provisional sum of Kshs. Eight Million (8,000,000) for Project Management Team and other stakeholders facilitation allowances during project implementation, as and whenever it is necessary.	Lump Sum	8,000,000.00
D	<p>Allow a P.C. Sum of KShs. 8,500,000 for supply of 1 Nr. (one)4WD station wagon SUV zero mileage vehicles of 2500 cc, or approved equivalent, including road licenses, number plates, insurances, etc. The vehicles to revert to Employer after completion of Contract. Minimum specifications include but not limited to the following:</p> <ul style="list-style-type: none"> <li>• Engine - 2.5 litres Turbo Diesel</li> <li>• Rear Differential Gear Lock</li> <li>• Braking System to include ABS (Anti-Lock Brake System)</li> <li>• Power Steering with adjustable Steering Column</li> <li>• Electronic Fuel Injection System.</li> <li>• 5 Speed Semi-Auto Transmission</li> <li>• Power Windows</li> <li>• Immobilizer and Alarm System</li> <li>• Fuel tank capacity between 80 litres and 100 litres</li> </ul>	Item	8,500,000.00
E	Provide for the driver, fuels, maintenance, lubricants and servicing of the vehicle for kilometrage over 1,500 km per vehicle month.	Item	1,440,000.00

ITEM	DESCRIPTION	UNIT	AMOUNT
A	Provide a Prime-cost sum of Kshs five Hundred Thousand, (500,000.00) only for carrying out environmental impact assessment before the commencement of works and and undertaking environmental mitigation measures as the work progresses.	Item	500,000.00
B	Provide a Prime-cost sum of Kshs one million, (1,000,000.00) only for carrying out Geotechnical survey before the commencement of works and preparation of the reports	Item	1,000,000.00
C	Allow a provisional sum of Kshs. Two Hundred and Fifty Thousand (250,000.00) for stationery, documentation, model making, review and preparation of as built drawings Manager.	Item	250,000.00
D	Allow a provisional sum of Kshs. Three Hundred and Fifty Thousand (350,000.00) for provision of Laptop Computer for the Engineer's Team.	Item	350,000.00
<b>Contractor's profits and overheads</b>			
E	Allow for the Contractor's overheads and profits on items above		
<b>Total for Project Expenses Carried to Summary of Bill No. 1</b>			

**BUILDERS WORK**

**BLOCK TYPE A**

Item	Description	Unit	QTY	Rate	Block A G+9 Amount
<b><u>PROPOSED SOCIAL + AFFORDABLE UNITS BLOCK</u></b> <b><u>(TYPE A G+9)</u></b>					
<b>BILL NO.4 -BLOCK A</b>					
<b>ELEMENT NO 1 - SUBSTRUCTURES (ALL PROVISIONAL)</b>					
<u>Site Clearance</u>					
A	Clear site of all grass, hedges, shrubs, bushes grub up roots, load and remove from site and dispose at designated local authority areas.	SM	682		
B	Bulk excavation to reduce levels depth not exceeding 1.5m commencing from existing ground level	CM	1,022		
C	Ditto but exceeding 1.5 metres but not 3 metres deep	CM	682		
D	Extra over all type of excavation for excavating in soft rock	CM	85		
E	Ditto excavation in hard rock class I	CM	85		
<b>Disposal of water</b>					
F	Allow for keeping the whole of the excavation free from all spring and running water by pumping or any other such means as may be necessary	Item			
<b>Planking and strutting</b>					
G	Allow for maintaining and upholding the sides of excavations and keeping excavations clear of all fallen materials, rubbish etc	Item			
<b>Carried to collection</b>					

Item	Description	Unit	QTY	Rate	Block A G+P Amount
	<b><u>Disposal of excavated material</u></b>				
A	Load, wheel and cart away surplus excavated material to a Local Authority designated dumping site or fill soil heaps as away from site instructed by the Project Engineer.	CM	656		
B	Return, fill and ram selected excavated material around sides of foundations.	CM	1049		
	<b>Fillings</b>				
C	Make up levels using approved imported materials: compacted in layers not exceeding 300mm thick with a roller: to the satisfaction of the Structural Engineer.	CM	821		
D	300mm thick hardcore bed: hand packed : compacted in layers not exceeding 150mm thick: to the satisfaction of the Structural Engineer	SM	456		
E	50 mm Stone dust/ Murrum blinding to surfaces of hardcore	SM	456		
	<b>Anti - termite to treatment</b>				
F	Approved anti-termite treatment, with ten-year guarantee, sprayed to surfaces of hardcore strictly in accordance with manufacturer's instructions.	SM	532		
	<b>Damp-proof membrane</b>				
G	1000 gauge polythene or other equal and approved damp-proof membrane, laid over blinded hardcore (measured separately) with 300mm side and end laps (measured nett-allow for laps); 1 No. layer: bedded in and including cement and sand (1:3) mortar	SM	532		
	<b>Concrete Blinding</b>				
	<b>In situ concrete Class 15MPa: vibrated:</b>				
H	50 mm thick blinding under raft	SM	682		
I	50 mm thick blinding under ground beams	SM	76		
	<b>In- situ vibrated reinforced concrete Class 25 MPa: in:</b>				
J	Raft Foundation	CM	511		
K	Ground Beams	CM	15		
L	100mm thick surface bed	SM	532		
M	Steps	CM	1		
	<b>In- situ vibrated reinforced concrete Class 30 MPa: in:</b>				
N	Columns	CM	22		
O	200mm thick Lift pit shaft wall	SM	31		
	<b>Carried to collection</b>				



Item	Description	Unit	QTY	Rate	Block A G+P Amount
	<b>Ribbed reinforcement steel bars to KS 573:2014 : Grade 500 high tensile strength including bends, hooks, tying wire and distance blocks; to S.E's detail ( Provisional)</b>				
A	Assorted reinforcement	KGS	24718		
	<b>Mesh fabric reinforcement to KS/EAS 412;2 (2019) BRC A142;200 x 200mm, weighing 2.22kg/m<sup>2</sup> (measured net - no allowance) for laps; in two layers - top &amp; bottom; including bends. tving wire and spacer blocks)</b>				
B	In ground floor slab <u>Modular steel frame with steel plates covering formwork and/or marine board formwork: to:</u>	SM	532		
C	Sides of raft foundation	SM	106		
D	Sides of ground beams	SM	152		
E	Vertical sides to columns	SM	261		
F	Vertical sides to lift shaft walls	SM	61		
G	Edge of slab not exceeding 150mm girth	LM	142		
H	Edges of risers 75 - 150mm high	LM	12		
	<b>Foundation Walling</b> <b>Natural quarry stone walling with a minimum of 7.0 N/mm<sup>2</sup> bedded and jointed in cement and sand (1:4) mortar, reinforced with and including 25 x 3 mm thick hoop iron strips at every alternate course as described in;</b>				
I	200mm thick walls in foundations	SM	724		
	<b><u>Pavings</u></b>				
J	Supply and lay 600 x 600 x 50mm reinforced concrete precast paving slabs around the building including laying, spreading and compacting 100mm thick approved sand bed blinding, on and including 150mm thick compacted hardcore to Engineer's approval.	SM	85		
	<b><u>Plinth</u></b> <b><u>25mm Thick cement and sand (1:4) rendering on concrete or masonry ; wood float finished; to</u></b>				
K	Plinths externally <b><u>Two coats black bitumastic paint on:</u></b>	SM	64		
L	Rendered surfaces <b><u>Cement/sand (1:3) screed with approved waterproofing admixture, steel trowelled hard and smooth to receive waterproofing (m/s)</u></b>	SM	64		
M	20mm thick water proof cement/sand (1:4) screed to lift pit floor prepared to receive water proofing	SM	7		
N	12mm thick water proof cement/sand (1:4) render to wall prepared to receive water proofing	SM	32		
	<b>Carried to collection</b>				

Item	Description	Unit	QTY	Rate	Block A G+P Amount
	<b><u>Waterproofing</u></b>				
	<b><u>CRYSTALLINE WATERPROOFING</u></b>				
	<u>All areas indicated shall be waterproofed by approved cementitious system , provide 10 year guarantee, all to manufacturer's specifications and instructions as described:</u>				
	<u>Two coat slurry application: waterproofing powder: 1kg per m2 per coat, minimum 2 coats to seal all expansion joints, holes, repaired areas and angle fillet or as per manufacturers instructions</u>				
	<u>Application of render coat: waterproofing powder: 1kg per m2 at 4.5mm thick on slabs. Rate shall allow for hacking and preparing all concrete surfaces or as per manufacturers instructions</u>				
A	Horizontal surfaces of lift base	SM	7		
B	Vertical surfaces of Lift shaft walls	SM	32		
	<b>Carried to collection</b>				
	<b>COLLECTION</b>				
	Total brought forward from page no: 1				
	Total brought forward from page no: 2				
	Total brought forward from page no: 3				
	Total brought forward from above				
	<b><u>ELEMENT NO. 1</u></b>				
	<b><u>SUBSTRUCTURES</u></b>	<b>Carried to</b>	<b>Main summary</b>		

Item	Description	Unit	QTY	Rate	Block A G+9 Amount
<b><u>PROPOSED SOCIAL + AFFORDABLE UNITS BLOCK</u></b> <b><u>(TYPE A G+9)</u></b>					
<b>BILL NO.4 -BLOCK A</b>					
<b>ELEMENT No 2 - R.C FRAME</b>					
<b><u>Insitu concrete class 30MPa: vibrated: reinforced</u></b>					
A	Columns	CM	301		
B	200mm thick Lift shaft wall	SM	417		
<b><u>Insitu concrete class 25MPa: vibrated: reinforced</u></b>					
C	Beams	CM	279		
D	Upper Roof Beams	CM	3		
E	130mm thick suspended slabs	SM	3757		
F	150mm thick suspended slabs	SM	1206		
G	150mm thick Tank Slab over stairwell	SM	82		
H	150 mm thick landing	SM	103		
I	Staircases	CM	40		
J	100 mm thick reinforced concrete benches reinforced with BRC mesh A142 complete with formwork and all necessary plasterworks/screed work	SM	24		
<b>Ribbed reinforcement steel bars to KS 573:2014 : Grade 500 high tensile strength including bends, hooks, tying wire and distance blocks: to S.E's detail ( Provisional)</b>					
K	Assorted reinforcement	Kg	148150		
<b><u>Modular steel frame with steel plates covering formwork and/or marine board formwork: to</u></b>					
L	Sides of columns	SM	3597		
M	Sides and soffites of beams	SM	2695		
N	Soffits of suspended slabs	SM	5044		
O	Edges of slab over 75mm but not exceeding 150mm girth	LM	3138		
P	To sloping soffites of staircases	SM	148		
Q	Soffits of landings	SM	103		
R	Riser of steps over 150 mm but not exceeding 225 mm girth	LM	480		
S	Staircase string 300mm extreme girth and cut to profile of steps	LM	247		
T	Edges of landing over 150 but ot exceeding 225mm high	LM	80		
U	Sides of lift walls	SM	834		
V	Edges of lift shaft openings 150-225mm high	LM	114		
<b><u>ELEMENT NO. 2</u></b>		<b>Carried to</b>			
<b><u>R.C FRAME</u></b>		<b>Main summary</b>			

Item	Description	Unit	QTY	Rate	Block A G+9 Amount
<b>PROPOSED SOCIAL + AFFORDABLE UNITS BLOCK (TYPE A G+9)</b>					
<b>BILL NO.4 -BLOCK A</b>					
<b>ELEMENT No 3-WALLING</b>					
<b>WALLING</b>					
<b>External Walling</b>					
<i>Machine cut quarry stone walling with a minimum of 7.0 N/mm<sup>2</sup> average compressive strength ;bedded and jointed in cement and sand (1:4) mortar, reinforced with and including 25 x 3 mm thick hoop iron strips at every alternate course as described in;</i>					
A	200mm thick walling Externally	SM	2967		
B	200mm thick parapet walling	SM	308		
<b>Internal Walling</b>					
<i>Machine cut quarry stone walling with a minimum of 7.0 N/mm<sup>2</sup> average compressive strength ;bedded and jointed in cement and sand (1:4) mortar, reinforced with and including 25 x 3 mm thick hoop iron strips at every alternate course as described in;</i>					
C	200mm thick walling Internally	SM	2214		
D	150mm thick walling Internally	SM	2781		
E	100mm thick walling Internally	SM	238		
F	Approved hessian based damp proof course to 200mm thick walling in cement/sand mortar	LM	266		
G	Approved hessian based damp proof course to 150mm thick walling in cement/sand mortar	LM	150		
<b>Precast Concrete Breeze Ventilation Blocks</b>					
H	150 x 150mm wide x 50mm thick Pre Cast Concrete flower 3D breeze ventilation blocks bedded and jointed in cement and sand (1:4) mortar	SM	233		
<b>COPING</b>					
I	600 x 350 wide x 100mm thick insitu reinforced concrete class 20Mpa coping, throated and weathered and jointing to columns with cement sand 1:4 mortar	NO	79		
J	Ditto 300 x 100mm insitu concrete coping to walls twice weathered and throated;	LM	257		
<b>Lintols</b>					
K	200mm x 200mm Deep lintols in reinforced concrete class 20MPa with and including 4No T10 and T8 stirups at 200mm centres; complete with formwork	LM	592		
<b>ELEMENT NO. 3</b>		<b>Carried to</b>			
<b>WALLING</b>		<b>Main summary</b>			

Item	Description	Unit	QTY	Rate	Block A G+9 Amount
	<p align="center"><b><u>PROPOSED SOCIAL + AFFORDABLE UNITS BLOCK</u></b> <b><u>(TYPE A G+9)</u></b></p> <p align="center"><b>BILL NO.4 -BLOCK A</b></p> <p><b>ELEMENT NO 4-WINDOWS</b></p> <p><b><u>MILD STEEL WINDOWS</u></b></p> <p>Supply, fabricate and fix the following purpose made small pane mild steel casement windows to be fabricated from approved mild steel sections (atleast 14g 2mm thick ) comprising of frame and casement incorporating permanent hooded high level ventilation panels infilled with mosquito gauze : window supplied complete with and including 12mm solid square burglar proofing bars fixed at 200mm centres both ways and metal fixing lugs including building into wall and making good, and all necessary iron mongery viz hinges, fasteners, and hasp including shop priming window with red oxide primer before delivery to site:-</p> <p><u>A prime cost sum of Kshs 4,500 per Sqm has been allowed for fabrication of the above specified Steel casement Windows by AHP juakali artisans as approved by the Project Manager/ Architect.</u></p> <p><u>The contractor's unit rate shall include the cost of transport, storage, fixing and all associated accesories in addition to the PC Rate</u></p>				
A	Window, overall size 1200 X 1500mm high to Architects Details (Lounge)	NO	111		
B	Ditto Size 1200 x 1500mm high (bedroom)	NO	150		
C	Ditto Size 1200 x 1200mm high (Kitchen)	NO	80		
D	Ditto Size 600 x 900mm high (WC/SH)	NO	171		
	<b><u>Glazing</u></b>				
E	4mm Thick clear sheet glass panes over 0.1 but not exceeding 0.5 square meters; fixing with premium putty	SM	601		
F	Ditto; obscure	SM	97		
	<b><u>Painting and Decorations</u></b>				
	<b><u>On Metal work</u></b>				
	<b><u>Prepare and apply aerosol spray painting in two finishing coats of first grade paint as per the manufacturer's printed instructions to: -</u></b>				
G	General window and grille surfaces; over 300mm girth internal	SM	1397		
	<b>Carried to Collection</b>				



Item	Description	Unit	QTY	Rate	Block A G+9 Amount
<b>PROPOSED SOCIAL + AFFORDABLE UNITS BLOCK (TYPE A G+9) BILL NO.4 -BLOCK A</b>					
<b>ELEMENT NO 5-DOORS</b>					
<b><u>External Doors</u></b>					
<b><u>Hardwood Panelled Doors</u></b>					
<b><u>50mm thick approved hardwood PANEL doors with 12.5mm thick mahogany hardwood lipping to Architect's details, specifications and approval</u></b>					
<b><u>A prime cost sum at the rate indicated below has been allowed for fabrication of the above specified Hardwood panelled door leaves by AHP juakali artisans as approved by the Project Manager/Architect.</u></b>					
<b><u>The contractor's unit rate shall include the cost of transport, storage, fixing and all associated accessories in addition to the PC Rate.</u></b>					
A	Double leaf door size 1500 x 2400mm high ( PC Rate Kshs 41,000)	NO	3		
B	Single leaf Size 900 x 2400mm high (- PC Rate Kshs 25,000)	NO	111		
<i>Frames and frame finishes in mahogany timber:</i>					
C	25 x 25mm quadrant beading (PC Rate Kshs 75)	LM	663		
D	25 x 50mm architrave with two labours, plugged (PC Rate Kshs 150)	LM	663		
E	150mm x 50mm frame with three labours; chamfered edges; plugged (PC Rate Kshs 1400)	LM	663		
<b>Carried to collection</b>					

Item	Description	Unit	QTY	Rate	Block A G+P Amount
	<p><b><u>Internal Doors</u></b></p> <p><b><u>Flush timber doors</u></b></p> <p><b><u>50 mm thick Semi Solid cored flush doors with plywood facing to receive painting (m.s) all to Architects details, specifications and approval</u></b></p> <p><b><u>A prime cost sum at the rate indicated below for fabrication of the above specified Timber Flush door leaves by AHP juakali artisans as approved by the Project Manager/Architect.</u></b></p> <p><b><u>The contractor's unit rate shall include the cost of transport, storage, fixing and all associated accesories in addition to the PC Rate.</u></b></p>				
F	Door size 900mm x 2400mm High comprising of 1 No Opennable leaf size 800 x 2100mm high including fixed fanlight size 900 x 300mm high in 4mm clear glass ( measured separately) (PC Rate Kshs 4,000)	NO	150		
G	Ditto 800 x 2100mm high comprising of 1No. Opennable leaf size 700 x 2100mm high (PC Rate Kshs 3,500)	NO	171		
	<b>4mm Thick clear sheet glass fixing with matching timber glazing beads to timber frames</b>				
H	In panes exceeding 0.1 sqm but not exceeding 0.5 square metres.	SM	41		
	<i><u>Frames and frame finishes in cypress Timber</u></i>				
I	25 x 25mm quadrant (PC Rate Kshs 75)	LM	1710		
J	25 x 50mm architrave with two labours, plugged (PC Rate Kshs 150)	LM	1710		
K	150mm x 50mm transome with three labours; chamfered edges; plugged (PC Rate Kshs 800)	LM	135		
L	150mm x 50mm frame with three labours; chamfered edges; plugged (PC Rate Kshs 800)	LM	1710		
	<b>Carried to collection</b>				



Item	Description	Unit	QTY	Rate	Block A G+P Amount
	<u>Painting and decorating</u>				
	<u>Priming back of frame with an aluminium or equivalent and approved wood primer</u>				
A	Surfaces not exceeding 100mm girth	LM	4745		
B	Surfaces over 100mm but not exceeding 200mm girth	LM	2373		
	<u>Prepare Knot, prime, stop and apply one undercoat and two finishing coats first grade timber quality paint to wood surfaces as per the manufacturer's printed instructions</u>				
C	General timber surfaces	SM	1750		
D	Surfaces over 200mm but not exceeding 300mm girth	LM	2373		
E	Architraves: not exceeding 100 mm girth□	LM	2373		
F	Quadrant beading : not exceeding 100 mm girth	LM	2373		
	<b>Ironmongery</b>				
	<b>Supply and fix the following ironmongery to timber complete with matching screws and keys to the approval of the Architect</b>				
G	100mm pressed steel Butt Hinges	PRS	657		
H	Stainless steel 3 Lever Mortice Door Lock with handle furniture set;( keyhole escutcheons, cylinder and latch )	NO	114		
I	Ditto: but 2 Lever Door Lock with handle	NO	321		
J	Door fixing cramps	NO	435		
K	200 x 75 x 3mm perspex door signage with door numbers as per Architect detail	NO	0		
L	Block sign with block type, name and number lin exterior quality paint as per Architect detail	NO	0		
	<b>Carried to Collection</b>				
	<b>COLLECTION</b>				
	Total brought forward from page no: 10				
	Total brought forward from page no: 11				
	Total brought forward from above				
	<b>ELEMENT NO. 5</b>	<b>Carried to</b>			
	<b>DOORS</b>	<b>Main summary</b>			

Item	Description	Unit	QTY	Rate	Block A G+9 Amount
<b>PROPOSED SOCIAL + AFFORDABLE UNITS BLOCK (TYPE A G+9)</b>					
<b>BILL NO.4 -BLOCK A</b>					
<b>ELEMENT NO 6 - EXTERNAL FINISHES</b>					
<b>EXTERNAL WALL FINISHES</b>					
<b>External Render</b>					
<i>Cement and sand (1:3) render:wood floated: on concrete or blockwork: to</i>					
A	15mm thick to beams, Columns, Slab Moulds and walling externally	SM	5555		
B	Extra over horizontal and vertical pointing in 10mm thick rod in cement and sand mix (1:3) mortar including one coat Bituminous paint	SM	0		
<b>External Painting</b>					
<i>Prepare and apply one coat Alkali Resistant primer followed by two coats of silicon exterior Emulsion paint in accordance with the manufacturers written instructions and to the satisfaction of the architect to</i>					
C	Concrete/masonry surfaces externally-Beam, Column and Slab Moulds	SM	5555		
<b>ROOF FINISHES</b>					
<b>Cement and sand (1:3) screeded beds: on concrete: complete with coloured pigmentation additives and hardener to:</b>					
D	50mm average waterproofed lightweight screed laid to falls and crossfalls to roof slabs -upper roof including gutter bases	SM	617		
<i>Prepare and apply to vertical/horizontal surfaces 4mm thick APP/EPDM water proofing or other equal and approved membrane with surface finish weighing 4kg/sm; laid on primer with torch-on process ;by an approved specialist all in accordance with the manufacturers instructions including provision of a written ten (10) year anti leak guarantee.</i>					
E	4mm thick APP membrane applied to roof slabs	SM	617		
F	Ditto to skirting 200mm high	LM	358		
G	Dress membrane around 100mm rainwater outlet	No.	12		
<i>The Following Flat roof concrete tiles fixed with approved adhesive, laid and jointed with waterproofing bituminous compound</i>					
H	20mm thick interlocking Concrete tiles of size 225 x 225mm with and including cement sand (1:4) backing to falls	SM	582		
<b>ELEMENT NO. 6</b>		<b>Carried to</b>			
<b>EXTERNAL FINISHES</b>		<b>Main summary</b>			

Item	Description	Unit	QTY	Rate	Block A G+9 Amount
<b>PROPOSED SOCIAL + AFFORDABLE UNITS BLOCK (TYPE A G+9)</b>					
<b>BILL NO.4 -BLOCK A</b>					
<b>ELEMENT NO 7 - INTERNAL FINISHES</b>					
<b><u>Internal Wall Finishes</u></b>					
<u>Cement and sand (1:3) backings</u>					
A	15mm thick to receive Ceramic Wall tiles	SM	2757		
B	To receive porcelain wall tiles (m.s.) (Lift Lobby)	SM	172		
<u>Ceramic wall tiles</u>					
<u>Allow a Prime Cost supply rate of Ksh. 1000 per SM (Rate to include cost of purchase, transport, offload, storage, fixing including all necessary adhesives and accessories</u>					
C	Supply and Fix ceramic wall tiles on prepared backings(m.s) with proprietary adhesive; jointed and pointed in matching coloured proprietary grouting; including pvc spacers and expansion joint as necessary: all to Architect's approval. - Wall Surfaces	SM	2757		
<u>Porcelain wall tiles</u>					
<u>Allow a Prime Cost supply rate of Ksh. 1500 per SM (Rate to include cost of purchase, transport, offload, storage, fixing including all necessary adhesives and accessories</u>					
D	Supply and Fix porcelain wall tiles on prepared backings(m.s) with proprietary adhesive; jointed and pointed in matching coloured proprietary grouting; including pvc spacers and expansion joint as necessary: all to Architect's approval. - Wall Surfaces	SM	172		
<u>15mm (minimum) two coat cement, sand (1:3) plaster complete with wire gauze anti-crack mechanism at the intersection of masonry walling and concrete beams as described to:-</u>					
E	Concrete/masonry surfaces	SM	12110		
<b><u>Painting and Decoration</u></b>					
<u>Prepare, Skim and apply Emulsion or universal undercoat followed by 2 finishing coats of soft satin Emulsion paint in accordance with the manufacturers written instructions and to the satisfaction of the architect to</u>					
F	Plastered concrete/masonry surfaces internally	SM	12110		
<b>Carried to Collection</b>					

Item	Description	Unit	QTY	Rate	Block A G+9 Amount
	<b><u>Floor Finishes</u></b>				
	<u>Cement and sand (1:3) screeds, backings, beds etc</u>				
A	32mm bed finished to receive floor Tiles (m.s)	SM	3487		
B	32mm Thick coloured cement sand screed mix 1:3 finished with red oxide to approval	SM	1036		
	<u>Cement and sand (1:3) backings etc</u>				
C	32mm bed finished to receive ceramic tiles to surfaces of Landings (m.s)	SM	103		
D	25 x 300 mm wide treads to receive ceramic tiles (m.s)	LM	432		
E	20 x 150mm risers to receive ceramic tiles (m.s)	LM	480		
	<u>Ceramic Floor tiles</u>				
	<u>Allow a Prime Cost supply rate of Ksh. 1000 per SM (Rate to include cost of purchase, transport, offload, storage, fixing including all necessary adhesives and accessories</u>				
F	Supply and Fix Ceramic tiles; on prepared bed(m.s) with proprietary adhesive; jointed and pointed in matching coloured proprietary grouting: including pvc spacers and expansion joint as necessary: all to Architect's approval.	SM	2365		
G	Ditto Non Slip Ceramic Tiles	SM	1122		
H	Ditto 100mm wide Wall Skirtings	LM	3996		
I	Non Slip Ceramic Tiles to surfaces of Landings	SM	103		
J	Non Slip Ceramic Tiles to 300 mm wide treads	LM	432		
K	Non Slip Ceramic Tiles to 150mm risers	LM	480		
	<u>Wet areas waterproofing - Kitchens, Toilets etc.</u>				
L	Liquid membrane - High build bitumen/ rubber latex emulsion with excellent adhesion, liquid applied to form a seamless flexible water proof/ vapour proof membrane as <b>as per the manufacturer's printed instructions to:</b> solid content =65%, Rubber Content=10% in dried film)				
M	To floors and walls	m <sup>2</sup>	1567		
	<b>Staircase soffit finishes</b>				
	<u>15mm (minimum) two coat cement, sand (1:3) plaster complete with wire gauze anti-crack mechanism at the intersection of masonry walling and concrete beams as described to:-</u>				
N	Soffits of staircase landing	SM	103		
O	Ditto to sloping soffites exceeding 15° from horizontal	SM	148		
P	Staircase string 300mm extreme girth and cut to profile of steps	LM	247		
	<b>Carried to Collection</b>				

Item	Description	Unit	QTY	Rate	Block A G+P Amount
	<b><u>Paint works</u></b>				
	<u>Prepare, skim and apply Emulsion or universal undercoat followed by 3 coats of soft satin Emulsion paint in accordance with the manufacturers written instructions and to the satisfaction of the architect to</u>				
A	Soffits of staircase landing	SM	103		
B	Ditto to sloping soffites exceeding 15° from horizontal	SM	148		
C	Staircase string 300mm extreme girth and cut to profile of steps	LM	247		
	<b><u>Ceiling finishes</u></b>				
	<u>15mm (minimum) two coat cement, sand (1:3) plaster complete with wire gauze anti-crack mechanism at the intersection of masonry walling and concrete beams as described to:-</u>				
D	Soffits of Concrete surfaces	SM	5044		
	<b><u>Painting and Decoration</u></b>				
	<u>Prepare, skim and apply Emulsion or universal undercoat followed by 3 coats of soft satin Emulsion paint in accordance with the manufacturers written instructions and to the satisfaction of the architect to</u>				
E	Plastered ceilings	SM	5044		
	<b>Carried to Collection</b>				

Item	Description	Unit	QTY	Rate	Block A G+P Amount
	<b>COLLECTION</b>				
	Total brought forward from page no: 12				
	Total brought forward from page no: 13				
	Total brought forward from page no: 14				
	<b>ELEMENT NO. 7</b> Carried to				
	<b>INTERNAL FINISHES Main summary</b>				

Item	Description	Unit	QTY	Rate	Block A G+9 Amount
<b>PROPOSED SOCIAL + AFFORDABLE UNITS BLOCK (TYPE A G+9)</b>  <b>BILL NO.4 -BLOCK A</b>  <b>ELEMENT NO 8- BALUSTRADING AND RAILING</b>					
<i>Balustrades and staircase railings</i>					
A	900mm high mild Steel balustrade; comprising 60 x 10mm mild Steel balusters at 900mm centres; bolted to base plate and tread (m.s), with 7No. 25mm diameter horizontal bars, and 75x4mm diameter CHS mild Steel handrail part welded into 60x10mm balustrades; to Architects drawings	LM	159		
B	50mm diameter x 3mm CHS handrail supported by 50 x 50 x 3mm thick SHS balusters anchored to slab with and including w/steel bolts and plates at 1800mm centres smooth welded 100mm high (Staircase)	LM	90		
<i>Prepare, prime and apply one undercoat and two finishing coats first quality gloss oil paint on</i>					
C	General metal surfaces of balustrading (both sides measured overall)	SM	400		
<b>ELEMENT NO. 8</b> <b>BALUSTRADING AND RAILING</b>		<b>Carried to the</b> <b>Main summary</b>			

Item	Description	Unit	QTY	Rate	Block A G+9 Amount
<b>PROPOSED SOCIAL + AFFORDABLE UNITS BLOCK (TYPE A G+9)</b>					
<b>BILL NO.4 -BLOCK A</b>					
<b>ELEMENT NO 9 - JOINERY FITTINGS</b>					
<u>Allow for providing materials, labour and construct fixtures and fittings as per Architects drawings of the following JOINERY FITTINGS AND FIXTURES complete with associated iron mongery;</u>					
<u>NOTE: All blockboard, MDF boards,etc in joinery works shall be lipped with hardwood lipping all round before fixing.</u>					
<u>High level cupboards</u>					
<u>400mm Wide high level kitchen cupboards in 18mm laminated mdf sides &amp; shelves complete with doors, top, bottom &amp; divisions with and including all necessary ironmongery; to Architect's details</u>					
A	High level storage cupboard units 600mm high x 400mm deep	LM	230.00		
<u>Low level kitchen cupboards</u>					
<u>Low level kitchen worktops with 600x600x10mm porcelain tiles top on 100mm thick reinforced concrete slab with A142 BRC mesh, formwork to soffits and slab edges, plater to soffits of slab, screed to top slab, 100mm thick plastered steeper walls, including 300x300x6mm thick ceramic wall tiles on both sides of the wall: 100mm plastered mass concrete plinths in concrete class 15MPa: 18mm laminated mdf sides &amp; shelves complete with doors, shelves, drawers, cutting tiles for kitchen sink (m.s) &amp; all necessary ironmongery; to Architect's details and approval</u>					
B	Low level kitchen cupboards 850mm high x 600mm deep	LM	230		
<u>Bedroom Wardrobes</u>					
<u>600mm Wide x 2200mm high wardrobes in 18mm laminated mdf sides, divisions, drawers, shelves ; ; complete with sliding/ side hung doors, shelves, divisions, shoe racks, hanging rails, drawers, &amp; all necessary ironmongery; 100mm plastered mass concrete plinths in concrete class 15MPa ; to Architect's details</u>					
C	Bedroom wardrobes size 2200mm high x 600mm deep in bedrooms	LM	217		
<b><u>Duct doors</u></b>					
<u>50mm thick laminated MDF duct doors; complete with frames, ironmongery and all necessary paintwork</u>					
D	Duct doors size 300mm wide x 2100mm high	NO.	10		
E	Duct doors size 350mm wide x 2100mm high	NO.	10		
F	Duct doors size 600mm wide x 2100mm high	NO.	50		
G	Duct doors size 500mm wide x 2100mm high	NO.	20		
H	Duct doors size 700mm wide x 2100mm high	NO.	20		
I	Duct doors size 800mm wide x 2100mm high	NO.	20		
<b><u>ELEMENT NO. 9</u></b>		<b>Carried to the</b>			
<b>JOINERY &amp; FITTINGS</b>		<b>Main summary</b>			



Item	Description	Unit	QTY	Rate	Block A G+9 Amount
A	<p><b>PROPOSED SOCIAL + AFFORDABLE UNITS BLOCK (TYPE A G+9)</b></p> <p><b>ELEMENT NO 10 - BUILDERS WORKS IN CONNECTION WITH SERVICES (BWICWS)</b></p> <p><b><u>Plumbing, Drainage and Mechanical Installations</u></b></p> <p>Inspect all drawings and Bills of Quantities for Plumbing, Drainage and Mechanical Installations and allow for all Builder's work associated with the installations; including cutting away and making good after installing a concealed drainage system; including cutting or leaving all holes notches, mortices, sinkings and chases in both the structure and its coverings; including but not limited to forming recess in masonry</p>	Item			
B	<p><b><u>Electrical Services Installations</u></b></p> <p>Inspect all drawings and Bills of Quantities for Electrical Installations and allow for all Builder's work associated with the Electrical installations, including cutting away for and making good after Electrician installing a concealed conduit system including cutting or leaving all holes notches, mortices, sinkings and chases in both the structure and its coverings; including but not limited to forming recess in masonry</p>	Item			
	<p><b><u>ELEMENT NO. 10</u></b> <b>Carried to the</b>  <b>BUILDERS WORKS IN CONNECTION WITH SERVICES (BWICWS)</b>  <b>Main summary</b></p>				

Item	Description	Unit	QTY	Rate	Block A G+9 Amount
<b><u>PROPOSED SOCIAL + AFFORDABLE UNITS BLOCK</u></b> <b><u>(TYPE A G+9)</u></b>					
<b>BILL NO.4 -BLOCK A</b>					
<b>MAIN SUMMARY</b>					
1	<b>Substructures</b>		<b>Page No.</b> <b>A/4</b>		
2	<b>Reinforced Concrete Frame</b>		<b>A/5</b>		
3	<b>Walling</b>		<b>A/6</b>		
4	<b>Windows</b>		<b>A/8</b>		
5	<b>Doors</b>		<b>A/10</b>		
6	<b>External Finishes</b>		<b>A/11</b>		
7	<b>Internal Finishes</b>		<b>A/15</b>		
8	<b>Balustrade and Railing</b>		<b>A/16</b>		
9	<b>Joinery and Fittings</b>		<b>A/17</b>		
10	<b>Builders works in connection with services</b>		<b>A/18</b>		
<b><u>TOTAL FOR 1NO. TYPE A (G+9) BLOCK</u></b>					
<b>NO. OF BLOCKS</b>					
<b>MULTIPLY BY 9.NO OF BLOCKS</b>					
		<b>X 9</b>			<b>9</b>
<b><u>TOTAL FOR TYPE A (G+9) BLOCK(S) CARRIED TO GRAND SUMMARY</u></b>					

**BLOCK TYPE B**

Item	Description	Unit	QTY	Rate	Amount
<b>PROPOSED APARTMENTS FOR AFFORDABLE HOUSING PROGRAM (TYPE B G+9)</b>					
<b>BILL NO.1-BUILDERS WORKS</b>					
<b>ELEMENT NO 1 - SUBSTRUCTURES (ALL PROVISIONAL)</b>					
<i>Site Clearance</i>					
A	Clear site of all grass, hedges, shrubs, bushes grub up roots, load and remove from site and dispose at designated local authority areas.	SM	938		
B	Bulk excavation to reduce levels depth not exceeding 1.5m commencing from existing ground level	Cm	1,407		
C	Ditto but exceeding 1.5 metres but not 3 metres deep	Cm	938		
D	Extra over all type of excavation for excavating in soft rock	Cm	117		
E	Ditto excavation in hard rock class I	Cm	117		
<b>Disposal of water</b>					
F	Allow for keeping the whole of the excavation free from all spring and running water by pumping or any other such means as may be necessary	Item	1		
<b>Planking and strutting</b>					
G	Allow for maintaining and upholding the sides of excavations and keeping excavations clear of all fallen materials, rubbish etc	Item	1		
<b>Carried to collection</b>					

Item	Description	Unit	QTY	Rate	Amount
	<b><u>Disposal of excavated material</u></b>				
A	Load, wheel and cart away surplus excavated material to a Local Authority designated dumping site or fill soil heaps as away from site instructed by the Project Engineer.	CM	1,484		
B	Return, fill and ram selected excavated material around sides of foundations.	CM	862		
	<b>Fillings</b>				
C	Make up levels using approved imported materials: compacted in layers not exceeding 300mm thick with a 10 tonne roller: to the satisfaction of the Structural Engineer.	CM	1,407		
D	300mm thick hardcore bed: hand packed : compacted in layers not exceeding 150mm thick: to the satisfaction of the Structural Engineer	SM	938		
E	50 mm Stone dust/ Murrum blinding to surfaces of hardcore	SM	938		
	<b>Anti - termite to treatment</b>				
F	Approved anti-termite treatment, with ten-year guarantee, sprayed to surfaces of hardcore strictly in accordance with manufacturer's instructions.	SM	938		
	<b>Damp-proof membrane</b>				
G	1000 gauge polythene or other equal and approved damp-proof membrane, laid over blinded hardcore (measured separately) with 300mm side and end laps (measured nett-allow for laps); 1 No. layer: bedded in and including cement and sand (1:3) mortar	SM	938		
	<b>Concrete Blinding</b>				
	<b>In situ concrete Class 15MPa: vibrated:</b>				
H	50 mm thick blinding under raft	SM	938		
H	50 mm thick blinding under column bases	SM	-		
I	Ditto; under ground beams	SM	94		
	<b>In- situ vibrated reinforced concrete Class 25MPa: in:</b>				
I	Column bases	CM	-		
J	Ground Beams	CM	19		
N	100mm thick surface bed	SM	672		
	<b>In- situ vibrated reinforced concrete Class 30MPa: in:</b>				
J	Raft	CM	704		
K	Columns	CM	18		
L	200mm thick Lift pit shaft wall	SM	24		
	<b>Carried to collection</b>				

Item	Description	Unit	QTY	Rate	Amount
	<b>Ribbed reinforcement steel bars to KS 573:2014 : Grade 500 high tensile strength including bends, hooks, tying wire and distance blocks; to S.E's detail ( Provisional)</b>				
A	Assorted reinforcement	KGS	31,160		
	<b>Mesh fabric reinforcement to KS/EAS 412;2 (2019) BRC A142;200 x 200mm, weighing 2.22kg/m<sup>2</sup> (measured net - no allowance) for laps; in two layers - top &amp; bottom; including bends, tying wire and spacer blocks)</b>				
B	In ground floor slab	SM	672		
	<u>Modular steel frame with steel plates covering formwork and/or marine board formwork: to:</u>				
C	Sides of the raft	SM	103		
D	Sides of ground beam	SM	188		
E	Vertical sides to columns	SM	219		
F	Vertical sides to lift shaft walls	SM	48		
G	Edge of slab not exceeding 150mm girth	LM	162		
	<b>Foundation Walling</b>				
	<b>Natural quarry stone walling with a minimum of 7.0 N/mm<sup>2</sup> bedded and jointed in cement and sand (1:4) mortar, reinforced with and including 25 x 3 mm thick hoop iron strips at every alternate course as described in;</b>				
H	200mm thick walls in foundations	SM	266		
	<b><u>Pavings</u></b>				
	Supply and lay 600 x 600 x 50mm reinforced concrete precast paving slabs around the building including laying, spreading and compacting 100mm thick approved sand bed blinding, on and including 150mm thick compacted hardcore to Engineer's approval.				
I		SM	97		
	<b><u>Plinth</u></b>				
	<b><u>25mm Thick cement and sand (1:3) rendering on concrete or masonry ; wood float finished; to</u></b>				
J	Plinths externally	SM	49		
	<b>Two coats black bitumastic paint on:</b>				
K	Rendered surfaces	SM	49		
	<b>Carried to collection</b>				

Item	Description	Unit	QTY	Rate	Amount
	<b><u>Cement/sand (1:3) screed with approved waterproofing admixture, steel trowelled hard and smooth to receive waterproofing (m/s)</u></b>				
A	20mm thick water proof cement/sand (1:3) screed to lift pit floor prepared to receive masterseal water proofing	m <sup>2</sup>	9		
B	12mm thick water proof cement/sand (1:3) render to wall prepared to receive water proofing	m <sup>2</sup>	26		
	<b><u>Waterproofing</u></b>				
	<b><u>CRYSTALLINE WATERPROOFING</u></b>				
	<u>All areas indicated shall be waterproofed by approved cementious system . provide 10 year guarantee, all to manufacturer's specifications and instructions as described:</u>				
	<u>Two coat slurry application: waterproofing powder: 1kg per m2 per coat, minimum 2 coats to seal all expansion joints, holes, repaired areas and angle fillet or as per manufacturers instructions</u>				
	<u>Application of render coat: waterproofing powder: 1kg per m2 at 4.5mm thick on slabs. Rate shall allow for hacking and preparing all concrete surfaces or as per manufacturers instructions</u>				
C	Horizontal surfaces of lift base	m <sup>2</sup>	9		
D	Vertical surfaces of Lift shaft walls	m <sup>2</sup>	26		
	<b>Carried to collection</b>				
	<b>COLLECTION</b>				
	Total brought forward from page no:				
	Total brought forward from page no:				
	Total brought forward from page no:				
	Total brought forward from above				
	<b><u>ELEMENT NO. 1</u></b>	<b>Carried to</b>			
	<b><u>SUBSTRUCTURES</u></b>	<b>Main summary</b>			

Item	Description	Unit	QTY	Rate	Amount
<b>PROPOSED APARTMENTS FOR AFFORDABLE HOUSING PROGRAM (TYPE B G+9)</b>					
<b>BILL NO.1-BUILDERS WORKS</b>					
<b>ELEMENT No 2 - R.C FRAME</b>					
<b><u>In situ concrete class 30MPa: vibrated: reinforced</u></b>					
A	Columns	CM	273		
B	Lift shaft wall	SM	415		
<b><u>In situ concrete class 25MPa: vibrated: reinforced</u></b>					
C	Beams	CM	312		
D	Upper Roof Beams	CM	14		
E	130mm thick suspended slabs	SM	4,641		
F	Ditto but 150mm thick	SM	2,094		
G	150mm thick Tank Slab over stairwell	SM	48		
H	150 mm thick landing	SM	101		
I	Staircases	CM	40		
<b>Ribbed reinforcement steel bars to KS 573:2014 : Grade 500 high tensile strength including bends, hooks, tying wire and distance blocks; to S.E's detail ( Provisional)</b>					
J	Assorted reinforcement	Kg	165,793		
<b><u>Modular steel frame with steel plates covering formwork and/or marine board formwork: to</u></b>					
K	Sides of columns	Sm	3,240		
L	Sides and soffites of beams	Sm	3,086		
M	Soffits of suspended slabs	Sm	6,782		
N	Edges of slab over 150mm but not exceeding 225mm girth	Lm	2,236		
O	To sloping soffites of staircases	SM	154		
P	Soffits of landings	SM	101		
Q	Riser of steps over 150 mm but not exceeding 225 mm girth	LM	480		
R	Staircase string 300mm extreme girth and cut to profile of steps	LM	268		
S	Edges of landing over 150 but ot exceeding 225mm high	Lm	96		
T	Edges of lift shaft openings 150-225mm high	LM	114		
U	Sides of lift walls	SM	829		
<b><u>ELEMENT NO. 2</u></b>		<b>Carried to</b>			
<b><u>R.C FRAME</u></b>		<b>Main summary</b>			



Item	Description	Unit	QTY	Rate	Amount
<b>PROPOSED APARTMENTS FOR AFFORDABLE HOUSING PROGRAM (TYPE B G+9)</b>					
<b>BILL NO.1-BUILDERS WORKS</b>					
<b>ELEMENT No 3-WALLING</b>					
<b>WALLING</b>					
<b>External Walling</b>					
<i>Machine cut quarry stone walling with a minimum of 7.0 N/mm<sup>2</sup> average compressive strength ;bedded and jointed in cement and sand (1:4) mortar, reinforced with and including 25 x 3 mm thick hoop iron strips at every alternate course as described in;</i>					
A	200mm thick walling Externally	Sm	3,440		
B	200mm thick parapet walling	Sm	193		
<b>Internal Walling</b>					
<i>Machine cut quarry stone walling with a minimum of 7.0 N/mm<sup>2</sup> average compressive strength ;bedded and jointed in cement and sand (1:4) mortar, reinforced with and including 25 x 3 mm thick hoop iron strips at every alternate course as described in;</i>					
C	200mm thick walling Internally	Sm	2,377		
D	150mm thick walling Internally	Sm	2,973		
E	Approved hessian based damp proof course to 200mm thick walling in cement/sand mortar	Lm	282		
F	Approved hessian based damp proof course to 150mm thick walling in cement/sand mortar	Lm	179		
<b>Precast Concrete Breeze Ventilation Blocks</b>					
G	150 x 150mm wide x 50mm thick Pre Cast Concrete flower 3D breeze ventilation blocks bedded and jointed in cement and sand (1:4) mortar	Sm	405		
<b>COPING</b>					
	600 x 350 wide x 100mm thick insitu reinforced concrete class 20Mpa coping, throated and weathered and jointing to columns with cement sand 1:4 mortar	No	84		
H	Ditto 300 x 100mm concrete coping to walls twice weathered and throated;	LM	209		
<b>Lintols</b>					
I	200mm x 200mm Deep lintols in reinforced concrete class 20MPa with and including 4No T10 and T8 stirups at 200mm centres; complete with formwork	LM	798		
<b>ELEMENT NO. 3</b>		<b>Carried to</b>			
<b>WALLING</b>		<b>Main summary</b>			

Item	Description	Unit	QTY	Rate	Amount
	<p><b><u>PROPOSED APARTMENTS FOR AFFORDABLE HOUSING PROGRAM (TYPE B G+9)</u></b></p> <p><b>BILL NO.1-BUILDERS WORKS</b></p> <p><b>ELEMENT NO 4-WINDOWS</b></p> <p><b><u>MILD STEEL WINDOWS</u></b></p> <p>Supply, fabricate and fix the following purpose made small pane mild steel casement windows to be fabricated from approved mild steel sections (atleast 14g 2mm thick ) comprising of frame and casement incorporating permanent hooded high level ventilation panels infilled with mosquito gauze : window supplied complete with and including 12mm solid square burglar proofing bars fixed at 200mm centres both ways and metal fixing lugs including building into wall and making good, and all necessary iron mongery viz hinges, fasteners, and hasp including shop priming window with red oxide primer before delivery to site:-</p> <p>A prime cost sum of Kshs 4,500 per Sqm has been allowed for fabrication of the above specified Steel casement Windows by AHP juakali artisans as approved by the Project Manager/Architect.</p> <p>The contractor's unit rate shall include the cost of transport, storage, fixing and all associated accesories in addition to the PC Rate.</p>				
A	Window, overall size 1500 X 1200mm high to Architects Details (Lounge)	NO	80		
B	Ditto Size 1500 x 1200mm high (bedroom)	NO	200		
C	Ditto Size 1200 x 1200mm high (Kitchen)	NO	80		
D	Ditto Size 900 x 600mm high (WC/SH)	NO	200		
	<b><u>Glazing</u></b>				
E	4mm Thick clear sheet glass panes over 0.1 but not exceeding 0.5 square meters; fixing with premium putty	SM	619		
	Ditto; obscure	SM	108		
	<b><u>Painting and Decorations</u></b>				
	<b><u>On Metal work</u></b>				
	<b><u>Prepare and apply aerosol spray painting in two finishing coats of first grade paint as per the manufacturer's printed instructions to: -</u></b>				
F	General window and grille surfaces; over 300mm girth internal	SM	1,454		
	<b>Carried to Collection</b>				

Item	Description	Unit	QTY	Rate	Amount
	<p><b><u>Precast concrete window cill finishing fair on all exposed surfaces and hoisting and placing in position, bedding, jointing and pointing in pigmented cement and sand (1:3) mortar</u></b></p>				
A	150 x 25mm thick Precast concrete window sill	LM	808		
	<p><b><u>Curtain rods;</u></b></p>				
B	1.5mm thick, 20mm thick diameter twin powdercoated mild steel rod complete accessories to approval	LM	624		
	<b>Carried to collection</b>				
	<b>COLLECTION</b>				
	Total brought forward from page no:				
	Total brought forward from page no:				
<p><b><u>ELEMENT NO. 4</u></b> <b><u>WINDOWS</u></b></p>	<p><b>Carried to the</b> <b>Main summary</b></p>				

Item	Description	Unit	QTY	Rate	Amount
	<b>PROPOSED APARTMENTS FOR AFFORDABLE HOUSING PROGRAM (TYPE B G+9)</b>				
	<b>BILL NO.1-BUILDERS WORKS</b>				
	<b>ELEMENT NO 5-DOORS</b>				
	<b>External Doors</b>				
	<b>Hardwood Panelled Doors</b>				
	<b>50mm thick approved hardwood PANEL doors with 12.5mm thick Meru oak hardwood lipping to Architect's details, specifications and approval</b>				
	<b>A prime cost sum at the rate indicated below has been allowed for fabrication of the above specified Hardwood panelled door leaves by AHP juakali artisans as approved by the Project Manager/Architect.</b>				
	<b>The contractor's unit rate shall include the cost of transport, storage, fixing and all associated accessories in addition to the PC Rate.</b>				
A	Double leaf door size 1500 x 2400mm high ( PC Rate Kshs 41,000)	NO	3		
B	Single leaf Size 900 x 2400mm high (- PC Rate Kshs 25,000)	NO	80		
	<i>Frames and frame finishes in mahogany timber:</i>				
C	25 x 25mm quadrant beading (PC Rate Kshs 75)	LM	483		
D	25 x 50mm architrave with two labours, plugged (PC Rate Kshs 150)	LM	483		
E	150mm x 50mm frame with three labours; chamfered edges; plugged (PC Rate Kshs 1400)	LM	483		
	<b>Internal Doors</b>				
	<b>Flush timber doors</b>				
	<b>50 mm thick Semi Solid cored flush doors with plywood facing to receive painting (m.s) all to Architects details, specifications and approval</b>				
	<b>A prime cost sum at the rate indicated below for fabrication of the above specified Timber Flush door leaves by AHP juakali artisans as approved by the Project Manager/Architect.</b>				
	<b>The contractor's unit rate shall include the cost of transport, storage, fixing and all associated accessories in addition to the PC Rate.</b>				
F	Door size 900mm x 2400mm High comprising of 1 No Opennable leaf size 800 x 2100mm high including fixed fanlight size 900 x 300mm high in 4mm clear glass ( measured separately) (PC Rate Kshs 4,000)	NO	260		
G	Ditto 800 x 2100mm high comprising of 1No. Opennable leaf size 700 x 2100mm high (PC Rate Kshs 3,500)	NO	200		
	<b>4mm Thick clear sheet glass fixing with matching timber glazing beads to timber frames</b>				
H	In panes exceeding 0.1 sqm but not exceeding 0.5 square metres.	SM	70		
	<i>Frames and frame finishes in cypress Timber</i>				
I	25 x 25mm quadrant (PC Rate Kshs 75)	LM	2,482		
J	25 x 50mm architrave with two labours, plugged (PC Rate Kshs 150)	LM	2,482		
K	150mm x 50mm transome with three labours; chamfered edges; plugged (PC Rate Kshs 800)	LM	234		
L	150mm x 50mm frame with three labours; chamfered edges; plugged (PC Rate Kshs 800)	LM	2,482		
	<b>Carried to collection</b>				

Item	Description	Unit	QTY	Rate	Amount
	<u>Painting and decorating</u>				
	<u>Priming back of frame with an aluminium or equivalent and approved wood primer</u>				
A	Surfaces not exceeding 100mm girth	LM	5,930		
B	Surfaces over 100mm but not exceeding 200mm girth	LM	3,199		
	<u>Prepare Knot, prime, stop and apply one undercoat and two finishing coats first grade timber quality paint to wood surfaces as per the manufacturer's printed instructions</u>				
C	General timber surfaces	SM	1,867		
D	Surfaces over 200mm but not exceeding 300mm girth	LM	3,199		
E	Architraves: not exceeding 100 mm girth	LM	2,965		
F	Quadrant beading : not exceeding 100 mm girth	LM	2,965		
	<b>Ironmongery</b>				
	<b>Supply and fix the following ironmongery to timber complete with matching screws and keys to the approval of the Architect</b>				
G	100mm pressed steel Butt Hinges	PRS	815		
H	Stainless steel 3 Lever Mortice Door Lock with handle furniture set;( keyhole escutcheons, cylinder and latch )	NO	343		
I	Ditto: but 2 Lever Door Lock with handle	NO	200		
J	Door fixing cramps	NO	543		
K	200 x 75 x 3mm perspex door signage with door numbers as per Architect detail	NO	-		
L	Block sign with block type, name and number in exterior quality paint as per Architect detail	NO	-		
	<b>Carried to Collection</b>				
	<b>COLLECTION</b>				
	Total brought forward from page no:				
	Total brought forward from page no:				
	<b><u>ELEMENT NO. 5</u></b>	<b>Carried to</b>			
	<b><u>DOORS</u></b>	<b>Main summary</b>			

Item	Description	Unit	QTY	Rate	Amount
	<b>PROPOSED APARTMENTS FOR AFFORDABLE HOUSING PROGRAM (TYPE B G+9)</b>				
	<b>BILL NO.1-BUILDERS WORKS</b>				
	<b>ELEMENT NO 6 - EXTERNAL FINISHES</b>				
	<b>EXTERNAL WALL FINISHES</b>				
	<b>External Render</b>				
	<i>Cement and sand (1:3) render:wood floated: on concrete or blockwork: to</i>				
A	15mm thick to beams, Columns, Slab Moulds and walling externally	SM	5,332		
B	Extra over horizontal and vertical pointing in 10mm thick rod in cement and sand mix (1:3) mortar including one coat Bituminous paint	SM	-		
	<b>External Painting</b>				
	<i>Prepare and apply one coat Alkali Resistant primer followed by two finishing coats of silicon exterior Emulsion paint in accordance with the manufacturers written instructions and to the satisfaction of the architect to</i>				
C	Concrete/masonry surfaces externally-Beam, Column and Slab Moulds	SM	5,332		
	<b>ROOF FINISHES</b>				
	<b>Cement and sand (1:3) screeded beds: on concrete: complete with coloured pigmentation additives and hardener to:</b>				
D	50mm average waterproofed lightweight screed laid to falls and crossfalls to roof slabs -upper roof including gutter bases	SM	720		
	<i>Prepare and apply to vertical/horizontal surfaces 4mm thick APP/EPDM water proofing or other equal and approved membrane with surface finish weighing 4kg/sm; laid on primer with torch-on process ;by an approved specialist all in accordance with the manufacturers instructions including provision of a written ten (10) year anti leak quarantee.</i>				
E	4mm thick APP membrane applied to roof slabs	SM	720		
F	Ditto to skirting 200mm high	LM	186		
G	Dress membrane around 100mm rainwater outlet	No.	12		
	<i>The Following Flat roof concrete tiles fixed with approved adhesive, laid and jointed with waterproofing bituminous compound</i>				
H	20mm thick interlocking Concrete tiles of size 225 x 225mm with and including cement sand (1:4) backing to falls	SM	720		
	<b>ELEMENT NO. 6 Carried to</b>				
	<b>EXTERNAL FINISHES Main summary</b>				

Item	Description	Unit	QTY	Rate	Amount
<b>PROPOSED APARTMENTS FOR AFFORDABLE HOUSING PROGRAM (TYPE B G+9)</b>					
<b>BILL NO.1-BUILDERS WORKS</b>					
<b>ELEMENT NO 7 - INTERNAL FINISHES</b>					
<b><u>Internal Wall Finishes</u></b>					
<u>Cement and sand (1:3) backings</u>					
A	15mm thick to receive ceramic Wall tiles	SM	2,647		
B	To receive ceramic wall tiles (m.s.) (Lift Lobby)	SM	141		
<u>Ceramic wall tiles</u>					
<u>Allow a Prime Cost supply rate of Ksh. 1000 per SM (Rate to include cost of purchase, transport, offload, storage, fixing including all necessary adhesives and accessories</u>					
C	Supply and Fix approved ceramic wall tiles on prepared backings(m.s) with proprietary adhesive; jointed and pointed in matching coloured proprietary grouting: including pvc spacers and expansion joint as necessary: all to Architect's approval. - Wall Surfaces	SM	2,647		
<u>Porcelain wall tiles</u>					
<u>Allow a Prime Cost supply rate of Ksh. 1500 per SM (Rate to include cost of purchase, transport, offload, storage, fixing including all necessary adhesives and accessories</u>					
D	Supply and Fix porcelain wall tiles on prepared backings(m.s) with proprietary adhesive; jointed and pointed in matching coloured proprietary grouting: including pvc spacers and expansion joint as necessary: all to Architect's approval. - Wall Surfaces	SM	141		
<u>15mm (minimum) two coat cement, sand (1:3) plaster complete with wire gauze anti-crack mechanism at the intersection of masonry walling and concrete beams as described to:-</u>					
F	Concrete/masonry surfaces	SM	12,882		
<b><u>Painting and Decoration</u></b>					
<u>Prepare, Skim and apply Emulsion or universal undercoat followed by two finishing coats of soft satin Emulsion paint in accordance with the manufacturers written instructions and to the satisfaction of the architect to</u>					
G	Plastered concrete/masonry surfaces internally	SM	12,882		
<b>Carried to Collection</b>					

Item	Description	Unit	QTY	Rate	Amount
	<b><u>Floor Finishes</u></b>				
	<u>Cement and sand (1:3) screeds, backings, beds etc</u>				
A	32mm bed finished to receive Floor Tiles (m.s)	SM	5,074		
	<u>Cement and sand (1:3) backings etc</u>				
B	32mm bed finished to receive ceramic tiles to surfaces of Landings (m.s)	SM	101		
C	25 x 300 mm wide treads to receive ceramic tiles (m.s)	LM	437		
D	20 x 150mm risers to receive ceramic tiles (m.s)	LM	460		
	<u>Ceramic Floor tiles</u>				
	<u>Allow a Prime Cost supply rate of Ksh. 1000 per SM (Rate to include cost of purchase, transport, offload, storage, fixing including all necessary adhesives and accessories</u>				
E	Supply and Fix Ceramic tiles, on prepared bed(m.s) with proprietary adhesive; jointed and pointed in matching coloured proprietary grouting; including pvc spacers and expansion joint as necessary: all to Architect's approval.	SM	2,689		
F	Ditto Non Slip Ceramic Tiles	SM	2,385		
G	Ditto 100mm wide Wall Skirtings	LM	7,535		
H	Non Slip Ceramic Tiles to surfaces of Landings	SM	101		
J	Non Slip Ceramic Tiles to 300 mm wide treads	LM	437		
K	Non Slip Ceramic Tiles to 150mm risers	LM	460		
	<u>Wet areas waterproofing - Kitchens, Toilets etc.</u>				
	Liquid membrane - High build bitumen/ rubber latex emulsion with excellent adhesion, liquid applied to form a seamless flexible water proof/ vapour proof membrane as <b>as per the manufacturer's printed instructions to; solid content =65%, Rubber Content=10% in dried film</b>				
L	To floors and walls	SM	2,385		
	<b>Staircase soffit finishes</b>				
	<u>15mm (minimum) two coat cement, sand (1:3) plaster complete with wire gauze anti-crack mechanism at the intersection of masonry walling and concrete beams as described to:-</u>				
M	Soffits of staircase landing	SM	101		
N	Ditto to sloping soffites exceeding 15° from horizontal	SM	154		
P	Staircase string 300mm extreme girth and cut to profile of steps	LM	268		
	<b>Paint works</b>				
	<u>Prepare, skim and apply Emulsion or universal undercoat followed by two finishing coats of soft satin Emulsion paint in accordance with the manufacturers written instructions and to the satisfaction of the architect to</u>				
Q	Soffits of staircase landing	SM	101		
R	Ditto to sloping soffites exceeding 15° from horizontal	SM	154		
S	Staircase string 300mm extreme girth and cut to profile of steps	LM	268		
	<b>Carried to Collection</b>				



Item	Description	Unit	QTY	Rate	Amount
	<p><b><u>Ceiling finishes</u></b></p> <p><u>15mm (minimum) two coat cement, sand (1:3) plaster complete with wire gauze anti-crack mechanism at the intersection of masonry walling and concrete beams as described to:-</u></p>				
A	Soffits of Concrete surfaces	SM	6,782		
	<u>Painting and Decoration</u>				
	<u>Prepare, skim and apply Emulsion or universal undercoat followed by two</u>				
	<u>finishing coats of soft satin Emulsion paint in accordance with the manufacturers</u>				
	<u>written instructions and to the satisfaction of the architect to</u>				
B	Plastered ceilings	SM	6,782		
	<b>Carried to Collection</b>				

Item	Description	Unit	QTY	Rate	Amount
	<b>COLLECTION</b>				
	Total brought forward from page no:				
	Total brought forward from page no:				
	Total brought forward from page no:				
	<b>ELEMENT NO. 7</b>				
	<b>INTERNAL FINISHES</b>				
	<b>Carried to</b>				

Item	Description	Unit	QTY	Rate	Amount
	<p align="center"><b>PROPOSED APARTMENTS FOR AFFORDABLE HOUSING PROGRAM (TYPE B G+9)</b></p> <p align="center"><b>BILL NO.1-BUILDERS WORKS</b></p> <p><b>ELEMENT NO 8- BALUSTRADING AND RAILING</b></p> <p><u>Balustrades and staircase railings</u></p> <p>A 900mm high mild Steel balustrade; comprising 60 x 10mm mild Steel balusters at 900mm centres; bolted to base plate and tread (m.s), with 7No. 25mm diameter horizontal bars, and 75x4mm diameter CHS mild Steel handrail part welded into 60x10mm balustrades; to Architects drawings</p> <p>B 50mm diameter x 3mm CHS handrail supported by 50 x 50 x 3mm thick SHS balusters anchored to slab with and including w/steel bolts and plates at 1800mm centres smooth welded 100mm high (Staircase)</p> <p><u>Prepare, prime and apply one undercoat and two finishing coats first quality gloss oil paint on</u></p> <p>C General metal surfaces of balustrading (both sides measured overall)</p>	LM	82		
	<p><b>ELEMENT NO. 8</b> Carried to the</p> <p><b>BALUSTRADE AND RAILING</b> Main summary</p>				





Item	Description	Unit	QTY	Rate	Amount
	<b>PROPOSED APARTMENTS FOR AFFORDABLE HOUSING PROGRAM (TYPE B G+9)</b>				
	<b>BILL NO.1-BUILDERS WORKS MAIN SUMMARY</b>				
1	Substructures				
2	Reinforced Concrete Frame				
3	Walling				
4	Windows				
5	Doors				
6	External Finishes				
7	Internal Finishes				
8	Balustrade and Railing				
9	Joinery and Fittings				
10	Builders Works				
	<b><u>TOTAL FOR 1NO. TYPE B (G+9) BLOCK</u></b>				
	MULTIPLY BY <b>8.NO</b> OF BLOCKS	<b>X 8</b>			8.00
	<b><u>TOTAL FOR TYPE B (G+9) BLOCK(S) CARRIED TO GRAND SUMMARY</u></b>				

**CLUB HOUSE**

ITEM	DESCRIPTION	UNIT	QTY	RATE	AMOUNT
	<p><b><u>PROPOSED CLUB HOUSE</u></b></p> <p><b>BILL NO.1 BUILDERS WORKS</b></p> <p><b>ELEMENT NO 1 - SUBSTRUCTURES (ALL PROVISIONAL)</b></p> <p><b>Excavations including trimming sides and bottoms of excavations; maintaining and supporting sides; and keeping free from water, mud and fallen material; with and including destruction of termites nests within site of works, take out and destroy queens, imp</b></p> <p><i>Site Clearance</i></p>				
A	Clear site of all grass, hedges, shrubs, bushes grub up roots, load and remove from site and dispose at designated local authority areas.	SM	418		
B	Bulk excavation to reduce levels depth not exceeding 1.5m commencing from existing ground level	CM	627		
C	Excavate for Strip foundations depth not exceeding 1.50 metres starting from Stripped level	CM	67		
D	Excavate for column bases depth not exceeding 1.5m starting from reduced Levels	CM	41		
E	Extra over all type of excavation for excavating in soft rock	CM	5		
F	Ditto excavation in hard rock class I	CM	5		
	<b>Disposal of water</b>				
G	Allow for keeping the whole of the excavation free from all spring and running water by pumping or any other such means as may be necessary	Item			
	<b>Planking and strutting</b>				
H	Allow for maintaining and upholding the sides of excavations and keeping excavations clear of all fallen materials, rubbish etc	Item			
	<b>Carried to collection</b>				



ITEM	DESCRIPTION	UNIT	QTY	RATE	AMOUNT
	<b><u>Disposal of excavated material</u></b>				
A	Return, fill and ram selected excavated material around foundations.	CM	589		
B	Load,wheel and cart away surplus excavated material away from site	CM	147		
	<b>Fillings</b>				
C	Make up levels using approved imported materials: compacted in layers not exceeding 300mm thick with a 15ton roller: to the satisfaction of the Structural Engineer.	CM	373		
D	300mm thick hardcore bed: hand packed : compacted in layers not exceeding 150mm thick: to the satisfaction of the Structural Engineer: including 50mm Thick murrum or "equal and approved" blinding to surfaces of hardcore	SM	418		
E	50 mm Thick Murrum Blinding to surfaces of hadcore <b>Anti - termite to treatment</b>	SM	418		
F	Approved anti-termite treatment, with ten-year guarantee, sprayed to surfaces of hardcore strictly in accordance with manufacturer's instructions.	SM	418		
	<b>Damp-proof membrane</b>				
G	1000 gauge polythene or other equal and approved damp-proof membrane, laid over blinded hardcore (measured separately) with 300mm side and end laps (measured nett-allow for laps); 1 No. layer: bedded in and including cement and sand (1:3) mortar	SM	418		
	<b>Concrete Blinding</b>				
	<b>Insitu concrete Class 15MPa: vibrated:</b>				
H	50 mm Thick under column bases	SM	83		
I	Ditto strip foundation	SM	57		
	<b>In- situ vibrated reinforced concrete Class 25MPa: in:</b>				
J	Column bases	CM	35		
K	Columns	CM	5		
L	Strip foundation	CM	11		
M	100mm thick surface bed	SM	418		
N	Ground beams	CM	7		
O	Concrete steps & Staircase footing	CM	7		
	<b>Carried to collection</b>				

ITEM	DESCRIPTION	UNIT	QTY	RATE	AMOUNT
	<b>Ribbed reinforcement steel bars to KS 573:2014 : Grade 500 high tensile strength including bends, hooks, tying wire and distance blocks; to S.E's detail ( Provisional)</b>				
A	Assorted reinforcement	Kg	5540		
	<b>Mesh fabric reinforcement to KS/EAS 412;2 (2019) BRC A142;200 x 200mm, weighing 2.22kg/m<sup>2</sup> (measured net - no allowance) for laps; in two layers - top &amp; bottom; including bends, tying wire and spacer blocks)</b>				
B	In Surface floor bed	SM	418		
	<u>Modular steel frame with steel plates covering formwork and/or marine board formwork: to:</u>				
C	Sides of column bases	SM	82		
D	Ditto strip footing	SM	38		
E	Vertical sides of columns	SM	136		
F	Edge of slab, over 150mm but not exceeding 225mm girth	LM	137		
G	Ditto; but to edges of risers	LM	98		
H	Vertical sides to ground beams	SM	65		
	<b>Foundation Walling</b>				
	<b>Natural quarry stone walling with a minimum of 7.0 N/mm<sup>2</sup> bedded and jointed in cement and sand (1:4) mortar, reinforced with and including 25 x 3 mm thick hoop iron strips at every alternate course as described in;</b>				
I	200mm thick walls in foundations	SM	296		
	<b><u>Pavings</u></b>				
J	Supply and lay 600 x 600 x 50mm reinforced concrete precast paving slabs around the building including laying, spreading and compacting 100mm thick approved sand bed blinding, on and including 150mm thick compacted hardcore to Engineer's approval.	SM	82		
	<b><u>Plinth</u></b>				
	<b><u>25mm Thick cement and sand (1:3) rendering on concrete or masonry ; wood float finished; to</u></b>				
K	Plinths externally	SM	62		
	<b>Two coats black bitumastic paint on:</b>				
L	Rendered surfaces	SM	62		
	<b>Planters</b>				
M	200mm thick masonry planter walls complete with foundations	LM	44		
	<b>Carried to collection</b>				

ITEM	DESCRIPTION	UNIT	QTY	RATE	AMOUNT
	<b>COLLECTION</b>				
	Total brought forward from page no:1				
	Total brought forward from page no:2				
	Total brought forward from page no:3				
	<b>ELEMENT NO. 1</b>				
	<b>SUBSTRUCTURES</b>				
	Carried to Main summary				

ITEM	DESCRIPTION	UNIT	QTY	RATE	AMOUNT
<b>PROPOSED CLUB HOUSE</b>					
<b>BILL NO.1-BUILDERS WORKS</b>					
<b>ELEMENT No 2 - R.C FRAME</b>					
<i>In situ concrete class 25MPa: vibrated: reinforced</i>					
A	Columns	CM	20		
B	Ring beam	CM	27		
C	150mm thick Ramp	SM	20		
D	150mm Thick suspended horizontal slab	SM	518		
E	175mm Thick suspended horizontal slab	SM	108		
F	150 mm thick landing	SM	8		
G	Staircases	CM	5		
H	200 x 200 x 225mm decorative concrete/plaster moulds with approved reinforcement mesh/bars	LM	242		
<b>Ribbed reinforcement steel bars to KS 573:2014 : Grade 500 high tensile strength including bends, hooks, tying wire and distance blocks; to S.E's detail ( Provisional)</b>					
I	Assorted reinforcement bars	Kg	15856		
<i>Modular steel frame with steel plates covering formwork and/or marine board formwork: to</i>					
J	Sides and soffites of beams	Sm	270		
K	To vertical sides of columns	SM	294		
L	Edges of steps not exceeding 150mm girth	LM	1		
M	Soffits of suspended slabs	SM	627		
N	Edges of slab over 150mm but not exceeding 225mm girth	LM	242		
O	To sloping soffites of staircases	SM	19		
P	Soffits of landings	SM	8		
Q	Riser of steps over 150 mm but not exceeding 225 mm girth	LM	64		
R	Staircase string 300mm extreme girth and cut to profile of steps	LM	28		
S	Edges of landing over 150 but ot exceeding 225mm high	LM	11		
	<b>ELEMENT NO. 2</b>	<b>Carried to</b>			
	<b>R.C FRAME</b>	<b>Main summary</b>			

ITEM	DESCRIPTION	UNIT	QTY	RATE	AMOUNT
<b>PROPOSED CLUB HOUSE</b>					
<b>BILL NO.1-BUILDERS WORKS</b>					
<b>ELEMENT No 3-WALLING</b>					
<b><u>WALLING</u></b>					
<b>External Walling</b>					
<i>Machine cut quarry stone walling with a minimum of 7.0 N/mm<sup>2</sup> average compressive strength;bedded and jointed in cement and sand (1:4) mortar, reinforced with and including 25 x 3 mm thick hoop iron strips at every alternate course as described in;</i>					
A	200mm thick walling Externally	Sm	307		
B	200mm thick parapet walling	Sm	104		
C	400mm thick walling Externally	Sm	344		
D	Leave 150 x 600mm high openings in parapet walls and make good edges and reveals to Architect's approval	No	100		
E	200 x 200 x 225mm wide façade features / moulds to Architect's approval	No	100		
<b><u>Internal Walling</u></b>					
<i>Machine cut quarry stone walling with a minimum of 7.0 N/mm<sup>2</sup> average compressive strength;bedded and jointed in cement and sand (1:4) mortar, reinforced with and including 25 x 3 mm thick hoop iron strips at every alternate course as described in;</i>					
F	200mm thick walling	Sm	348		
G	150mm thick walling	Sm	262		
H	Approved hessian based damp proof course to 200mm thick walling in cement/sand mortar	Lm	28		
I	Ditto to 400mm thick walling	Lm	81		
J	Ditto to 150mm thick walling	Lm	47		
<b><u>Lintols</u></b>					
K	100mm x 200mm Deep lintols in reinforced concrete class 20MPa with and including 4No T10 and T8 stirups at 200mm centres; complete with formwork	Lm	105		
<b><u>Coping</u></b>					
L	300 x 100mm insitu reinforced concrete class 20Mpa coping, throated and weathered and jointing to columns with cement sand 1:4 mortar	Lm	122		
<b><u>Pergola</u></b>					
M	Supply and fix Pergolla in 150x50x4mm thick RHS members spaced at 200mm c/c complete with 100x100x5mm thick SHS posts bolted to concrete foundations to details; apply 3coats of paint to steel members	SM	22		
<b><u>ELEMENT NO. 3</u></b>		<b>Carried to</b>			
<b><u>WALLING</u></b>		<b>Main summary</b>			

ITEM	DESCRIPTION	UNIT	QTY	RATE	AMOUNT
	<b><u>PROPOSED CLUB HOUSE</u></b>  <b>BILL NO.1-BUILDERS WORKS</b>  <b>ELEMENT NO 4-WINDOWS</b>  <b><u>METAL WORK</u></b>  <b><u>PURPOSE - MADE UNITS</u></b>  <b>Supply, fabricate and fix the following purpose made small pane mild steel casement windows to be fabricated from approved mild steel sections (atleast 14g 2mm thick ) comprising of frame and casement incorporating permanent hooded high level ventilation panels infilled with mosquito gauze : window supplied complete with and including 12mm solid square burglar proofing bars fixed at 200mm centres both ways and metal fixing lugs including building into wall and making good, and all necessary iron mongery viz hinges, fasteners, and hasp including shop priming window with red oxide primer before delivery to site:-</b>  <b>A prime cost sum of Kshs 4,500 per Sqm has been allowed for fabrication of the above specified Steel casement Windows by AHP juakali artisans as approved by the Project Manager/Architect.</b>  <b>The contractor's unit rate shall include the cost of transport, storage, fixing and all associated accesories in addition to the PC Rate.</b>				
A	Window, overall size 1800 X 2300mm high to Architects Details	NO	23		
B	Ditto Size 900 x 2300mm high	NO	4		
C	Ditto Size 800 x 2300mm high	NO	3		
	<b><u>Glazing</u></b>				
D	4mm Thick clear sheet glass panes over 0.1 but not exceeding 0.5 square meters; fixing with premium putty	SM	101		
E	Ditto; obscure	SM	8		
	<b><u>Painting and Decorations</u></b>				
	<b><u>On Metal work</u></b>				
	<b><u>Prepare and apply aerosol spray painting in two finishing coats of first grade paint as per the manufacturer's printed instructions to: -</u></b>				
F	General window and grille surfaces	SM	218		
	<b>Carried to Collection</b>				

ITEM	DESCRIPTION	UNIT	QTY	RATE	AMOUNT
	<b><u>Precast concrete window cill finishing fair on all exposed surfaces and hoisting and placing in position, bedding, jointing and pointing in pigmented cement and sand (1:3) mortar</u></b>				
A	150 x 25mm thick precast concrete window sill	LM	49		
	<b>Window board</b>				
B	150mm wide x 25mm thick window board in softwood timber plugged to the wall	LM	49		
	<b>Prepare and apply one coat first quality aluminium wood primer before fixing: on wood: to</b>				
C	Surfaces exceeding 100mm but not exceeding 200 mm girth	LM	49		
	<b>Prepare and apply three coats of first quality polyurethane clear varnish: on wood: to</b>				
D	Window board: surfaces exceeding 100mm but not exceeding 200 mm girth	LM	49		
	<b><u>Curtain rods:</u></b>				
B	1.5mm thick, 20mm thick diameter twin powdercoated mild steel rod complete accessories to approval	LM	80		
	<b>Carried to collection</b>				
	<b>COLLECTION</b>				
	Total brought forward from page no:				
	Total brought forward from page no:				
	<b><u>ELEMENT NO. 4</u></b> <b><u>WINDOWS</u></b>	<b>Carried to the</b> <b>Main summary</b>			

ITEM	DESCRIPTION	UNIT	QTY	RATE	AMOUNT
	<b><u>PROPOSED CLUB HOUSE</u></b>				
	<b>BILL NO.1-BUILDERS WORKS</b>				
	<b>ELEMENT NO 5-DOORS</b>				
	<b><u>External Doors</u></b>				
	<b><u>Glazed mild steel casement sliding doors</u></b>				
	<b>Heavy gauge purpose made mild steel door comprising 40 x 25 x3mm stiles, top and bottom stiles, 4 No Intermediate rails, 1.5mm steel sheet both sides welded in place and 5mm thick clear glazing, all primed with red oxide and spray painted with 2 coats of first quality gloss oil paint; complete with hinges, stays, 5lever locks, sliding gear, fasteners and necessary seremetals assembled and fixed to opening including cutting and pinning lugs to concrete or block work surround and bedding frame in cement and sand mortar (1:3).</b>				
A	Double Sliding Door overall size 1800 x 2850mm high	NO	10		
B	Bifold door Size 3000 x 2850mm high	NO	1		
	<b><u>Internal Doors</u></b>				
	<b>Flush timber doors</b>				
	<b>50 mm thick Solid cored flush doors with plywood facing to receive painting (m.s) all to Architects details, specifications and approval</b>				
C	Door size 900mm x 2100mm high comprising of 1 No opennable leaf size 800 x 2100mm high	NO	13		
D	Ditto Size 800 x 2100mm high comprising of 1 No opennable leaf size 700 x 2100mm high	NO	12		
E	Ditto Size 1000 x 2100mm high comprising of 1 No opennable leaf size 900 x 2100mm high	NO	4		
	<b>50mm thick approved hardwood PANEL doors with 12.5mm thick Mahogany hardwood lipping to Architect's details, specifications and approval</b>				
	<b>A prime cost sum at the rate indicated below has been allowed for fabrication of the above specified Hardwood panelled door leaves by AHP juakali artisans as approved by the Project Manager/Architect.</b>				
	<b>The contractor's unit rate shall include the cost of transport, storage, fixing and all associated accesories in addition to the PC Rate.</b>				
	Door size 1800 x 2400mm high ( PC Rate Kshs 49,200)	NO	2		
	<i>Frames and frame finishes in mahogany timber:</i>				
F	25 x 25mm quadrant beading (PC Rate Kshs 75)	LM	172		
G	25 x 50mm architrave with two labours, plugged (PC Rate Kshs 150)	LM	172		
H	150mm x 50mm frame with three labours; chamfered edges; plugged (PC Rate Kshs 1400)	LM	172		
	<b>Carried to collection</b>				



ITEM	DESCRIPTION	UNIT	QTY	RATE	AMOUNT
	<u>Painting and decorating</u>				
	<u>Prepare and apply one coat aluminium wood primer to:-</u>				
A	Surfaces not exceeding 100mm girth	LM	343		
B	Surfaces over 100mm but not exceeding 200mm girth	LM	172		
	<u>Prepare Knot, prime, stop and apply one undercoat and two finishing coats first grade timber quality paint to wood surfaces as per the manufacturer's printed instructions</u>				
C	General timber surfaces	SM	124		
D	Surfaces not exceeding 100mm girth	LM	343		
E	Surfaces over 100mm but not exceeding 200mm girth	LM	172		
	<u>Prepare, prime and apply one undercoat and two finishing coats first quality gloss oil paint on as per the manufacturer's printed instructions to:-</u>				
F	General surfaces of metal doors	SM	120		
	<b>Ironmongery</b>				
	<b>Supply and fix the following ironmongery to timber complete with matching screws and keys to the approval of the Architect</b>				
G	100mm pressed heavy duty steel Butt Hinges	Pairs	50		
H	3 Lever Door Lock with handles as per Union	NO	31		
I	Door fixing cramps	NO	198		
J	Approved male/female signage	NO	4		
	<b>Carried to Collection</b>				
	<b>COLLECTION</b>				
	Total brought forward from page no:				
	Total brought forward from page no:				
	<b>ELEMENT NO. 5</b>	<b>Carried to</b>			
	<b>DOORS</b>	<b>Main summary</b>			

ITEM	DESCRIPTION	UNIT	QTY	RATE	AMOUNT
<b>PROPOSED CLUB HOUSE</b>					
<b>BILL NO.1-BUILDERS WORKS</b>					
<b>ELEMENT NO 6 - EXTERNAL FINISHES</b>					
<b>EXTERNAL WALL FINISHES</b>					
<b>External Render</b>					
<i>Cement and sand (1:3) render:wood floated: on concrete or blockwork: to</i>					
A	15mm thick to parapet walling externally	SM	754		
B	Ditto to surfaces of beams and columns	SM	256		
C	Extra over vertical and horizonatal key pointing in 10 mm rod in cement and sand mix (1:3) mortar including one coat of Bituminous paint	SM	50		
<b>External Painting</b>					
<i>Prepare and apply one coat Alkali Resistant primer followed by two finishing coats of silicon exterior Emulsion paint in accordance with the manufacturers written instructions and to the satisfaction of the architect to</i>					
D	Masonry surfaces externally-Beam, Column and Slab Moulds	SM	754		
E	Ditto to surfaces of beams and columns	SM	256		
<b>FLAT ROOF FINISHES</b>					
<b>Cement and sand (1:4) screeded beds: on concrete: complete with coloured pigmentation additives and hardener to:</b>					
F	50mm average waterproofed lightweight screed laid to falls and crossfalls to roof slabs -upper roof including gutter bases	SM	246		
<i>Prepare and apply to vertical/horizontal surfaces 4mm thick APP/EPDM water proofing or other equal and approved membrane with surface finish weighing 4kg/sm; laid on primer with torch-on process ;by an approved specialist all in accordance with the manufacturers instructions including provision of a written ten (10) year anti leak guarantee.</i>					
G	4mm thick APP membrane applied to roof slabs	SM	246		
H	Ditto to skirting 200mm high	LM	166		
I	Dress membrane around 100mm rainwater outlet	No.	18		
<i>The Following Flat roof concrete tiles fixed with approved adhesive, laid and jointed with waterproofing bituminous compound</i>					
J	20mm thick interlocking Concrete tiles of size 225 x 225mm	SM	275		
<b>ELEMENT NO. 6</b>		<b>Carried to</b>			
<b>EXTERNAL FINISHES</b>		<b>Main summary</b>			

ITEM	DESCRIPTION	UNIT	QTY	RATE	AMOUNT
	<b><u>PROPOSED CLUB HOUSE</u></b>				
	<b>BILL NO.1-BUILDERS WORKS</b>				
	<b>ELEMENT NO 7 - INTERNAL FINISHES</b>				
	<b><u>Internal Wall Finishes</u></b>				
	<u>15 mm thick Cement and sand (1:3) backings on blockwork to receive ceramic wall tiles:to:</u>				
A	Internal wall surfaces- Wet areas  <u>Ceramic wall tiles</u>  <u>Allow a Prime Cost supply rate of Ksh. 1000 per SM (Rate to include cost of purchase, transport, offload, storage, fixing including all necessary adhesives and accessories</u>	SM	289		
B	Supply and Fix approved ceramic wall tiles on prepared backings(m.s) with proprietary adhesive; jointed and pointed in matching coloured proprietary grouting: including pvc spacers and expansion joint as necessary: all to Architect's approval. - Wall Surfaces  <u>15mm (minimum) two coat cement, sand (1:3) plaster complete with wire gauze anti-crack mechanism at the intersection of masonry walling and concrete beams as described to:-</u>	SM	289		
C	Concrete/masonry surfaces <b>Internally</b>	SM	1684		
D	Ditto to window cills, door Jambs Externally and Surfaces not exceeding 200mm girth	LM	147		
	<b><u>Painting and Decoration</u></b>				
	<u>Prepare, Skim and apply Emulsion or universal undercoat followed by two finishing coats of soft satin Emulsion paint in accordance with the manufacturers written instructions and to the satisfaction of the architect to</u>				
E	Plastered concrete/masonry surface	SM	1684		
F	Ditto to window cills, door Jambs Externally and Surfaces not exceeding 200mm girth	LM	147		
	<b>Carried to Collection</b>				

ITEM	DESCRIPTION	UNIT	QTY	RATE	AMOUNT
	<b><u>Floor Finishes</u></b>				
	<b><u>32 mm thick Cement and sand (1:3) backing on concrete surfaces,prepared to receive approved floor finish to:</u></b>				
A	Receive ceramic floor tiles	SM	44		
B	Receive ceramic floor tiles	SM	574		
C	300 mm wide treads of steps	LM	97		
D	150mm high risers of steps	LM	98		
E	Receive rubber flooring	SM	86		
F	Receive timber flooring	SM	32		
	<b><u>Ceramic Floor tiles</u></b>				
	<i>Allow a Prime Cost supply rate of Ksh. 1000 per SM (Rate to include cost of purchase, transport, offload, storage, fixing including all necessary adhesives and accessories</i>				
	Supply and Fix Ceramic tiles, on prepared bed(m.s) with proprietary adhesive; jointed and pointed in matching coloured proprietary grouting; including pvc spacers and expansion joint as necessary: all to Architect's approval.				
G	Floor Surfaces	SM	44		
H	Ditto 100mm wide Wall Skirtings	LM	80		
	<b><u>Porcelain Floor tiles</u></b>				
	<i>Allow a Prime Cost supply rate of Ksh. 1500 per SM (Rate to include cost of purchase, transport, offload, storage, fixing including all necessary adhesives and accessories</i>				
	Supply and Fix porcelain wall tiles on prepared backings(m.s) with proprietary adhesive; jointed and pointed in matching coloured proprietary grouting; including pvc spacers and expansion joint as necessary: all to Architect's approval. - Wall Surfaces				
I	Floor Surfaces	SM	574		
J	Ditto 100mm wide Wall Skirtings	LM	566		
	<b><u>Timber Floor Finish</u></b>				
	<b><u>Supply and Fix approved mahogany timber flooring; with approved glue ; varnish to approval ; secret nailing : on backing screeds with timber strips (m.s.) :- all to Architect's approval:to:</u></b>				
K	Floor Surfaces	SM	32		
L	Ditto 100mm wide Wall Skirtings	LM	25		
	<b>Carried to Collection</b>				

ITEM	DESCRIPTION	UNIT	QTY	RATE	AMOUNT
	<u>Rubber Floor Tiles</u> Supply and Fix approved Rubber Floor Tiles; bedded and jointed in matching coloured proprietary grout on prepared on prepared backings(m.s); : including pvc spacers and expansion joint as necessary: all to Architect's approval:to:				
A	Floor Surfaces	SM	86		
B	Ditto 100mm wide Wall Skirtings	LM	38		
	<b>Staircase finishes</b>  <b><u>32 mm thick Cement and sand (1:3) backing on concrete surfaces,prepared to receive ceramic floor tiles to:</u></b>				
C	300 mm wide treads of steps	LM	59		
D	150mm high risers of steps	LM	64		
E	Landing <u>Ceramic staircase tiles</u>  <i>Allow a Prime Cost supply rate of Ksh. 1500 per SM (Rate to include cost of purchase, transport, offload, storage, fixing including all necessary adhesives and accessories</i> Supply and Fix ceramic wall tiles on prepared backings(m.s) with proprietary adhesive; jointed and pointed in matching coloured proprietary grouting: including pvc spacers and expansion joint as necessary: all to Architect's approval. - Wall Surfaces	SM	8		
F	300 mm wide treads of steps	LM	59		
G	150mm high risers of steps	LM	64		
E	Landing  <u>15mm (minimum) two coat cement, sand (1:3) plaster complete with wire gauze anti-crack mechanism at the intersection of masonry walling and concrete beams as described to:-</u>	SM	8		
H	Soffits of staircase landing	SM	8		
I	Ditto to sloping soffites exceeding 15° from horizontal	SM	19		
J	Staircase string 300mm extreme girth and cut to profile of steps	LM	28		
	<b><u>Paint works</u></b> <u>Prepare, Skim and apply Emulsion or universal undercoat followed by two finishing coats of soft satin Emulsion paint in accordance with the manufacturers written instructions and to the satisfaction of the architect to</u>				
K	Soffits of staircase landing	SM	8		
L	Ditto to sloping soffites exceeding 15° from horizontal	SM	19		
M	Staircase string 300mm extreme girth and cut to profile of steps	LM	28		
	<b>Carried to Collection</b>				

ITEM	DESCRIPTION	UNIT	QTY	RATE	AMOUNT
	<b><u>Ceiling finishes</u></b>				
	<u>15mm (minimum) two coat cement, sand (1:3) plaster complete with wire gauze anti-crack mechanism at the intersection of masonry walling and concrete beams as described to:-</u>				
A	Soffits of Concrete surfaces	SM	627		
	<b><u>Painting and Decoration</u></b>				
	<u>Prepare, Skim and apply Emulsion or universal undercoat followed by two finishing coats of soft satin Emulsion paint in accordance with the manufacturers written instructions and to the satisfaction of the architect to</u>				
B	Plastered ceilings	SM	627		
	<b><u>Gypsum boards</u></b>				
	12.5mm approved Moisture resistant Suspended gypsum plasterboard ceiling : on and including pressed 50 x 50mm aluminium suspended brading system at 600mm centres both ways with brading end trims as specified : allow for all necessary timber stiffener or bearers where directed: allow end trims as directed including all cutting and trimming to light fittings, or other equipments as required (all quantities measured flat overall over light fittings): allow for all vertical and horizontal trims: allow where necessary for welded mild steel supports complete with bolts and welded connections :fixing with self tapping screws; taped and filled joints : complete with Modified pre-formed polyurethane decorative mouldings and cornices : including 50 x 50mm shadow gap between wall and gypsum ceiling and; 15 x 15mm shadow gap between grid and gypsum ceiling; all to Architect's details and patterns	SM	350		
D	100 x 20mm gypsum cornice with two labours	LM	189		
	<u>Prepare, Skim and apply Emulsion or universal undercoat followed by two finishing coats of soft satin Emulsion paint in accordance with the manufacturers written instructions and to the satisfaction of the architect to</u>				
E	Gypsum ceilings	SM	350		
F	Ditto cornice	LM	189		
	<b>Carried to Collection</b>				

ITEM	DESCRIPTION	UNIT	QTY	RATE	AMOUNT
	<b>COLLECTION</b>				
	Total brought forward from page no:				
	Total brought forward from page no:				
	Total brought forward from page no:				
	Total brought forward from page no:				
	<b>ELEMENT NO. 7</b>				
	<b>INTERNAL FINISHES</b>				
	Carried to				

ITEM	DESCRIPTION	UNIT	QTY	RATE	AMOUNT
<b>PROPOSED CLUB HOUSE</b>					
<b>BILL NO.1-BUILDERS WORKS</b>					
<b>ELEMENT NO 8- BALUSTRADING AND RAILING</b>					
<i>Balustrades and staircase railings</i>					
A	900mm high mild Steel balustrade; comprising 60 x 10mm mild Steel balusters at 900mm centres; bolted to base plate and tread (m.s), with 7No. 25mm diameter horinzontal bars, and 75x4mm diameter CHS mild Steel handrail part welded into 60x10mm balustrades; to Architects drawings	LM	20		
<i>Prepare, prime and apply one undercoat and two finishing coats first quality gloss oil paint on</i>					
B	General metal surfaces of balustrading (both sides measured overall)	SM	49		
<b>ELEMENT NO. 8 BALUSTRADING AND RAILING Carried to the Main summary</b>					



ITEM	DESCRIPTION	UNIT	QTY	RATE	AMOUNT
<b>PROPOSED CLUB HOUSE</b>					
<b>BILL NO.1-BUILDERS WORKS</b>					
<b>ELEMENT NO 9 - ROOFING</b>					
A	<b>28 gauge IT5 Roofing sheets;</b> laid on timber structure and including fixing clips and brackets and fixing to timber rafters at 600mm centres(m/s)	SM	120		
B	Gauge 28 galvanized 450 mm Ridge cap and hip cap to match roof covering	LM	10		
C	Gauge 28 galvanized iron Ditto hip cap	LM	18		
<b>STRUCTURAL STEEL CONSTRUCTION</b>					
<b>1. Prices shall include for unloading, hoisting and fixing in position including requisite staging for erection.</b>					
<b>2. Allow for factory priming in lead oxide and touching up the priming on site later</b>					
<b>3. Prices should allow for fillet weld and welded connections</b>					
<b>The following in Steel Trusses including hoisting and fixing in position 2.8m above ground floor</b>					
D	50 x 50 x 3mm Thick SHS purlins	Kg	463		
E	50 x 50 x 3mm. Thick SHS external members	Kg	638		
F	50 x 25 x 3mm. Thick RHS internal members	Kg	765		
G	26-gauge prepainted G.I/Aluzinc box roof gutters with 100mmx75mm cross-section	LM	45		
N	Extra over rainwater gutter for 100mm diameter downpipe outlet	no	6		
O	Ditto stopped end	no	6		
P	Ditto bend	no	6		
<u>Wrot softwood Fascia board</u>					
G	250mm x 25mm Fascia/ barge boards nailed to end of rafters	LM	45		
<u>Painting Wood</u>					
<u>Knot, prime, stop and paint three coats of gloss oil paint as Crown or other equal and approved to:</u>					
H	Fascia or verge; girth 225mm - 300mm	LM	45		
<b>Carried to Collection</b>					

ITEM	DESCRIPTION	UNIT	QTY	RATE	AMOUNT
	<p><b><u>Rain water goods</u></b></p> <p><u>Supply and fix the following in UPVC: to BS 4515 with fittings fixed to manufacturer's instruction and BS 5572: manufactured by "Doshi Kenya Ltd" or other equal and approved: tenderer must allow in the pipework for pipe fixing clips or holderbats, plugged and screwed</u></p>				
A	110mm Diameter <b>down pipe:</b> Grey uPVC with and including swan neck offset and shoes: holder bats at 1500mm centres: including water-tight connections to mild steel gutters	LM	18		
B	Extra over ditto for swan neck	no	6		
C	Ditto horse shoe <b>Carried to collection</b>	no	6		
	<b>COLLECTION</b>				
	Total brought forward from page no:				
	Total brought forward from page no:				
<b>ELEMENT NO. 9 ROOFING Carried to the Main summary</b>					



ITEM	DESCRIPTION	UNIT	QTY	RATE	AMOUNT
	<b><u>PROPOSED CLUB HOUSE</u></b> <b>BILL NO.1-BUILDERS WORKS</b>  <b>MAIN SUMMARY</b>				
1	<b>Substructures</b>				
2	<b>Reinforced Concrete Frame</b>				
3	<b>Walling</b>				
4	<b>Windows</b>				
5	<b>Doors</b>				
6	<b>External Finishes</b>				
7	<b>Internal Finishes</b>				
8	<b>Balustrading and Railing</b>				
9	<b>Roofing</b>				
10	<b>Joinery fittings</b>				
	<b>TOTAL FOR CLUB HOUSE CARRIED TO GRAND SUMMARY</b>				

# **KINDERGATTEN**

Item	DESCRIPTION	Unit	QTY	Rate	Amount
	<b><u>PROPOSED KINDERGARTEN</u></b>				
	<b>BILL NO.6-BUILDERS WORKS</b>				
	<b>ELEMENT NO 1 - SUBSTRUCTURES (ALL PROVISIONAL)</b>				
	<i>Site Clearance</i>				
A	Clear site of all grass, hedges, shrubs, bushes grub up roots, load and remove from site and dispose at designated local authority areas.	SM	552		
B	Excavate average 200mm deep to remove top vegetable soil, load, remove from site and dump in designated local authority dump site.	SM	552		
C	Excavate to reduced levels in varying depths not exceeding 1.5m deep from existing ground levels.	Cm	828		
D	Ditto exceeding 1.5m deep but not exceeding 3.0m from existing reduced levels.	Cm	276		
E	Excavate for column bases foundations depth starting from Reduced ground levels.	Cm	6		
F	Excavate for Strip foundations depth starting from Reduced ground levels.	Cm	56		
G	Extra over all type of excavation for excavating in soft rock	Cm	3		
H	Ditto excavation in hard rock class I	Cm	3		
	<b>Disposal of water</b>				
I	Allow for keeping the whole of the excavation free from all spring and running water by pumping or any other such means as may be necessary	Item			
	<b>Planking and strutting</b>				
J	Allow for maintaining and upholding the sides of excavations and keeping excavations clear of all fallen materials, rubbish etc	Item			
	<b>Carried to collection</b>				

Item	DESCRIPTION	Unit	QTY	Rate	Amount
	<b><u>Disposal of excavated material</u></b>				
A	Return, fill and ram selected excavated material around foundations.	CM	202		
B	Load, wheel and cart away surplus excavated material to a Local Authority designated dumping site or fill soil heaps as away from site instructed by the Project Engineer.	CM	1,131		
	<b>Fillings</b>				
C	Make up levels using approved imported materials: compacted in layers not exceeding 300mm thick with a roller: to the satisfaction of the Structural Engineer.	CM	789		
D	300mm thick hardcore bed: hand packed : compacted in layers not exceeding 150mm thick: to the satisfaction of the Structural Engineer	SM	526		
E	Labour to form sinking in hardcore; 350mm average x 200 mm deep	LM	9		
F	50 mm Thick Murram Blinding to surfaces of hadcore	SM	526		
	<b>Anti - termite to treatment</b>				
G	Approved anti-termite treatment, with ten-year guarantee, sprayed to surfaces of hardcore strictly in accordance with manufacturer's instructions.	SM	552		
	<b>Damp-proof membrane</b>				
H	1000 gauge polythene or other equal and approved damp-proof membrane, laid over blinded hardcore (measured separately) with 300mm side and end laps (measured nett-allow for laps); 1 No. layer: bedded in and including cement and sand (1:3) mortar	SM	552		
	<b>Concrete Blinding</b>				
	<b>In situ concrete Class 15MPa: vibrated:</b>				
I	50 mm Thick under strip foundation	SM	113		
J	50 mm Thick under column bases	SM	20		
	<b>In- situ vibrated reinforced concrete Class 25MPa: in:</b>				
K	Column bases	CM	6		
L	Columns	CM	2		
M	Ground beams	CM	8		
N	Strip foundation	CM	23		
O	Steps	CM	2		
P	100mm thick surface bed	SM	552		
Q	Slab thickening 200x300mm thick	LM	9		
	<b>Carried to collection</b>				

Item	DESCRIPTION	Unit	QTY	Rate	Amount
	<b>Ribbed reinforcement steel bars to KS 573:2014 : Grade 500 high tensile strength including bends, hooks, tying wire and distance blocks; to S.E's detail ( Provisional)</b>				
A	Assorted reinforcement	KG	2,514		
	<b>Mesh fabric reinforcement to KS/EAS 412;2 (2019) BRC A142;200 x 200mm, weighing 2.22kg/m<sup>2</sup> (measured net - no allowance) for laps; in two layers - top &amp; bottom; including bends, tying wire and spacer blocks)</b>				
B	In floor beds	SM	552		
	<u>Modular steel frame with steel plates covering formwork and/or marine board formwork: to:</u>				
C	Vertical sides to columns	SM	40		
D	Vertical sides to column bases	SM	24		
E	Vertical sides to strip footing	SM	75		
F	Vertical sides to ground beams	SM	75		
G	Edge of slab not exceeding 150mm girth	LM	80		
H	Edge of risers not exceeding 150mm girth	LM	81		
	<b>Foundation Walling</b>				
	<b>Natural quarry stone walling with a minimum of 7.0 N/mm<sup>2</sup> bedded and jointed in cement and sand (1:4) mortar, reinforced with and including 25 x 3 mm thick hoop iron strips at every alternate course as described in;</b>				
I	200mm thick walls in foundations	SM	332		
	<b><u>Pavings</u></b>				
J	Supply and lay 600 x 600 x 50mm reinforced concrete precast paving slabs around the building including laying, spreading and compacting 100mm thick approved sand bed blinding, on and including 150mm thick compacted hardcore to Engineer's approval.	SM	48		
	<b><u>Plinth</u></b>				
	<b><u>25mm Thick cement and sand (1:3) rendering on concrete or masonry ; wood float finished; to</u></b>				
K	Plinths externally	SM	36		
	<b>Two coats black bitumastic paint on:</b>				
L	Rendered surfaces	SM	36		
	<b>Carried to collection</b>				



Item	DESCRIPTION	Unit	QTY	Rate	Amount
	<p><b>COLLECTION</b></p> <p>Total brought forward from page no: 1</p> <p>Total brought forward from page no: 2</p> <p>Total brought forward from page no: 3</p>				
	<p><b>ELEMENT NO. 1</b></p> <p><b>SUBSTRUCTURES</b></p>				
	<p>Carried to Main summary</p>				

Item	DESCRIPTION	Unit	QTY	Rate	Amount
	<p><b>PROPOSED KINDERGARTEN</b></p> <p><b>BILL NO.1-BUILDERS WORKS</b></p> <p><b>ELEMENT No 2 - R.C FRAME</b></p> <p><i>In situ concrete class 25MPa: vibrated: reinforced</i></p>				
A	Columns	CM	2		
B	Ring beam	CM	23		
C	Ramp	SM	5		
	<p><b>Ribbed reinforcement steel bars to KS 573:2014 : Grade 500 high tensile strength including bends, hooks, tying wire and distance blocks; to S.E's detail ( Provisional)</b></p>				
D	Assorted reinforcement	Kg	3,776		
	<i>Modular steel frame with steel plates covering formwork and/or marine board formwork: to</i>				
E	Sides and soffites of beams	Sm	150		
F	Sides of columns	Sm	41		
	<p><b>ELEMENT NO. 2</b>                      <b>Carried to</b></p> <p><b>R.C FRAME</b>                              <b>Main summary</b></p>				

Item	DESCRIPTION	Unit	QTY	Rate	Amount
	<p><b><u>PROPOSED KINDERGARTEN</u></b></p> <p><b>BILL NO.1-BUILDERS WORKS</b></p> <p><b>ELEMENT No 3-WALLING</b></p> <p><b><u>WALLING</u></b></p> <p><b><u>External Walling</u></b></p> <p><i><u>Machine cut quarry stone walling with a minimum of 7.0 N/mm<sup>2</sup> bedded and jointed in cement and sand (1:4) mortar, reinforced with and including 25 x 3 mm thick hoop iron strips at every alternate course as described in;</u></i></p>				
A	200mm thick walling Externally	Sm	210		
B	200mm thick Gable walling	Sm	74		
	<p><b><u>Internal Walling</u></b></p> <p><i><u>Machine cut quarry stone walling with a minimum of 7.0 N/mm<sup>2</sup> bedded and jointed in cement and sand (1:4) mortar, reinforced with and including 25 x 3 mm thick hoop iron strips at every alternate course as described in;</u></i></p>				
C	200mm thick walling Internally	Sm	81		
D	150mm thick walling Internally	Sm	20		
E	Approved hessian based damp proof course to 200mm thick walling in cement/sand mortar	Lm	187		
	<p><b><u>ELEMENT NO. 3</u></b>                      <b>Carried to</b></p> <p><b><u>WALLING</u></b>                                <b>Main summary</b></p>				

Item	DESCRIPTION	Unit	QTY	Rate	Amount
	<p><b><u>PROPOSED KINDERGARTEN</u></b></p> <p><b>BILL NO.1-BUILDERS WORKS</b></p> <p><b>ELEMENT NO 4-WINDOWS</b></p> <p><b><u>MILD STEEL WINDOWS</u></b></p> <p>Supply, fabricate and fix the following purpose made mild steel casement windows to be fabricated from approved mild steel sections (atleast 14g 2mm thick ) comprising of frame and casement incorporating permanent hooded high level ventilation panels infilled with mosquito gauze : window supplied complete with and including 12mm solid square burglar proofing bars fixed at 200mm centres both ways and metal fixing lugs including building into wall and making good, and all necessary iron mongery viz hinges, fasteners, and hasp including shop priming window with red oxide primer before delivery to site:-</p> <p>A prime cost sum of Kshs 4,500 per Sqm has been allowed for fabrication of the above specified Steel casement Windows by AHP juakali artisans as approved by the Project Manager/Architect.</p> <p>The contractor's unit rate shall include the cost of transport, storage, fixing and all associated accesories in addition to the PC Rate.</p>				
A	Window, overall size 2400 X 1500mm high to Architects Details	NO	11		
B	Ditto Size 600 x 900mm high (WC/SH)	NO	3		
C	Ditto size 525 X 1500mm high to Architects Details	NO	13		
	<b><u>Glazing</u></b>				
C	4mm Thick clear sheet glass panes over 0.1 but not exceeding 0.5 square meters; fixing with premium putty	SM	50		
D	Ditto; obscure	SM	2		
	<b><u>Painting and Decorations</u></b>				
	<b><u>On Metal work</u></b>				
	<b><u>Prepare and apply aerosol spray painting in two finishing coats of first grade Crown Solo or other equal and approved to: -</u></b>				
E	General window and grille surfaces; over 300mm girth internal	SM	102		
	<b>Carried to Collection</b>				

Item	DESCRIPTION	Unit	QTY	Rate	Amount
A	<p><b><u>Precast concrete window cill finishing fair on all exposed surfaces and hoisting and placing in position, bedding, jointing and pointing in pigmented cement and sand (1:3) mortar</u></b></p> <p>150 x 25mm thick precast concrete window sill</p> <p><b>Carried to collection</b></p> <p><b>COLLECTION</b></p> <p>Total brought forward from page no: 7</p> <p>Total brought forward from page no: 8</p>	LM	37		
	<p><b><u>ELEMENT NO. 4</u></b></p> <p><b><u>WINDOWS</u></b></p>	Carried to the	Main summary		

Item	DESCRIPTION	Unit	QTY	Rate	Amount
	<p><b><u>PROPOSED KINDERGARTEN</u></b></p> <p><b>BILL NO.1-BUILDERS WORKS</b></p> <p><b>ELEMENT NO 5-DOORS</b></p> <p><b><u>Steel Casement Doors</u></b></p> <p>Supply, fabricate and fix the following purpose made mild steel casement door comprising 40 x 25 x3mm stiles, top and bottom stiles, 4 No Intermediate rails, 1.5mm steel sheet both sideswelded in place and 5mm thick clear glazing, all primed with red oxide and spray painted with two finishing coats of first grade quality gloss oil paint on ; complete with all necessary ironmongery fasteners and necessary seremetals assembled and fixed to opening including cutting and pinning lugs to concrete or block work sorroung and bedding frame in cement and sand mortar (1:3).</p>				
A	Door size 900 x 2400mm high	NO	4		
B	Ditto Door size 1500 x 2400mm high	NO	1		
	<i><u>Frames and frame finishes in cypress Timber</u></i>				
C	25 x 25mm quadrant (PC Rate Kshs 75)	LM	38		
D	25 x 50mm architrave with two labours, plugged (PC Rate Kshs 150)	LM	38		
E	150mm x 50mm frame with three labours; chamfered edges; plugged (PC Rate Kshs 800)	LM	38		
	<p><b>Flush timber doors</b></p> <p><b>50 mm thick Semi Solid cored flush doors with plywood facing to receive painting (m.s) all to Architects details, specifications and approval</b></p> <p><b>A prime cost sum at the rate indicated below for fabrication of the above specified Timber Flush door leaves by AHP juakali artisans as approved by the Project Manager/Architect.</b></p> <p><b>The contractor's unit rate shall include the cost of transport, storage, fixing and all associated accesories in addition to the PC Rate.</b></p>				
F	Door size 900mm x 2060mm (PC Rate Kshs 4,000)	NO	4		
G	Ditto Size 800 x 2060mm high (PC Rate Kshs 3,500)	NO	4		
	<b>Carried to collection</b>				

Item	DESCRIPTION	Unit	QTY	Rate	Amount
	<u>Painting and decorating</u>				
	<u>Priming back of frame with an aluminium or equivalent and approved wood primer</u>				
A	Surfaces not exceeding 100mm girth	LM	76		
B	Surfaces over 100mm but not exceeding 200mm girth	LM	38		
	<u>Prepare Knot, prime, stop and apply one undercoat and two finishing coats first grade timber quality paint to wood surfaces as per the manufacturer's printed instructions</u>				
C	General timber surfaces	SM	26		
D	Surfaces not exceeding 200mm girth	LM	38		
E	Architraves: not exceeding 100 mm girth□	LM	38		
F	Quadrant beading : not exceeding 100 mm girth	LM	38		
	<b>Ironmongery</b>				
	<b>Supply and fix the following ironmongery to timber complete with matching screws and keys to the approval of the Architect</b>				
	<u>Supply and Fix the following ironmongery to the approval of the Architect</u>				
G	100mm pressed steel Butt Hinges	Pairs	12		
H	Stainless steel 2 Lever Door Lock with handles	NO	8		
I	Door fixing cramps	NO	8		
	<b>Carried to Collection</b>				
	<b>COLLECTION</b>				
	Total brought forward from page no: 9				
	Total brought forward from page no: 10				
	<b>ELEMENT NO. 5</b>	<b>Carried to</b>			
	<b>DOORS</b>	<b>Main summary</b>			

Item	DESCRIPTION	Unit	QTY	Rate	Amount
	<p><b>PROPOSED KINDERGARTEN</b></p> <p><b>BILL NO.1-BUILDERS WORKS</b></p> <p><b>ELEMENT NO 6 - EXTERNAL FINISHES</b></p> <p><b>EXTERNAL WALL FINISHES</b></p> <p><b>External Finish</b></p> <p><i>Cement and sand (1:3) render:wood floated: on concrete or blockwork: to</i></p>				
A	<p>15mm thick to columns/beams surfaces externally</p> <p><b>Keying</b></p>	SM	191		
B	<p>Extra over horizontal and vertical pointing in 10mm thick rod in cement and sand mix (1:3) mortar including one coat Bituminous paint</p> <p><b>External Painting</b></p> <p><i>Prepare and apply one coat Alkali Resistant primer followed by two finishing coats of silicon exterior Emulsion paint in accordance with the manufacturers written instructions and to the satisfaction of the architect to</i></p>	SM	284		
C	<p>Columns surfaces externally</p>	SM	191		
	<p><b>ELEMENT NO. 6</b> Carried to <b>EXTERNAL FINISHES</b> Main summary</p>				



Item	DESCRIPTION	Unit	QTY	Rate	Amount
	<p><b><u>PROPOSED KINDERGARTEN</u></b></p> <p><b>BILL NO.1-BUILDERS WORKS</b></p> <p><b>ELEMENT NO 7 - INTERNAL FINISHES</b></p> <p><b><u>Internal Wall Finishes</u></b></p> <p><u>Cement and sand (1:3) backings</u></p>				
A	<p>15mm thick to receive ceramic Wall tiles</p> <p><u>Ceramic wall tiles</u></p> <p><u>Allow a Prime Cost supply rate of Ksh. 1000 per SM (Rate to include cost of purchase, transport, offload, storage, fixing including all necessary adhesives and accessories</u></p>	SM	54		
B	<p>Supply and Fix approved ceramic wall tiles on prepared backings(m.s) with proprietary adhesive; jointed and pointed in matching coloured proprietary grouting; including pvc spacers and expansion joint as necessary: all to Architect's approval. - Wall Surfaces</p> <p><u>15mm (minimum) two coat cement, sand (1:3) plaster complete with wire gauze anti-crack mechanism at the intersection of masonry walling and concrete beams as described to:-</u></p>	SM	54		
C	Concrete/masonry surfaces	SM	431		
D	Ditto to door Jambs Externally and Surfaces not exceeding 200mm girth	LM	206		
	<p><b><u>Painting and Decoration</u></b></p> <p><u>Prepare, Skim and apply Emulsion or universal undercoat followed by two finishing coats of soft satin Emulsion paint in accordance with the manufacturers written instructions and to the satisfaction of the architect to</u></p>				
E	Plastered concrete/masonry surfaces internally	SM	431		
F	Ditto to window cills, door Jambs Externally and Surfaces not exceeding 200mm girth	LM	206		
	<b>Carried to Collection</b>				

Item	DESCRIPTION	Unit	QTY	Rate	Amount
	<b><u>Floor Finishes</u></b>				
	<u>Cement and sand (1:3) screeds, backings, beds etc</u>				
A	32mm bed finished to receive Floor Tiles (m.s)	SM	487		
B	32mm Thick coloured cement sand screed mix 1:3 finished with red oxide to approval	SM	5		
	<b>Steps finishes</b>				
	<u>Cement and sand (1:4 ) backings etc</u>				
C	25 x 300 mm wide treads to receive ceramic tiles (m.s)	LM	80		
D	20 x 150mm risers to receive ceramic tiles (m.s)	LM	81		
	<u>Ceramic Floor tiles</u>				
	<u>Allow a Prime Cost supply rate of Ksh. 1000 per SM (Rate to include cost of purchase, transport, offload, storage, fixing including all necessary adhesives and accessories</u>				
E	Supply and Fix Ceramic tiles, on prepared bed(m.s) with proprietary adhesive; jointed and pointed in matching coloured proprietary grouting; including pvc spacers and expansion joint as necessary: all to Architect's approval.	SM	487		
F	Ditto Non Slip Ceramic Tiles	SM	0		
G	Ditto 100mm wide Wall Skirtings	LM	259		
	<b>Steps finishes</b>				
H	Non Slip Ceramic Tiles to 300 mm wide treads	LM	80		
I	Non Slip Ceramic Tiles to 150mm risers	LM	81		
	<b>Carried to Collection</b>				

Item	DESCRIPTION	Unit	QTY	Rate	Amount
A	<p><b><u>Ceiling finishes</u></b></p> <p><u>Chipboard ceiling</u></p> <p>Supply and fix 6mm thick chipboard ceiling on timber branderling (m.s)</p> <p><u>Painting and Decoration</u></p> <p><u>Prepare, skim and apply Emulsion or universal undercoat followed by 3 coats of soft satin Emulsion paint in accordance with the manufacturers written instructions and to the satisfaction of the architect to</u></p>	SM	492		
B	<p>Chipboard Ceiling</p> <p><b>Timber branderling</b></p> <p><u>Sawn cypress timber</u></p>	SM	492		
C	<p>50x50mm branderling at 600mm c/c</p>	SM	492		
	<b>Carried to Collection</b>				

Item	DESCRIPTION	Unit	QTY	Rate	Amount
	<p><b>COLLECTION</b></p> <p>Total brought forward from page no: 12</p> <p>Total brought forward from page no: 13</p> <p>Total brought forward from page no: 14</p>				
	<p><b><u>ELEMENT NO. 7</u> Carried to</b> <b>INTERNAL FINISHES</b></p>				

Item	DESCRIPTION	Unit	QTY	Rate	Amount
	<p><b>PROPOSED KINDERGARTEN</b></p> <p><b>BILL NO.1-BUILDERS WORKS</b></p> <p><b>ELEMENT NO 8 - ROOFING</b></p> <p><b><u>ROOF STRUCTURE (GABLE ROOF)</u></b></p> <p><b><u>Note: All structural timber to be celcured [factory impregnated]</u></b></p> <p><b><u>Note:All timber members are jointed using galvanised nails and timber plates.</u></b></p> <p><u>First grade sawn cypress: Approved structural grade: with and including all jointing and connections as necessary: in roof trusses</u></p> <p><u>(All timber work is provisional)</u></p>				
A	150 x 50 mm wall plate: fixed to masonry blocks: including hoop iron at 900mm centres	LM	104		
B	150 x 50 mm ridge board	LM	111		
C	100 x 50 rafters	LM	1,316		
D	100 x 50 mm Purlins	LM	592		
E	200 x 25 mm Fascia and barge boards	LM	104		
	<b><u>ROOF COVERING</u></b>				
F	Gauge 30 prepainted Galvanised Corrugated Iron roofing sheets as MRM or other equal and approved:200mm head laps:2 corrugations side laps nailed to purlins with galvanised naills c/w matching rubber washers	SM	658		
G	Ditto: ridge caps : 200mm overlap	LM	56		
	<b><u>RAIN WATER GOODS</u></b>				
H	PVC Gutters size 200mm dia fixed to fascia boards (m/s) with and including approved steel brackets at 1000mm centres	LM	104		
I	Ditto: 100mm diameter offset	NO	14		
J	Ditto: 100mm diameter downpipe fixed to the wall using brackets	NO	46		
K	Ditto: 100mm diameter shoe	NO	14		
	<b>ELEMENT NO. 8 ROOFING Carried to the Main summary</b>				

Item	DESCRIPTION	Unit	QTY	Rate	Amount
	<b><u>PROPOSED KINDERGARTEN</u></b>				
	<b>BILL NO.1-BUILDERS WORKS</b>				
	<b>MAIN SUMMARY</b>		<b><u>PAGE</u></b>		
<b>1</b>	<b>Substructures</b>		<b>C/4</b>		
<b>2</b>	<b>Reinforced Concrete Frame</b>		<b>C/5</b>		
<b>3</b>	<b>Walling</b>		<b>C/6</b>		
<b>4</b>	<b>Windows</b>		<b>C/8</b>		
<b>5</b>	<b>Doors</b>		<b>C/10</b>		
<b>6</b>	<b>External Finishes</b>		<b>C/11</b>		
<b>7</b>	<b>Internal Finishes</b>		<b>C/15</b>		
<b>8</b>	<b>Roofing</b>		<b>C/16</b>		
	<b><u>TOTAL FOR KINDERGARTEN CARRIED TO GRAND SUMMARY</u></b>				

**SCHOOL**

Item	DESCRIPTION	Unit	QTY	Rate	Amount
	<p><b><u>PROPOSED PRIMARY SCHOOL</u></b></p> <p><b>BILL NO.1-BUILDERS WORKS</b></p> <p><b>ELEMENT NO 1 - SUBSTRUCTURES (ALL PROVISIONAL)</b></p> <p><b>Notes.</b>  <b>This element includes all structural works up to and including ground floor slab</b>  <b>Tenderer to allow for working space in his rates.</b></p> <p><b>Excavations including trimming sides and bottoms of excavations; maintaining and supporting sides; and keeping free from water, mud and fallen material; with and including destruction of termites nests within site of works,take out and destroy queens, imp</b></p> <p><i>Site Clearance</i></p>				
A	Clear site of all grass, hedges, shrubs, bushes grub up roots, load and remove from site and dispose at designated local authority areas.	SM	1,598		
B	Excavate average 300mm deep to remove top vegetable soil, load, remove from site and dump in designated local authority dump site.	Cm	479		
D	Excavate for Strip foundations depth not exceeding 1.50 metres starting from Reduced ground levels.	Cm	307		
E	Excavate for column bases depth not exceeding 1.5m starting from reduced Levels	Cm	616		
F	Extra over excavation for excavating in all classes of rock	Cm	92		
G	Allow for keeping the whole of the excavation free from all spring and running water by pumping or any other such means as may be necessary	Item	1		
H	Allow for maintaining and upholding the sides of excavations and keeping excavations clear of all fallen materials, rubbish etc	Item	1		
	<b>Carried to collection</b>				



Item	DESCRIPTION	Unit	QTY	Rate	Amount
	<u>Disposal</u>				
A	Return, fill and ram selected excavated material around foundations.	CM	462		
B	Load,wheel and cart away surplus excavated material away from site	CM	553		
	<b>Backfill</b>				
C	Make up levels using approved imported materials: compacted in layers not exceeding 300mm thick with a 15ton roller: to the satisfaction of the Structural Engineer.	CM	1,119		
	<b>Hardcore as described</b>				
D	300mm thick hardcore bed: hand packed : compacted in layers not exceeding 150mm thick: to the satisfaction of the Structural Engineer: including 50mm Thick murrum or "equal and approved" blinding to surfaces of hardcore	SM	1,598		
	<b>Anti - termite to treatment</b>				
E	Chemical anti-termite treatment, executed complete by an approved specialist under a ten-year guarantee,to surfaces of hardcore and below raft foundations	SM	1,598		
	<b>Damp-proof membrane</b>				
F	1000 gauge polythene or other equal and approved damp-proof membrane, laid over blinded hardcore (measured separately) with 300mm side and end laps (measured nett-allow for laps)	SM	1,598		
	<b>Insitu concrete Class 15MPa: vibrated:</b>				
G	Plain concrete class 15 in 50 mm Thick under column bases	SM	411		
H	Plain concrete class 15 in 50 mm Thick under strip foundation	SM	205		
I	50 mm Thick Murrum Blinding to surfaces of hadcore	SM	1,598		
	<b>In- situ vibrated reinforced concrete Class 25MPa: in:</b>				
J	Column bases	CM	196		
K	Columns	CM	14		
L	Strip foundation	CM	82		
M	100mm thick surface bed	SM	1,598		
	<b>Carried to collection</b>				

Item	DESCRIPTION	Unit	QTY	Rate	Amount
A	<b>Ribbed reinforcement steel bars to KS 573:2014 : Grade 500 high tensile strength including bends, hooks, tying wire and distance blocks; to S.E's detail ( Provisional)</b> Assorted reinforcement	Kg	6,577		
B	<b>Mesh fabric reinforcement to KS/EAS 412;2 (2019) BRC A142;200 x 200mm, weighing 2.22kg/m<sup>2</sup> (measured net - no allowance) for laps; in two layers - top &amp; bottom; including bends, tying wire and spacer blocks)</b> Mesh reference A142 weighing 2.22 kilogrammes per square metre in floor beds.	SM	1,598		
C	<u>Modular steel frame with steel plates covering formwork and/or marine board formwork: to:</u> Vertical sides to columns	SM	210		
D	Edge of slab, over 150mm but not exceeding 225mm girth	LM	330		
E	<b>SUBWALL</b> <b>Natural quarry stone walling with a minimum of 7.0 N/mm<sup>2</sup> bedded and jointed in cement and sand (1:4) mortar, reinforced with and including 25 x 3 mm thick hoop iron strips at every alternate course as described in;</b> 200mm thick walls in foundations	SM	1,000		
F	<b>Pavings</b> Supply and lay 600 x 600 x 50mm reinforced concrete precast paving slabs around the building including laying, spreading and compacting 100mm thick approved sand bed blinding, on and including 150mm thick compacted hardcore to Engineer's approval.	SM	198		
G	<b>Plinth</b> 1:4 cement/sand render to plinth	SM	198		
H	Black bituminous paint to rendered plinth	SM	198		
	<b>Carried to collection</b>				

Item	DESCRIPTION	Unit	QTY	Rate	Amount
	<b>COLLECTION</b>				
	Total brought forward from page no:		LPS/1		
	Total brought forward from page no:		LPS/2		
	Total brought forward from page no:		LPS/3		
	<b><u>ELEMENT NO. 1</u></b>				
	<b><u>SUBSTRUCTURES</u></b>				
	Carried to Main summary				

Item	DESCRIPTION	Unit	QTY	Rate	Amount
<b><u>PROPOSED PRIMARY SCHOOL</u></b>					
<b>BILL NO.1-BUILDERS WORKS</b>					
<b>ELEMENT No 2 - R.C FRAME</b>					
<i>In- situ vibrated reinforced concrete Class 25MPa: in:</i>					
A	Columns	CM	67		
B	Ring beam	CM	200		
C	Ramp	SM	392		
D	Stairs	CM	36		
F	150mm thick suspended slabs	SM	1,022		
<b>Hollow Pot slab</b>					
230x380x300mm Thick hollow pot slabs including A142 BRC Mesh laid centrally and horizontally in 70mm thick concrete topping; 150mm thick reinforced concrete ribs at spacing of 380mm c/c all to Structural engineers details					
G	Ditto to Roof Slab	SM	3,732		
		SM	1,578		
<b>Ribbed reinforcement steel bars to KS 573:2014 : Grade 500 high tensile strength including bends, hooks, tying wire and distance blocks; to S.E's detail ( Provisional)</b>					
E	Assorted reinforcement to Structural Engineer's specifications	Kg	63,450		
<i>Modular steel frame with steel plates covering formwork and/or marine board formwork: to:</i>					
F	Sides and soffits of beams	Sm	2,407		
G	Sides of columns	Sm	1,008		
O	Soffits of hollow pots / concrete blocks slabs	Sm	5,370		
O	Soffits of insitu cast suspended slabs	Sm	1,022		
O	Sloping Soffits of ramp	Sm	392		
Q	To sloping soffits of staircases	SM	96		
R	Soffits of landings	SM	40		
S	Riser of steps over 150 mm but not exceeding 225 mm girth	LM	260		
T	Staircase string 300mm extreme girth and cut to profile of steps	LM	120		
U	Edges of landing over 150 but not exceeding 225mm high	Lm	26		
P	Edges of suspended slab over 150mm but not exceeding 225mm girth	Lm	1,320		
<b><u>ELEMENT NO. 2</u></b>		<b>Carried to</b>			
<b><u>R.C FRAME</u></b>		<b>Main summary</b>			

Item	DESCRIPTION	Unit	QTY	Rate	Amount
<b>PROPOSED PRIMARY SCHOOL</b> <b>BILL NO.1-BUILDERS WORKS</b> <b>ELEMENT No 3-WALLING</b> <b>WALLING</b> <i>Machine cut quarry stone walling with a minimum of 7.0 N/mm<sup>2</sup> average compressive strength; bedded and jointed in cement and sand (1:4) mortar, reinforced with and including 25 x 3 mm thick hoop iron strips at every alternate course as described in;</i>					
A	200mm thick walling Externally	Sm	2,401		
B	200mm thick Gable walling	Sm	-		
C	200mm thick walling Internally	Sm	3,226		
D	100mm thick walling Internally	Sm	458		
E	200mm Thick Parapet walling	Sm	330		
F	Approved hessian based damp proof course to 200mm thick walling in cement/sand mortar	Lm	547		
	<b>ELEMENT NO. 3</b> Carried to <b>WALLING</b> Main summary				

Item	DESCRIPTION	Unit	QTY	Rate	Amount
	<p align="center"><b><u>PROPOSED PRIMARY SCHOOL</u></b></p> <p align="center"><b>BILL NO.1-BUILDERS WORKS</b></p> <p><b>ELEMENT NO 4-WINDOWS</b></p> <p><b><u>METAL WORK</u></b></p> <p><b><u>PURPOSE - MADE UNITS</u></b></p> <p><b><u>Supply, assemble and fix the following purpose-made mild steel casement windows; standard metal section from approved manufacturer complete with frames, transomes, mullions and with and including permanent ventilators comprising "T" bar, gauze and 16 gauge sheet metal hood 50mm high x 50mm projection to full width of window, coupling mullions, approved ironmongery and one coat manufacturer's primer; all welding ground to smooth finish.</u></b></p> <p><b>Steel; for glazing with putty, lugs to two jambs, cutting and pinning to concrete or blockwork, fixing to head and sill with screws; plugging</b></p> <p><b>A prime cost sum of Kshs 4,500 per Sqm has been allowed for fabrication of the above specified Steel casement Windows by AHP juakali artisans as approved by the Project Manager/Architect.</b></p> <p><b>The contractor's unit rate shall include the cost of transport, storage, fixing and all associated accessories in addition to the PC Rate.</b></p>				
A	Window, overall size 2400 X 1500mm high to Architects Details	NO	117		
	Window, overall size 1500 X 1500mm high to Architects Details	NO	24		
B	Ditto Size 600 x 900mm high (WC/SH)	NO	100		
	<b><u>Glazing</u></b>				
C	4mm Thick clear sheet glass panes over 0.1 but not exceeding 0.5 square meters; fixing with putty	SM	475		
D	Ditto; obscure	SM	54		
	<b><u>Painting and Decorations</u></b>				
	<b><u>On Metal work</u></b>				
	<b><u>Prepare and apply aerosol spray painting in two finishing coats of first grade Crown Solo or other equal and approved to: -</u></b>				
E	General window and grille surfaces; over 300mm girth internal	SM	529		
	<b>Carried to Collection</b>				

Item	DESCRIPTION	Unit	QTY	Rate	Amount
A	<p><b>Precast concrete window cill finishing fair on all exposed surfaces and hoisting and placing in position, bedding, jointing and pointing in pigmented cement and sand (1:3) mortar</b></p> <p>150 x 25mm thick Precast concrete window sill</p> <p style="text-align: center;"><b>Carried to collection</b></p> <p style="text-align: center;"><b>COLLECTION</b></p> <p>Total brought forward from page no:</p> <p>Total brought forward from page no:</p>	LM	473		
	<p><b><u>ELEMENT NO. 4</u></b></p> <p><b><u>WINDOWS</u></b></p>				

Item	DESCRIPTION	Unit	QTY	Rate	Amount
	<b><u>PROPOSED PRIMARY SCHOOL</u></b>				
	<b>BILL NO.1-BUILDERS WORKS</b>				
	<b>ELEMENT NO 5-DOORS</b>				
	<b><u>Steel Casement Doors</u></b>				
A	Heavy gauge steel casement doors size 900 x 2400mm high comprising 40 x 25 x3mm stiles, top and bottom stiles, 4 No Intermediate rails, 1.5mm steel sheet both sideswelded in place and 5mm thick clear glazing, all primed with red oxide and spray painted 2 coats eggshell gloss paint; complete with hinges, stays, fasteners and necessary seremetals assembled and fixed to opening including cutting and pinning lugs to concrete or block work surround and bedding frame in cement and sand mortar (1:3). (D.01)	NO	3		
B	Ditto Size 1500 x 2400mm high Doubleleaf door	NO	2		
	<b><u>Frames and frame finishes in cypress Timber</u></b>				
C	25 x 25mm quadrant (PC Rate Kshs 75)	LM	165		
D	25 x 50mm architrave with two labours, plugged (PC Rate Kshs 150)	LM	165		
E	150mm x 50mm frame with three labours; chamfered edges; plugged (PC Rate Kshs 800)	LM	165		
	<b>Flush timber doors</b>				
	<b>A prime cost sum at the rate indicated below has been allowed for fabrication of the above specified Hardwood panelled door leaves by AHP juakali artisans as approved by the Project Manager/Architect.</b>				
	<b>The contractor's unit rate shall include the cost of transport, storage, fixing and all associated accesories in addition to the PC Rate.</b>				
F	Supply and fix 1500mm x 2060mm x 50mm thick semi solid cored flush double door Ply wood finished for painting (m/s) both sides; all to Architects Details, specifications and approval (D.03)	NO	30		
G	Ditto Size 800 x 2060mm high (PC Rate Kshs 3,500)	NO	85		
G	Ditto Size 900 x 2060mm high (PC Rate Kshs 4,000)	NO	39		
	<b>Carried to collection</b>				



Item	DESCRIPTION	Unit	QTY	Rate	Amount
	<i>Painting and decorating</i>				
	<i>Prepare and apply one coat aluminium wood primer to:-</i>				
A	Surfaces not exceeding 100mm girth	LM	165		
B	Surfaces over 100mm but not exceeding 200mm girth	LM	165		
	<i>Prepare Knot, prime, stop and apply one undercoat and two finishing coats first grade timber quality paint to wood surfaces as per the manufacturer's printed instructions</i>				
C	General timber surfaces	SM	475		
D	Surfaces not exceeding 200mm girth	LM	495		
	<b>Ironmongery</b>				
	<i>Supply and Fix the following ironmongery to the approval of the Architect</i>				
E	100mm pressed steel Butt Hinges	Pairs	173		
F	2 Lever Door Lock with handles as per Union	NO	115		
G	Door fixing cramps	NO	690		
	<b>Carried to Collection</b>				
	<b>COLLECTION</b>				
	Total brought forward from page no:		LPS/9		
	Total brought forward from page no:		LPS/10		
	<b>ELEMENT NO. 5</b> Carried to				
	<b>DOORS</b> Main summary				

Item	DESCRIPTION	Unit	QTY	Rate	Amount
	<b><u>PROPOSED PRIMARY SCHOOL</u></b> <b>BILL NO.1-BUILDERS WORKS</b> <b>ELEMENT NO 6 - EXTERNAL FINISHES</b> <b>EXTERNAL WALL FINISHES</b> <b>External Finish</b> <i>Cement and sand (1:4) backings etc</i>				
A	15mm thick to beams, Columns, Slab Moulds and walling externally	SM	144		
	<b>Keying</b> Extra over horizontal and vertical pointing in 10mm thick rod in cement and sand mix (1:3) mortar including one coat Bituminous paint				
B		SM	2,587		
	<b>External Painting</b> <i>Prepare and apply one coat Alkali Resistant primer followed by two finishing coats of silicon exterior Emulsion paint in accordance with the manufacturers written instructions and to the satisfaction of the architect to</i>				
C	Columns surfaces externally	SM	144		
	<b><u>ELEMENT NO. 6</u></b> <b>Carried to</b> <b>EXTERNAL FINISHES</b> <b>Main summary</b>				

Item	DESCRIPTION	Unit	QTY	Rate	Amount
<b>PROPOSED PRIMARY SCHOOL</b>					
<b>BILL NO.1-BUILDERS WORKS</b>					
<b>ELEMENT NO 7 - INTERNAL FINISHES</b>					
<b><u>Internal Wall Finishes</u></b>					
<i>Cement and sand (1:4) backings etc</i>					
A	15mm thick to receive Wall tiles tiles - Wet areas	SM	916		
<i><u>15mm (minimum) two coat cement, sand (1:3) plaster complete with wire gauze anti-crack mechanism at the intersection of masonry walling and concrete beams as described to:-</u></i>					
B	Concrete/masonry surfaces <b>Internally</b>	SM	7,937		
C	Ditto to window cills, door Jambs Externally and Surfaces not exceeding 200mm girth	LM	1,357		
<i><u>Ceramic wall tiles</u></i>					
<i><u>Allow a Prime Cost supply rate of Ksh. 1000 per SM (Rate to include cost of purchase, transport, offload, storage, fixing including all necessary adhesives and accessories</u></i>					
D	Supply and ceramic wall tiles or equal and approved; Bidder to include all materials needed for fixing to completion as selected by the Architect: on prepared backings(m.s) with proprietary adhesive; jointed and pointed in matching coloured proprietary grouting: including pvc spacers and expansion joint as necessary: all to Architect's approval. - Wall Surfaces	SM	916		
<b><u>Painting and Decoration</u></b>					
<i><u>Prepare, Skim and apply Emulsion or universal undercoat followed by two finishing coats of soft satin Emulsion paint in accordance with the manufacturers written instructions and to the satisfaction of the architect to</u></i>					
E	Plastered concrete/masonry surfaces internally	SM	7,937		
F	Ditto to window cills, door Jambs Externally and Surfaces not exceeding 200mm girth	LM	1,357		
<b>Carried to Collection</b>					

Item	DESCRIPTION	Unit	QTY	Rate	Amount
	<b><u>Floor Finishes</u></b>				
	<u>Cement and sand (1:3) screeds, backings, beds etc</u>				
A	32mm bed finished to receive terazzo (m.s)	SM	5,810		
	Ditto for Ramp	SM	392		
B	Ditto to receive ceramic tiles finish	SM	542		
	<b><u>Staircase finishes</u></b>				
	<u>Cement and sand (1:4 ) backings etc</u>				
C	32mm bed finished to receive ceramic tiles to surfaces of Landings (m.s)	SM	40		
B	300 mm wide treads to receive ceramic tiles (m.s)	LM	260		
C	150mm risers to receive ceramic tiles (m.s)	LM	260		
	<b><u>Ceramic Floor tiles to Wet Areas</u></b>				
	<u>Allow a Prime Cost supply rate of Ksh. 1000 per SM (Rate to include cost of purchase, transport, offload, storage, fixing including all necessary adhesives and accessories</u>				
D	Supply and Fix Ceramic tiles ; Bidder to include all materials needed for fixing to completion as selected by the Architect: on prepared bed(m.s) with proprietary adhesive; jointed and pointed in matching coloured proprietary grouting; including pvc spacers and expansion joint as necessary: all to Architect's approval. - Floor Surfaces	SM	542		
	<b><u>Terazzo Finishes</u></b>				
	Prepare 40mm thick terazzo floor finish including polishing	SM	5,810		
	Ditto for ramp	SM	392		
	Ditto 25mm thick terazzo skirting 100mm high	LM	2,076		
	<b><u>Staircase finishes</u></b>				
C	32mm bed finished to receive terazzo to surfaces of Landings (m.s)	SM	40		
H	Terazzo to 300 mm wide treads	LM	260		
J	Terazzo to 150mm risers	LM	260		
	<b>Carried to Collection</b>				

Item	DESCRIPTION	Unit	QTY	Rate	Amount
	<b><u>Ceiling finishes</u></b>				
	<u>15mm (minimum) two coat cement, sand (1:3) plaster complete with wire gauze anti-crack mechanism at the intersection of masonry walling and concrete beams as described to:-</u>				
A	Soffites of Concrete surfaces	SM	6,784		
	<u>Painting and Decoration</u>				
	<u>Prepare, Skim and apply Emulsion or universal undercoat followed by two finishing coats of soft satin Emulsion paint in accordance with the manufacturers written instructions and to the satisfaction of the architect to</u>				
B	Plastered ceilings	SM	6,784		
	<b><u>Staircase soffit finishes</u></b>				
	<u>15mm (minimum) two coat cement, sand (1:3) plaster complete with wire gauze anti-crack mechanism at the intersection of masonry walling and concrete beams as described to:-</u>				
C	Soffits of staircase landing	SM	40		
D	Ditto to sloping soffites exceeding 15° from horizontal	SM	96		
	Ditto to ramp	SM	392		
E	Staircase string 300mm extreme girth and cut to profile of steps	LM	120		
	Ditto to ramp	LM	120		
	<u>Paint works</u>				
	<u>Prepare, Skim and apply Emulsion or universal undercoat followed by two finishing coats of soft satin Emulsion paint in accordance with the manufacturers written instructions and to the satisfaction of the architect to</u>				
F	Soffits of staircase landing	SM	40		
G	Ditto to sloping soffites exceeding 15° from horizontal	SM	96		
	Ditto to ramp	SM	392		
H	Staircase string 300mm extreme girth and cut to profile of steps	LM	120		
	Ditto to ramp	LM	120		
	<b>Carried to Collection</b>				

Item	DESCRIPTION	Unit	QTY	Rate	Amount
	<b>Collection</b>				
	Total brought forward from page no:		LPS/12		
	Total brought forward from page no:		LPS/13		
	Total brought forward from page no:		LPS/14		
	<b>ELEMENT NO. 7 Carried to INTERNAL FINISHES</b>				

Item	DESCRIPTION	Unit	QTY	Rate	Amount
	<p><b>PROPOSED PRIMARY SCHOOL</b></p> <p><b>BILL NO. 1-BUILDERS WORKS</b></p> <p><b>ROOF FLOOR FINISHES</b></p> <p><u>Lightweight water proofed screeds</u></p> <p>D 50mm average waterproofed lightweight screed laid to falls and crossfalls to roof slabs -upper roof including gutter bases</p> <p><u>Prepare and apply to vertical/horizontal surfaces 4mm thick APP/EPDM water proofing or other equal and approved membrane with surface finish weighing 4kg/sm; laid on primer with torch-on process ;by an approved specialist all in accordance with the manufacturers instructions including provision of a written ten (10) year anti leak guarantee. _</u></p> <p>E APP membrane applied to roof slabs - Roof Area</p> <p>F Ditto to skirting 200mm high</p> <p>G Dress membrane around 100mm rainwater outlet</p> <p><u>The Following Flat roof concrete tiles fixed with approved adhesive, laid and jointed with waterproofing bituminous compound</u></p> <p>E 20mm thick interlocking Concrete tiles of size 225 x 225mm</p>	SM	1,578		
	<b>ELEMENT NO. 8 ROOF FINISHES Carried to the Main summary</b>				

Item	DESCRIPTION	Unit	QTY	Rate	Amount
<b><u>PROPOSED PRIMARY SCHOOL</u></b>					
<b>BILL NO.1-BUILDERS WORKS</b>					
<b>MAIN SUMMARY</b>					
1	<b>Substructures</b>		<b>LPS/4</b>		
2	<b>Reinforced Concrete Frame</b>		<b>LPS/5</b>		
3	<b>Walling</b>		<b>LPS/6</b>		
4	<b>Windows</b>		<b>LPS/8</b>		
5	<b>Doors</b>		<b>LPS/10</b>		
6	<b>External Finishes</b>		<b>LPS/11</b>		
7	<b>Internal Finishes</b>		<b>LPS/15</b>		
8	<b>Roofing Finishes</b>		<b>LPS/16</b>		
<b><u>TOTAL FOR SCHOOL CARRIED TO GRAND SUMMARY</u></b>					



**MARKET**

ITEM	DESCRIPTION	UNIT	QTY	RATE	AMOUNT
	<p style="text-align: center;"><b><u>PROPOSED MARKET</u></b></p> <p style="text-align: center;"><b>BILL NO.1-BUILDERS WORKS</b></p> <p><b><u>MARKET</u></b>  Allow a provisional sum of Kenya Shillings 28,000,000  for the construction of a Market House on two levels;  Approx Area 933Sqm</p>	SUM	1	28,000,000	28,000,000
	<p style="text-align: center;"><b>TOTAL FOR PROVISIONAL SUM AND PRIME COST SUM CARRIED TO GRAND SUMMARY</b></p>				28,000,000

**SOCIAL HALL**

ITEM	DESCRIPTION	UNIT	QTY	RATE	AMOUNT
	<p><b><u>PROPOSED SOCIAL HALL</u></b></p> <p><b>BILL NO.7 BUILDERS WORKS</b></p> <p><b>ELEMENT NO 1 - SUBSTRUCTURES (ALL PROVISIONAL)</b></p> <p><b>Excavations including trimming sides and bottoms of excavations; maintaining and supporting sides; and keeping free from water, mud and fallen material; with and including destruction of termites nests within site of works,take out and destroy queens, imp</b></p> <p><i>Site Clearance</i></p>				
A	Clear site of all grass, hedges, shrubs, bushes grub up roots, load and remove from site and dispose at designated local authority areas.	SM	328		
B	Excavate average 300mm deep to remove top vegetable soil, load, remove from site and dump in designated local authority dump site.	CM	98		
C	Excavate for Strip foundations depth not exceeding 1.50 metres starting from Stripped level	SM	124		
D	Excavate for column bases depth not exceeding 1.5m starting from reduced Levels	CM	30		
E	Extra over all type of excavation for excavating in soft rock	CM	15		
	<p><b>Disposal of water</b></p>				
F	Allow for keeping the whole of the excavation free from all spring and running water by pumping or any other such means as may be necessary	Item	1		
	<p><b>Planking and strutting</b></p>				
G	Allow for maintaining and upholding the sides of excavations and keeping excavations clear of all fallen materials, rubbish etc	Item	1		
	<b>Carried to collection</b>				

ITEM	DESCRIPTION	UNIT	QTY	RATE	AMOUNT
	<b><u>Disposal of excavated material</u></b>				
A	Return, fill and ram selected excavated material around foundations.	CM	80		
B	Load, wheel and cart away surplus excavated material away from site	CM	74		
	<b>Fillings</b>				
C	Make up levels using approved imported materials: compacted in layers not exceeding 300mm thick with a 15ton roller: to the satisfaction of the Structural Engineer.	CM	230		
D	300mm thick hardcore bed: hand packed : compacted in layers not exceeding 150mm thick: to the satisfaction of the Structural Engineer: including 50mm Thick murrum or "equal and approved" blinding to surfaces of hardcore	SM	328		
E	50 mm Thick Murrum Blinding to surfaces of hadcore	SM	328		
	<b>Anti - termite to treatment</b>				
F	Approved anti-termite treatment, with ten-year guarantee, sprayed to surfaces of hardcore strictly in accordance with manufacturer's instructions.	SM	328		
	<b>Damp-proof membrane</b>				
G	1000 gauge polythene or other equal and approved damp-proof membrane, laid over blinded hardcore (measured separately) with 300mm side and end laps (measured nett-allow for laps); 1 No. layer: bedded in and including cement and sand (1:3) mortar	SM	328		
	<b>Concrete Blinding</b>				
	<b>In situ concrete Class 15MPa: vibrated:</b>				
H	50 mm Thick under column bases	SM	30		
J	Ditto strip foundation	SM	83		
	<b>In- situ vibrated reinforced concrete Class 25MPa: in:</b>				
K	Column bases	CM	6		
L	Columns	CM	2		
M	Strip foundation	CM	17		
N	100mm thick surface bed	SM	328		
	<b>Carried to collection</b>				

ITEM	DESCRIPTION	UNIT	QTY	RATE	AMOUNT
	<b>Ribbed reinforcement steel bars to KS 573:2014 : Grade 500 high tensile strength including bends, hooks, tying wire and distance blocks; to S.E's detail ( Provisional)</b>				
A	Assorted reinforcement	Kg	2,046		
	<b>Mesh fabric reinforcement to KS/EAS 412;2 (2019) BRC A142;200 x 200mm, weighing 2.22kg/m<sup>2</sup> (measured net - no allowance) for laps; in two layers - top &amp; bottom; including bends, tying wire and spacer blocks)</b>				
B	Mesh reference A142 weighing 2.22 kilogrammes per square metre in floor beds.	SM	328		
	<u>Modular steel frame with steel plates covering formwork and/or marine board formwork: to:</u>				
C	Sides of column bases, Vertical sides to columns,bases and sides of str	SM	115		
D	Edge of slab, over 150mm but not exceeding 225mm girth	LM	93		
	<b>Foundation Walling</b>				
	<b>Natural quarry stone walling with a minimum of 7.0 N/mm<sup>2</sup> bedded and jointed in cement and sand (1:4) mortar, reinforced with and including 25 x 3 mm thick hoop iron strips at every alternate course as described in;</b>				
E	200mm thick walls in foundations	SM	166		
	<b><u>Pavings</u></b>				
F	Supply and lay 600 x 600 x 50mm reinforced concrete precast paving slabs around the building including laying, spreading and compacting 100mm thick approved sand bed blinding, on and including 150mm thick compacted hardcore to Engineer's approval.	SM	56		
	<b><u>Plinth</u></b>				
	<b><u>25mm Thick cement and sand (1:4) rendering on concrete or masonry ; wood float finished; to</u></b>				
G	Plinths externally	SM	56		
	<b>Two coats black bitumastic paint on:</b>				
H	Rendered surfaces	SM	56		
	<b>Carried to collection</b>				



ITEM	DESCRIPTION	UNIT	QTY	RATE	AMOUNT
	<b>PROPOSED SOCIAL HALL</b>				
	<b>BILL NO.1-BUILDERS WORKS</b>				
	<b>ELEMENT No 2 - R.C FRAME</b>				
	<i>In- situ vibrated reinforced concrete Class 25MPa: in:</i>				
A	Columns	CM	5		
B	Ring beam	CM	7		
C	Ramp	SM	4		
D	Raised stage	CM	17		
E	Steps	CM	2		
	<b>Ribbed reinforcement steel bars to KS 573:2014 : Grade 500 high tensile strength including bends, hooks, tying wire and distance blocks; to S.E's detail ( Provisional)</b>				
F	Assorted reinforcement bars	Kg	9,650		
	<i>Modular steel frame with steel plates covering formwork and/or marine board formwork: to:</i>				
G	Sides and soffites of beams	Sm	110		
H	To vertical sides of columns	SM	58		
J	Edges of steps not exceeding 150mm girth	Lm	36		
	<b><u>ELEMENT NO. 2</u> Carried to</b>				
	<b><u>R.C FRAME</u> Main summary</b>				



ITEM	DESCRIPTION	UNIT	QTY	RATE	AMOUNT
	<b>PROPOSED SOCIAL HALL</b> <b>BILL NO.1-BUILDERS WORKS</b> <b>ELEMENT No 3-WALLING</b> <b>WALLING</b> <b>External Walling</b> <i>Machine cut quarry stone walling with a minimum of 7.0 N/mm<sup>2</sup> average compressive strength; bedded and jointed in cement and sand (1:4) mortar, reinforced with and including 25 x 3 mm thick hoop iron strips at every alternate course as described in;</i>				
A	200mm thick walling Externally	Sm	237		
B	200mm thick parapet walling	Sm	84		
	<b>Internal Walling</b> <i>Machine cut quarry stone walling with a minimum of 7.0 N/mm<sup>2</sup> average compressive strength; bedded and jointed in cement and sand (1:4) mortar, reinforced with and including 25 x 3 mm thick hoop iron strips at every alternate course as described in;</i>				
C	200mm thick walling	Sm	99		
D	150mm thick walling	Sm	15		
E	Approved hessian based damp proof course to 200mm thick walling in cement/sand mortar	Lm	138		
	<b>ELEMENT NO. 3</b> <b>Carried to</b> <b>WALLING</b> <b>Main summary</b>				

ITEM	DESCRIPTION	UNIT	QTY	RATE	AMOUNT
	<p align="center"><b>PROPOSED SOCIAL HALL</b></p> <p align="center"><b>BILL NO.1-BUILDERS WORKS</b></p> <p><b>ELEMENT NO 4-WINDOWS</b></p> <p><b><u>METAL WORK</u></b></p> <p><b><u>PURPOSE - MADE UNITS</u></b></p> <p>Supply, fabricate and fix the following purpose made small pane mild steel casement windows to be fabricated from approved mild steel sections (atleast 14g 2mm thick ) comprising of frame and casement incorporating permanent hooded high level ventilation panels infilled with mosquito gauze : window supplied complete with and including 12mm solid square burglar proofing bars fixed at 200mm centres both ways and metal fixing lugs including building into wall and making good, and all necessary iron mongery viz hinges, fasteners, and hasp including shop priming window with red oxide primer before delivery to site:-</p> <p>A prime cost sum of Kshs 4,500 per Sqm has been allowed for fabrication of the above specified Steel casement Windows by AHP juakali artisans as approved by the Project Manager/Architect.</p> <p>The contractor's unit rate shall include the cost of transport, storage, fixing and all associated accesories in addition to the PC Rate.</p>				
A	Window, overall size 2400 X 1500mm high to Architects Details (Main hall & kitchen)	NO	13		
B	Ditto Size 1200 x 1500mm high (changing rooms & washrooms)	NO	6		
	<b><u>Glazing</u></b>				
D	4mm Thick clear sheet glass panes over 0.1 but not exceeding 0.5 square meters; fixing with putty	SM	46		
E	Ditto; obscure	SM	11		
	<b><u>Painting and Decorations</u></b>				
	<b><u>On Metal work</u></b>				
	<b><u>Prepare and apply aerosol spray painting in two finishing coats of first grade approved paint as described in</u></b>				
F	General window and grille surfaces	SM	114		
	<b>Carried to Collection</b>				

ITEM	DESCRIPTION	UNIT	QTY	RATE	AMOUNT
	<p><b><u>Precast concrete window cill finishing fair on all exposed surfaces and hoisting and placing in position, bedding, jointing and pointing in pigmented cement and sand (1:3) mortar</u></b></p>				
A	150 x 25mm thick Precast concrete window sill	LM	27		
	<p><b><u>Curtain rods:</u></b></p>				
B	1.5mm thick, 20mm thick diameter twin powdercoated mild steel rod complete accessories to approval	LM	32		
	<p><b>Carried to collection</b></p>				
	<p><b>COLLECTION</b></p>				
	Total brought forward from page no:		SH/7		
	Total brought forward from page no:		SH/8		
	<p><b><u>ELEMENT NO. 4</u></b> <b><u>WINDOWS</u></b></p>	<p><b>Carried to the</b> <b>Main summary</b></p>			

ITEM	DESCRIPTION	UNIT	QTY	RATE	AMOUNT
	<b><u>PROPOSED SOCIAL HALL</u></b> <b>BILL NO.1-BUILDERS WORKS</b>  <b>ELEMENT NO 5-DOORS</b>  <b><u>External Doors</u></b>  <b><u>Mild steel casement doors</u></b>  <b>Heavy gauge purpose made mild steel door comprising 40 x 25 x3mm stiles, top and bottom stiles, 4 No Intermediate rails, 1.5mm steel sheet both sides welded in place and 5mm thick clear glazing, all primed with red oxide and spray painted with 2 coats of first quality gloss oil paint; complete with hinges, stays, fasteners and necessary metals assembled and fixed to opening including cutting and pinning lugs to concrete or block work surround and bedding frame in cement and sand mortar (1:3).</b>				
A	Door overall size 900 x 2400mm high( Entrance to Changing rooms, washrooms & kitchen)	NO	5		
B	Ditto Size 1500 x 2400mm high Doubleleaf door (Main hall)	NO	1		
	<b><u>Internal Doors</u></b>  <b>Flush timber doors</b>  <b>50 mm thick Semi Solid cored flush doors with plywood facing to receive painting (m.s) all to Architects details, specifications and approval</b>  <b>A prime cost sum at the rate indicated below has been allowed for fabrication of the above specified Hardwood panelled door leaves by AHP juakali artisans as approved by the Project Manager/Architect.</b>  <b>The contractor's unit rate shall include the cost of transport, storage, fixing and all associated accesories in addition to the PC Rate.</b>				
C	Door size 900mm x 2060mm high ( D.03) comprising of 1 No opennable leaf size 800 x 2060mm high (PC Rate Kshs 4,000)	NO	5		
	<b><u>Frames and frame finishes in cypress Timber</u></b>				
E	25 x 25mm quadrant (PC Rate Kshs 75)	LM	30		
F	25 x 50mm architrave with two labours, plugged (PC Rate Kshs 150)	LM	30		
G	150mm x 50mm frame with three labours; chamfered edges; plugged (PC Rate Kshs 800)	LM	30		
	<b>Carried to collection</b>				

ITEM	DESCRIPTION	UNIT	QTY	RATE	AMOUNT
	<i>Painting and decorating</i>				
	<i>Prepare and apply one coat aluminium wood primer to:-</i>				
A	Surfaces not exceeding 100mm girth	LM	30		
B	Surfaces over 100mm but not exceeding 200mm girth	LM	30		
	<i>Prepare Knot, prime, stop and apply one undercoat and two finishing coats first grade timber quality paint to wood surfaces as per the manufacturer's printed instructions</i>				
C	General timber surfaces	SM	18		
D	Surfaces not exceeding 200mm girth	LM	90		
	<b>Ironmongery</b>				
	<b>Supply and fix the following ironmongery to timber complete with matching screws and keys to the approval of the Architect</b>				
E	100mm pressed steel Butt Hinges	Pairs	8		
F	2 Lever Door Lock with handles as per Union	NO	5		
G	Door fixing cramps	NO	50		
	<b>Carried to Collection</b>				
	<b>COLLECTION</b>				
	Total brought forward from page no:		SH/9		
	Total brought forward from page no:		SH/10		
	<b><u>ELEMENT NO. 5</u></b>				
	<b><u>DOORS</u></b>				
	Carried to Main summary				

ITEM	DESCRIPTION	UNIT	QTY	RATE	AMOUNT
	<b>PROPOSED SOCIAL HALL</b> <b>BILL NO.1-BUILDERS WORKS</b> <b>ELEMENT NO 6 - EXTERNAL FINISHES</b> <b>EXTERNAL WALL FINISHES</b> <b>External Render</b>  <u>Cement and sand (1:3) render:wood floated: on concrete or blockwork: to</u>				
A	15mm thick to parapet walling externally	SM	84		
B	Extra over vertical and horizonatal key pointing in10 mm rod in cement and sand mix (1:3) mortar including one coat of Bituminous paint	SM	237		
	<b>External Painting</b>  <u>Prepare and apply one coat Alkali Resistant primer followed by two coats of silicon exterior Emulsion paint in accordance with the manufacturers written instructions and to the satisfaction of the architect to</u>				
C	Concrete/masonry surfaces externally-Beam, Column and Slab Moulds	SM	27		
	<b>ELEMENT NO. 6</b> <b>Carried to</b> <b>EXTERNAL FINISHES</b> <b>Main summary</b>				

ITEM	DESCRIPTION	UNIT	QTY	RATE	AMOUNT
	<b>PROPOSED SOCIAL HALL</b>				
	<b>BILL NO.1-BUILDERS WORKS</b>				
	<b>ELEMENT NO 7 - INTERNAL FINISHES</b>				
	<b><u>Internal Wall Finishes</u></b>				
	<u>15mm thick to receive ceramic Wall tiles</u>				
A	Internal wall surfaces- Wet areas	SM	22		
	<u>Ceramic wall tiles</u>				
	<u>Allow a Prime Cost supply rate of Ksh. 1000 per SM (Rate to include cost of purchase, transport, offload, storage, fixing including all necessary adhesives and accessories</u>				
B	Supply and Fix approved ceramic wall tiles on prepared backings(m.s) with proprietary adhesive; jointed and pointed in matching coloured proprietary grouting; including pvc spacers and expansion joint as necessary: all to Architect's approval. - Wall Surfaces	SM	22		
	<u>15mm (minimum) two coat cement, sand (1:3) plaster complete with wire gauze anti-crack mechanism at the intersection of masonry walling and concrete beams as described to:-</u>				
C	Concrete/masonry surfaces <b>Internally</b>	SM	414		
D	Ditto to window cills, door Jambs Externally and Surfaces not exceeding 200mm girth	LM	125		
	<b><u>Painting and Decoration</u></b>				
	<u>Prepare, Skim and apply Emulsion or universal undercoat followed by two finishing coats of soft satin Emulsion paint in accordance with the manufacturers written instructions and to the satisfaction of the architect to</u>				
E	Plastered concrete/masonry surface	SM	414		
F	Ditto to window cills, door Jambs Externally and Surfaces not exceeding 200mm girth	LM	125		
	<b>Carried to Collection</b>				

ITEM	DESCRIPTION	UNIT	QTY	RATE	AMOUNT
	<b><u>Floor Finishes</u></b>				
	<b><u>32 mm thick Cement and sand (1:3) backing on concrete surfaces,prepared to receive ceramic floor tiles to:</u></b>				
A	Floor surfaces	SM	303		
	<b><u>Ceramic Floor tiles</u></b> Allow a Prime Cost supply rate of Ksh. 1000 per SM (Rate to include cost of purchase, transport, offload, storage, fixing including all necessary adhesives and accessories				
	Supply and Fix approved ceramic wall tiles on prepared backings(m.s) with proprietary adhesive; jointed and pointed in matching coloured proprietary grouting; including pvc spacers and expansion joint as necessary: all to Architect's approval. - Wall Surfaces				
B	Floor Surfaces	SM	252		
C	Ditto Non Slip Ceramic Tiles- Floor surfaces ( wet areas)	SM	51		
D	Ditto 100mm wide Wall Skirtings	LM	183		
	<b><u>Step finishes</u></b>				
	<b><u>32 mm thick Cement and sand (1:3) backing on concrete surfaces,prepared to receive ceramic floor tiles to:</u></b>				
E	300 mm wide treads of steps	LM	58		
F	150mm high risers of steps	LM	58		
	<u>Supply and Fix non-slip Ceramic floor tiles or equal and approved; as manufactured by Saj ceramic or equal and approved; bedded and jointed in matching coloured proprietary grout on prepared on prepared backings(m.s); : including pvc spacers and expansion joint as necessary: all to Architect's approval:to:</u>				
G	300 mm wide treads of steps	LM	58		
H	150mm high risers of steps	LM	58		
	<b>Carried to Collection</b>				



ITEM	DESCRIPTION	UNIT	QTY	RATE	AMOUNT
	<b>COLLECTION</b>				
	Total brought forward from page no:		SH/12		
	Total brought forward from page no:		SH/13		
	<b>ELEMENT NO. 7</b> Carried to				
	<b>INTERNAL FINISHES</b>				

ITEM	DESCRIPTION	UNIT	QTY	RATE	AMOUNT
<b>PROPOSED SOCIAL HALL</b>					
<b>BILL NO.1-BUILDERS WORKS</b>					
<b>ELEMENT NO 8 - ROOFING</b>					
A	Approved IT5 roofing sheets laid in accordance to pertinent drawings	SM	552		
B	Gauge 26 galvanized 450 mm Ridge cap and hip cap to match roof covering	LM	21		
C	Gauge 26 galvanized ironDitto valley gutter	LM	86		
<b>STRUCTURAL STEEL CONSTRUCTION</b>					
<b>1. Prices shall include for unloading, hoisting and fixing in position including requisite staging for erection.</b>					
<b>2. Allow for factory priming in lead oxide and touching up the priming on site later</b>					
<b>3. Prices should allow for fillet weld and welded connections</b>					
<b>The following in Steel Trusses including hoisting and fixing in position 2.8m above ground floor</b>					
D	25 x 25 x 2mm Thick SHS purlins	Kg	284		
E	50 x 50 x 3mm. Thick SHS external members	Kg	1888		
F	50 x 25 x 3mm. Thick RHS internal members	Kg	172		
G	26-gauge prepainted G.I/Aluzinc box roof gutters with 100mmx75mm cross-section	LM	101		
<b>ELEMENT NO. 8 ROOFING Carried to the Main summary</b>					

ITEM	DESCRIPTION	UNIT	QTY	RATE	AMOUNT
	<u>PROPOSED SOCIAL HALL</u>				
	MAIN SUMMARY		<u>PAGE</u>		
1	Substructures		SH/4		
2	Reinforced Concrete Frame		SH/5		
3	Walling		SH/6		
4	Windows		SH/8		
5	Doors		SH/10		
6	External Finishes		SH/11		
7	Internal Finishes		SH/14		
8	Roofing		SH/15		
	TOTAL FOR 1NO. SOCIAL HALL				
	MULTIPLY BY 2.NO HALLS	X 2			2
	<u>TOTAL FOR SOCIAL HALLS CARRIED TO GRAND SUMMARY</u>				

# **POWER HOUSE**

Item	DESCRIPTION	Unit	QTY	RATE	AMOUNT
	<b><u>PROPOSED POWER HOUSE</u></b>				
	<b>BILL NO.6-BUILDERS WORKS</b>				
	<b>ELEMENT NO 1 - SUBSTRUCTURES (ALL PROVISIONAL)</b>				
	<i>Site Clearance</i>				
A	Clear site of all grass, hedges, shrubs, bushes grub up roots, load and remove from site and dispose at designated local authority areas.	SM	24		
B	Excavate average 200mm deep to remove top vegetable soil, load, remove from site and dump in designated local authority dump site.	SM	24		
C	Excavate to reduced levels in varying depths not exceeding 1.5m deep from existing ground levels.	Cm	36		
D	Ditto exceeding 1.5m deep but not exceeding 3.0m from existing reduced levels.	Cm	12		
E	Excavate for Strip foundations depth starting from Reduced ground levels.	Cm	3		
F	Excavate for duct bank depth starting from Reduced ground levels.	Cm	4		
G	Extra over all type of excavation for excavating in soft rock	Cm	3		
H	Ditto excavation in hard rock class I	Cm	3		
	<b>Disposal of water</b>				
I	Allow for keeping the whole of the excavation free from all spring and running water by pumping or any other such means as may be necessary	Item			
	<b>Planking and strutting</b>				
J	Allow for maintaining and upholding the sides of excavations and keeping excavations clear of all fallen materials, rubbish etc	Item			
	<b>Carried to collection</b>				

Item	DESCRIPTION	Unit	QTY	RATE	AMOUNT
	<b><u>Disposal of excavated material</u></b>				
A	Return, fill and ram selected excavated material around foundations.	CM	65		
B	Load, wheel and cart away surplus excavated material to a Local Authority designated dumping site or fill soil heaps as away from site instructed by the Project Engineer.	CM	15		
	<b>Fillings</b>				
C	Make up levels using approved imported materials: compacted in layers not exceeding 300mm thick with a roller: to the satisfaction of the Structural Engineer.	CM	49		
D	300mm thick hardcore bed: hand packed : compacted in layers not exceeding 150mm thick: to the satisfaction of the Structural Engineer	SM	36		
F	50 mm Thick Murram Blinding to surfaces of hardcore	SM	36		
	<b>Anti - termite to treatment</b>				
G	Approved anti-termite treatment, with ten-year guarantee, sprayed to surfaces of hardcore strictly in accordance with manufacturer's instructions.	SM	36		
	<b>Damp-proof membrane</b>				
H	1000 gauge polythene or other equal and approved damp-proof membrane, laid over blinded hardcore (measured separately) with 300mm side and end laps (measured nett-allow for laps); 1 No. layer: bedded in and including cement and sand (1:3) mortar	SM	36		
	<b>Concrete Blinding</b>				
	<b>Insitu concrete Class 15MPa: vibrated:</b>				
I	50 mm Thick under strip foundation	SM	14		
J	50 mm Thick under duct bank	SM	5		
	<b>In- situ vibrated reinforced concrete Class 25MPa: in:</b>				
L	Columns	CM	1		
N	Strip foundation	CM	3		
O	100mm thick duct bank sides	SM	13		
P	100mm thick duct bank bottom	SM	4		
Q	150 mm thick horizontal ground floor slab	SM	20		
	<b>Carried to collection</b>				

Item	DESCRIPTION	Unit	QTY	RATE	AMOUNT
A	<b>Ribbed reinforcement steel bars to KS 573:2014 : Grade 500 high tensile strength including bends, hooks, tying wire and distance blocks; to S.E's detail ( Provisional)</b> Assorted reinforcement	KG	303		
B	<b>Mesh fabric reinforcement to K/EAS 412;2 (2019) BRC A142;200 x 200mm, weighing 2.22kg/m<sup>2</sup> (measured net - no allowance) for laps; in two layers - top &amp; bottom; including bends, tying wire and spacer blocks)</b> In floor beds	SM	20		
C	<u>Modular steel frame with steel plates covering formwork and/or marine board formwork: to:</u> Vertical sides to columns	SM	10		
E	Vertical sides to strip footing	SM	9		
F	Vertical sides to duck bank sides	SM	27		
G	Vertical sides to duck bank bottom	LM	49		
H	Edge of slab not exceeding 150mm girth	LM	48		
	<b>Foundation Walling</b>  <b>Natural quarry stone walling with a minimum of 7.0 N/mm<sup>2</sup> bedded and jointed in cement and sand (1:4) mortar, reinforced with and including 25 x 3 mm thick hoop iron strips at every alternate course as described in;</b>				
I	200mm thick walls in foundations	SM	46		
	<b><u>Pavings</u></b>				
J	Supply and lay 600 x 600 x 50mm reinforced concrete precast paving slabs around the building including laying, spreading and compacting 100mm thick approved sand bed blinding, on and including 150mm thick compacted hardcore to Engineer's approval.	SM	27		
	<b><u>Plinth</u></b>  <b><u>25mm Thick cement and sand (1:3) rendering on concrete or masonry ; wood float finished; to</u></b>				
K	Plinths externally	SM	10		
	<b>Two coats black bitumastic paint on:</b>				
L	Rendered surfaces	SM	10		
	<b>Carried to collection</b>				

Item	DESCRIPTION	Unit	QTY	RATE	AMOUNT
	<p><b>COLLECTION</b></p> <p>Total brought forward from page no: 1</p> <p>Total brought forward from page no: 2</p> <p>Total brought forward from page no: 3</p>				
	<p><u>ELEMENT NO. 1</u> Carried to</p> <p><u>SUBSTRUCTURES</u> Main summary</p>				



Item	DESCRIPTION	Unit	QTY	RATE	AMOUNT
	<b>PROPOSED POWER HOUSE</b>				
	<b>BILL NO.1-BUILDERS WORKS</b>				
	<b>ELEMENT No 2 - R.C FRAME</b>				
	<i>In situ concrete class 25MPa: vibrated: reinforced</i>				
A	Columns	CM	1		
B	Ring beam	CM	1		
C	Ramp 200 mm thick average thickness	SM	4		
D	175 mm thick roof slab	SM	31		
	<b>Ribbed reinforcement steel bars to KS 573:2014 : Grade 500 high tensile strength including bends, hooks, tying wire and distance blocks; to S.E's detail ( Provisional)</b>				
E	Assorted reinforcement	Kg	606		
	<i>Modular steel frame with steel plates covering formwork and/or marine board formwork: to</i>				
F	Sides of columns	Sm	12		
G	Sides and soffites of beams	Sm	22		
H	Sloping soffits of roof slab	Sm	31		
J	Edge of ramp exceeding 150mm but not exceeding 300 mm girth	Lm	3		
K	Edges of horizontal roof slab, exceeding 150mm but not exceeding 300 mm girth	Lm	23		
	<b>ELEMENT NO. 2</b> Carried to				
	<b>R.C FRAME</b> Main summary				

Item	DESCRIPTION	Unit	QTY	RATE	AMOUNT
	<p><b>PROPOSED POWER HOUSE</b></p> <p><b>BILL NO.1-BUILDERS WORKS</b></p> <p><b>ELEMENT No 3-WALLING</b></p> <p><b>WALLING</b></p> <p><b>External Walling</b></p> <p><i>Machine cut quarry stone walling with a minimum of 7.0 N/mm<sup>2</sup> average compressive strength ;bedded and jointed in cement and sand (1:4) mortar, reinforced with and including 25 x 3 mm thick hoop iron strips at every alternate course as described in;</i></p>				
A	200mm thick walling Externally	Sm	40		
B	200mm thick parapet walling	Sm	8		
	<p><b>Precast Concrete Breeze Ventilation Blocks</b></p> <p>305 x 305 mm wide x 150 mm thick Pre Cast Concrete loured breeze ventilation blocks bedded and jointed in cement and sand (1:4) mortar including vermin proof gauge wire</p>				
C		Sm	1		
	<p><b>Damp proof courses</b></p> <p>Approved hessian based damp proof course to 200mm thick walling in cement/sand mortar</p>				
D		Lm	17		
	<p><b>Window Cill</b></p> <p><i>Precast concrete window cill finishing fair on all exposed surfaces and hoisting and placing in position, bedding, jointing and pointing in pigmented cement and sand (1:3) mortar</i></p>				
E	150 x 25mm thick Precast concrete window sill	Lm	7		
	<p><b>ELEMENT NO. 3</b> Carried to</p> <p><b>WALLING</b> Main summary</p>				

Item	DESCRIPTION	Unit	QTY	RATE	AMOUNT
	<p><b><u>PROPOSED POWER HOUSE</u></b></p> <p><b>BILL NO.1-BUILDERS WORKS</b></p> <p><b>ELEMENT NO 4-DOORS</b></p> <p><b><u>Steel Casement Doors</u></b></p> <p>Supply, fabricate and fix the following purpose made mild steel casement door comprising 40 x 25 x3mm stiles, top and bottom stiles, 4 No Intermediate rails, 1.5mm steel sheet both sideswelded in place and 5mm thick clear glazing, all primed with red oxide and spray painted with two finishing coats of first grade quality gloss oil paint on ; complete with all necessary ironmongery fasteners and necessary seremetals assembled and fixed to opening including cutting and pinning lugs to concrete or block work sorroung and bedding frame in cement and sand mortar (1:3).</p> <p>A Door size 1000 x 2500mm high</p> <p>B Ditto Door size 2000 x 2500mm high</p>				
	<p><b><u>ELEMENT NO. 4</u></b>                      <b>Carried to</b></p> <p><b><u>DOORS</u></b>                                      <b>Main summary</b></p>				

Item	DESCRIPTION	Unit	QTY	RATE	AMOUNT
	<p><b>PROPOSED POWER HOUSE</b></p> <p><b>BILL NO.1-BUILDERS WORKS</b></p> <p><b>ELEMENT NO 5 - EXTERNAL FINISHES</b></p> <p><b>EXTERNAL WALL FINISHES</b></p> <p><b>External Finish</b></p> <p><u>Cement and sand (1:3) render:wood floated: on concrete or blockwork:</u> <u>to</u></p>				
A	15mm thick to columns/beams surfaces externally	SM	17		
	<p><b>Keying</b></p> <p>Extra over horizontal and vertical pointing in 10mm thick rod in cement and sand mix (1:3) mortar including one coat Bituminous paint</p>				
B		SM	56		
	<p><b>External Painting</b></p> <p><u>Prepare and apply one coat Alkali Resistant primer followed by two finishing coats of silicon exterior Emulsion paint in accordance with the manufacturers written instructions and to the satisfaction of the architect to</u></p>				
C	Columns surfaces externally	SM	56		
	<p><b>ELEMENT NO. 5</b></p> <p><b>EXTERNAL FINISHES</b></p>				
	<p>Carried to</p> <p>Main summary</p>				

Item	DESCRIPTION	Unit	QTY	RATE	AMOUNT
	<b>PROPOSED POWER HOUSE</b>				
	<b>BILL NO.1-BUILDERS WORKS</b>				
	<b>ELEMENT NO 6 - INTERNAL FINISHES</b>				
	<b><u>Internal Wall Finishes</u></b>				
	<u>15mm (minimum) two coat cement, sand (1:3) plaster complete with wire gauze anti-crack mechanism at the intersection of masonry walling and concrete beams as described to:-</u>				
A	Concrete/masonry surfaces	SM	42		
B	Ditto to Jambs and reveals not exceeding 200mm girth	LM	30		
	<b><u>Painting and Decoration</u></b>				
	<u>Prepare, Skim and apply Emulsion or universal undercoat followed by two finishing coats of soft satin Emulsion paint in accordance with the manufacturers written instructions and to the satisfaction of the architect to</u>				
C	Plastered concrete/masonry surfaces internally	SM	42		
D	Ditto to Jambs and reveals not exceeding 200mm girth	LM	30		
	<b><u>Floor Finishes</u></b>				
	<u>Plain in-situ concrete (1:3:6/20 mm agg.)</u>				
E	40 mm Thick polished plain concrete on existing Reinforced concrete base; level or to falls; mixed with hardener ; power floated to smooth finish to approval	SM	20		
	<u>Duct bank cover plate</u>				
F	6 mm thick chequered plate in duct bank covers including Forming 50 mm wide x 50 mm deep rebate to both sides of channel at the top; with and including 50 mm x 50 mm x 5 mm thick mild steel angle framing cast in concrete with mild steel anchor bars and grouted to both rebated sides of channel; all welding ground to a smooth finish; including priming metal surfaces with red oxide primer before delivery to site and three coats gloss oil automotive spray paint finish; all to Architect's and Structural Engineer's approval	SM	24		
G	Allow a provisional sum for foundation holes for 100 mm LG x 12.5 diamter bolts	Item			
H	Allow a provisional sum for plates, bolts, nuts, washers e.t.c	Item			
	<b><u>Ceiling finishes</u></b>				
	<u>15mm (minimum) two coat cement, sand (1:3) plaster complete with wire gauze anti-crack mechanism at the intersection of masonry walling and concrete beams as described to:-</u>				
J	Soffits of Concrete surfaces	SM	24		
	<b><u>Painting and Decoration</u></b>				
	<u>Prepare, Skim and apply Emulsion or universal undercoat followed by two finishing coats of soft satin Emulsion paint in accordance with the manufacturers written instructions and to the satisfaction of the architect to</u>				
K	Plastered ceilings	SM	24		

Item	DESCRIPTION	Unit	QTY	RATE	AMOUNT
	<b>ELEMENT NO. 6</b> Carried to <b>INTERNAL FINISHES</b>				

Item	DESCRIPTION	Unit	QTY	RATE	AMOUNT
	<p><b>PROPOSED POWER HOUSE</b></p> <p><b>BILL NO.1-BUILDERS WORKS</b></p> <p><b>ELEMENT NO 7 - ROOFING</b></p> <p><b>ROOF FINISHES</b></p> <p><b>Cement and sand (1:4) screeded beds: on concrete: complete with coloured pigmentation additives and hardener to:</b></p>				
A	<p>50mm average waterproofed lightweight screed laid to falls and crossfalls to roof slabs -upper roof including gutter bases</p> <p><u>Prepare and apply to vertical/horizontal surfaces 4mm thick APP/EPDM water proofing or other equal and approved membrane with surface finish weighing 4kg/ sm; laid on primer with torch-on process ;by an approved specialist all in accordance with the manufacturers instructions including provision of a written ten (10) year anti leak guarantee.</u></p>	SM	31		
B	4mm thick APP membrane applied to roof slabs	SM	31		
C	Ditto to skirting 200mm high	LM	20		
D	Dress membrane around 100mm rainwater outlet	No.	2		
	<u>The Following Flat roof concrete tiles fixed with approved adhesive, laid and jointed with waterproofing bituminous compound</u>				
E	20mm thick interlocking Concrete tiles of size 225 x 225mm	SM	31		
	<b>ELEMENT NO. 7 ROOFING Carried to the Main summary</b>				

Item	DESCRIPTION	Unit	QTY	RATE	AMOUNT
	<b><u>PROPOSED POWER HOUSE</u></b>				
	<b>BILL NO.1-BUILDERS WORKS</b>				
	<b>MAIN SUMMARY</b>		<b><u>PAGE</u></b>		
<b>1</b>	<b>Substructures</b>		<b>C/4</b>		
<b>2</b>	<b>Reinforced Concrete Frame</b>		<b>C/5</b>		
<b>3</b>	<b>Walling</b>		<b>C/6</b>		
<b>5</b>	<b>Doors</b>		<b>C/7</b>		
<b>6</b>	<b>External Finishes</b>		<b>C/8</b>		
<b>7</b>	<b>Internal Finishes</b>		<b>C/9</b>		
<b>8</b>	<b>Roofing</b>		<b>C/10</b>		
	<b>TOTAL FOR 1NO. POWER HOUSE</b>				
	MULTIPLY BY <b>2.NO</b> OF POWER HOUSES	<b>X 2</b>			<b>2</b>
	<b><u>TOTAL FOR POWER HOUSE TO GRAND SUMMARY</u></b>				



# **GUARD HOUSE**

Item	Description	Unit	QTY		
<b><u>PROPOSED GUARD HOUSE</u></b>					
<b>BILL NO.1-BUILDERS WORKS</b>					
<b>ELEMENT NO 1 - SUBSTRUCTURES (ALL PROVISIONAL)</b>					
<i>Site Clearance</i>					
A	Clear site of all grass, hedges, shrubs, bushes grub up roots, load and remove from site and dispose at designated local authority areas.	SM	15		
B	Excavate average 300mm deep to remove top vegetable soil, load, remove from site and dump in designated local authority dump site.	SM	15		
C	Excavate for Strip foundations depth not exceeding 1.50 metres starting from Reduced ground levels.	CM	10		
D	Ditto to column bases	CM	2		
E	Extra over all type of excavation for excavating in soft rock	CM	1		
F	Ditto excavation in hard rock class I	CM	1		
<b>Disposal of water</b>					
G	Allow for keeping the whole of the excavation free from all spring and running water by pumping or any other such means as may be necessary	Item			
<b>Planking and strutting</b>					
H	Allow for maintaining and upholding the sides of excavations and keeping excavations clear of all fallen materials, rubbish etc	Item			
<b>Carried to collection</b>					

Item	Description	Unit	QTY		
	<b><u>Disposal of excavated material</u></b>				
A	Load, wheel and cart away surplus excavated material to a Local Authority designated dumping site or fill soil heaps as away from site instructed by the Project Engineer.	CM	1.00		
B	Return, fill and ram selected excavated material around sides of foundations.	CM	12		
	<b>Fillings</b>				
C	Make up levels using approved imported materials: compacted in layers not exceeding 300mm thick with a roller: to the satisfaction of the Structural Engineer.	CM	0		
D	300mm thick hardcore bed: hand packed : compacted in layers not exceeding 150mm thick: to the satisfaction of the Structural Engineer	SM	12		
E	50 mm Stone dust/ Murrum blinding to surfaces of hardcore	SM	15		
	<b>Anti - termite to treatment</b>				
F	Approved anti-termite treatment, with ten-year guarantee, sprayed to surfaces of hardcore strictly in accordance with manufacturer's instructions.	SM	15		
	<b>Damp-proof membrane</b>				
G	1000 gauge polythene or other equal and approved damp-proof membrane, laid over blinded hardcore (measured separately) with 300mm side and end laps (measured nett-allow for laps); 1 No. layer: bedded in and including cement and sand (1:3) mortar	SM	15		
	<b>Concrete Blinding</b>				
	<b>In situ concrete Class 15MPa: vibrated:</b>				
H	50 mm thick blinding under column bases	SM	6		
I	50 mm thick blinding under strip foundations	SM	8		
	<b>In- situ vibrated reinforced concrete Class 25 MPa: in:</b>				
J	Column bases	CM	2		
K	Strip foundations	CM	2		
L	100mm thick surface bed	SM	15		
M	Steps	CM	0		
	<b>In- situ vibrated reinforced concrete Class 25 MPa: in:</b>				
N	Columns	CM	1		
	<b>Carried to collection</b>				

Item	Description	Unit	QTY		
A	<b>Ribbed reinforcement steel bars to KS 573:2014 : Grade 500 high tensile strength including bends, hooks, tying wire and distance blocks: to S.E's detail ( Provisional)</b> Assorted reinforcement	KGS	264		
B	<b>Mesh fabric reinforcement to KS/EAS 412;2 (2019) BRC A142;200 x 200mm, weighing 2.22kg/m<sup>2</sup> (measured net - no allowance) for laps; in two layers - top &amp; bottom; including bends, tying wire and spacer blocks)</b> In ground floor slab	SM	15		
C	<u>Modular steel frame with steel plates covering formwork and/or marine board formwork: to:</u> Sides of column bases	SM	7		
D	Vertical sides to columns	SM	8		
E	Edge of slab not exceeding 150mm girth	LM	15		
F	Edges of risers 75 - 150mm high	LM	14		
G	<b>Foundation Walling</b> <b>Natural quarry stone walling with a minimum of 7.0 N/mm<sup>2</sup> bedded and jointed in cement and sand (1:4) mortar, reinforced with and including 25 x 3 mm thick hoop iron strips at every alternate course as described in;</b> 200mm thick walls in foundations	SM	18		
H	<b>Pavings</b> Supply and lay 600 x 600 x 50mm reinforced concrete precast paving slabs around the building including laying, spreading and compacting 100mm thick approved sand bed blinding, on and including 150mm thick compacted hardcore to Engineer's approval.	SM	7		
J	<b>Plinth</b> <b>25mm Thick cement and sand (1:4) rendering on concrete or masonry ; wood float finished; to</b> Plinths externally	SM	5		
K	<b>Two coats black bitumastic paint on:</b> Rendered surfaces	SM	5		
	<b>Carried to collection</b>				

Item	Description	Unit	QTY		
	<p><b>COLLECTION</b></p> <p>Total brought forward from page no:</p> <p>Total brought forward from page no:</p> <p>Total brought forward from page no:</p>				
	<p><b><u>ELEMENT NO. 1</u></b>                      <b>Carried to</b></p> <p><b><u>SUBSTRUCTURES</u></b>                      <b>Main summary</b></p>				

Item	Description	Unit	QTY		
<b><u>PROPOSED GUARD HOUSE</u></b>					
<b>BILL NO.1-BUILDERS WORKS</b>					
<b>ELEMENT No 2 - R.C FRAME</b>					
<b>In- situ vibrated reinforced concrete Class 25 MPa: in:</b>					
A	Columns	CM	2		
B	Beams	CM	2		
C	150mm thick Roof Slab	SM	15		
<b>Ribbed reinforcement steel bars to KS 573:2014 : Grade 500 high tensile strength including bends, hooks, tying wire and distance blocks: to S.E's detail ( Provisional)</b>					
D	Assorted reinforcement	Kg	759		
<u>Modular steel frame with steel plates covering formwork and/or marine board formwork: to</u>					
E	Sides of columns	SM	27		
F	Sides and soffites of beams	SM	16		
G	Soffits of suspended slabs	SM	15		
H	Edges of slab over 150mm but not exceeding 225mm girth	LM	15		
	<b><u>ELEMENT NO. 2</u></b> <b><u>R.C FRAME</u></b>	Carried to	Main summary		

Item	Description	Unit	QTY		
	<b><u>PROPOSED GUARD HOUSE</u></b>				
	<b>BILL NO.1-BUILDERS WORKS</b>				
	<b>ELEMENT No 3-WALLING</b>				
	<b><u>WALLING</u></b>				
	<b><u>External Walling</u></b>				
	<i>Machine cut quarry stone walling with a minimum of 7.0 N/mm<sup>2</sup> average compressive strength; bedded and jointed in cement and sand (1:4) mortar, reinforced with and including 25 x 3 mm thick hoop iron strips at every alternate course as described in;</i>				
A	200mm thick walling Externally	SM	24		
B	200mm thick parapet walling	SM	6		
	<b><u>Internal Walling</u></b>				
	<i>Machine cut quarry stone walling with a minimum of 7.0 N/mm<sup>2</sup> average compressive strength; bedded and jointed in cement and sand (1:4) mortar, reinforced with and including 25 x 3 mm thick hoop iron strips at every alternate course as described in;</i>				
C	200mm thick walling Internally	SM	5		
D	150mm thick walling Internally	SM	0		
E	Approved hessian based damp proof course to 200mm thick walling in cement/sand mortar	LM	11		
F	Approved hessian based damp proof course to 150mm thick walling in cement/sand mortar	LM	0		
	<b><u>Precast Concrete Breeze Ventilation Blocks</u></b>				
G	150 x 150mm wide x 50mm thick Pre Cast Concrete flower 3D breeze ventilation blocks bedded and jointed in cement and sand (1:4) mortar	SM	0		
	<b>COPING</b>				
H	300 x 100mm insitu reinforced concrete class 20Mpa coping, throated and weathered and jointing to columns with cement sand 1:4 mortar	LM	11		
	<b>Lintols</b>				
I	200mm x 200mm Deep lintols in reinforced concrete class 20MPa with and including 4No T10 and T8 stirups at 200mm centres; complete with formwork	LM	2		
	<b><u>ELEMENT NO. 3</u></b>	<b>Carried to</b>			
	<b><u>WALLING</u></b>	<b>Main summary</b>			

Item	Description	Unit	QTY		
<b><u>PROPOSED GUARD HOUSE</u></b>					
<b>BILL NO.1-BUILDERS WORKS</b>					
<b>ELEMENT NO 4-WINDOWS</b>					
<b><u>MILD STEEL WINDOWS</u></b>					
<p><b>Supply, fabricate and fix the following purpose made small pane mild steel casement windows to be fabricated from approved mild steel sections (atleast 14g 2mm thick ) comprising of frame and casement incorporating permanent hooded high level ventilation panels infilled with mosquito gauze : window supplied complete with and including 12mm solid square burglar proofing bars fixed at 200mm centres both ways and metal fixing lugs including building into wall and making good, and all necessary iron mongery viz hinges, fasteners, and hasp including shop priming window with red oxide primer before delivery to site:-</b></p>					
<p><b>A prime cost sum of Kshs 4,500 per Sqm has been allowed for fabrication of the above specified Steel casement Windows by AHP juakali artisans as approved by the Project Manager/Architect.</b></p>					
<p><b>The contractor's unit rate shall include the cost of transport, storage, fixing and all associated accesories in addition to the PC Rate.</b></p>					
A	Window, overall size 1900 X 1500mm high to Architects Details	NO	1		
B	Ditto Size 650 x 1500mm high (bedroom)	NO	1		
C	Ditto Size 1000 x 1350mm high (Kitchen)	NO	0		
D	Ditto Size 600 x 900mm high (WC/SH)	NO	1		
<b><u>Glazing</u></b>					
E	4mm Thick clear sheet glass panes over 0.1 but not exceeding 0.5 square meters; fixing with premium putty	SM	4		
F	Ditto; obscure	SM	1		
<b><u>Painting and Decorations</u></b>					
<b><u>On Metal work</u></b>					
<p><b><u>Prepare and apply aerosol spray painting in one finishing coats of approved first grade to: -</u></b></p>					
G	General window and grille surfaces; over 300mm girth internal	SM	4		
<b>Carried to Collection</b>					



Item	Description	Unit	QTY		
A	<p><b>Precast concrete window cill finishing fair on all exposed surfaces and hoisting and placing in position, bedding, jointing and pointing in pigmented cement and sand (1:3) mortar</b></p> <p>150 x 25mm thick Precast concrete window sill</p> <p style="text-align: right;"><b>Carried to collection</b></p> <p style="text-align: center;"><b>COLLECTION</b></p> <p>Total brought forward from page no:</p> <p>Total brought forward from page no:</p>	LM	3		
	<p><b><u>ELEMENT NO. 4</u></b>                      <b>Carried to the</b></p> <p><b><u>WINDOWS</u></b>                              <b>Main summary</b></p>				

Item	Description	Unit	QTY		
	<b><u>PROPOSED GUARD HOUSE</u></b>				
	<b>BILL NO.1-BUILDERS WORKS</b>				
	<b>ELEMENT NO 5-DOORS</b>				
	<b><u>External Doors</u></b>				
	<b><u>Flush timber doors</u></b>				
	<b>50 mm thick Semi Solid cored flush doors with plywood facing to receive painting (m.s) all to Architects details, specifications and approval</b>				
	<b>A prime cost sum at the rate indicated below for fabrication of the above specified Timber Flush door leaves by AHP juakali artisans as approved by the Project Manager/Architect.</b>				
	<b>The contractor's unit rate shall include the cost of transport, storage, fixing and all associated accessories in addition to the PC Rate.</b>				
A	Door size 900mm x 2400mm High comprising of 1 No Opennable leaf size 800 x 2100mm high including fixed fanlight size 900 x 300mm high in 4mm clear glass ( measured separately) (PC Rate Kshs 4,000)	NO	2		
B	Ditto 800 x 2100mm high comprising of 1No. Opennable leaf size 700 x 2100mm high (PC Rate Kshs 3,500)	NO	0		
	<b>4mm Thick clear sheet glass fixing with matching timber glazing beads to timber frames</b>				
C	In panes exceeding 0.1 sqm but not exceeding 0.5 square metres.	SM	1		
	<i><u>Frames and frame finishes in cypress Timber</u></i>				
D	25 x 25mm quadrant (PC Rate Kshs 75)	LM	5		
E	25 x 50mm architrave with two labours, plugged (PC Rate Kshs 150)	LM	8		
F	150mm x 50mm transome with three labours; chamfered edges; plugged (PC Rate Kshs 800)	LM	8		
G	150mm x 50mm frame with three labours; chamfered edges; plugged (PC Rate Kshs 800)	LM	8		
	<b>Carried to collection</b>				

Item	Description	Unit	QTY		
	<u>Painting and decorating</u>				
	<u>Priming back of frame with an aluminium or equivalent and approved wood primer</u>				
A	Surfaces not exceeding 100mm girth	LM	13		
B	Surfaces over 100mm but not exceeding 200mm girth	LM	15		
	<u>Prepare Knot, prime, stop and apply one undercoat and two finishing coats first grade timber quality paint to wood surfaces as per the manufacturer's printed instructions</u>				
C	General timber surfaces	SM	9		
D	Surfaces over 200mm but not exceeding 300mm girth	LM	15		
E	Architraves: not exceeding 100 mm girth □	LM	8		
F	Quadrant beading : not exceeding 100 mm girth	LM	5		
	<b>Ironmongery</b>				
	<b>Supply and fix the following ironmongery to timber complete with matching screws and keys to the approval of the Architect</b>				
G	100mm pressed steel Butt Hinges	PRS	3		
H	Stainless steel 3 Lever Mortice Door Lock with handle furniture set;( keyhole escutcheons, cylinder and latch )	NO	0		
I	Ditto: but 2 Lever Door Lock with handle	NO	2		
J	Door fixing cramps	NO	0		
K	200 x 75 x 3mm perspex door signage with door numbers as per Architect detail	NO	2		
L	Block sign with block type, name and number in exterior quality paint as per Architect detail	NO	0		
	<b>Carried to Collection</b>				
	<b>COLLECTION</b>				
	Total brought forward from page no:				
	Total brought forward from page no:				
	<b>ELEMENT NO. 5</b>	<b>Carried to</b>			
	<b>DOORS</b>	<b>Main summary</b>			

Item	Description	Unit	QTY		
	<b><u>PROPOSED GUARD HOUSE</u></b>				
	<b>BILL NO.1-BUILDERS WORKS</b>				
	<b>ELEMENT NO 6 - EXTERNAL FINISHES</b>				
	<b>EXTERNAL WALL FINISHES</b>				
	<b>External Render</b>				
	<i>Cement and sand (1:3) render:wood floated: on concrete or blockwork: to</i>				
A	15mm thick to beams, Columns, Slab Moulds and walling externally	SM	7		
B	Extra over horizontal and vertical pointing in 10mm thick rod in cement and sand mix (1:3) mortar including one coat Bituminous paint	LM	29		
	<b>External Painting</b>				
	<i>Prepare and apply one coat Alkali Resistant primer followed by two finishing coats of silicon exterior Emulsion paint in accordance with the manufacturers written instructions and to the satisfaction of the architect to</i>				
C	Concrete/masonry surfaces externally-Beam, Column and Slab Moulds	SM	7		
	<b>ROOF FINISHES</b>				
	<b>Cement and sand (1:4) screeded beds: on concrete: complete with coloured pigmentation additives and hardener to:</b>				
D	50mm average waterproofed lightweight screed laid to falls and crossfalls to roof slabs -upper roof including gutter bases	SM	12		
	<i>Prepare and apply to vertical/ horizontal surfaces 4mm thick APP/EPDM water proofing or other equal and approved membrane with surface finish weighing 4kg/ sm; laid on primer with torch-on process ;by an approved specialist all in accordance with the manufacturers instructions including provision of a written ten (10) year anti leak guarantee.</i>				
E	4mm thick APP membrane applied to roof slabs	SM	12		
F	Ditto to skirting 200mm high	LM	11		
G	Dress membrane around 100mm rainwater outlet	No.	2		
	<i>The Following Flat roof concrete tiles fixed with approved adhesive, laid and jointed with waterproofing bituminous compound</i>				
H	20mm thick interlocking Concrete tiles of size 225 x 225mm	SM	12		
	<b>ELEMENT NO. 6</b>	<b>Carried to</b>			
	<b>EXTERNAL FINISHES</b>	<b>Main summary</b>			

Item	Description	Unit	QTY		
	<b><u>PROPOSED GUARD HOUSE</u></b>				
	<b>BILL NO.1-BUILDERS WORKS</b>				
	<b>ELEMENT NO 7 - INTERNAL FINISHES</b>				
	<b><u>Internal Wall Finishes</u></b>				
	<u>Cement and sand (1:3) backings</u>				
A	15mm thick to receive ceramic Wall tiles	SM	12		
B	To receive ceramic wall tiles (m.s.)	SM	24		
	<u>Ceramic wall tiles</u>				
	<u>Allow a Prime Cost supply rate of Ksh. 1000 per SM (Rate to include cost of purchase, transport, offload, storage, fixing including all necessary adhesives and accessories</u>				
C	Supply and Fix approved ceramic wall tiles on prepared backings(m.s) with proprietary adhesive; jointed and pointed in matching coloured proprietary grouting; including pvc spacers and expansion joint as necessary: all to Architect's approval. - Wall Surfaces	SM	12		
	<u>Ceramic wall tiles</u>				
	<u>Allow a Prime Cost supply rate of Ksh. 1000 per SM (Rate to include cost of purchase, transport, offload, storage, fixing including all necessary adhesives and accessories</u>				
D	Supply and Fix approved ceramic wall tiles on prepared backings(m.s) with proprietary adhesive; jointed and pointed in matching coloured proprietary grouting; including pvc spacers and expansion joint as necessary: all to Architect's approval. - Wall Surfaces	SM	24		
	<u>15mm (minimum) two coat cement, sand (1:3) plaster complete with wire gauze anti-crack mechanism at the intersection of masonry walling and concrete beams as described to:-</u>				
E	Concrete/masonry surfaces	SM	8		
	<b><u>Painting and Decoration</u></b>				
	<u>Prepare, Skim and apply Emulsion or universal undercoat followed by two finishing coats of soft satin Emulsion paint in accordance with the manufacturers written instructions and to the satisfaction of the architect to</u>				
F	Plastered concrete/masonry surfaces internally	SM	8		
	<b>Carried to Collection</b>				

Item	Description	Unit	QTY		
A	<p><b><u>Ceiling finishes</u></b></p> <p><u>15mm (minimum) two coat cement, sand (1:3) plaster complete with wire gauze anti-crack mechanism at the intersection of masonry walling and concrete beams as described to:-</u></p> <p>Soffits of Concrete surfaces</p> <p><u>Painting and Decoration</u></p> <p><u>Prepare, Skim and apply Emulsion or universal undercoat followed by two finishing coats of soft satin Emulsion paint in accordance with the manufacturers written instructions and to the satisfaction of the architect to</u></p>	SM	12		
B	Plastered ceilings	SM	12		
	<b>Carried to Collection</b>				

Item	Description	Unit	QTY		
	<p style="text-align: center;"><b>COLLECTION</b></p> <p>Total brought forward from page no:</p>  <p>Total brought forward from page no:</p>				
	<p><b>ELEMENT NO. 7</b> Carried to <b>INTERNAL FINISHES Main summary</b></p>				

Item	Description	Unit	QTY		
<b><u>PROPOSED GUARD HOUSE</u></b>					
<b>BILL NO.1-BUILDERS WORKS</b>					
<b>MAIN SUMMARY</b>					
1	<b>Substructures</b>				
2	<b>Reinforced Concrete Frame</b>				
3	<b>Walling</b>				
4	<b>Windows</b>				
5	<b>Doors</b>				
6	<b>External Finishes</b>				
7	<b>Internal Finishes</b>				
<b><u>TOTAL FOR 1NO. GUARD HOUSE</u></b>					
<b>NO. OF BLOCKS</b>					
MULTIPLY BY <b>7.NO</b> OF GUARD HOUSE					
<b><u>TOTAL FOR GUARD HOUSE CARRIED TO GRAND SUMMARY</u></b>		<b>X 7</b>			7



**GARBAGE RECEPTACLE**

Item	Description	Unit	QTY	RATE	AMOUNT
<b><u>PROPOSED GARBAGE RECEPTACLE</u></b>					
<b>BILL NO.1-BUILDERS WORKS</b>					
<b>ELEMENT NO 1 - SUBSTRUCTURES (ALL PROVISIONAL)</b>					
<i>Site Clearance</i>					
A	Clear site of all grass, hedges, shrubs, bushes grub up roots, load and remove from site and dispose at designated local authority areas.	SM	112		
B	Excavate average 300mm deep to remove top vegetable soil, load, remove from site and dump in designated local authority dump site.	SM	112		
C	Excavate for Strip foundations depth not exceeding 1.50 metres starting from Reduced ground levels.	CM	68		
D	Ditto to column bases	CM	4		
D	Extra over all type of excavation for excavating in soft rock	CM	7		
E	Ditto excavation in hard rock class I	CM	0		
<b>Disposal of water</b>					
F	Allow for keeping the whole of the excavation free from all spring and running water by pumping or any other such means as may be necessary	Item			
<b>Planking and strutting</b>					
G	Allow for maintaining and upholding the sides of excavations and keeping excavations clear of all fallen materials, rubbish etc	Item			
<b>Carried to collection</b>					

Item	Description	Unit	QTY	RATE	AMOUNT
	<b><u>Disposal of excavated material</u></b>				
A	Load, wheel and cart away surplus excavated material to a Local Authority designated dumping site or fill soil heaps as away from site instructed by the Project Engineer.	CM	2		
B	Return, fill and ram selected excavated material around sides of foundations.	CM	70		
	<b>Fillings</b>				
C	Make up levels using approved imported materials: compacted in layers not exceeding 300mm thick with a roller: to the satisfaction of the Structural Engineer.	CM	0		
D	300mm thick hardcore bed: hand packed : compacted in layers not exceeding 150mm thick: to the satisfaction of the Structural Engineer	SM	112		
E	50 mm Stone dust/ Murrum blinding to surfaces of hardcore	SM	112		
	<b>Anti - termite to treatment</b>				
F	Approved anti-termite treatment, with ten-year guarantee, sprayed to surfaces of hardcore strictly in accordance with manufacturer's instructions.	SM	112		
	<b>Damp-proof membrane</b>				
G	1000 gauge polythene or other equal and approved damp-proof membrane, laid over blinded hardcore (measured separately) with 300mm side and end laps (measured nett-allow for laps); 1 No. layer: bedded in and including cement and sand (1:3) mortar	SM	112		
	<b>Concrete Blinding</b>				
	<b>In situ concrete Class 15MPa: vibrated:</b>				
H	50 mm thick blinding under column bases	SM	14		
I	50 mm thick blinding under strip foundations	SM	45		
	<b>In- situ vibrated reinforced concrete Class 25 MPa: in:</b>				
J	Column bases	CM	4		
K	Strip foundations	CM	9		
L	100mm thick surface bed	SM	112		
M	Columns	CM	1		
	<b>Carried to collection</b>				

Item	Description	Unit	QTY	RATE	AMOUNT
A	<b>Ribbed reinforcement steel bars to KS 573:2014 : Grade 500 high tensile strength including bends, hooks, tying wire and distance blocks: to S.E's detail ( Provisional)</b> Assorted reinforcement	KGS	812		
B	<b>Mesh fabric reinforcement to KS/EAS 412;2 (2019) BRC A142;200 x 200mm, weighing 2.22kg/m<sup>2</sup> (measured net - no allowance) for laps; in two layers - top &amp; bottom; including bends, tying wire and spacer blocks</b> In ground floor slab	SM	112		
	<u>Modular steel frame with steel plates covering formwork and/or marine board formwork: to:</u>				
C	Sides of column bases	SM	17		
D	Sides of Strip foundations	SM	30		
E	Vertical sides to columns	SM	17		
F	Edge of slab not exceeding 150mm girth	LM	43		
	<b>Foundation Walling</b>				
	<b>Natural quarry stone walling with a minimum of 7.0 N/mm<sup>2</sup> bedded and jointed in cement and sand (1:4) mortar, reinforced with and including 25 x 3 mm thick hoop iron strips at every alternate course as described in;</b>				
G	200mm thick walls in foundations	SM	98		
	<b><u>Pavings</u></b>				
H	Supply and lay 600 x 600 x 50mm reinforced concrete precast paving slabs around the building including laying, spreading and compacting 100mm thick approved sand bed blinding, on and including 150mm thick compacted hardcore to Engineer's approval.	SM	45		
	<b><u>Plinth</u></b>				
	<b><u>25mm Thick cement and sand (1:4) rendering on concrete or masonry ; wood float finished; to</u></b>				
J	Plinths externally	SM	30		
	<b>Two coats black bitumastic paint on:</b>				
K	Rendered surfaces	SM	30		
	<b>Carried to collection</b>				
	<b>COLLECTION</b>				
	Total brought forward from page no:				
	Total brought forward from page no:				
	Total brought forward from page no:				
	<b><u>ELEMENT NO. 1</u></b>	<b>Carried to</b>			
	<b><u>SUBSTRUCTURES</u></b>	<b>Main summary</b>			

Item	Description	Unit	QTY	RATE	AMOUNT
	<b><u>PROPOSED GARBAGE RECEPTACLE</u></b>				
	<b>BILL NO.1-BUILDERS WORKS</b>				
	<b>ELEMENT No 2 - R.C FRAME</b>				
	<b>In- situ vibrated reinforced concrete Class 25 MPa: in:</b>				
A	Columns	CM	1		
B	Beams	CM	5		
	<b>Ribbed reinforcement steel bars to KS 573:2014 : Grade 500 high tensile strength including bends, hooks, tying wire and distance blocks; to S.E's detail ( Provisional)</b>				
C	Assorted reinforcement	Kg	783		
	<u>Modular steel frame with steel plates covering formwork and/or marine board formwork: to</u>				
D	Sides of columns	SM	27		
E	Sides and soffites of beams	SM	45		
	<b><u>ELEMENT NO. 2</u></b>				
	<b><u>R.C FRAME</u></b>				
	<b>Carried to Main summary</b>				

Item	Description	Unit	QTY	RATE	AMOUNT
	<b><u>PROPOSED GARBAGE RECEPTACLE</u></b>				
	<b>BILL NO.1-BUILDERS WORKS</b>				
	<b>ELEMENT No 3-WALLING</b>				
	<b><u>WALLING</u></b>				
	<b><u>External Walling</u></b>				
	<i><u>Machine cut quarry stone walling with a minimum of 7.0 N/mm<sup>2</sup> average compressive strength; bedded and jointed in cement and sand (1:4) mortar, reinforced with and including 25 x 3 mm thick hoop iron strips at every alternate course as described in;</u></i>				
A	200mm thick walling Externally	SM	97		
	<b><u>Internal Walling</u></b>				
	<i><u>Machine cut quarry stone walling with a minimum of 7.0 N/mm<sup>2</sup> average compressive strength; bedded and jointed in cement and sand (1:4) mortar, reinforced with and including 25 x 3 mm thick hoop iron strips at every alternate course as described in;</u></i>				
B	200mm thick walling Internally	SM	70		
C	Approved hessian based damp proof course to 200mm thick walling in cement/sand mortar	LM	75		
	<b><u>ELEMENT NO. 3</u></b>				
	<b><u>WALLING</u></b>				
	<b>Carried to Main summary</b>				

Item	Description	Unit	QTY	RATE	AMOUNT
A	<p align="center"><b><u>PROPOSED GARBAGE RECEPTACLE</u></b></p> <p align="center"><b>BILL NO.1-BUILDERS WORKS</b></p> <p><b>ELEMENT NO 4-ROOF</b></p> <p>IT5 roofing sheets on steel trusses (m/s) with approved galvanised hook bolts, nuts and washers including side and end laps fixed to and including 100x50x4mm rafters spaced at 900mm c/c with 50x50x3mm SHS purlins at 600x600mm c/c with and including all welded and bolted connections : delivery to site and erection with and including one shop coat red oxide, zinc chromate or similar approved primer: complete to manufacturer's specifications</p>	SM	101		
	<p><b><u>ELEMENT NO. 4</u></b>                      <b>Carried to the</b>  <b>ROOF</b>                                      <b>Main summary</b></p>				

Item	Description	Unit	QTY	RATE	AMOUNT
<b><u>PROPOSED GARBAGE RECEPTACLE</u></b>  <b>BILL NO.1-BUILDERS WORKS</b>  <b>ELEMENT NO 5-DOORS</b>  <b><u>External Doors</u></b>  <b><u>Steel Casement Door</u></b>  <b>Heavy gauge double steel louvered door, all primed with red oxide and spray painted 2 coats eggshell gloss paint; complete with hinges, stays, fasteners and necessary seremetals assembled and fixed to opening including cutting and pinning lugs to concrete or block work sorroung and bedding frame in cement and sand mortar (1:3).</b>					
A	Double leaf door size 1600 x 2100mm high	NO	2		
B	Ditto overall Size 1200 x 2400mm high	NO	4		
	<b><u>ELEMENT NO. 5</u></b> <b><u>DOORS</u></b>	Carried to	Main summary		



Item	Description	Unit	QTY	RATE	AMOUNT
	<b><u>PROPOSED GARBAGE RECEPTACLE</u></b>				
	<b>BILL NO.1-BUILDERS WORKS</b>				
	<b>ELEMENT NO 6 - EXTERNAL FINISHES</b>				
	<b>EXTERNAL WALL FINISHES</b>				
	<b>External Render</b>				
	<i>Cement and sand (1:3) render:wood floated: on concrete or blockwork: to</i>				
A	15mm thick to beams, Columns, Slab Moulds and walling externally	SM	23		
B	Extra over horizontal and vertical pointing in 10mm thick rod in cement and sand mix (1:3) mortar including one coat Bituminous paint	LM	97		
	<b>External Painting</b>				
	<i>Prepare and apply one coat Alkali Resistant primer followed by two coats of silicon exterior Emulsion paint in accordance with the manufacturers written instructions and to the satisfaction of the architect to</i>				
C	Concrete/masonry surfaces externally-Beam, Column and Slab Moulds	SM	23		
	<b>ELEMENT NO. 6</b> Carried to				
	<b>EXTERNAL FINISHES</b> Main summary				

Item	Description	Unit	QTY	RATE	AMOUNT
	<b><u>PROPOSED GARBAGE RECEPTACLE</u></b>				
	<b>BILL NO.1-BUILDERS WORKS</b>				
	<b>ELEMENT NO 7 - INTERNAL FINISHES</b>				
	<b><u>Internal Wall Finishes</u></b>				
	<u>Cement and sand (1:4) backings</u>				
A	32mm Thick coloured cement sand screed mix 1:3 finished to approval	SM	98		
	<u>15mm (minimum) two coat cement, sand (1:3) plaster complete with wire gauze anti-crack mechanism at the intersection of masonry walling and concrete beams as described to:-</u>				
B	Concrete/masonry surfaces	SM	237		
	<b><u>Floor Finishes</u></b>				
	<u>Cement and sand (1:3) screeds, backings, beds etc</u>				
C	32mm Thick coloured cement sand screed mix 1:3 finished with red oxide to approval	SM	98		
	<b><u>ELEMENT NO. 7</u></b> Carried to				
	<b>INTERNAL FINISHES Main summary</b>				

Item	Description	Unit	QTY	RATE	AMOUNT
<b>BILL NO.1-BUILDERS WORKS MAIN SUMMARY</b>					
1	<b>Substructures</b>				
2	<b>Reinforced Concrete Frame</b>				
3	<b>Walling</b>				
4	<b>Roof</b>				
5	<b>Doors</b>				
6	<b>External Finishes</b>				
7	<b>Internal Finishes</b>				
<b><u>TOTAL FOR 1NO. GARBAGE RECEPTACLES</u></b>					
<b>NO. OF BLOCKS</b>					
MULTIPLY BY <b>5.NO</b> OF RECEPTACLES		<b>X 5</b>			5
<b><u>TOTAL FOR GARBAGE RECEPTACLES CARRIED TO GRAND SUMMARY</u></b>					

**BOUNDARY WALL**

ITEM	DESCRIPTION	QTY	UNIT	RATE	AMOUNT
	<b><u>BOUNDARY WALL</u></b>				
	<b><u>ELEMENT NO.1</u></b>				
	<b><u>SUBSTRUCTURES</u></b>				
	<b><u>(ALL PROVISIONAL)</u></b>				
	<b><u>Siteworks and Excavations</u></b>				
A	Clear site of all grass, hedges, shrubs, bushes including grubbing up of roots, cart away arising debris and burn them.	SM	0		
	<b><u>Excavations</u></b>				
B	Excavate for Strip foundations depth not exceeding 1.50 metres starting groundlevel	CM	0		
C	Ditto to column base	CM	28		
E	Extra over excavation for excavating in soft rock	CM	3		
F	Extra over excavation for excavating in Hard rock class type 1	CM	1		
	<b><u>Disposal of water</u></b>				
G	Allow an item for keeping all excavations free from all spring and running water by pumping or any other such means.	ITEM	1		
	<b><u>Planking and strutting</u></b>				
H	Allow an item for maintaining and upholding the sides of excavations and keeping excavations clear of all fallen materials.	ITEM	1		
	<b>Carried to Collection</b>				

ITEM	DESCRIPTION	QTY	UNIT		
<b>SUBSTRUCTURES-(CONTINUED)</b>					
<b>Disposal of excavated materials</b>					
A	Return, fill and ram selected excavated material around foundations.	CM	29		
B	Load,wheel and cart away surplus excavated material away from site	CM	-1		
<b>In situ concrete Class 15MPa: vibrated:</b>					
C	50mm Thick blinding to strip foundation	SM	0		
D	Ditto to column bases	SM	28		
<b>In- situ vibrated reinforced concrete Class 20 MPa: in:</b>					
E	Strip footing	CM	0		
F	Ditto to column bases	CM	0		
G	Columns	CM	-6		
<b>Carried to Collection</b>					

ITEM	DESCRIPTION	QTY	UNIT		
	<b><u>SUBSTRUCTURES-(CONTINUED)</u></b>				
	<b>Modular steel frame with steel plates covering formwork and/or marine board formwork: to:</b>				
A	Sides of strip footing	SM	0		
B	Ditto colum bases	SM	0		
	<b>Ribbed reinforcement steel bars to KS 573:2014 : Grade 500 high tensile strength including bends, hooks, tying wire and distance blocks; to S.E's detail ( Provisional)</b>				
C	Assorted Reinforcement (8 - 16mm bars)	KG	-1008		
	<b>Foundation Wall</b>				
	<b>Natural quarry stones rough dressed with a minimum compressive strength of 7.0N/mm<sup>2</sup> ;bedded and jointed in cement and sand(1:4) mortar;reinforced with 25 x 3mm thick iron strips at alternate courses.</b>				
D	200mm Thick walling	SM	0		
	<b>Carried to Collection</b>				

ITEM	DESCRIPTION	QTY	UNIT		
	<u>COLLECTION</u>  FROM PAGE BW/1  FROM PAGE BW/2  FROM PAGE BW/3				
	<b>TOTAL FOR ELEMENT NO. 1</b> <b>(SUBSTRUCTURES)</b>	<b>CARRIED TO</b> <b>SUMMARY</b>	<b>KSHS</b>		



ITEM	DESCRIPTION	QTY	UNIT		
	<b><u>ELEMENT NO. 2</u></b>				
	<b><u>REINFORCED CONCRETE SUPERSTRUCTURE</u></b>				
	<b>In- situ vibrated reinforced concrete Class 20 MPa: in:</b>				
A	Columns	CM	6		
B	Ring Beam	CM	0		
	<b>Modular steel frame with steel plates covering formwork and/or marine board formwork: to:</b>				
C	Vertical sides of columns	SM	74		
	<u>Ribbed reinforcement steel bars to KS 573:2014 : Grade 500 high tensile strength including bends, hooks, tying wire and distance blocks; to S.E's detail ( Provisional)</u>				
D	Assorted Reinforcement (8 - 16mm bars)	KG	756		
	<b>TOTAL FOR ELEMENT NO. 2 CARRIED TO</b>				
	<b>(REINFORCED CONCRETE) SUMMARY</b>				

ITEM	DESCRIPTION	QTY	UNIT		
	<p><b><u>ELEMENT NO. 3</u></b></p> <p><b><u>WALLING</u></b></p> <p><u>Machine cut quarry stone walling with a minimum of 7.0 N/mm<sup>2</sup> average compressive strength to B.S 5390;bedded and jointed in cement and sand (1:4) mortar, reinforced with and including 25 x 3 mm thick hoop iron strips at every alternate course as described in;</u></p>				
A	200mm Thick walling	SM	0		
	<p><b>Precast concrete class 20/20 coping as described in;</b></p>				
B	600 x 350 wide x 100mm thick insitu cast reinforced concrete coping, throated and weathered and jointing to columns with cement sand 1:4 mortar	NO	28		
C	Ditto 300 x 100mm concrete coping to walls twice weathered and throated;	LM	0		
	<p><b>TOTAL FOR ELEMENT NO. 3 CARRIED TO (WALLING) SUMMARY</b></p>				

ITEM	DESCRIPTION	QTY	UNIT		
	<b><u>ELEMENT NO. 4</u></b>				
	<b><u>EXTERNAL FINISHES</u></b>				
A	Extra over walling for smooth chisel dressing with flush pointed vertical joints and recessed horizontal joints 10 mm rod in cement and sand mix (1:3) mortar including one coat of Bituminous paint  <u>15mm (minimum) two coat lime plaster complete with wire gauze anti-crack mechanism at the intersection of masonry walling and concrete beams as described to:-</u>	SM	0		
B	Columns	SM	47		
C	Ring beam	SM	0		
	<b>GATES</b>				
	<b>Mild steel sections as described in;</b>				
D	6000mm wide x 2400mm high double gate comprising of 50x50x3mm RHS framing and middle rail 50x25x3mm RHS Vertical infill members at 225mm centres;priming with red oxide primer; purpose made ironmongery; all necessary lugs and grouting as per details (all with roller at the ground)	NO	14		
E	Ditto pedestrian gate size 900x1800 ditto  Green Fencing with Chainlink	NO	14		
F	2400mm High chainlink fencing : comprising 16 gauge chainlink fixed to and including precast concrete posts :holes for and including 8No strands 16 gauge galvanised barbed wire : 16 gauge high tensile galvanised straining vertical wire at 250 centres : 700 x 600 x 650mm deep plain concrete (class 20) base at 3000mm centres : strutting posts : including planting and maintenace to maturity of bouganvillea shrubs along the fenceline; all necessary excavations and disposal	LM	2755		
	<b>TOTAL FOR ELEMENT NO. 4 CARRIED TO (EXTERNAL FINISHES) SUMMARY</b>				

ITEM	DESCRIPTION				
<b><u>SECTION SUMMARY - BOUNDARY WALL</u></b>					
1	<b>SUBSTRUCTURES FROM PAGE.....</b>	BW/4			
2	<b>R.C. SUPERSTRUCTURE FROM PAGE.....</b>	BW/5			
3	<b>WALLING FROM PAGE.....</b>	BW/6			
4	<b>EXTERNAL FINISHES FROM PAGE.....</b>	BW/7			
<b>TOTAL FOR BOUNDARY WALL CARRIED TO GRAND SUMMARY</b>					

---

## **CIVIL WORKS (ROADS)**

---

ITEM	DESCRIPTION	QTY	UNIT	RATE	AMOUNT
<b><u>Preliminary and General Items</u></b>					
A	Allow Provisional sum of Kenya shillings (KSh 200,000/=) for materials testing as instructed by the Engineer.	Prov. Sum	1	200,000.00	200,000.00
B	Extra Over on Item 1.01 for Contractors overheads and profits	%			
<b>Carried to Collection</b>					

ITEM	DESCRIPTION	QTY	UNIT	RATE	AMOUNT
<b><u>Site Clearance and Topsoil Stripping</u></b>					
A	Clear site including removal of trees (girth less than 300 mm), hedges, bushes and other vegetation and other deleterious materials, grub up roots and backfilling of holes left by removal of stumps and roots in accordance with the Specifications, as shown on the drawings and as instructed by Engineer.	m2	0.00		
B	Removal of top soil to a maximum depth of 200 mm including excavation, loading and disposal	m3	0.00		
C	Cutting of trees of all girth above 300 mm including cutting of trunks, branches, uprooting and removal of all materials and stacking within the Right of Way and complete with filling of depressions/pits by earth including liaison with concerned authorities for obtaining permissions.				
	(i) Girth from 300 mm to 600 mm	No	3.00		
	(ii) Girth above 600 mm but up to 900 mm	No	4.00		
	(iii) Girth above 900 mm but up to 1800 mm	No	5.00		
D	Transpotation of the existing trees of girth above 600 mm girth as instructed by Engineer, including shifting of the tree and storing at locations as instructed by the Engineer.	No	3.00		
<b>Carried to Collection</b>					

ITEM	DESCRIPTION	QTY	UNIT	RATE	AMOUNT
	<b><u>Earthworks</u></b>				
	No separate payments shall be made for the overhaul of the material and the cost of such haulage shall be included in the rates and or prices.				
A	Cut to spoil in soft material	m3		5114.00	
B	As Item 5.01 but in hard material	m3		511.00	
C	Provide, Spread and compact rockfill in swampy areas	m3		0.00	
	<b>Carried to Collection</b>				



ITEM	DESCRIPTION	QTY	UNIT	RATE	AMOUNT
	<b><u>Culvert and Drainage Works</u></b>				
	No separate payment shall be made for the haulage of surplus or unsuitable excavated material and the cost of such haulage shall be included in the rates and/or prices				
A	Excavate in soft material for pipe culverts, subsoil drains, headwalls, wing walls, aprons, toe walls, drop inlets, mitre drains, catch water drains and median drains including support of trench sides, backfilling and compacting as specified or as instructed by the Engineer.	m3		1830.00	
B	As Item 8.01 but in hard material (any method)	m3		183.00	
C	Allow for hacking in existing concrete drain for junction connections	m3		10.00	
D	Allow for perforation and connecting to the existing drain including stoppage of inflowing water (hole approximately 600 wide x 800 high x 250 thick)	no.		4.00	
E	Provide, lay and joint 450 mm Internal Diameter (I. D.) Reinforced Cement Concrete pipes. The rate to include excavation, backfilling and compaction to drain formation level	m		120.00	
F	Ditto item 8.06 above but 600mm I.D. Reinforced Cement Concrete pipes	m		60.00	
G	Ditto item 8.06 above but 900mm I.D. Reinforced Cement Concrete pipes	m		20.00	
H	Provide place and compact class 25/20 concrete to headwalls, wingwalls, aprons and toe walls to pipe culverts.	m3		40.00	
J	Provide place and compact 150mm class 15/20 concrete to beds and surround to 450mm diameter pipes	m3		34.00	
K	Ditto item 8.11 above but 600mm I.D. Reinforced Cement Concrete pipes	m3		23.00	
L	Ditto item 8.11 above but 900mm I.D. Reinforced Cement Concrete pipes	m3		11.00	
M	Provide and joint 450mm diameter precast concrete invert block drain (IBD) channels with two double side precast side slabs of 600x225x75mm as lining for side drain including bedding and backfilling with selected material as directed by the Engineer.	m		1830.00	
N	Provide and lay 450 Dia service ducts of length 10 m each as per the drawings and as instructed by the Engineer; Rate to include excavation, disposal of excavated material and concrete surround	No.		20.00	
	<b>Carried to Collection</b>				

ITEM	DESCRIPTION	QTY	UNIT		
	<p><b><u>Natural Material for Sub-base and Base</u></b></p> <p>Measurements and payment by method 'A' as defined in the standard specifications. No separate payments shall be made for the overhaul of material and the cost of such haulage shall be included in the rates and or prices</p>				
A	Provide, place, water and compact Natural Gravel Material to 95% MDD (AASHTO T180) of sub base quality for base for the walkways of thickness 100mm and on the carriageway and parking to a consolidated thickness of not more than 300mm as shown in the drawings and as instructed by the Engineer	m3	7783.00		
B	Prepare surface provide, place, handpack (200mm in one layer)and compact quarry chips (natural blue stone) to refusal densities on the carriageway and parking as directed by the Engineer.	m3	3892.00		
	<b>Carried to Collection</b>				

ITEM	DESCRIPTION	QTY	UNIT	RATE	AMOUNT
	<b><u>Concrete Works</u></b>				
A	Provide and fix on the carriageway and parking interlocking concrete paved unishaped blocks (monolithic single layer precast concrete blocks) of any	m2		10227.00	
B	Extra over item 17.01 for laying blocks at speed bumps	m2		20.00	
C	Ditto item 17.01 above but for 60mm heavy duty blocks at the walkway	m2		1373.00	
D	Provide, lay in place and joint 600x600x50mm well cured paving slabs on 50mm well compacted sand/quarry dust bed to footpaths/islands, Cloth drying areas and around the blocks as stipulated in the special Specifications.	m2		1373.00	
	<b>Carried to Collection</b>				

ITEM	DESCRIPTION	QTY	UNIT	RATE	AMOUNT
	<b><u>Road Furniture</u></b>				
	<b>Road Marking and Road Signs</b>				
	<b>Road Marking</b>				
A	Provide and lay hot applied thermoplastic road marking compound in approved colour and shade (ASTM 9) for road marking on bituminous surface on centerline, 100 mm, edge line 150 mm wide 3.0 mm thick, using fully automatic extrusion machine and using pre-melter for melting thermoplastic material including cleaning the surface of all dirt, dust, and other foreign matter, complete with demarcation at site/pre-marking, finishing and managing the traffic movements. Marking to be done as per the specifications, detailed drawings and as instructed by the Engineer.				
	(i) For lane marking (broken lines) with white paint, 100 mm wide	m2		253.00	
	(ii) For lane marking with yellow paint, 100mm wide	m2		0.00	
	(iii) For raised kerb lines with black paint, 150 mm wide	m2		275.00	
	<b>Other Road Furniture</b>				
B	Provide, lay and Joint complete with hauncing as shown on the drawings and as instructed by the Engineer				
	(i) Raised Kerbs	m		4260.00	
	(ii) Flush Kerbs	m		2430.00	
C	Provide, lay and Joint complete with hauncing as shown on the drawings and as instructed by the Engineer 100 x 125 mm channels for the walkways and shallow drains	m		6690.00	
	<b>Carried to Collection</b>				

ITEM	DESCRIPTION	QTY	UNIT	RATE	AMOUNT
1	Preliminary and General Items				
2	Site Clearance and Topsoil Stripping				
3	Earthworks				
4	Culverts and Drainage Works				
5	Natural Material for Sub-base and Base				
6	Concrete Works				
7	Road Furniture				
	<b>TOTAL FOR BOUNDARY WALL CARRIED TO GRAND SUMMARY</b>				

**CIVIL WORKS (SEWER)**

Item	Description	Unit	Quantity	Rate	Amount
	<p><b>BILL NO. 1.1 - PRELIMINARIES AND GENERAL ITEMS</b></p> <p><b>CLASS A - GENERAL ITEMS</b></p> <p><b>Contractual Requirements</b></p> <p>Provide for preparation and submission to the employer  1No set of virograph and 2No sets of blue print copies (A1 SIZE) of as built drawings for all the sewer pipelines in the contract. Note that manhole positions in the layout should be actual ( geo-referenced to the national grid).</p> <p><b>Specified Requirements</b></p> <p><b>Testing of Materials and Works</b></p> <p>Provide for concrete strength test. Rate to include for casting of the necessary number of cubes, curing,transport from site to testing institution and fees payable for the service.</p> <p>Provide for testing of the sewer pipes.Rate to include for transportation to the testing institutions and fees payable for this service.</p> <p><b>Temporary Works</b></p> <p>Traffic regulation (including signages,warning tapes and warning signs); establishment, operation and removal.</p>	sum	1		
A		nr	5		
B		nr	5		
C		nr	5		
D		Item	Sum		
	<b>Bill No. 1.1- PAGE 1 TOTAL CARRIED TO GRAND SUMMARY</b>				

Item	Description	Unit	Quantity	Rate	Amount
	<b>BILL No. 1.2 MEASURED WORKS</b>				
	<b>The rates quoted by the Contractor shall be deemed to include provision by the Contractor to provide temporary vehicular access to all construction sites including negotiating with private land owners and paying the necessary charges as required.</b>				
	<b>CLASS A - GENERAL ITEMS</b>				
	<b>GENERAL CLEARANCE</b>				
A	Allow for setting out of the works	m	1,920		
	<b>Testing of the works</b>				
B	Carrying out test on sewer, a pipeline as specified or directed by the engineer, include provision of all equipment and materials	m	1,920		
C	Allow for keeping trenches and other excavation free of water which may have entered through ground seepage, rain or by other means as directed by the Engineer	sum	1		
	<b>CLASS B - SITE INVESTIGATION</b>				
D	Trial holes where ordered to prove location , construction size etc., of pipelines, services or existing structures, max depth n.e 1m ( provisional)	nr	3		
E	Trial holes where ordered to prove location , construction size etc., of pipelines, services or existing structures, max depth 1- 2m ( provisional)	nr	3		
	<b>CLASS I - PIPEWORK - PIPES</b>				
	<b>Supply of pipes</b>				
F	<b>Nomial bore 150mm uPVC Class 34 Pipeline</b>	m	1,920		
	<b>uPVC &amp; PRECAST CONCRETE PIPES TO WITH SPIGOT AND SOCKET CONCRETE PIPES</b>				
	<b>The rates entered against the items in this section shall include for stripping top soil, laying aside and subsequently replacing over refilled trench, excavation in trench in material other than rock, shuttering where necessary, refilling and compacting spreading surplus soil evenly over and alongside pipe trench, compacting, lay and joint pipes to correct line and level. Depths are stated from ground level to invert level.</b>				
	<b>Nominal bore 150 mm in trenches</b>				
G	depth not exceeding 1.5 m.	m	1,920		
	<b>Bill No. 1.2- PAGE 2 TOTAL CARRIED FORWARD TO COLLECTION SHEET</b>				



Item	Description	Unit	Quantity	Rate	Amount
	<p><b>CLASS K - PIPEWORK - MANHOLES AND PIPEWORK ANCILLARIES</b></p> <p>Excavation quantities are given net. The rate entered are to include for manhole concrete slabs and covers, step irons or ladder, excavation, shuttering where necessary, refilling and compacting around the finished manholes, and disposing of surplus spoil is to be evenly spread. Excavation in any material other than rock</p> <p><b>Masonry manhole 1050 mm , reinforced concrete manhole slab and cover.</b></p>				
A	depth not exceeding 0.9 m.	nr	90		
B	depth not exceeding 1.2 m.	nr	90		
	<p><b>CLASS L; SUPPORTS AND PROTECTION ANCILLIARIES TO LAYING AND EXCAVATION</b></p> <p><b>Extras to Excavation and backfilling Trenches</b></p> <p><b>( Note : blasting not allowed for any rock excavation)</b></p> <p><b><i>In pipe trenches 150 mm bore</i></b></p>				
C	Excavation of rock	m3	960		
D	Allow for excavation of soft material below final surface of pipe trench and back fill with approved hardcore, well compacted in ,layers of 200mm thickness , depth not exceeding 1.0m	m3	384		
	<p><b><i>In Manholes and other chambers</i></b></p> <p><b>( Note: Blasting not allowed for any rock excavation )</b></p>				
E	Excavation of rock	m3	311		
F	Allow for excavation of soft material below final surface of manhole and back fill with approved hardcore, well compacted in ,layers of 200mm thickness , depth not exceeding 1.0m	m3	130		
	<p><b>Bed, Haunches and Surrounds</b></p> <p><b><i>Mass concrete grade 15/20 in 150mm Thick Beds, Haunches and surrounds</i></b></p>				
G	150 mm nominal bore pipeline Bed haunch and surround type D (0.2821 m³)	m	1,920		
	<b>Bill No. 1.2- PAGE 3 TOTAL CARRIED FORWARD TO COLLECTION SHEET</b>				

Item	Description	Unit	Quantity	Rate	Amount
	<b>COLLECTION PAGE</b>				
	<b>COLLECTION PAGE</b>				
1	<b>From Page CS/2</b>				
2	<b>From Page CS/3</b>				
	<b>Bill No. 1.2-TOTAL CARRIED FORWARD TO GRAND SUMMARY</b>				

Item	Description	Unit	Quantity	Rate	Amount
	<p><b>BILL No. 1.3. WASTE WATER TREATMENT/WASTE WATER DISPOSAL</b></p> <p>Provide a provisional sum for civil works associated with waste water treatment plant/waste water disposal to be executed as authorized by the Engineer and to be measured and valued by the Quantity Surveyor in accordance with the Contract</p>	sum	1	52,480,000	
B	<p>Provide a provisional sum for equipping of 2No. 3500PE Capacity Waste Water Treatment Plant to be executed as authorized by the Engineer in accordance with the Contract</p>	sum	1	65,600,000	
	<p><b>Bill No. 1.3-TOTAL CARRIED FORWARD TO GRAND SUMMARY</b></p>				

Item	Description	Unit	Quantity	Rate	Amount
	<b>SUMMARY</b>				
			<b>PAGE</b>		
<b>Bill No.</b> 1.1	Preliminaries and General Items		CS/1		
<b>Bill No.</b> 1.2	Measured Works		CS/7		
<b>Bill No.</b> 1.3	Biodigester		CS/8		
<b>GRAND TOTAL FOR CIVIL WORKS (SEWER) CARRIED TO GRAND SUMMARY</b>					

# **UNDERGROUND WATER TANK**

ITEM NO	DESCRIPTION	UNIT	QTY	RATE	AMOUNT
	<b><u>EXTERNAL WORKS</u></b>				
	<b><u>UNDERGROUND WATER TANK</u></b>				
	<b><u>SUBSTRUCTURE (ALL PROVISIONAL)</u></b>				
	<u>Excavations</u>				
A	Excavate over site to remove top soil average 200mm deep and cart away.	m <sup>2</sup>	625		
B	Excavate for pits commencing at reduced excavation level and not exceeding 1.50m deep.	m <sup>3</sup>	938		
C	Excavate for pits commencing at reduced excavation level and not exceeding 1.50-3m deep	m <sup>3</sup>	938		
D	Excavate for pits commencing at reduced excavation level and not exceeding 3-4.5m deep	m <sup>3</sup>	3,219		
E	Extra excavation for excavating in all types of rock and cart away.	m <sup>3</sup>	1,529		
F	Remove surplus excavated material from site.	m <sup>3</sup>	5,095		
	<u>Disposal</u>				
G	Allow for keeping the whole of the excavation free from all spring and running water by pumping or any other such means as may be necessary	Item	1		
H	Allow for planking and strutting to sides of already excavated surfaces and new excavated surfaces to keep excavations free from all fallen materials.	Item	1		
	<b><u>Fillings</u></b>				
J	Approved 300mm wide granular filling layers not exceeding 150mm thick	m <sup>2</sup>	625		
	<b><u>In situ concrete Class 15MPa: vibrated:</u></b>				
K	Floor slab	m <sup>2</sup>	625		
	Carried to Collection				

ITEM NO	DESCRIPTION	UNIT	QTY	RATE	AMOUNT
	<b>REINFORCED CONCRETE FRAME</b>				
	<u>In situ concrete class 30MPa: vibrated: reinforced</u>				
A	Beams	m <sup>2</sup>	15		
B	250mm RC wall	m <sup>2</sup>	173		
C	300mm RC wall	m <sup>2</sup>	701		
D	300mm bottom slab	m <sup>2</sup>	625		
E	200mm top slab	m <sup>2</sup>	625		
F	Extra over for boxing to form opening size 600 x 450mm through 200mm thick reinforced concrete slab; rebated edges	No	4		
G	Sump	No	4		
	<u>Ribbed reinforcement steel bars to KS 573:2014 : Grade 500 high tensile strength including bends, hooks, tying wire and distance blocks; to S.E's detail (Provisional)</u>				
H	Assorted reinforcement	kg	76,699		
	<u>Modular steel frame with steel plates covering formwork and/or marine board formwork: to</u>				
J	Sides of beams	m <sup>2</sup>	99		
K	RC wall	m <sup>2</sup>	1,749		
L	Soffits of suspended slab	m <sup>2</sup>	625		
M	Edge of floor slab 150 - 225mm high.	m	100		
N	Edge of floor slab 225 - 300mm high.	m	100		
	<u>Water Bar</u>				
P	250mm wide PVC water bar	m	124		
	Carried to Collection				
	<i>Underground Water Tank</i>				

ITEM NO	DESCRIPTION	UNIT	QTY	RATE	AMOUNT
	<b><u>FINISHES</u></b>				
	<b><u>WALL FINISHES</u></b>				
	<i>15mm cement and sand rendering on concrete surfaces finished with a wood float to:-</i>				
A	12mm Two coat external lime plaster on walls finished smooth with a steel trowel	m <sup>2</sup>	1,749		
	<b><u>Waterproofing</u></b>				
	<i>25mm thick 2 coats lime waterproofed plaster in "penetron Plus" as described:</i>				
B	300mm thick floor slab	m <sup>2</sup>	625		
C	Ditto to walls	m <sup>2</sup>	1,749		
	<b><u>Plastic manhole</u></b>				
E	Heavy duty plastic manhole cover and frame size 600x450mm wide with cover set in frame with grease	No	4		
F	Supply and fix approved 450mm, 10mm dia solid rungs wide stainless steel step ladder at 300mm centres fixed with SS bolts and nuts to structural details	No	4		
	Carried to Collection				
	<b><u>UNDERGROUND WATER TANK</u></b>				
	<b><u>COLLECTION</u></b>				
	Total brought forward from Page No.				
	Carried Forward to Summary				



# **MECHANICAL INSTALLATION WORKS**

BLOCK A

ITEM	DESCRIPTION	QTY.	UNIT	RATE (KES)	AMOUNT (KES)
<b>1.0</b>	<b>BLOCK A (G+9)</b> <b><u>Internal Plumbing Installations</u></b>				
	Supply, deliver install, Test and Commission: PP-R (Polypropylene Random Co-polymer) pipes PN 20 and fittings with polyfusion welded joints to <b>(KS ISO 15874 Part 1, 2, 3 &amp; 5)</b> of approved manufacturer. Rates must allow for all Metal/plastic threaded adaptors where required for the connection of sanitary fixtures, valves, sockets, sliding and fixed joints etc. as required in the running lengths of pipework. The pipes shall run in floors and wall chase. The pipes will be pressure tested before the plastering of wall commences and as per the manufacturers recommended testing pressures.				
(i)	<b><u>3 BR AHP</u></b>				
	<b>Pipe Works</b>				
A	32mm Ø PPR Pipe	2	LM		
B	Ditto 25mm Ø	20	LM		
	<b>Extra Over Pipe Work</b>				
	<b>Elbows/ Bends</b>				
C	32mm Ø Elbows/ Bends	2	No.		
D	Ditto 25mm Ø	14	No.		
	<b>Equal/Unequal Tees</b>				
E	32 x 32 x 32mm	1	No.		
F	25 x 25 x 25mm	7	No.		
	<b>Reducers</b>				
G	32 x 25mm reducer	1	No.		
	<b>Male/Female brass threaded adaptor</b>				
J	25 x 20mm male/female threaded adaptor	2	No.		
K	25 x 15mm ditto	4	LM		
L	25 x 15mm male threaded bend	14	LM		
<b>Total Carried to Next Page</b>					

BLOCK A

ITEM	DESCRIPTION	QTY.	UNIT	RATE (KES)	AMOUNT (KES)
	<b>Total from Previous Page</b>				
	<b>Isolating valves</b>				
M	25mm Ø Gate Valve as "Pegler" or Equivalent	1	No.		
	<b>Shut off Angle Valve</b>				
N	Brass plated 1/2" angle valve	7	No.		
	<b>Check Meter</b>				
O	25mm diameter water check meter	1	No.		
	<b>Testing and Commissioning</b>				
P	Allow for pressure testing of the Plumbing installation to the satisfaction of the Engineer including provision of necessary pipe plugs.	1	Item		
	<i>Sub Total for 1 Units</i>				
	<b>TOTAL FOR 1 No. 3BR AHP (Per Floor)</b>	1		x 1	
<b>Total Cost of Plumbing Installation for 3BR AHP per Floor</b>					

BLOCK A

ITEM	DESCRIPTION	QTY.	UNIT	RATE (KES)	AMOUNT (KES)
(ii)	<b>3 Room Social</b>				
	<b>Pipe Works</b>				
A	32mm Ø PPR Pipe	2	LM		
B	Ditto 25mm Ø	15	LM		
	<b>Extra Over Pipe Work</b>				
	<b>Elbows/ Bends</b>				
C	32mm Ø Elbows/ Bends	2	No.		
D	Ditto 25mm Ø	8	No.		
	<b>Equal/Unequal Tees</b>				
E	32 x 32 x 32mm	1	No.		
F	25 x 25 x 25mm	4	No.		
	<b>Reducers</b>				
G	32 x 25mm reducer	1	No.		
	<b>Male/Female brass threaded adaptor</b>				
J	25 x 20mm male/female threaded adaptor	2	No.		
K	25 x 15mm ditto	4	LM		
L	25 x 15mm male threaded bend	8	LM		
	<b>Isolating valves</b>				
M	25mm Ø Gate Valve as "Pegler" or Equivalent	1	No.		
	<b>Shut off Angle Valve</b>				
N	Brass plated 1/2" angle valve	4	No.		
	<b>Check Meter</b>				
O	25mm diameter water check meter	1	No.		
	<b>Testing and Commissioning</b>				
P	Allow for pressure testing of the Plumbing installation to the satisfaction of the Engineer including provision of necessary pipe plugs.	1	Item		
	<i>Sub Total for 1 Units</i>				
	<b>TOTAL FOR 1 No. 3Room Social (Per Floor)</b>	1		x 1	
<b>Total Cost of Plumbing Installation for 3Room Social per Floor</b>					

BLOCK A

ITEM	DESCRIPTION	QTY.	UNIT	RATE (KES)	AMOUNT (KES)
(iii)	<b>2 BR AHP</b>				
	<b>Pipe Works</b>				
A	32mm Ø PPR Pipe	2	LM		
B	Ditto 25mm Ø	15	LM		
	<b>Extra Over Pipe Work</b>				
	<b>Elbows/ Bends</b>				
C	32mm Ø Elbows/ Bends	2	No.		
D	Ditto 25mm Ø	8	No.		
	<b>Equal/Unequal Tees</b>				
E	32 x 32 x 32mm	1	No.		
F	25 x 25 x 25mm	4	No.		
	<b>Reducers</b>				
G	32 x 25mm reducer	1	No.		
	<b>Male/Female brass threaded adaptor</b>				
J	25 x 20mm male/female threaded adaptor	2	No.		
K	25 x 15mm ditto	4	LM		
L	25 x 15mm male threaded bend	8	LM		
	<b>Isolating valves</b>				
M	25mm Ø Gate Valve as "Pegler" or Equivalent	1	No.		
	<b>Shut off Angle Valve</b>				
N	Brass plated 1/2" angle valve	4	No.		
	<b>Check Meter</b>				
O	25mm diameter water check meter	1	No.		
	<b>Testing and Commissioning</b>				
P	Allow for pressure testing of the Plumbing installation to the satisfaction of the Engineer including provision of necessary pipe plugs.	1	Item		
	<i>Sub Total for 1 Units</i>				
	<b>TOTAL FOR 4 No. 2BR AHP (Per Floor)</b>	4		x 4	
<b>Total Cost of Plumbing Installation for 2BR AHP per Floor</b>					

BLOCK A

ITEM	DESCRIPTION	QTY.	UNIT	RATE (KES)	AMOUNT (KES)
(iv)	<b>2 Room Social</b>				
	<b>Pipe Works</b>				
A	32mm Ø PPR Pipe	2	LM		
B	Ditto 25mm Ø	15	LM		
	<b>Extra Over Pipe Work</b>				
	<b>Elbows/ Bends</b>				
C	32mm Ø Elbows/ Bends	2	No.		
D	Ditto 25mm Ø	8	No.		
	<b>Equal/Unequal Tees</b>				
E	32 x 32 x 32mm	1	No.		
F	25 x 25 x 25mm	4	No.		
	<b>Reducers</b>				
G	32 x 25mm reducer	1	No.		
	<b>Male/Female brass threaded adaptor</b>				
J	25 x 20mm male/female threaded adaptor	2	No.		
K	25 x 15mm ditto	4	LM		
L	25 x 15mm male threaded bend	8	LM		
	<b>Isolating valves</b>				
M	25mm Ø Gate Valve as "Pegler" or Equivalent	1	No.		
	<b>Shut off Angle Valve</b>				
N	Brass plated 1/2" angle valve	4	No.		
	<b>Check Meter</b>				
O	25mm diameter water check meter	1	No.		
	<b>Testing and Commissioning</b>				
P	Allow for pressure testing of the Plumbing installation to the satisfaction of the Engineer including provision of necessary pipe plugs.	1	Item		
	<i>Sub Total for 1 Units</i>				
	<b>TOTAL FOR 2 No. 2 Room Social (Per Floor)</b>	2		x 2	
<b>Total Cost of Plumbing Installation for 2Room Social per Floor</b>					

BLOCK A

ITEM	DESCRIPTION	QTY.	UNIT	RATE (KES)	AMOUNT (KES)
(v)	<b>1 Room Social</b>				
	<b>Pipe Works</b>				
A	32mm Ø PPR Pipe	2	LM		
B	Ditto 25mm Ø	15	LM		
	<b>Extra Over Pipe Work</b>				
	<b>Elbows/ Bends</b>				
C	32mm Ø Elbows/ Bends	2	No.		
D	Ditto 25mm Ø	8	No.		
	<b>Equal/Unequal Tees</b>				
E	32 x 32 x 32mm	1	No.		
F	25 x 25 x 25mm	4	No.		
	<b>Reducers</b>				
G	32 x 25mm reducer	1	No.		
	<b>Male/Female brass threaded adaptor</b>				
J	25 x 20mm male/female threaded adaptor	2	No.		
K	25 x 15mm ditto	4	LM		
L	25 x 15mm male threaded bend	8	LM		
	<b>Isolating valves</b>				
M	25mm Ø Gate Valve as "Pegler" or Equivalent	1	No.		
	<b>Shut off Angle Valve</b>				
N	Brass plated 1/2" angle valve	4	No.		
	<b>Check Meter</b>				
O	25mm diameter water check meter	1	No.		
	<b>Testing and Commissioning</b>				
P	Allow for pressure testing of the Plumbing installation to the satisfaction of the Engineer including provision of necessary pipe plugs.	1	Item		
	<b>Sub Total for 1 Units</b>				
	<b>TOTAL FOR 1 No. 1Room Social (Per Floor)</b>	1		x 1	
<b>Total Cost of Plumbing Installation for 1Room Social per Floor</b>					

BLOCK A

ITEM	DESCRIPTION	QTY.	UNIT	RATE (KES)	AMOUNT (KES)
(vi)	<u>Studio Apartment</u>				
	<b>Pipe Works</b>				
A	32mm Ø PPR Pipe	2	LM		
B	Ditto 25mm Ø	15	LM		
	<b>Extra Over Pipe Work</b>				
	<b>Elbows/ Bends</b>				
C	32mm Ø Elbows/ Bends	2	No.		
D	Ditto 25mm Ø	8	No.		
	<b>Equal/Unequal Tees</b>				
E	32 x 32 x 32mm	1	No.		
F	25 x 25 x 25mm	4	No.		
	<b>Reducers</b>				
G	32 x 25mm reducer	1	No.		
	<b>Male/Female brass threaded adaptor</b>				
J	25 x 20mm male/female threaded adaptor	2	No.		
K	25 x 15mm ditto	4	LM		
L	25 x 15mm male threaded bend	8	LM		
	<b>Isolating valves</b>				
M	25mm Ø Gate Valve as "Pegler" or Equivalent	1	No.		
	<b>Shut off Angle Valve</b>				
N	Brass plated 1/2" angle valve	4	No.		
	<b>Check Meter</b>				
O	25mm diameter water check meter	1	No.		
	<b>Testing and Commissioning</b>				
P	Allow for pressure testing of the Plumbing installation to the satisfaction of the Engineer including provision of necessary pipe plugs.	1	Item		
	<i>Sub Total for 1 Units</i>				
	<b>TOTAL FOR 2 No. Sudios (Per Floor)</b>	2		x 2	
<b>Total Cost of Plumbing Installation for 2Room Social per Floor</b>					



BLOCK A

ITEM	DESCRIPTION	QTY.	UNIT	RATE (KES)	AMOUNT (KES)
(vii)	<u>1 No. Extra Apartment on Ground Floor</u>				
	<b>Pipe Works</b>				
A	32mm Ø PPR Pipe	2	LM		
B	Ditto 25mm Ø	15	LM		
	<b>Extra Over Pipe Work</b>				
	<b>Elbows/ Bends</b>				
C	32mm Ø Elbows/ Bends	2	No.		
D	Ditto 25mm Ø	8	No.		
	<b>Equal/Unequal Tees</b>				
E	32 x 32 x 32mm	1	No.		
F	25 x 25 x 25mm	4	No.		
	<b>Reducers</b>				
G	32 x 25mm reducer	1	No.		
	<b>Male/Female brass threaded adaptor</b>				
J	25 x 20mm male/female threaded adaptor	2	No.		
K	25 x 15mm ditto	4	LM		
L	25 x 15mm male threaded bend	8	LM		
	<b>Isolating valves</b>				
M	25mm Ø Gate Valve as "Pegler" or Equivalent	1	No.		
	<b>Shut off Angle Valve</b>				
N	Brass plated 1/2" angle valve	4	No.		
	<b>Check Meter</b>				
O	25mm diameter water check meter	1	No.		
	<b>Testing and Commissioning</b>				
P	Allow for pressure testing of the Plumbing installation to the satisfaction of the Engineer including provision of necessary pipe plugs.	1	Item		
	<i>Sub Total for 1 Units</i>				
	<b>TOTAL FOR 1 No. Studio (Extra)</b>	1		x1	
<b>Total Cost of Plumbing Installation for the Extra Studio</b>					

BLOCK A

ITEM	DESCRIPTION	AMOUNT (KES)
	<b><u>Typical Floor Collection Page</u></b>	
1	Total Cost For Plumbing Installation for 3BR AHP	
2	Total Cost For Plumbing Installation for 3Room Social	
3	Total Cost For Plumbing Installation for 2BR AHP	
4	Total Cost For Plumbing Installation for 2Room Social	
5	Total Cost For Plumbing Installation for 1Room Social	
6	Total Cost For Plumbing Installation for Studio Apartment	
7	Total Plumbing Cost Per Floor	
8	<b>Total Plumbing Cost for G + 9 Levels ( Item 7 x 10 Floors)</b>	
9	<b>Add Total Cost of Extra Studio Apartment on Ground Floor</b>	
	<b>Total Cost (Item 8 +7) of Plumbing Carried to Summary Page</b>	-

BLOCK A

ITEM	DESCRIPTION	QTY.	UNIT	RATE (KES)	AMOUNT (KES)
2	<b>Risers and Roof Levels</b>				
	<b>Pipe Works</b>				
A	75mm Ø PPR pipe	50	LM		
B	Ditto 63mm Ø	50	LM		
B	Ditto 50mm Ø	50	LM		
C	Ditto 40mm Ø	40	LM		
	<b>Extra Over Pipe Work</b>				
	<b>Elbows/ Bends</b>				
D	75mm Ø Elbows/ Bends	12	No.		
E	Ditto 63mm Ø	25	No.		
F	Ditto 50mm Ø	8	No.		
G	Ditto 40mm Ø	16	No.		
H	Ditto 32mm Ø	16	No.		
I	Ditto 25mm Ø	8	No.		
	<b>Equal/Unequal Tees</b>				
J	63 x 63 x 63mm	10	No.		
K	40 x 40 x 40mm	8	No.		
L	40 x 40 x 32mm	16	No.		
M	32 x 32 x 32mm	4	No.		
N	32 x 32 x 25mm	4	No.		
O	25 x 25 x 25mm	12	No.		
	<b>Reducers</b>				
P	63 x 50mm reducer	6	No.		
Q	50 x 40mm reducer	6	No.		
R	40 x 32mm reducer	6	No.		
S	40 x 32mm reducer	6	No.		
T	32 x 25mm reducer	8	No.		
	<b>Male/Female brass threaded adaptor</b>				
U	40 x 32mm male/female threaded adaptor	5	No.		
V	32 x 25mm male/female threaded adaptor	7	No.		
<b>Total Carried to the Next Page</b>					

BLOCK A

ITEM	DESCRIPTION	QTY.	UNIT	RATE (KES)	AMOUNT (KES)
	<b>Total from Previous Page</b>				
	<b>Isolating valves</b>				
W	65mm Ø Gate Valve as "Pegler" or Equivalent	1	No.		
X	40mm Ø Ditto	1	No.		
	<b>Testing and Commissioning</b>				
Y	Allow for pressure testing of the Plumbing installation to the satisfaction of the Engineer including provision of necessary pipe plugs.	1	Item		
	<i>Sub Total for 1 Riser</i>				
	<b>TOTAL FOR 4 No. Risers</b>	4		x 4	
<b>Total Cost of Riser &amp; Roof Level Plumbing</b>					

BLOCK A

ITEM	DESCRIPTION	QTY.	UNIT	RATE (KES)	AMOUNT (KES)
3	<b>SANITARY FITTINGS AND ACCESSORIES INSTALL ONLY</b>				
A	<b>Water Closet (WC) Pan</b> Floor Standing Close Coupled WC Bowl complete with seat cover, flexible connection and cistern, WC connector relevant fittings & accessories <i>(Quote Install Only)</i>	121	No.		
B	<b>Wash Basin</b> Wall Hang Wash Basin 450x485x230m White Complete with bottle traps, flexible connection hoses and other accessories with cws only tap <i>(Quote Install Only)</i>	121	No.		
C	<b>Shower Fittings</b> Shower fitting c/w 15mm diameter chrome plated stop cork, Instant shower fitting and 1/2" Cobra wall mounted tap as Pegler or equal and equivalent <i>(Quote Install Only)</i>	121	No.		
D	<b>Bathroom Accessories</b> Medium Washroom bathroom set Consisitng of Toilet roll holder, soap dish holder, and Coat Hooke <i>(Quote Install Only)</i>	121	Set		
E	<b>Kitchen Sink</b> Stainless steel kitchen sink single drain, single bowl complete overflow and 40mm diameter plastic tubular p-trap PVC Bottle Trap and waste 1.5in x 40, Long Neck Wall type Bib Tap <i>(Quote Install Only)</i>	111	No.		
<b>Total Cost of Sanitary Fittings &amp; Accessories</b>					

BLOCK A

ITEM	DESCRIPTION	QTY.	UNIT	RATE (KES)	AMOUNT (KES)
	<b>FIRE PROTECTION</b>				
	<b>Hose Reel and Associated Pipework</b>				
A	Supply and Install automatic 30 meters long, 25 mm diameter hosereel and nozzle installed to KS 2003:2006	10	No.		
	<b>Associated Pipework</b>				
	GI Class 'B' tubing to KS06-259 with screwed and socketed joints to KS ISO 7-1:1994 including all range piping, fittings, hanagers, supports, brackets, and supports				
B	50mm diameter	65	LM		
C	25mm ditto	13	LM		
	<b>Extra Over Piping For Fittings:-</b>				
	<b>Elbows/Various Bends</b>				
D	50mm bend/elbow	7	No.		
E	25mm ditto	20	No.		
	<b>Equal/Unequal tees</b>				
F	50 x 50 x 50mm tee	10	No.		
G	50 x 50 x 25mm ditto	19	No.		
	<b>Reducers</b>				
H	50 x 25mm reducer	10	No.		
	<b>Unions</b>				
I	50mm diameter union	2	No.		
J	25mm ditto	20	No.		
	<b>Valves</b>				
K	25mm diameter quarter Turn hose reel isolation valve to be as PEGLER or approved equivalent.	20	No.		
	<b>Painting</b>				
L	Allow for Wire brushing , cleaning and painting of the complete fire fighting pipework installation with one coat of red oxide primer, undercoat, and gloss coat to specifications	1	Item		
<b>Total Cost Carried For hose reel and associated pipework Installations</b>					

BLOCK A

ITEM	DESCRIPTION	QTY.	UNIT	RATE (KES)	AMOUNT (KES)
	<p><b><u>Portable Fire Protection Equipment + Hose Reel Pump</u></b>  <b>Supply, deliver, install, test and commission</b>                      portable fire protection equipment with initial fill complete with all the necessary mounting accessories.</p> <p><b>A</b> 9 litres, carbon dioxide gas extinguisher</p> <p><b>B</b> 4.5kg ABC dry powder extinguisher</p> <p><b>C</b> Supply and fix signs indicating the words "FIRE POINT" in 80mm high letters</p> <p><b>Testing and Commissioning</b>                      Allow for testing and commissioning of the fire pump installation to the satisfaction of the Engineer.</p> <p><b>D</b></p>	<p></p> <p>10</p> <p>10</p> <p>10</p> <p></p> <p>1</p>	<p></p> <p>No.</p> <p>No.</p> <p>No.</p> <p></p> <p>Item</p>	<p></p> <p></p> <p></p> <p></p> <p></p>	<p></p> <p></p> <p></p> <p></p> <p></p>
<b>Total Cost For Portable fire Extinguishers + Hose Reel Pump Installation</b>					

## BLOCK A

ITEM	DESCRIPTION	UNIT	QTY	RATE	AMOUNT
	<b><u>DRY RISER</u></b> Supply , deliver and install <b>Galvernised Iron (GI) Pipe B.S. 1387 and KS 06-259</b> socketed joints to BS21 and Groove fittings including fixing and jointing. Tenderers must allow in their pipework prices for Galvanised Support Brackets after every 1.5 Mts for the Horizontal runs and every 2mts for the vertical runs c/w EPDM Rubber insulation material, Clamping screw, Noise reduction of 18.5dBA, Threaded Rod, Bolts & all the couplings, connectors, joints etc.required in the running length of pipework and also where necessary, for pipe fixing clips, holderbats plugged and screwed, brackets and pipe sleeves through structural				
1	100mm diameter GI	LM	48		
	<b><u>Extra over GI Pipe tubing for the following:</u></b>				
	<b><u>Bends</u></b>				
2	100mm diameter bend	No.	6		
	<b><u>Tees</u></b>				
3	100mm ditto	No.	8		
	<b><u>Reducing Bushes</u></b>				
4	100x65mm reducing bush	No.	10		
	<b><u>Couplers</u></b>				
5	100mm diameter union	No.	9		
	<b><u>Flanges</u></b>				
6	65mm dia flanges(pair, including bolts, nuts and gasket)	No.	10		
	<b><u>Landing Valve</u></b>				
7	65mm diameter landing valve as Merry - Weather "Equery" constant pressure outlet with flanged inlet and 1No. 65mm dia female instantaneous outlet with blank cap and chain.	No.	10		
	<b><u>Fire Hose</u></b>				
8	65mmdia x30m long canvas hose as specified	No.	10		
9	Hose cradle for above canvas hose	No.	10		
10	65mm dia branch pipe complete with nozzle/sp	No.	10		
	<b>TOTAL TO NEXT PAGE</b>				



BLOCK A

ITEM	DESCRIPTION	UNIT	QTY	RATE	AMOUNT
	<i>Balance brought forward</i>				
	<b><u>Gate Valves</u></b>				
11	100mm dia approved high pressure screw-down full way non-rising stem solid wedge disc gate valve to BS 5154 PN 16 for Series B Rating with wheel head and joints to steel tubing.	No.	1		
12	100mm 2-way horizontal mounted pumping in breeching inlet to BS 5041 Part 3 and horizontal inlet box with door fitted with Georgian wired glass panel to BS5041 Part 5. Inclusive of Breeching inlet cabinet as specified complete with access break glass and painted	Item	1		
13	25mm dia Air Relief Valve as specified	No.	1		
14	Wire brush , clean, and paint complete installation with one coat of red oxide primer, undercoat, and gloss coat to Architects colour including banding and colour coding to British Standards	Sum	1		
	<b><u>Pressure testing and Painting</u></b>				
15	Allow for pressure testing of the entire Dry riser installation and obtain relevant test certificates endorsed by the Engineer or his representative.	Sum	1		
	Sub Total For 1No. Block				
<b>TOTAL COST FOR DRY RISER TO MAIN SUMMARY PAGE</b>					

BLOCK A

ITEM	DESCRIPTION	QTY.	UNIT	RATE (KES)	AMOUNT (KES)
	<b><u>Foul Drainage (Ground Floor)</u></b>				
	Supply, deliver and install the following in <b>uPVC (Unplasticized Polyvinyl chloride)</b> to <b>(KS ISO 1452 Part 1, 2, 3, 4 &amp; 5)</b> Heavy gauge soil and waste system. Allow for all the various sizes of adaptor, connectors, sockets, holderbats, clips etc not measured but required for the satisfactory functioning of the system.				
	<b>Piping</b>				
A	32mm diameter heavy duty grey uPVC pipe	60	LM		
B	40mm ditto	60	LM		
C	50mm ditto	120	LM		
D	75mm ditto	80	LM		
E	100mm ditto	80	LM		
F	100mm diameter heavy duty golden brown	155	LM		
G	150mm diameter heavy duty golden brown	300	LM		
	<b>Extra over uPVC Pipeworks</b>				
H	32mm sweep bend	15	No.		
I	40mm sweep bend	60	No.		
J	50mm sweep bend	15	No.		
K	75mm sweep bend	8	No.		
L	100mm sweep bend	22	No.		
M	150mm sweep bend	16	No.		
N	40mm 450 bend	22	No.		
O	50mm 450 bend	15	No.		
P	40mm sweep tee	25	No.		
Q	40 x 32mm reducer	15	No.		
R	75 x 40mm ditto	15	No.		
S	150 x 40mm ditto	8	No.		
T	40mm access plug	22	No.		
U	150MM vent cowl	15	No.		
	<b>Total Carried to Next Page</b>				

BLOCK A

ITEM	DESCRIPTION	QTY.	UNIT	RATE (KES)	AMOUNT (KES)
	<b>Total From Previous Page</b>				
V	100 x 50mm floor trap set complete with plastic grating	17	No.		
AA	<b>Gulley Trap</b> Gully trap comprising of 100mm diameter golden brown uPVC gully piece, 100mm diameter uPVC trap spigot outlet with screws and washers, and 300 x 300mm masonry gully trap chamber with mild steel plate and a heavy	25	No.		
BB	<b>Manholes</b> Construct manhole/ inspection chamber size 450 x 600 x 750mm deep internally in 200mm stone walls, 150mm concrete bed, water proof plaster, forming drain channels, medium duty cover frame in cast iron with recessed cover with concrete infill and all necessary formwork, excavation and soil disposal.	32	No.		
CC	<b>Excavations</b> Excavate trench for pipe not exceeding 100mm diameter and not exceeding 1.5m deep (average 600mm deep) and make good as before.	120	LM		
DD	Allow for hydrostatic pressure testing of drainage installation including provision of pipe plugs and other required fittings.	1	Item		
<b>Total Cost For Ground Floor Foul Drainage Installation</b>					

BLOCK A

ITEM	DESCRIPTION	QTY.	UNIT	RATE (KES)	AMOUNT (KES)
	<b><u>Foul Drainage (1St Floor to 10th Floor)</u></b>				
	Supply, deliver and install the following in <b>uPVC (Unplasticized Polyvinyl chloride)</b> to <b>(KS ISO 1452 Part 1, 2, 3, 4 &amp; 5)</b> Heavy gauge soil and waste system. Allow for all the various sizes of adaptor, connectors, sockets, holderbats, clips etc not measured but required for the satisfactory functioning of the system.				
	<b>Piping</b>				
A	32mm diameter heavy duty grey uPVC pipe	20	LM		
B	40mm ditto	70	LM		
C	50mm ditto	40	LM		
D	100mm ditto	40	LM		
E	150mm ditto	120	LM		
	<b>Extra over uPVC Pipings</b>				
F	32mm sweep bend	15	No.		
G	40mm sweep bend	82	No.		
H	50mm sweep bend	15	No.		
I	40mm 450sweep bend	25	No.		
J	50mm 450sweep bend	15	No.		
K	50mm y-connector	8	No.		
L	50mm sweep tee	4	No.		
M	40mm sweep tee	32	No.		
N	40 x 32mm reducer	14	No.		
O	150 x 40mm reducer	8	No.		
P	150 x 50mm reducer	8	No.		
Q	150 x 100mm reducer	22	No.		
R	40mm access plug	25	No.		
S	100mm access plug	15	No.		
T	100mm single branch	2	No.		
U	150mm single branch	17	No.		
<b>Total Carried to Next Page</b>					-

BLOCK A

ITEM	DESCRIPTION	QTY.	UNIT	RATE (KES)	AMOUNT (KES)
	<b>Total From Previous Page</b>				
X	100 x 50mm floor trap set complete with polycarbonate flush grating	17	No.		
Y	Allow for hydrostatic pressure testing of drainage installation including provision of pipe plugs and other required fittings.	1	Item		
	<i>Sub Total for 1 Floor</i>				
	<b>TOTAL FOR 9 Floors</b>	9		x 9	
<b>Total Cost For 1st to 10th floor Foul Drainage Installation</b>					

BLOCK A

ITEM	DESCRIPTION	QTY.	UNIT	RATE (KES)	AMOUNT (KES)
	<b>Rain Water Drainage</b>				
	Supply, deliver and install UPVC (Unplasticized Polyvinyl chloride) to (KS ISO 1452 Part 1, 2, 3, 4 & 5) rainwater pipework. Allow for all flanges, couplings, nipples, connector joints, fixing clips holder bats etc as required in running length of pipework but not measured.				
	<b>Piping</b>				
A	100mm ditto	400	LM		
	Extra over piping for fittings:-				
B	100mm ditto	16	No.		
C	100mm sweep bend	2	No.		
D	100mm single branch	13	No.		
E	100mm double branch	7	No.		
F	100mm flat roof rain water outlets	10	No.		
	<b>Testing and Commissioning</b>				
	Allow for testing and commissioning of the rain water drainage installation to the satisfaction of the engineer.				
G		1	Item		
<b>Total Cost For Rain Water Drainage Installation</b>					

BLOCK A

ITEM	DESCRIPTION	AMOUNT (KES)
<u>SUMMARY PAGE</u>		
1.0	Total Cost for Internal Plumbing	
2.0	Total Cost for Roof + Riser	
3.0	Total Cost for Sanitary Fittings Install Only	
4.0	Total Cost Carried For hose reel and associated pipework Installations	
5.0	Total Cost For Portable fire Extinguishers + Hose Reel Pump Installation	
6.0	Total Cost For Dry Riser Installation	
7.0	Total Cost For Ground Floor Foul Drainage Installation	
8.0	Total Cost For 1st to 10th floor Foul Drainage Installation	
9.0	Total Cost For Rain Water Drainage Installation	
<b>Total carried to Mechanical Works Main Summary Page</b>		

BLOCK B

ITEM	DESCRIPTION	QTY.	UNIT	RATE (KES)	AMOUNT (KES)
	<b>BLOCK B G+9</b>				
<b>1.0</b>	<b><u>Internal Plumbing Installations</u></b>				
	Supply, deliver install, Test and Commission: PP-R (Polypropylene Random Co-polymer) pipes PN 20 and fittings with polyfusion welded joints to <b>(KS ISO 15874 Part 1, 2, 3 &amp; 5)</b> of approved manufacturer. Rates must allow for all Metal/plastic threaded adaptors where required for the connection of sanitary fixtures, valves, sockets, sliding and fixed joints etc. as required in the running lengths of pipework. The pipes shall run in floors and wall chase. The pipes will be pressure tested before the plastering of wall commences and as per the manufacturers recommended testing pressures.				
(i)	<b><u>3 BR AHP</u></b>				
	<b>Pipe Works</b>				
A	32mm Ø PPR Pipe	2	LM		
B	Ditto 25mm Ø	20	LM		
	<b>Extra Over Pipe Work</b>				
	<b>Elbows/ Bends</b>				
C	32mm Ø Elbows/ Bends	2	No.		
D	Ditto 25mm Ø	14	No.		
	<b>Equal/Unequal Tees</b>				
E	32 x 32 x 32mm	1	No.		
F	25 x 25 x 25mm	7	No.		
	<b>Reducers</b>				
G	32 x 25mm reducer	1	No.		
	<b>Male/Female brass threaded adaptor</b>				
J	25 x 20mm male/female threaded adaptor	2	No.		
K	25 x 15mm ditto	4	LM		
L	25 x 15mm male threaded bend	14	LM		
<b>Total Carried to Next Page</b>					



BLOCK B

ITEM	DESCRIPTION	QTY.	UNIT	RATE (KES)	AMOUNT (KES)
	<b>Total from Previous Page</b>				
	<b>Isolating valves</b>				
M	25mm Ø Gate Valve as "Pegler" or Equivalent	1	No.		
	<b>Shut off Angle Valve</b>				
N	Brass plated 1/2" angle valve	7	No.		
	<b>Check Meter</b>				
O	25mm diameter water check meter	1	No.		
	<b>Testing and Commissioning</b>				
P	Allow for pressure testing of the Plumbing installation to the satisfaction of the Engineer including provision of necessary pipe plugs.	1	Item		
	<i>Sub Total for 1 Units</i>				
	<b>TOTAL FOR 1 No. 3BR AHP (Per Floor)</b>	1		x 1	
<b>Total Cost of Plumbing Installation for 3BR AHP per Floor</b>					

BLOCK B

ITEM	DESCRIPTION	QTY.	UNIT	RATE (KES)	AMOUNT (KES)
(ii)	<b>3 BR Market</b>				
	<b>Pipe Works</b>				
A	32mm Ø PPR Pipe	2	LM		
B	Ditto 25mm Ø	20	LM		
	<b>Extra Over Pipe Work</b>				
	<b>Elbows/ Bends</b>				
C	32mm Ø Elbows/ Bends	2	No.		
D	Ditto 25mm Ø	14	No.		
	<b>Equal/Unequal Tees</b>				
E	32 x 32 x 32mm	1	No.		
F	25 x 25 x 25mm	7	No.		
	<b>Reducers</b>				
G	32 x 25mm reducer	1	No.		
	<b>Male/Female brass threaded adaptor</b>				
J	25 x 20mm male/female threaded adaptor	2	No.		
K	25 x 15mm ditto	4	LM		
L	25 x 15mm male threaded bend	14	LM		
	<b>Isolating valves</b>				
M	25mm Ø Gate Valve as "Pegler" or Equivalent	1	No.		
	<b>Shut off Angle Valve</b>				
N	Brass plated 1/2" angle valve	7	No.		
	<b>Check Meter</b>				
O	25mm diameter water check meter	1	No.		
	<b>Testing and Commissioning</b>				
P	Allow for pressure testing of the Plumbing installation to the satisfaction of the Engineer including provision of necessary pipe plugs.	1	Item		
	<i>Sub Total for 1 Units</i>				
	<b>TOTAL FOR 3 No. 3BR Market (Per Floor)</b>	3		x 3	
<b>Total Cost of Plumbing Installation for 3BR Market per Floor</b>					

BLOCK B

ITEM	DESCRIPTION	QTY.	UNIT	RATE (KES)	AMOUNT (KES)
(iii)	<b>2 BR AHP</b>				
	<b>Pipe Works</b>				
A	32mm Ø PPR Pipe	2	LM		
B	Ditto 25mm Ø	15	LM		
	<b>Extra Over Pipe Work</b>				
	<b>Elbows/ Bends</b>				
C	32mm Ø Elbows/ Bends	2	No.		
D	Ditto 25mm Ø	8	No.		
	<b>Equal/Unequal Tees</b>				
E	32 x 32 x 32mm	1	No.		
F	25 x 25 x 25mm	4	No.		
	<b>Reducers</b>				
G	32 x 25mm reducer	1	No.		
	<b>Male/Female brass threaded adaptor</b>				
J	25 x 20mm male/female threaded adaptor	2	No.		
K	25 x 15mm ditto	4	LM		
L	25 x 15mm male threaded bend	8	LM		
	<b>Isolating valves</b>				
M	25mm Ø Gate Valve as "Pegler" or Equivalent	1	No.		
	<b>Shut off Angle Valve</b>				
N	Brass plated 1/2" angle valve	4	No.		
	<b>Check Meter</b>				
O	25mm diameter water check meter	1	No.		
	<b>Testing and Commissioning</b>				
P	Allow for pressure testing of the Plumbing installation to the satisfaction of the Engineer including provision of necessary pipe plugs.	1	Item		
	<i>Sub Total for 1 Units</i>				
	<b>TOTAL FOR 1 No. 2BR AHP (Per Floor)</b>	1		x 1	
<b>Total Cost of Plumbing Installation for 2BR AHP per Floor</b>					

BLOCK B

ITEM	DESCRIPTION	QTY.	UNIT	RATE (KES)	AMOUNT (KES)
(iv)	<b>2 BR Market</b>				
	<b>Pipe Works</b>				
A	32mm Ø PPR Pipe	2	LM		
B	Ditto 25mm Ø	20	LM		
	<b>Extra Over Pipe Work</b>				
	<b>Elbows/ Bends</b>				
C	32mm Ø Elbows/ Bends	2	No.		
D	Ditto 25mm Ø	14	No.		
	<b>Equal/Unequal Tees</b>				
E	32 x 32 x 32mm	1	No.		
F	25 x 25 x 25mm	7	No.		
	<b>Reducers</b>				
G	32 x 25mm reducer	1	No.		
	<b>Male/Female brass threaded adaptor</b>				
J	25 x 20mm male/female threaded adaptor	2	No.		
K	25 x 15mm ditto	4	LM		
L	25 x 15mm male threaded bend	14	LM		
	<b>Isolating valves</b>				
M	25mm Ø Gate Valve as "Pegler" or Equivalent	1	No.		
	<b>Shut off Angle Valve</b>				
N	Brass plated 1/2" angle valve	7	No.		
	<b>Check Meter</b>				
O	25mm diameter water check meter	1	No.		
	<b>Testing and Commissioning</b>				
P	Allow for pressure testing of the Plumbing installation to the satisfaction of the Engineer including provision of necessary pipe plugs.	1	Item		
	<i>Sub Total for 1 Units</i>				
	<b>TOTAL FOR 3 No. 3BR Market (Per Floor)</b>	3		x 3	
<b>Total Cost of Plumbing Installation for 3BR Market per Floor</b>					



## BLOCK B

ITEM	DESCRIPTION	QTY.	UNIT	RATE (KES)	AMOUNT (KES)
<b>2</b>	<b>Risers and Roof Levels</b>				
	<b>Pipe Works</b>				
A	75mm Ø PPR pipe	50	LM		
B	Ditto 63mm Ø	50	LM		
B	Ditto 50mm Ø	50	LM		
C	Ditto 40mm Ø	40	LM		
	<b>Extra Over Pipe Work</b>				
	<b>Elbows/ Bends</b>				
D	75mm Ø Elbows/ Bends	12	No.		
E	Ditto 63mm Ø	25	No.		
F	Ditto 50mm Ø	8	No.		
G	Ditto 40mm Ø	16	No.		
H	Ditto 32mm Ø	16	No.		
I	Ditto 25mm Ø	8	No.		
	<b>Equal/Unequal Tees</b>				
J	63 x 63 x 63mm	10	No.		
K	40 x 40 x 40mm	8	No.		
L	40 x 40 x 32mm	16	No.		
M	32 x 32 x 32mm	4	No.		
N	32 x 32 x 25mm	4	No.		
O	25 x 25 x 25mm	12	No.		
	<b>Reducers</b>				
P	63 x 50mm reducer	6	No.		
Q	50 x 40mm reducer	6	No.		
R	40 x 32mm reducer	6	No.		
S	40 x 32mm reducer	6	No.		
T	32 x 25mm reducer	8	No.		
	<b>Male/Female brass threaded adaptor</b>				
U	40 x 32mm male/female threaded adaptor	5	No.		
V	32 x 25mm male/female threaded adaptor	7	No.		
<b>Total Carried to the Next Page</b>					

BLOCK B

ITEM	DESCRIPTION	QTY.	UNIT	RATE (KES)	AMOUNT (KES)
	<b>Total from Previous Page</b>				
	<b>Isolating valves</b>				
W	65mm Ø Gate Valve as "Pegler" or Equivalent	1	No.		
X	40mm Ø Ditto	1	No.		
	<b>Testing and Commissioning</b>				
Y	Allow for pressure testing of the Plumbing installation to the satisfaction of the Engineer including provision of necessary pipe plugs.	1	Item		
	<i>Sub Total for 1 Riser</i>				
	<b>TOTAL FOR 4 No. Risers</b>	4		x 4	
<b>Total Cost of Riser &amp; Roof Level Plumbing</b>					-

BLOCK B

ITEM	DESCRIPTION	QTY.	UNIT	RATE (KES)	AMOUNT (KES)
3	<b>SANITARY FITTINGS AND ACCESSORIES INSTALL ONLY</b>				
A	<b>Water Closet (WC) Pan</b> Floor Standing Close Coupled WC Bowl complete with seat cover, flexible connection and cistern, WC connector relevant fittings & accessories <i>(Quote Install Only)</i>	15	No.		
B	<b>Wash Basin</b> Wall Hang Wash Basin 450x485x230m White Complete with bottle traps, flexible connection hoses and other accessories with cws only tap <i>(Quote Install Only)</i>	15	No.		
C	<b>Shower Fittings</b> Shower fitting c/w 15mm diameter chrome plated stop cork, Instant shower fitting and 1/2" Cobra wall mounted tap as Pegler or equal and equivalent <i>(Quote Install Only)</i>	15	No.		
E	<b>Bathroom Accessories</b> Medium Washroom bathroom set Consisitng of Toilet roll holder, soap dish holder, and Coat Hooke <i>(Quote Install Only)</i>	15	Set		
F	<b>Kitchen Sink</b> Stainless steel kitchen sink single drain, single bowl complete overflow and 40mm diameter plastic tubular p-trap PVC Bottle Trap and waste 1.5in x 40, Long Neck Wall type Bib Tap <i>(Quote Install Only)</i>	8	No.		
	<i>Sub Total for 1 Floor</i>				
	<b>TOTAL FOR 10 Floors</b>	10		x 10	
<b>Total Cost of Sanitary Fittings &amp; Accessories</b>					



BLOCK B

ITEM	DESCRIPTION	QTY.	UNIT	RATE (KES)	AMOUNT (KES)
	<b>FIRE PROTECTION</b>				
	<b>Hose Reel and Associated Pipework</b>				
A	Supply and Install automatic 30 meters long, 25 mm diameter hosereel and nozzle installed to <b>KS 2003:2006</b>	10	No.		
	<b>Associated Pipework</b>				
	GI Class 'B' tubing to KS06-259 with screwed and socketed joints to KS ISO 7-1:1994 including all range piping, fittings, hanagers, supports, brackets, and supports				
B	50mm diameter	65	LM		
C	25mm ditto	13	LM		
	<b>Extra Over Piping For Fittings:-</b>				
	<b>Elbows/Various Bends</b>				
D	50mm bend/elbow	7	No.		
E	25mm ditto	20	No.		
	<b>Equal/Unequal tees</b>				
F	50 x 50 x 50mm tee	10	No.		
G	50 x 50 x 25mm ditto	19	No.		
	<b>Reducers</b>				
H	50 x 25mm reducer	10	No.		
	<b>Unions</b>				
I	50mm diameter union	2	No.		
J	25mm ditto	20	No.		
	<b>Valves</b>				
K	25mm diameter quarter Turn hose reel isolation valve to be as PEGLER or approved equivalent.	20	No.		
	<b>Painting</b>				
L	Allow for Wire brushing , cleaning and painting of the complete fire fighting pipework installation with one coat of red oxide primer, undercoat, and gloss coat to specifications	1	Item		
<b>Total Cost Carried For hose reel and associated pipework Installations</b>					

BLOCK B

ITEM	DESCRIPTION	QTY.	UNIT	RATE (KES)	AMOUNT (KES)
	<p><b><u>Portable Fire Protection Equipment + Hose</u></b>  <b>Reel Pump</b>  <b>Supply, deliver, install, test and commission</b>                      portable fire protection equipment with initial fill complete with all the necessary mounting accessories.</p> <p><b>A</b> 9 litres, carbon dioxide gas extinguisher</p> <p><b>B</b> 4.5kg ABC dry powder extinguisher</p> <p><b>C</b> Supply and fix signs indicating the words "FIRE POINT" in 80mm high letters</p> <p><b>Testing and Commissioning</b>                      Allow for testing and commissioning of the fire pump installation to the satisfaction of the Engineer.</p> <p><b>D</b></p>	<p></p> <p>10</p> <p>10</p> <p>10</p> <p></p> <p>1</p>	<p></p> <p>No.</p> <p>No.</p> <p>No.</p> <p></p> <p>Item</p>	<p></p> <p></p> <p></p> <p></p> <p></p>	<p></p> <p></p> <p></p> <p></p> <p></p>
<b>Total Cost For Portable fire Extinguishers + Hose Reel Pump Installation</b>					

BLOCK B

ITEM	DESCRIPTION	UNIT	QTY	RATE	AMOUNT
	<b><u>DRY RISER</u></b> Supply , deliver and install <b>Galvernised Iron (GI) Pipe B.S. 1387 and KS 06-259</b> socketed joints to BS21 and Groove fittings including fixing and jointing. Tenderers must allow in their pipework prices for Galvanised Support Brackets after every 1.5 Mts for the Horizontal runs and every 2mts for the vertical runs c/w EPDM Rubber insulation material, Clamping screw, Noise reduction of 18.5dBA, Threaded Rod, Bolts & all the couplings, connectors, joints etc.required in the running length of pipework and also where necessary, for pipe fixing clips, holderbats plugged and screwed, brackets and pipe sleeves through structural				
1	100mm diameter GI	LM	48		
	<b><u>Extra over GI Pipe tubing for the following:</u></b>				
	<b><u>Bends</u></b>				
2	100mm diameter bend	No.	6		
	<b><u>Tees</u></b>				
3	100mm ditto	No.	8		
	<b><u>Reducing Bushes</u></b>				
4	100x65mm reducing bush	No.	10		
	<b><u>Couplers</u></b>				
5	100mm diameter union	No.	9		
	<b><u>Flanges</u></b>				
6	65mm dia flanges(pair, including bolts, nuts and gasket)	No.	10		
	<b><u>Landing Valve</u></b>				
7	65mm diameter landing valve as Merry - Weather "Equery" constant pressure outlet with flanged inlet and 1No. 65mm dia female instantaneous outlet with blank cap and chain.	No.	10		
	<b><u>Fire Hose</u></b>				
8	65mmdia x30m long canvas hose as specified	No.	10		
9	Hose cradle for above canvas hose	No.	10		
10	65mm dia branch pipe complete with nozzle/sp	No.	10		
	<b>TOTAL TO NEXT PAGE</b>				

BLOCK B

ITEM	DESCRIPTION	UNIT	QTY	RATE	AMOUNT
	<i>Balance brought forward</i>				
	<b><u>Gate Valves</u></b>				
11	100mm dia approved high pressure screw-down full way non-rising stem solid wedge disc gate valve to BS 5154 PN 16 for Series B Rating with wheel head and joints to steel tubing.	No.	1		
12	100mm 2-way horizontal mounted pumping in breeching inlet to BS 5041 Part 3 and horizontal inlet box with door fitted with Georgian wired glass panel to BS5041 Part 5. Inclusive of Breeching inlet cabinet as specified complete with access break glass and painted	Item	1		
13	25mm dia Air Relief Valve as specified	No.	1		
14	Wire brush , clean, and paint complete installation with one coat of red oxide primer, undercoat, and gloss coat to Architects colour including banding and colour coding to British Standards	Sum	1		
	<b><u>Pressure testing and Painting</u></b>				
15	Allow for pressure testing of the entire Dry riser installation and obtain relevant test certificates endorsed by the Engineer or his representative.	Sum	1		
	Sub Total For 1No. Block				
<b>TOTAL COST FOR DRY RISER TO MAIN SUMMARY PAGE</b>					

BLOCK B

ITEM	DESCRIPTION	QTY.	UNIT	RATE (KES)	AMOUNT (KES)
	<b><u>Foul Drainage (Ground Floor)</u></b>				
	Supply, deliver and install the following in uPVC (Unplasticized Polyvinyl chloride) to (KS ISO 1452 Part 1, 2, 3, 4 & 5) Heavy gauge soil and waste system. Allow for all the various sizes of adaptor, connectors, sockets, holderbats, clips etc not measured but required for the satisfactory functioning of the system.				
	<b>Piping</b>				
A	32mm diameter heavy duty grey uPVC pipe	24	LM		
B	40mm ditto	36	LM		
C	50mm ditto	72	LM		
D	75mm ditto	90	LM		
E	100mm ditto	90	LM		
F	100mm diameter heavy duty pipe	120	LM		
G	150mm diameter heavy duty pipe	300	LM		
	<b>Extra over uPVC Pipeworks</b>				
H	32mm sweep bend	13	No.		
I	40mm sweep bend	60	No.		
J	50mm sweep bend	13	No.		
K	75mm sweep bend	6	No.		
L	100mm sweep bend	15	No.		
M	150mm sweep bend	6	No.		
N	40mm 45° bend	20	No.		
O	50mm Ditto	15	No.		
P	75mm Ditto	65	No.		
Q	150mm Ditto	60	No.		
R	40mm sweep tee	20	No.		
S	50mm sweep tee	18	No.		
T	75mm ditto	15	No.		
U	40 x 32mm reducer	60	No.		
V	75 x 40mm ditto	20	No.		
W	150 x 40mm reducer	6	No.		
X	40mm access plug	20	No.		
Y	50mm access plug	13	No.		
Z	75mm access plug	13	No.		
	<b>Total Carried to Next Page</b>				

BLOCK B

ITEM	DESCRIPTION	QTY.	UNIT	RATE (KES)	AMOUNT (KES)
	<b>Total From Previous Page</b>				
AA	100 x 50mm floor trap set complete with polycarbonate flush grating	25	No.		
BB	150MM vent cowl	15	No.		
	<b>Gulley Trap</b>				
CC	Gully trap comprising of 100mm diameter golden brown uPVC gully piece, 100mm diameter uPVC trap spigot outlet with screws and washers, and 300 x 300mm masonry gully trap chamber with mild steel plate and a heavy	25	No.		
	<b>Manholes</b>				
DD	Construct manhole/ inspection chamber size 450 x 600 x 750mm deep internally in 200mm stone walls, 150mm concrete bed, water proof plaster, forming drain channels, medium duty cover frame in cast iron with recessed cover with concrete infill and all necessary formwork, excavation and soil disposal.	32	No.		
	<b>Excavations</b>				
EE	Excavate trench for pipe not exceeding 100mm diameter and not exceeding 1.5m deep (average 600mm deep) and make good as before.	120	LM		
II	Allow for hydrostatic pressure testing of drainage installation including provision of pipe plugs and other required fittings.	1	Item		
<b>Total Cost For Ground Floor Foul Drainage Installation</b>					

BLOCK B

ITEM	DESCRIPTION	QTY.	UNIT	RATE (KES)	AMOUNT (KES)
	<b>Foul Drainage (1St Floor to 10th Floor)</b>				
	Supply, deliver and install the following in <b>uPVC (Unplasticized Polyvinyl chloride)</b> to <b>(KS ISO 1452 Part 1, 2, 3, 4 &amp; 5)</b> Heavy gauge soil and waste system. Allow for all the various sizes of adaptor, connectors, sockets, holderbats, clips etc not measured but required for the satisfactory functioning of the system.				
	<b>Piping</b>				
A	32mm diameter heavy duty grey uPVC pipe	18	LM		
B	40mm ditto	60	LM		
C	50mm ditto	36	LM		
D	100mm ditto	30	LM		
E	150mm ditto	120	LM		
	<b>Extra over uPVC Pippings</b>				
F	32mm sweep bend	13	No.		
G	40mm sweep bend	80	No.		
H	50mm sweep bend	13	No.		
I	40mm 450sweep bend	24	No.		
J	50mm 450sweep bend	13	No.		
K	50mm y-connector	6	No.		
L	50mm sweep tee	2	No.		
M	40mm sweep tee	30	No.		
N	40 x 32mm reducer	13	No.		
O	150 x 40mm reducer	6	No.		
P	150 x 50mm reducer	6	No.		
Q	150 x 100mm reducer	20	No.		
R	40mm access plug	23	No.		
S	100mm access plug	13	No.		
T	100mm single branch	1	No.		
U	150mm single branch	15	No.		
	<b>Total Carried to Next Page</b>				

BLOCK B

ITEM	DESCRIPTION	QTY.	UNIT	RATE (KES)	AMOUNT (KES)
	<b>Total From Previous Page</b>				-
V	100 x 50mm floor trap set complete with plastic grating	15	No.		
W	Allow for hydrostatic pressure testing of drainage installation including provision of pipe plugs and other required fittings.	1	Item		
	<i>Sub Total for 1 Floor</i>				-
	<b>TOTAL FOR 9 Floors</b>	9		x 9	-
<b>Total Cost For 1st to 10th floor Foul Drainage Installation</b>					-



## BLOCK B

ITEM	DESCRIPTION	QTY.	UNIT	RATE (KES)	AMOUNT (KES)
	<b>Rain Water Drainage</b>				
	Supply, deliver and install UPVC (Unplasticized Polyvinyl chloride) to (KS ISO 1452 Part 1, 2, 3, 4 & 5) rainwater pipework. Allow for all flanges, couplings, nipples, connector joints, fixing clips holder bats etc as required in running length of pipework but not measured.				
	<b>Piping</b>				
A	100mm ditto	400	LM		
	Extra over piping for fittings:-				
B	100mm ditto	16	No.		
C	100mm sweep bend	2	No.		
D	100mm single branch	13	No.		
E	100mm double branch	7	No.		
F	100mm flat roof rain water outlets	10	No.		
	<b>Testing and Commissioning</b>				
	Allow for testing and commissioning of the rain water drainage installation to the satisfaction of the engineer.				
G		1	Item		
<b>Total Cost For Rain Water Drainage Installation</b>					

BLOCK B

ITEM	DESCRIPTION	AMOUNT (KES)
<u>SUMMARY PAGE</u>		
1.0	Total Cost for Internal Plumbing	
2.0	Total Cost for Roof + Riser	
3.0	Total Cost for Sanitary Fittings Install Only	
4.0	Total Cost Carried For hose reel and associated pipework Installations	
5.0	Total Cost For Portable fire Extinguishers + Hose Reel Pump	
6.0	Total Cost For Dry Riser Installation	
7.0	Total Cost For Ground Floor Foul Drainage Installation	
8.0	Total Cost For 1st to 10th floor Foul Drainage Installation	
9.0	Total Cost For Rain Water Drainage Installation	
<b>Total carried to Mechanical Works Main Summary Page</b>		-

EXTERNAL RETICULATION

ITEM	DESCRIPTION	QTY.	UNIT	RATE (KES)	AMOUNT (KES)
	<p><b><u>EXTERNAL WATER RETICULATION</u></b></p> <p>Supply, install below HDPE PN 16 to (KS ISO 15874 Part 1, 2, 3 &amp; 5) ground pipe providing, fixing, jointing, testing in position &amp; commisioning, including excavation &amp; backfilling as required</p> <hr/> <p><b>Note</b></p> <p>Pipe connection, tees must be electrofusion/butt fussion fittings and be included in the pipe lengths rate. he pipes will be pressure tested before the plastering of wall commences and as per the manufacturers recommended testing pressures.</p> <p><b>Underground Piping complete with Electro-fusion joining of the pipes works</b></p>				
A	100Ø HDPE	1500	m		
B	Ditto 63Ø	350	m		
C	Ditto 50Ø	60	m		
	<p><b>Isolation Valves &amp; Valve Chamber</b></p> <p>Suppy and Install Isolation valves to <b>KS 143 Standard</b>. Standard precast concrete valve chamber made of concrete (1:3:6) base, including formwork, excavations backfilling and disposal.</p>				
D	Ditto 100Ø	8	No.		
E	Ditto 75Ø	4	No.		
F	Ditto 63Ø	3	No.		
G	Ditto 50Ø	28	No.		
	<b>Total Carried to Next Page</b>				

## EXTERNAL RETICULATION

ITEM	DESCRIPTION	QTY.	UNIT	RATE (KES)	AMOUNT (KES)
	<b>From previous page</b>				
	<b>Check/ Non- return Valve Valve Chamber &amp; Valve Chamber</b>				
	Supply and Install brass check valves to (KS ISO 15874 Part 1, 2, 3 & 5) precast concrete valve chamber made of concrete (1:3:6) base, including formwork, excavations backfilling and disposal.				
H	Ditto 100Ø	10	No.		
I	Ditto 75Ø	2	No.		
J	Ditto 50Ø	21	No.		
	<b>Water Meter</b>				
	Supply and Install brass Water Meter to the engineer's approval as kent or equal and approved. Meters to include meter chambers in the rates				
K	Water meter 100Ø	1	No.		
L	Water meter 75Ø	1	No.		
M	Water meter 63Ø	17	No.		
N	Water meter 50Ø	5	No.		
	<b>Garden Stand Pipe</b>				
O	Stand pipe 15mm 2Metres long GMS stand pipe each complete with 15mm lockabler bib tap	28	No.		
	<b>Total Carried to Next Page</b>				

EXTERNAL RETICULATION

ITEM	DESCRIPTION	QTY.	UNIT	RATE (KES)	AMOUNT (KES)
	<b>From previous page</b>				
	Supply and fix the following in PP-R PN 20 water pipes to (KS ISO 15874 Part 1, 2, 3 & 5)with fittings fixed to manufacturer's printed instructions. Tenderers must allow in their pipework tees, reducing branches, reducing tees, reducers, unions, nex hipples adapters etc, and pipes clips or holder bats, plugged and screwed. include for excavation and backfilling				
	<b>Underground PPR Piping</b>				
p	PPR 25Ø	850	m		
Q	Ditto 32Ø	400	m		
	<b>Water Connection</b>				
R	Making necessary connection from the Local municpal line ( water supply ) which is available near the project site, the scope of work include cutting the corporation road and making the same after connection. The contractor responsibility shall include submitting the necessary papers.	1	Lot		
S	Pipe Sleeves 100mm diameter heavy duty PVC Class 41 pipe sleeves for crossing over pathways and driveways. The sleeves will be encased in 150mm concrete sorround.	150	m		
	<b>Total Carried to Next Page</b>				

EXTERNAL RETICULATION

	<p><b>From previous page</b></p>			
	<p><b>Accessories for RC Tanks</b></p>			
A	<p>Accessories for <b>2500m3 Reinforced Concrete Underground water Tank</b> and which are to be in paddle flanges: 2 No. 100mm diameter outlet pipe for domestic booster pumpset, 2 No. 100mm diameter for vent/overflow pipe, 2 No. 20mm diameter for level indicator on the side of the tank with well calibrated scale, air release and drain valve complete with connection adaptors and flanges. and 2 No. 100mm diameter high pressure calming inlet for fitting for the</p>	1	Item	
	<p><b><u>Sterilization</u></b></p>			
C	<p>Allow for flushing out and sterilizing the whole system with chlorine to the satisfaction of the Project Engineer.</p>	1	Sum	
	<p><b><u>Testing and commissioning</u></b></p>			
D	<p>Allow for sterilization of the cold water system, pressure testing and commissioning of the Plumbing installation.</p>	1	Sum	
<b>Total carried to Mechanical Works Main Summary Page</b>				

CLUB HOUSE

ITEM	DESCRIPTION	QTY.	UNIT	RATE (KES)	AMOUNT (KES)
<b>1.0</b>	<b>CLUB HOUSE</b> <b><u>Internal Plumbing Installations</u></b>				
	Supply, deliver install, Test and Commission: PP-R (Polypropylene Random Co-polymer) pipes PN 20 and fittings with polyfusion welded joints to <b>(KS ISO 15874 Part 1, 2, 3 &amp; 5)</b> of approved manufacturer. Rates must allow for all Metal/plastic threaded adaptors where required for the connection of sanitary fixtures, valves, sockets, sliding and fixed joints etc. as required in the running lengths of pipework. The pipes shall run in floors and wall chase. The pipes will be pressure tested before the plastering of wall commences and as per the manufacturers recommended testing pressures.				
(i)	<u>Club House</u>				
	<b>Pipe Works</b>				
A	32mm Ø PPR Pipe	2	LM		
B	Ditto 25mm Ø	20	LM		
	<b>Extra Over Pipe Work</b>				
	<b>Elbows/ Bends</b>				
C	32mm Ø Elbows/ Bends	2	No.		
D	Ditto 25mm Ø	14	No.		
	<b>Equal/Unequal Tees</b>				
E	32 x 32 x 32mm	1	No.		
F	25 x 25 x 25mm	7	No.		
	<b>Reducers</b>				
G	32 x 25mm reducer	1	No.		
	<b>Male/Female brass threaded adaptor</b>				
J	25 x 20mm male/female threaded adaptor	2	No.		
K	25 x 15mm ditto	4	LM		
L	25 x 15mm male threaded bend	14	LM		
<b>Total Carried to Next Page</b>					

CLUB HOUSE

ITEM	DESCRIPTION	QTY.	UNIT	RATE (KES)	AMOUNT (KES)
	<b>Total from Previous Page</b>				
	<b>Isolating valves</b>				
M	25mm Ø Gate Valve as "Pegler" or Equivalent	1	No.		
	<b>Shut off Angle Valve</b>				
N	Brass plated 1/2" angle valve	13	No.		
	<b>Check Meter</b>				
O	50 mm diameter water check meter	1	No.		
	<b>Testing and Commissioning</b>				
P	Allow for pressure testing of the Plumbing installation to the satisfaction of the Engineer including provision of necessary pipe plugs.	1	Item		
<b>Total Cost of Plumbing Installation</b>					



CLUB HOUSE

ITEM	DESCRIPTION	QTY.	UNIT	RATE (KES)	AMOUNT (KES)
<b>2</b>	<b>Risers and Roof Levels</b>				
	<b>Pipe Works</b>				
A	50 mm Ø PPR pipe	10	LM		
B	Ditto 40mm Ø	12	LM		
C	Ditto 32mm Ø	13	LM		
D	Ditto 25mm Ø	6	LM		
	<b>Extra Over Pipe Work</b>				
	<b>Elbows/ Bends</b>				
E	50mm Ø Elbows/ Bends	4	No.		
F	Ditto 40mm Ø	3	No.		
G	Ditto 32mm Ø	3	No.		
H	Ditto 25mm Ø	2	No.		
	<b>Equal/Unequal Tees</b>				
I	50 x 40 x 50mm	4	No.		
J	40 x 40 x 32mm	3	No.		
K	32 x 32 x 32mm	4	No.		
L	32 x 32 x 25mm	4	No.		
M	25 x 25 x 25mm	2	No.		
	<b>Reducers</b>				
O	50 x 40mm reducer	2	No.		
P	40 x 32mm reducer	2	No.		
Q	40 x 32mm reducer	2	No.		
R	32 x 25mm reducer	1	No.		
	<b>Male/Female brass threaded adaptor</b>				
S	40 x 32mm male/female threaded adaptor	2	No.		
T	32 x 25mm male/female threaded adaptor	2	No.		
<b>Total Carried to the Next Page</b>					

CLUB HOUSE

ITEM	DESCRIPTION	QTY.	UNIT	RATE (KES)	AMOUNT (KES)
	<b>Total from Previous Page</b>				
U	<b>Isolating valves</b> 50 mm Ø Gate Valve as "Pegler" or Equivalent	1	No.		
V	<b>Testing and Commissioning</b> Allow for pressure testing of the Plumbing installation to the satisfaction of the Engineer including provision of necessary pipe plugs.	1	Item		
<b>Total Cost of Riser &amp; Roof Level Plumbing</b>					

CLUB HOUSE

ITEM	DESCRIPTION	QTY.	UNIT	RATE (KES)	AMOUNT (KES)
3	<b>SANITARY FITTINGS AND ACCESSORIES INSTALL ONLY</b>				
A	<b>Water Closet (WC) Pan</b> Close Coupled dual flush Floor Standing Close Coupled WC Bowl complete with seat cover, Wc Connector and cistern or approved equivalent (Quote Install Only)	4	No.		
B	<b>Wash Basin</b> WHB basin Full pedestal Wash Basin 450x485x230m White Complte with bottle traps, flexible connection hoses and other accessories with cws only tap (Quote Install Only)	12	No.		
C	<b>Disabled Water Closet (WC) Pan</b> Physically challenges set as Armitage Shanks Doc M Contour 21+ close coupled right hand corner pack, WC pan, Wash basin, water saving delay fill cistern with spatula lever, grab rails, hinged support rail with toilet roll holder, seat no cover with retaining buffers, copper tails on TMV3 mixer tap or equal & approved (Quote Install Only)	1	No.		
D	<b>Urinal</b> Urinal bowl in white colour of size 450 x 685mm with built in spreader and concealed waste trap complete with stainless steel fixing bolts and caps. Complete with exposed Flash Valve (Quote Install Only)	4	No.		
<b>Total Carried to Next Page</b>					

CLUB HOUSE

ITEM	DESCRIPTION	QTY.	UNIT	RATE (KES)	AMOUNT (KES)
	<p><b>Total from Previous Page</b></p> <p><b>Flushing and Sterilization</b> Allow for flushing and sterilization of the entire system to the satisfaction of the Engineer.</p> <p><b>Shower</b> Shower fitting c/w 15mm diameter chrome plated stop cork, Instant shower fitting and 1/2" Cobra 211- 15 Star Pillar tap as Pegler or equal and equivalent</p>	1	Item		
		4	No.		
<b>Total Cost of Sanitary Fittings &amp; Accessories</b>					

CLUB HOUSE

ITEM	DESCRIPTION	QTY.	UNIT	RATE (KES)	AMOUNT (KES)
	<b>FIRE PROTECTION</b>				
	<b>Hose Reel and Associated Pipework</b>				
A	Supply and Install automatic 30 meters long, 25 mm diameter hosereel and nozzle installed to KS 2003:2006	3	No.		
	<b>Associated Pipework</b>				
	GI Class 'B' tubing to KS06-259 with screwed and socketed joints to KS ISO 7-1:1994 including all range piping, fittings, hanagers, supports, brackets, and supports				
B	50mm diameter	34	LM		
C	25mm ditto	12	LM		
	<b>Extra Over Piping For Fittings:-</b>				
	<b>Elbows/Various Bends</b>				
D	50mm bend/elbow	7	No.		
E	25mm ditto	20	No.		
	<b>Equal/Unequal tees</b>				
F	50 x 50 x 50mm tee	10	No.		
G	50 x 50 x 25mm ditto	19	No.		
	<b>Reducers</b>				
H	50 x 25mm reducer	10	No.		
	<b>Unions</b>				
I	50mm diameter union	2	No.		
J	25mm ditto	20	No.		
	<b>Valves</b>				
K	25mm diameter quarter Turn hose reel isolation valve to be as PEGLER or approved equivalent.	3	No.		
<b>Total Cost Carried For hose reel and associated pipework Installations</b>					

CLUB HOUSE

ITEM	DESCRIPTION	QTY.	UNIT	RATE (KES)	AMOUNT (KES)
	<p><b><u>Portable Fire Protection Equipment + Hose</u></b>  <b>Reel Pump</b>  <b>Supply, deliver, install, test and commission</b>                      portable fire protection equipment with initial fill complete with all the necessary mounting accessories.</p> <p><b>A</b> 9 litres, water/carbon dioxide gas extinguisher</p> <p><b>B</b> 4.5kg carbon dioxide gas extinguisher</p> <p><b>C</b> 4.5 kg dry powder extinguisher</p> <p><b>Testing and Commissioning</b>                      Allow for testing and commissioning of the fire pump installation to the satisfaction of the Engineer.</p> <p><b>D</b></p>	<p></p> <p>4</p> <p>4</p> <p>4</p> <p></p> <p>1</p>	<p></p> <p>No.</p> <p>No.</p> <p>No.</p> <p></p> <p>Item</p>	<p></p> <p></p> <p></p> <p></p> <p></p>	<p></p> <p></p> <p></p> <p></p> <p></p>
<b>Total Cost For Portable fire Extinguishers + Hose Reel Pump Installation</b>					

CLUB HOUSE

ITEM	DESCRIPTION	QTY.	UNIT	RATE (KES)	AMOUNT (KES)
	<b><u>Foul Drainage</u></b>				
	Supply, deliver and install the following in uPVC (Unplasticized Polyvinyl chloride) to <b>(KS ISO 1452 Part 1, 2, 3, 4 &amp; 5)</b> Heavy gauge soil and waste system. Allow for all the various sizes of adaptor, connectors, sockets, holderbats, clips etc not measured but required for the satisfactory functioning of the system.				
	<b><u>Piping</u></b>				
A	32mm diameter heavy duty grey uPVC pipe	60	LM		
B	40mm ditto	60	LM		
C	50mm ditto	120	LM		
D	75mm ditto	80	LM		
E	100mm ditto	80	LM		
F	100mm diameter heavy duty golden brown	24	LM		
G	150mm diameter heavy duty golden brown	30	LM		
	<b><u>Extra over uPVC Pipeworks</u></b>				
H	32mm sweep bend	15	No.		
I	40mm sweep bend	60	No.		
J	50mm sweep bend	15	No.		
K	75mm sweep bend	8	No.		
L	100mm sweep bend	22	No.		
M	150mm sweep bend	16	No.		
N	40mm 450 bend	22	No.		
O	50mm 450 bend	15	No.		
P	40mm sweep tee	25	No.		
Q	40 x 32mm reducer	15	No.		
R	75 x 40mm ditto	15	No.		
S	150 x 40mm ditto	8	No.		
T	40mm access plug	22	No.		
<b>Total Carried to Next Page</b>					

CLUB HOUSE

ITEM	DESCRIPTION	QTY.	UNIT	RATE (KES)	AMOUNT (KES)
	<b>Total From Previous Page</b>				
Z	100 x 50mm floor trap set complete with polycarbonate flush grating	17	No.		
	<b>Gulley Trap</b> Gully trap comprising of 100mm diameter golden brown uPVC gully piece, 100mm diameter uPVC trap spigot outlet with screws and washers, and 300 x 300mm masonry gully trap chamber with mild steel plate and a heavy	3	No.		
	<b>Manholes</b> Construct manhole/ inspection chamber size 450 x 600 x 750mm deep internally in 200mm stone walls, 150mm concrete bed, water proof plaster, forming drain channels, medium duty cover frame in cast iron with recessed cover with concrete infill and all necessary formwork, excavation and soil disposal.	4	No.		
	<b>Excavations</b> Excavate trench for pipe not exceeding 100mm diameter and not exceeding 1.5m deep (average 600mm deep) and make good as before.	30	LM		
DD	Allow for hydrostatic pressure testing of drainage installation including provision of pipe plugs and other required fittings.	1	Item		
<b>Total Cost For Ground Floor Foul Drainage Installation</b>					



CLUB HOUSE

ITEM	DESCRIPTION	QTY.	UNIT	RATE (KES)	AMOUNT (KES)
	<p><b>Rain Water Drainage</b></p> <p>Supply, deliver and install UPVC (Unplasticized Polyvinyl chloride) to (KS ISO 1452 Part 1, 2, 3, 4 &amp; 5) rainwater pipework. Allow for all flanges, couplings, nipples, connector joints, fixing clips holder bats etc as required in running length of pipework but not measured.</p>				
A	<p><b>Piping</b></p> <p>100mm ditto</p>	70	LM		
	Extra over piping for fittings:-				
B	100mm ditto	6	No.		
C	100mm sweep bend	2	No.		
D	100mm single branch	4	No.		
E	100mm double branch	3	No.		
F	100mm flat roof rain water outlets	6	No.		
	<p><b>Testing and Commissioning</b></p> <p>Allow for testing and commissioning of the rain water drainage installation to the satisfaction of the engineer.</p>				
G		1	Item		
<b>Total Cost For Rain Water Drainage Installation</b>					

CLUB HOUSE

ITEM	DESCRIPTION	AMOUNT (KES)
<u>SUMMARY PAGE</u>		
1.0	Total Cost for Internal Plumbing	
2.0	Total Cost for Roof + Riser	
3.0	Total Cost for Sanitary Fittings Install Only	
4.0	Total Cost Carried For hose reel and associated pipework Installations	
6.0	Total Cost For Portable fire Extinguishers + Hose Reel Pump Installation	
7.0	Total Cost For Ground Floor Foul Drainage Installation	
9.0	Total Cost For Rain Water Drainage Installation	
<b>Total carried to Mechanical Works Main Summary Page</b>		

SCHOOL

ITEM	DESCRIPTION	QTY.	UNIT	RATE (KES)	AMOUNT (KES)
	<b>SCHOOL</b>				
<b>1.0</b>	<b><u>Internal Plumbing Installations</u></b>				
	Supply, deliver install, Test and Commission: PP-R (Polypropylene Random Co-polymer) pipes PN 20 and fittings with polyfusion welded joints to <b>(KS ISO 15874 Part 1, 2, 3 &amp; 5)</b> of approved manufacturer. Rates must allow for all Metal/plastic threaded adaptors where required for the connection of sanitary fixtures, valves, sockets, sliding and fixed joints etc. as required in the running lengths of pipework. The pipes shall run in floors and wall chase. The pipes will be pressure tested before the plastering of wall commences and as per the manufacturers recommended testing pressures.				
	<b>Pipe Works</b>				
A	32mm Ø PPR Pipe	60	LM		
B	Ditto 25mm Ø	50	LM		
	<b>Extra Over Pipe Work</b>				
	<b>Elbows/ Bends</b>				
C	32mm Ø Elbows/ Bends	20	No.		
D	Ditto 25mm Ø	18	No.		
	<b>Equal/Unequal Tees</b>				
E	32 x 32 x 32mm	21	No.		
F	25 x 25 x 25mm	14	No.		
	<b>Reducers</b>				
G	32 x 25mm reducer	1	No.		
	<b>Male/Female brass threaded adaptor</b>				
J	25 x 20mm male/female threaded adaptor	12	No.		
K	25 x 15mm ditto	10	LM		
L	25 x 15mm male threaded bend	13	LM		
<b>Total Carried to Next Page</b>					

## SCHOOL

ITEM	DESCRIPTION	QTY.	UNIT	RATE (KES)	AMOUNT (KES)
	<b>Total from Previous Page</b>				
	<b>Isolating valves</b>				
M	32mm Ø Gate Valve as "Pegler" or Equivalent	2	No.		
	<b>Shut off Angle Valve</b>				
N	Brass plated 1/2" angle valve	16	No.		
	<b>Check Meter</b>				
O	50 mm diameter water check meter	1	No.		
	<b>Testing and Commissioning</b>				
P	Allow for pressure testing of the Plumbing installation to the satisfaction of the Engineer including provision of necessary pipe plugs.	1	Item		
	<b>TOTAL Internal Plumbing</b>				
<b>Total Cost of Plumbing Installation</b>					

## SCHOOL

ITEM	DESCRIPTION	QTY.	UNIT	RATE (KES)	AMOUNT (KES)
<b>2</b>	<b>Risers and Roof Levels</b>				
	<b>Pipe Works</b>				
A	50 mm Ø PPR pipe	28	LM		
B	Ditto 40mm Ø	12	LM		
C	Ditto 32mm Ø	13	LM		
D	Ditto 25mm Ø	6	LM		
	<b>Extra Over Pipe Work</b>				
	<b>Elbows/ Bends</b>				
E	50mm Ø Elbows/ Bends	4	No.		
F	Ditto 40mm Ø	3	No.		
G	Ditto 32mm Ø	3	No.		
H	Ditto 25mm Ø	2	No.		
	<b>Equal/Unequal Tees</b>				
I	50 x 40 x 50mm	4	No.		
J	40 x 40 x 32mm	3	No.		
K	32 x 32 x 32mm	4	No.		
L	32 x 32 x 25mm	4	No.		
M	25 x 25 x 25mm	2	No.		
	<b>Reducers</b>				
O	50 x 40mm reducer	2	No.		
P	40 x 32mm reducer	2	No.		
Q	40 x 32mm reducer	2	No.		
R	32 x 25mm reducer	1	No.		
	<b>Male/Female brass threaded adaptor</b>				
S	40 x 32mm male/female threaded adaptor	2	No.		
T	32 x 25mm male/female threaded adaptor	2	No.		
<b>Total Carried to the Next Page</b>					

SCHOOL

ITEM	DESCRIPTION	QTY.	UNIT	RATE (KES)	AMOUNT (KES)
	<b>Total from Previous Page</b>				
U	<b>Isolating valves</b> 50 mm Ø Gate Valve as "Pegler" or Equivalent	2	No.		
V	<b>Testing and Commissioning</b> Allow for pressure testing of the Plumbing installation to the satisfaction of the Engineer including provision of necessary pipe plugs.	1	Item		
<b>Total Cost of Riser &amp; Roof Level Plumbing</b>					

## SCHOOL

ITEM	DESCRIPTION	QTY.	UNIT	RATE (KES)	AMOUNT (KES)
3	<b>SANITARY FITTINGS AND ACCESSORIES INSTALL ONLY</b>				
A	<b>Water Closet (WC) Pan</b> Close Coupled dual flush Floor Standing Close Coupled WC Bowl complete with seat cover, Wc Connector and cistern or approved equivalent (Quote Install Only)	10	No.		
B	<b>Wash Basin</b> WHB basin Full pedestal Wash Basin 450x485x230m White Complete with bottle traps, flexible connection hoses and other accessories with cws only tap (Quote Install	10	No.		
C	<b>Disabled Water Closet (WC) Pan</b> Physically challenges set as Armitage Shanks Doc M Contour 21+ close coupled right hand corner pack, WC pan, Wash basin, water saving delay fill cistern with spatula lever, grab rails, hinged support rail with toilet roll holder, seat no cover with retaining buffers, copper tails on TMV3 mixer tap or equal & approved (Quote Install Only)	1	No.		
D	<b>Urinal</b> Urinal bowl in white colour of size 450 x 685mm with built in spreader and concealed waste trap complete with stainless steel fixing bolts and caps. Complete with exposed Flash Valve (Quote Install Only)	4	No.		
E	<b>Flushing and Sterilization</b> Allow for flushing and sterilization of the entire system to the satisfaction of the Engineer.	1	Item		
F	<b>kitchen sink</b> Stainless steel kitchen sink single drain, single bowl complete overflow and 40mm diameter plastic tubular p-trap PVC Bottle Trap and waste 1.5in x 40, Long Neck Wall type Bib Tap (Quote Install Only)	3	No.		
<b>Total Cost of Sanitary Fittings &amp; Accessories</b>					

## SCHOOL

ITEM	DESCRIPTION	QTY.	UNIT	RATE (KES)	AMOUNT (KES)
	<b>FIRE PROTECTION</b>				
	<b>Hose Reel and Associated Pipework</b>				
A	Supply and Install automatic 30 meters long, 25 mm diameter hosereel and nozzle installed to KS 2003:2006	2	No.		
	<b>Associated Pipework</b>				
	GI Class 'B' tubing to KS06-259 with screwed and socketed joints to KS ISO 7-1:1994 including all range piping, fittings, hanagers, supports, brackets, and supports				
B	50mm diameter	25	LM		
C	25mm ditto	4	LM		
	<b>Extra Over Piping For Fittings:-</b>				
	<b>Elbows/Various Bends</b>				
D	50mm bend/elbow	6	No.		
E	25mm ditto	5	No.		
	<b>Equal/Unequal tees</b>				
F	50 x 50 x 50mm tee	3	No.		
G	50 x 50 x 25mm ditto	3	No.		
	<b>Reducers</b>				
H	50 x 25mm reducer	3	No.		
	<b>Unions</b>				
I	50mm diameter union	2	No.		
J	25mm ditto	8	No.		
	<b>Valves</b>				
K	25mm diameter quarter Turn hose reel isolation valve to be as PEGLER or approved equivalent.	2	No.		
<b>Total Cost Carried For hose reel and associated pipework Installations</b>					



SCHOOL

ITEM	DESCRIPTION	QTY.	UNIT	RATE (KES)	AMOUNT (KES)
	<p><b><u>Portable Fire Protection Equipment + Hose Reel Pump</u></b>  <b>Supply, deliver, install, test and commission</b>                      portable fire protection equipment with initial fill complete with all the necessary mounting accessories.</p> <p><b>A</b> 9 litres, water/carbon dioxide gas extinguisher</p> <p><b>B</b> 4.5kg carbon dioxide gas extinguisher</p> <p><b>C</b> 4.5 kg dry powder extinguisher</p> <p><b>Testing and Commissioning</b>                      Allow for testing and commissioning of the fire pump installation to the satisfaction of the Engineer.</p> <p><b>D</b></p>	<p></p> <p>4</p> <p>4</p> <p>4</p> <p>1</p>	<p></p> <p>No.</p> <p>No.</p> <p>No.</p> <p>Item</p>	<p></p> <p></p> <p></p> <p></p>	<p></p> <p></p> <p></p> <p></p>
<b>Total Cost For Portable fire Extinguishers + Hose Reel Pump Installation</b>					

## SCHOOL

ITEM	DESCRIPTION	QTY.	UNIT	RATE (KES)	AMOUNT (KES)
	<b><u>Foul Drainage</u></b>				
	Supply, deliver and install the following in uPVC (Unplasticized Polyvinyl chloride) to <b>(KS ISO 1452 Part 1, 2, 3, 4 &amp; 5)</b> Heavy gauge soil and waste system. Allow for all the various sizes of adaptor, connectors, sockets, holderbats, clips etc not measured but required for the satisfactory functioning of the system.				
	<b><u>Piping</u></b>				
A	32mm diameter heavy duty grey uPVC pipe	32	LM		
B	40mm ditto	100	LM		
C	50mm ditto	120	LM		
D	75mm ditto	12	LM		
E	100mm ditto	32	LM		
F	100mm diameter heavy duty golden brown	150	LM		
G	150mm diameter heavy duty golden brown	44	LM		
	<b><u>Extra over uPVC Pipeworks</u></b>				
H	32mm sweep bend	15	No.		
I	40mm sweep bend	60	No.		
J	50mm sweep bend	15	No.		
K	75mm sweep bend	8	No.		
L	100mm sweep bend	22	No.		
M	150mm sweep bend	16	No.		
N	40mm 450 bend	22	No.		
O	50mm 450 bend	15	No.		
P	40mm sweep tee	25	No.		
Q	40 x 32mm reducer	15	No.		
R	75 x 40mm ditto	15	No.		
S	150 x 40mm ditto	8	No.		
T	40mm access plug	22	No.		
U	100mm bend WC connector	13	No.		
V	40mm bottle 'p' trap	15	No.		
	<b>Total Carried to Next Page</b>				

## SCHOOL

ITEM	DESCRIPTION	QTY.	UNIT	RATE (KES)	AMOUNT (KES)
	<b>Total From Previous Page</b>				
Z	100 x 50mm floor trap set complete with polycarbonate flush grating	17	No.		
AA	<b>Gulley Trap</b> Gully trap comprising of 100mm diameter golden brown uPVC gully piece, 100mm diameter uPVC trap spigot outlet with screws and washers, and 300 x 300mm masonry gully trap chamber with mild steel plate and a heavy	4	No.		
BB	<b>Manholes</b> Construct manhole/ inspection chamber size 450 x 600 x 750mm deep internally in 200mm stone walls, 150mm concrete bed, water proof plaster, forming drain channels, medium duty cover frame in cast iron with recessed cover with concrete infill and all necessary formwork, excavation and soil disposal.	14	No.		
CC	<b>Excavations</b> Excavate trench for pipe not exceeding 100mm diameter and not exceeding 1.5m deep (average 600mm deep) and make good as before.	120	LM		
DD	Allow for hydrostatic pressure testing of drainage installation including provision of pipe plugs and other required fittings.	1	Item		
<b>Total Cost For Ground Floor Foul Drainage Installation</b>					

## SCHOOL

ITEM	DESCRIPTION	QTY.	UNIT	RATE (KES)	AMOUNT (KES)
	<b>Rain Water Drainage</b>				
	Supply, deliver and install UPVC (Unplasticized Polyvinyl chloride) to (KS ISO 1452 Part 1, 2, 3, 4 & 5) rainwater pipework. Allow for all flanges, couplings, nipples, connector joints, fixing clips holder bats etc as required in running length of pipework but not measured.				
	<b>Piping</b>				
A	100mm ditto	150	LM		
	Extra over piping for fittings:-				
B	100mm ditto	20	No.		
C	100mm sweep bend	20	No.		
D	100mm single branch	18	No.		
E	100mm double branch	12	No.		
F	100mm flat roof rain water outlets	10	No.		
	<b>Testing and Commissioning</b>				
G	Allow for testing and commissioning of the rain water drainage installation to the satisfaction of the engineer.	1	Item		
<b>Total Cost For Rain Water Drainage Installation</b>					

SCHOOL

ITEM	DESCRIPTION	AMOUNT (KES)
<u>SUMMARY PAGE</u>		
1.0	Total Cost for Internal Plumbing	
2.0	Total Cost for Roof + Riser	
3.0	Total Cost for Sanitary Fittings Install Only	
4.0	Total Cost Carried For hose reel and associated pipework Installations	
5.0	Total Cost For Portable fire Extinguishers + Hose Reel Pump Installation	
6.0	Total Cost For Ground Floor Foul Drainage Installation	
7.0	Total Cost For Rain Water Drainage Installation	
<b>Total carried to Mechanical Works Main Summary Page</b>		

MARKET

ITEM	DESCRIPTION	QTY.	UNIT	RATE (KES)	AMOUNT (KES)
	<b>MARKET</b>				
<b>1.0</b>	<b><u>Internal Plumbing Installations</u></b>				
	Supply, deliver install, Test and Commission: PP-R (Polypropylene Random Co-polymer) pipes PN 20 and fittings with polyfusion welded joints to (KS ISO 15874 Part 1, 2, 3 & 5)of approved manufacturer. Rates must allow for all Metal/plastic threaded adaptors where required for the connection of sanitary fixtures, valves, sockets, sliding and fixed joints etc. as required in the running lengths of pipework. The pipes shall run in floors and wall chase. The pipes will be pressure tested before the plastering of wall commences and as per the manufacturers recommended testing pressures.				
	<b>Pipe Works</b>				
A	32mm Ø PPR Pipe	40	LM		
B	Ditto 25mm Ø	33	LM		
	<b>Extra Over Pipe Work</b>				
	<b>Elbows/ Bends</b>				
C	32mm Ø Elbows/ Bends	20	No.		
D	Ditto 25mm Ø	18	No.		
	<b>Equal/Unequal Tees</b>				
E	32 x 32 x 32mm	21	No.		
F	25 x 25 x 25mm	14	No.		
	<b>Reducers</b>				
G	32 x 25mm reducer	1	No.		
	<b>Male/Female brass threaded adaptor</b>				
J	25 x 20mm male/female threaded adaptor	12	No.		
K	25 x 15mm ditto	10	LM		
L	25 x 15mm male threaded bend	13	LM		
<b>Total Carried to Next Page</b>					

MARKET

ITEM	DESCRIPTION	QTY.	UNIT	RATE (KES)	AMOUNT (KES)
	<b>Total from Previous Page</b>				
	<b>Isolating valves</b>				
M	32mm Ø Gate Valve as "Pegler" or Equivalent	2	No.		
	<b>Shut off Angle Valve</b>				
N	Brass plated 1/2" angle valve	16	No.		
	<b>Check Meter</b>				
O	50 mm diameter water check meter	1	No.		
	<b>Testing and Commissioning</b>				
P	Allow for pressure testing of the Plumbing installation to the satisfaction of the Engineer including provision of necessary pipe plugs.	1	Item		
	<b>TOTAL Internal Plumbing</b>				
<b>Total Cost of Plumbing Installation</b>					

MARKET

ITEM	DESCRIPTION	QTY.	UNIT	RATE (KES)	AMOUNT (KES)
<b>2</b>	<b>Risers and Roof Levels</b>				
	<b>Pipe Works</b>				
A	50 mm Ø PPR pipe	28	LM		
B	Ditto 40mm Ø	12	LM		
C	Ditto 32mm Ø	13	LM		
D	Ditto 25mm Ø	6	LM		
	<b>Extra Over Pipe Work</b>				
	<b>Elbows/ Bends</b>				
E	50mm Ø Elbows/ Bends	4	No.		
F	Ditto 40mm Ø	3	No.		
G	Ditto 32mm Ø	3	No.		
H	Ditto 25mm Ø	2	No.		
	<b>Equal/Unequal Tees</b>				
I	50 x 40 x 50mm	4	No.		
J	40 x 40 x 32mm	3	No.		
K	32 x 32 x 32mm	4	No.		
L	32 x 32 x 25mm	4	No.		
M	25 x 25 x 25mm	2	No.		
	<b>Reducers</b>				
O	50 x 40mm reducer	2	No.		
P	40 x 32mm reducer	2	No.		
Q	40 x 32mm reducer	2	No.		
R	32 x 25mm reducer	1	No.		
	<b>Male/Female brass threaded adaptor</b>				
S	40 x 32mm male/female threaded adaptor	2	No.		
T	32 x 25mm male/female threaded adaptor	2	No.		
<b>Total Carried to the Next Page</b>					



MARKET

ITEM	DESCRIPTION	QTY.	UNIT	RATE (KES)	AMOUNT (KES)
	<b>Total from Previous Page</b>				
U	<b>Isolating valves</b> 50 mm Ø Gate Valve as "Pegler" or Equivalent	2	No.		
V	<b>Testing and Commissioning</b> Allow for pressure testing of the Plumbing installation to the satisfaction of the Engineer including provision of necessary pipe plugs.	1	Item		
<b>Total Cost of Riser &amp; Roof Level Plumbing</b>					

MARKET

ITEM	DESCRIPTION	QTY.	UNIT	RATE (KES)	AMOUNT (KES)
3	<b>SANITARY FITTINGS AND ACCESSORIES INSTALL ONLY</b>				
A	<b>Water Closet (WC) Pan</b> Close Coupled dual flush Floor Standing Close Coupled WC Bowl complete with seat cover, Wc Connector and cistern or approved equivalent (Quote Install Only)	8	No.		
B	<b>Wash Basin</b> WHB basin Full pedestal Wash Basin 450x485x230m White Complete with bottle traps, flexible connection hoses and other accessories with cws only tap (Quote Install Only)	4	No.		
C	<b>Disabled Water Closet (WC) Pan</b> Physically challenges set as Armitage Shanks Doc M Contour 21+ close coupled right hand corner pack, WC pan, Wash basin, water saving delay fill cistern with spatula lever, grab rails, hinged support rail with toilet roll holder, seat no cover with retaining buffers, copper tails on TMV3 mixer tap or equal & approved (Quote Install Only)	1	No.		
D	<b>Urinal</b> Urinal bowl in white colour of size 450 x 685mm with built in spreader and concealed waste trap complete with stainless steel fixing bolts and caps. Complete with exposed Flash Valve (Quote Install Only)	2	No.		
<b>Total Carried to Next Page</b>					

MARKET

ITEM	DESCRIPTION	QTY.	UNIT	RATE (KES)	AMOUNT (KES)
E	<p><b>Total from Previous Page</b></p> <p><b>Flushing and Sterilization</b>                      Allow for flushing and sterilization of the entire system to the satisfaction of the Engineer.</p>	1	Item		
<b>Total Cost of Sanitary Fittings &amp; Accessories</b>					

MARKET

ITEM	DESCRIPTION	QTY.	UNIT	RATE (KES)	AMOUNT (KES)
	<b>FIRE PROTECTION</b>				
	<b>Hose Reel and Associated Pipework</b>				
A	Supply and Install automatic 30 meters long, 25 mm diameter hosereel and nozzle installed to <b>KS 2003:2006</b>	4	No.		
	<b>Associated Pipework</b>				
	GI Class 'B' tubing to KS06-259 with screwed and socketed joints to KS ISO 7-1:1994 including all range piping, fittings, hanagers, supports, brackets, and supports				
B	50mm diameter	36	LM		
C	25mm ditto	12	LM		
	<b>Extra Over Piping For Fittings:-</b>				
	<b>Elbows/Various Bends</b>				
D	50mm bend/elbow	6	No.		
E	25mm ditto	8	No.		
	<b>Equal/Unequal tees</b>				
F	50 x 50 x 50mm tee	4	No.		
G	50 x 50 x 25mm ditto	4	No.		
	<b>Reducers</b>				
H	50 x 25mm reducer	4	No.		
	<b>Unions</b>				
I	50mm diameter union	4	No.		
J	25mm ditto	8	No.		
	<b>Valves</b>				
K	25mm diameter quarter Turn hose reel isolation valve to be as PEGLER or approved equivalent.	4	No.		
<b>Total Cost Carried For hose reel and associated pipework Installations</b>					

MARKET

ITEM	DESCRIPTION	QTY.	UNIT	RATE (KES)	AMOUNT (KES)
	<b><u>Portable Fire Protection Equipment + Hose</u></b>				
	<b>Reel Pump</b>				
	<b>Supply, deliver, install, test and commission</b>				
	portable fire protection equipment with initial fill complete with all the necessary mounting accessories.				
A	9 litres, water/carbon dioxide gas extinguisher	4	No.		
B	4.5kg carbon dioxide gas extinguisher	4	No.		
C	4.5 kg dry powder extinguisher	4	No.		
	<b>Hose Reel Pump</b>				
D	Supply, Install hose reel water supply boosting set. Flow 8 m <sup>3</sup> /h at a head of 20 m , Duty + Standby	1	Set		
	<b>Testing and Commissioning</b>				
E	Allow for testing and commissioning of the fire pump installation to the satisfaction of the Engineer.	1	Item		
<b>Total Cost For Portable fire Extinguishers + Hose Reel Pump Installation</b>					

MARKET

ITEM	DESCRIPTION	QTY.	UNIT	RATE (KES)	AMOUNT (KES)
	<b><u>Foul Drainage</u></b>				
	Supply, deliver and install the following in uPVC (Unplasticized Polyvinyl chloride) to <b>(KS ISO 1452 Part 1, 2, 3, 4 &amp; 5)</b> Heavy gauge soil and waste system. Allow for all the various sizes of adaptor, connectors, sockets, holderbats, clips etc not measured but required for the satisfactory functioning of the system.				
	<b><u>Piping</u></b>				
A	32mm diameter heavy duty grey uPVC pipe	32	LM		
B	40mm ditto	50	LM		
C	50mm ditto	56	LM		
D	75mm ditto	12	LM		
E	100mm ditto	32	LM		
F	100mm diameter heavy duty golden brown	80	LM		
G	150mm diameter heavy duty golden brown	44	LM		
	<b><u>Extra over uPVC Pipeworks</u></b>				
H	32mm sweep bend	15	No.		
I	40mm sweep bend	60	No.		
J	50mm sweep bend	15	No.		
K	75mm sweep bend	8	No.		
L	100mm sweep bend	22	No.		
M	150mm sweep bend	16	No.		
N	40mm 450 bend	22	No.		
O	50mm 450 bend	15	No.		
P	40mm sweep tee	25	No.		
Q	40 x 32mm reducer	15	No.		
R	75 x 40mm ditto	15	No.		
S	150 x 40mm ditto	8	No.		
T	40mm access plug	22	No.		
U	100mm bend WC connector	13	No.		
V	40mm bottle 'p' trap	15	No.		
	<b>Total Carried to Next Page</b>				

MARKET

ITEM	DESCRIPTION	QTY.	UNIT	RATE (KES)	AMOUNT (KES)
	<b>Total From Previous Page</b>				
Z	100 x 50mm floor trap set complete with polycarbonate flush grating	17	No.		
AA	<b>Gulley Trap</b> Gully trap comprising of 100mm diameter golden brown uPVC gully piece, 100mm diameter uPVC trap spigot outlet with screws and washers, and 300 x 300mm masonry gully trap chamber with mild steel plate and a heavy	4	No.		
BB	<b>Manholes</b> Construct manhole/ inspection chamber size 450 x 600 x 750mm deep internally in 200mm stone walls, 150mm concrete bed, water proof plaster, forming drain channels, medium duty cover frame in cast iron with recessed cover with concrete infill and all necessary formwork, excavation and soil disposal.	10	No.		
CC	<b>Excavations</b> Excavate trench for pipe not exceeding 100mm diameter and not exceeding 1.5m deep (average 600mm deep) and make good as before.	120	LM		
DD	Allow for hydrostatic pressure testing of drainage installation including provision of pipe plugs and other required fittings.	1	Item		
<b>Total Cost For Ground Floor Foul Drainage Installation</b>					

MARKET

ITEM	DESCRIPTION	QTY.	UNIT	RATE (KES)	AMOUNT (KES)
	<p><b>Rain Water Drainage</b></p> <p>Supply, deliver and install UPVC (Unplasticized Polyvinyl chloride) to (KS ISO 1452 Part 1, 2, 3, 4 &amp; 5) rainwater pipework. Allow for all flanges, couplings, nipples, connector joints, fixing clips holder bats etc as required in running length of pipework but not measured.</p>				
	<p><b>Piping</b></p>				
A	100mm ditto	200	LM		
	Extra over piping for fittings:-				
B	100mm ditto	16	No.		
C	100mm sweep bend	2	No.		
D	100mm single branch	13	No.		
E	100mm double branch	7	No.		
F	100mm flat roof rain water outlets	10	No.		
	<p><b>Testing and Commissioning</b></p>				
G	Allow for testing and commissioning of the rain water drainage installation to the satisfaction of the engineer.	1	Item		



MARKET

	<b>Total Cost For Rain Water Drainage Installation</b>	
--	--	--

ITEM	DESCRIPTION	AMOUNT (KES)
	<u><b>SUMMARY PAGE</b></u>	
1.0	<b>Total Cost for Internal Plumbing</b>	
2.0	<b>Total Cost for Roof + Riser</b>	
3.0	<b>Total Cost for Sanitary Fittings Install Only</b>	
4.0	<b>Total Cost Carried For hose reel and associated pipework Installations</b>	
5.0	<b>Total Cost For Portable fire Extinguishers + Hose Reel Pump Installation</b>	
6.0	<b>Total Cost For Ground Floor Foul Drainage Installation</b>	
7.0	<b>Total Cost For Rain Water Drainage Installation</b>	
	<b>Total carried to Mechanical Works Main Summary Page</b>	

COMMUNITY CENTRE

ITEM	DESCRIPTION	QTY.	UNIT	RATE (KES)	AMOUNT (KES)
	<b>COMMUNITY CENTER</b>				
<b>1.0</b>	<b><u>Internal Plumbing Installations</u></b>				
	Supply, deliver install, Test and Commission: PP-R (Polypropylene Random Co-polymer) pipes PN 20 and fittings with polyfusion welded joints to <b>(KS ISO 15874 Part 1, 2, 3 &amp; 5)</b> of approved manufacturer. Rates must allow for all Metal/plastic threaded adaptors where required for the connection of sanitary fixtures, valves, sockets, sliding and fixed joints etc. as required in the running lengths of pipework. The pipes shall run in floors and wall chase. The pipes will be pressure tested before the plastering of wall commences and as per the manufacturers recommended testing pressures.				
	<b>Pipe Works</b>				
A	32mm Ø PPR Pipe	40	LM		
B	Ditto 25mm Ø	33	LM		
	<b>Extra Over Pipe Work</b>				
	<b>Elbows/ Bends</b>				
C	32mm Ø Elbows/ Bends	20	No.		
D	Ditto 25mm Ø	18	No.		
	<b>Equal/Unequal Tees</b>				
E	32 x 32 x 32mm	21	No.		
F	25 x 25 x 25mm	14	No.		
	<b>Reducers</b>				
G	32 x 25mm reducer	1	No.		
	<b>Male/Female brass threaded adaptor</b>				
J	25 x 20mm male/female threaded adaptor	12	No.		
K	25 x 15mm ditto	10	LM		
L	25 x 15mm male threaded bend	13	LM		
<b>Total Carried to Next Page</b>					

COMMUNITY CENTRE

ITEM	DESCRIPTION	QTY.	UNIT	RATE (KES)	AMOUNT (KES)
	<b>Total from Previous Page</b>				
	<b>Isolating valves</b>				
M	32mm Ø Gate Valve as "Pegler" or Equivalent	2	No.		
	<b>Shut off Angle Valve</b>				
N	Brass plated 1/2" angle valve	16	No.		
	<b>Check Meter</b>				
O	50 mm diameter water check meter	1	No.		
	<b>Testing and Commissioning</b>				
P	Allow for pressure testing of the Plumbing installation to the satisfaction of the Engineer including provision of necessary pipe plugs.	1	Item		
	<b>TOTAL Internal Plumbing</b>				
<b>Total Cost of Plumbing Installation</b>					

COMMUNITY CENTRE

ITEM	DESCRIPTION	QTY.	UNIT	RATE (KES)	AMOUNT (KES)
<b>2</b>	<b>Risers and Roof Levels</b>				
	<b>Pipe Works</b>				
A	50 mm Ø PPR pipe	28	LM		
B	Ditto 40mm Ø	12	LM		
C	Ditto 32mm Ø	13	LM		
D	Ditto 25mm Ø	6	LM		
	<b>Extra Over Pipe Work</b>				
	<b>Elbows/ Bends</b>				
E	50mm Ø Elbows/ Bends	4	No.		
F	Ditto 40mm Ø	3	No.		
G	Ditto 32mm Ø	3	No.		
H	Ditto 25mm Ø	2	No.		
	<b>Equal/Unequal Tees</b>				
I	50 x 40 x 50mm	4	No.		
J	40 x 40 x 32mm	3	No.		
K	32 x 32 x 32mm	4	No.		
L	32 x 32 x 25mm	4	No.		
M	25 x 25 x 25mm	2	No.		
	<b>Reducers</b>				
O	50 x 40mm reducer	2	No.		
P	40 x 32mm reducer	2	No.		
Q	40 x 32mm reducer	2	No.		
R	32 x 25mm reducer	1	No.		
	<b>Male/Female brass threaded adaptor</b>				
S	40 x 32mm male/female threaded adaptor	2	No.		
T	32 x 25mm male/female threaded adaptor	2	No.		
<b>Total Carried to the Next Page</b>					

COMMUNITY CENTRE

ITEM	DESCRIPTION	QTY.	UNIT	RATE (KES)	AMOUNT (KES)
	<b>Total from Previous Page</b>				
U	<b>Isolating valves</b> 50 mm Ø Gate Valve as "Pegler" or Equivalent	2	No.		
V	<b>Testing and Commissioning</b> Allow for pressure testing of the Plumbing installation to the satisfaction of the Engineer including provision of necessary pipe plugs.	1	Item		
<b>Total Cost of Riser &amp; Roof Level Plumbing</b>					

COMMUNITY CENTRE

ITEM	DESCRIPTION	QTY.	UNIT	RATE (KES)	AMOUNT (KES)
3	<b>SANITARY FITTINGS AND ACCESSORIES INSTALL ONLY</b>				
A	<b>Water Closet (WC) Pan</b> Close Coupled dual flush Floor Standing Close Coupled WC Bowl complete with seat cover, Wc Connector and cistern or approved equivalent (Quote Install Only)	8	No.		
B	<b>Wash Basin</b> WHB basin Full pedestal Wash Basin 450x485x230m White Complete with bottle traps, flexible connection hoses and other accessories with cws only tap (Quote Install Only)	13	No.		
C	<b>Disabled Water Closet (WC) Pan</b> Physically challenges set as Armitage Shanks Doc M Contour 21+ close coupled right hand corner pack, WC pan, Wash basin, water saving delay fill cistern with spatula lever, grab rails, hinged support rail with toilet roll holder, seat no cover with retaining buffers, copper tails on TMV3 mixer tap or equal & approved (Quote Install Only)	2	No.		
D	<b>Urinal</b> Urinal bowl in white colour of size 450 x 685mm with built in spreader and concealed waste trap complete with stainless steel fixing bolts and caps. Complete with exposed Flash Valve (Quote Install Only)	6	No.		
<b>Total Carried to Next Page</b>					

COMMUNITY CENTRE

ITEM	DESCRIPTION	QTY.	UNIT	RATE (KES)	AMOUNT (KES)
E	<p><b>Total from Previous Page</b></p> <p><b>Flushing and Sterilization</b>                      Allow for flushing and sterilization of the entire system to the satisfaction of the Engineer.</p>	1	Item		
<b>Total Cost of Sanitary Fittings &amp; Accessories</b>					

COMMUNITY CENTRE

ITEM	DESCRIPTION	QTY.	UNIT	RATE (KES)	AMOUNT (KES)
	<b>FIRE PROTECTION</b>				
	<b>Hose Reel and Associated Pipework</b>				
A	Supply and Install automatic 30 meters long, 25 mm diameter hosereel and nozzle installed to KS 2003:2006	2	No.		
	<b>Associated Pipework</b>				
	GI Class 'B' tubing to KS06-259 with screwed and socketed joints to KS ISO 7-1:1994 including all range piping, fittings, hanagers, supports, brackets, and supports				
B	50mm diameter	25	LM		
C	25mm ditto	4	LM		
	<b>Extra Over Piping For Fittings:-</b>				
	<b>Elbows/Various Bends</b>				
D	50mm bend/elbow	6	No.		
E	25mm ditto	5	No.		
	<b>Equal/Unequal tees</b>				
F	50 x 50 x 50mm tee	3	No.		
G	50 x 50 x 25mm ditto	3	No.		
	<b>Reducers</b>				
H	50 x 25mm reducer	3	No.		
	<b>Unions</b>				
I	50mm diameter union	2	No.		
J	25mm ditto	8	No.		
	<b>Valves</b>				
K	25mm diameter quarter Turn hose reel isolation valve to be as PEGLER or approved equivalent.	2	No.		
<b>Total Cost Carried For hose reel and associated pipework Installations</b>					



COMMUNITY CENTRE

ITEM	DESCRIPTION	QTY.	UNIT	RATE (KES)	AMOUNT (KES)
	<b><u>Portable Fire Protection Equipment + Hose Reel Pump</u></b> Supply, deliver, install, test and commission portable fire protection equipment with initial fill complete with all the necessary mounting accessories.				
A	9 litres, water/carbon dioxide gas extinguisher	4	No.		
B	4.5kg carbon dioxide gas extinguisher	4	No.		
C	4.5 kg dry powder extinguisher	4	No.		
	<b>Hose Reel Pump</b>				
D	Supply, Install hose reel water supply boosting set. Flow 8 m <sup>3</sup> /h at a head of 20 m , Duty + Standby	1	Set		
	<b>Testing and Commissioning</b>				
E	Allow for testing and commissioning of the fire pump installation to the satisfaction of the Engineer.	1	Item		
<b>Total Cost For Portable fire Extinguishers + Hose Reel Pump Installation</b>					

COMMUNITY CENTRE

ITEM	DESCRIPTION	QTY.	UNIT	RATE (KES)	AMOUNT (KES)
	<b><u>Foul Drainage</u></b>				
	Supply, deliver and install the following in uPVC (Unplasticized Polyvinyl chloride) to (KS ISO 1452 Part 1, 2, 3, 4 & 5) Heavy gauge soil and waste system. Allow for all the various sizes of adaptor, connectors, sockets, holderbats, clips etc not measured but required for the satisfactory functioning of the system.				
	<b><u>Piping</u></b>				
A	32mm diameter heavy duty grey uPVC pipe	32	LM		
B	40mm ditto	50	LM		
C	50mm ditto	56	LM		
D	75mm ditto	12	LM		
E	100mm ditto	32	LM		
F	100mm diameter heavy duty golden brown	80	LM		
G	150mm diameter heavy duty golden brown	44	LM		
	<b><u>Extra over uPVC Pipeworks</u></b>				
H	32mm sweep bend	15	No.		
I	40mm sweep bend	60	No.		
J	50mm sweep bend	15	No.		
K	75mm sweep bend	8	No.		
L	100mm sweep bend	22	No.		
M	150mm sweep bend	16	No.		
N	40mm 450 bend	22	No.		
O	50mm 450 bend	15	No.		
P	40mm sweep tee	25	No.		
Q	40 x 32mm reducer	15	No.		
R	75 x 40mm ditto	15	No.		
S	150 x 40mm ditto	8	No.		
T	40mm access plug	22	No.		
U	100mm bend WC connector	13	No.		
V	40mm bottle 'p' trap	15	No.		
	<b>Total Carried to Next Page</b>				

COMMUNITY CENTRE

ITEM	DESCRIPTION	QTY.	UNIT	RATE (KES)	AMOUNT (KES)
	<b>Total From Previous Page</b>				
Z	100 x 50mm floor trap set complete with polycarbonate flush grating	17	No.		
AA	<b>Gulley Trap</b> Gully trap comprising of 100mm diameter golden brown uPVC gully piece, 100mm diameter uPVC trap spigot outlet with screws and washers, and 300 x 300mm masonry gully trap chamber with mild steel plate and a heavy	4	No.		
BB	<b>Manholes</b> Construct manhole/ inspection chamber size 450 x 600 x 750mm deep internally in 200mm stone walls, 150mm concrete bed, water proof plaster, forming drain channels, medium duty cover frame in cast iron with recessed cover with concrete infill and all necessary formwork, excavation and soil disposal.	10	No.		
CC	<b>Excavations</b> Excavate trench for pipe not exceeding 100mm diameter and not exceeding 1.5m deep (average 600mm deep) and make good as before.	120	LM		
DD	Allow for hydrostatic pressure testing of drainage installation including provision of pipe plugs and other required fittings.	1	Item		
<b>Total Cost For Ground Floor Foul Drainage Installation</b>					

COMMUNITY CENTRE

ITEM	DESCRIPTION	QTY.	UNIT	RATE (KES)	AMOUNT (KES)
	<b>Rain Water Drainage</b>				
	Supply, deliver and install UPVC (Unplasticized Polyvinyl chloride) to (KS ISO 1452 Part 1, 2, 3, 4 & 5) rainwater pipework. Allow for all flanges, couplings, nipples, connector joints, fixing clips holder bats etc as required in running length of pipework but not measured.				
	<b>Piping</b>				
A	100mm ditto	200	LM		
	Extra over piping for fittings:-				
B	100mm ditto	16	No.		
C	100mm sweep bend	2	No.		
D	100mm single branch	13	No.		
E	100mm double branch	7	No.		
F	100mm flat roof rain water outlets	10	No.		
	<b>Testing and Commissioning</b>				
G	Allow for testing and commissioning of the rain water drainage installation to the satisfaction of the engineer.	1	Item		

COMMUNITY CENTRE

	<b>Total Cost For Rain Water Drainage Installation</b>	
--	--	--

ITEM	DESCRIPTION	AMOUNT (KES)
	<u><b>SUMMARY PAGE</b></u>	
1.0	<b>Total Cost for Internal Plumbing</b>	
2.0	<b>Total Cost for Roof + Riser</b>	
3.0	<b>Total Cost for Sanitary Fittings Install Only</b>	
4.0	<b>Total Cost Carried For hose reel and associated pipework Installations</b>	
5.0	<b>Total Cost For Portable fire Extinguishers + Hose Reel Pump Installation</b>	
6.0	<b>Total Cost For Ground Floor Foul Drainage Installation</b>	
7.0	<b>Total Cost For Rain Water Drainage Installation</b>	
	<b>Total carried to Mechanical Works Main Summary Page</b>	

GUARD HOUSE

ITEM	DESCRIPTION	QTY.	UNIT	RATE (KES)	AMOUNT (KES)
<b>1.0</b>	<b>GUARD HOUSE</b> <b><u>Internal Plumbing Installations</u></b>				
	Supply, deliver install, Test and Commission: PP-R (Polypropylene Random Co-polymer) pipes PN 20 and fittings with polyfusion welded joints to (KS ISO 15874 Part 1, 2, 3 & 5)of approved manufacturer. Rates must allow for all Metal/plastic threaded adaptors where required for the connection of sanitary fixtures, valves, sockets, sliding and fixed joints etc. as required in the running lengths of pipework. The pipes shall run in floors and wall chase. The pipes will be pressure tested before the plastering of wall commences and as per the manufacturers recommended testing pressures.				
	<b>Pipe Works</b>				
A	25mm Ø PPR Pipe	6	LM		
B	Ditto 20mm Ø	4	LM		
	<b>Extra Over Pipe Work</b>				
	<b>Elbows/ Bends</b>				
C	25mm Ø Elbows/ Bends	3	No.		
D	Ditto 20mm Ø	2	No.		
	<b>Equal/Unequal Tees</b>				
E	25 x 20 x 25mm	1	No.		
	<b>Reducers</b>				
F	25 x 20mm reducer	2	No.		
	<b>Male/Female brass threaded adaptor</b>				
G	25 x 20mm male/female threaded adaptor	2	No.		
H	25 x 15mm ditto	1	LM		
I	25 x 15mm male threaded bend	1	LM		
<b>Total Carried to Next Page</b>					

GUARD HOUSE

ITEM	DESCRIPTION	QTY.	UNIT	RATE (KES)	AMOUNT (KES)
	<b>Total from Previous Page</b>				
	<b>Isolating valves</b>				
J	25mm Ø Gate Valve as "Pegler" or Equivalent	1	No.		
	<b>Shut off Angle Valve</b>				
K	Brass plated 1/2" angle valve	3	No.		
	<b>Check Meter</b>				
L	25mm diameter water check meter	1	No.		
	<b>Testing and Commissioning</b>				
M	Allow for pressure testing of the Plumbing installation to the satisfaction of the Engineer including provision of necessary pipe plugs.	1	Item		
	<i>Sub Total for 1</i>				
	<b>TOTAL</b>	1		x 1	
<b>Total Cost of Plumbing Installation Guard House</b>					

GUARD HOUSE

ITEM	DESCRIPTION	QTY.	UNIT	RATE (KES)	AMOUNT (KES)
2.0	<b>SANITARY FITTINGS AND ACCESSORIES</b>				
A	<b>Water Closet (WC) Pan</b> Close Coupled dual flush Floor Standing Close Coupled WC Bowl complete with seat cover and cistern, WC connector relevant fittings & accessories	1	No.		
B	<b>Wash Basin</b> WHB basin Full pedestal Wash Basin 450x485x230m White Complte with bottle traps, flexible connection hoses and other accessories with cws only tap	1	No.		
C	<b>Shower Fittings</b> Shower fitting c/w 15mm diameter chrome plated stop cork, Instant shower fitting and 1/2" Cobra 211- 15 Star Pillar tap as Pegler or equal and equivalent	1	No.		
	<i>Sub Total for 1</i>				
	<b>TOTAL</b>	1		x 1	
<b>Total Cost of Sanitary Fittings &amp; Accessories</b>					



GUARD HOUSE

ITEM	DESCRIPTION	QTY.	UNIT	RATE (KES)	AMOUNT (KES)
	<p><b><u>Foul Drainage</u></b></p> <p>Supply, deliver and install the following in uPVC (Unplasticized Polyvinyl chloride) to (KS ISO 1452 Part 1, 2, 3, 4 &amp; 5) Heavy gauge soil and waste system. Allow for all the various sizes of adaptor, connectors, sockets, holderbats, clips etc not measured but required for the satisfactory functioning of the system.</p>				
	<p><b><u>Piping</u></b></p>				
A	32mm diameter heavy duty grey uPVC pipe	2	LM		
B	40mm ditto	3	LM		
C	50mm ditto	6	LM		
D	100mm ditto	4	LM		
E	100mm diameter heavy duty pipe	8	LM		
	<p><b><u>Extra over uPVC Pipeworks</u></b></p>				
F	32mm sweep bend	1	No.		
G	40mm sweep bend	1	No.		
H	50mm sweep bend	2	No.		
I	100mm sweep bend	1	No.		
J	40mm 45° bend	1	No.		
K	50mm Ditto	1	No.		
L	50mm sweep tee	2	No.		
M	40 x 32mm reducer	1	No.		
N	40mm access plug	1	No.		
<b>Total Carried to Next Page</b>					

GUARD HOUSE

ITEM	DESCRIPTION	QTY.	UNIT	RATE (KES)	AMOUNT (KES)
	<b>Total From Previous Page</b>				
AA	100 x 50mm floor trap set complete with plastic flush grating	2	No.		
	<b>Gulley Trap</b> Gully trap comprising of 100mm diameter golden brown uPVC gully piece, 100mm diameter uPVC trap spigot outlet with screws and washers, and 300 x 300mm masonry gully trap chamber with mild steel plate and a heavy duty iron cover.	1	No.		
	<b>Manholes</b> Construct manhole/ inspection chamber size 450 x 600 x 750mm deep internally in 200mm stone walls, 150mm concrete bed, water proof plaster, forming drain channels, medium duty cover frame in cast iron with recessed cover with concrete infill and all necessary formwork, excavation and soil disposal.	1	No.		
	<b>Excavations</b> Excavate trench for pipe not exceeding 100mm diameter and not exceeding 1.5m deep (average 600mm deep) and make good as before.	8	LM		
	Allow for hydrostatic pressure testing of drainage installation including provision of pipe plugs and other required fittings.	1	Item		
	<b>Total Cost For Ground Floor Foul Drainage Installation</b>				

GUARD HOUSE

ITEM	DESCRIPTION	QTY.	UNIT	RATE (KES)	AMOUNT (KES)
	<p><b>Rain Water Drainage</b></p> <p>Supply, deliver and install UPVC (Unplasticized Polyvinyl chloride) to (KS ISO 1452 Part 1, 2, 3, 4 &amp; 5) rainwater pipework. Allow for all flanges, couplings, nipples, connector joints, fixing clips holder bats etc as required in running length of pipework but not measured.</p> <p><b>Piping</b></p> <p><b>A</b> 100mm ditto</p> <p>Extra over piping for fittings:-</p> <p><b>B</b> 100mm ditto</p> <p><b>C</b> 100mm sweep bend</p> <p><b>D</b> 100mm single branch</p> <p><b>E</b> 100mm double branch</p> <p><b>F</b> 100mm flat roof rain water outlets</p>	<p>6</p> <p>2</p> <p>2</p> <p>2</p> <p>2</p> <p>1</p>	<p>LM</p> <p>No.</p> <p>No.</p> <p>No.</p> <p>No.</p> <p>No.</p>		
	<b>Total Cost For Rain Water Drainage Installation</b>				

# GUARD HOUSE

GUARD HOUSE

ITEM	DESCRIPTION	QTY.	UNIT	RATE (KES)	AMOUNT (KES)
A	<p><b>ROOF WATER STORAGE TANK</b></p> <p>Top Tank Deluxe heavy duty rotationally moulded polyethylene cylindrical vertical close end tank of nominal capacity of 1000 Litres and complete with lid and ball valve, float switch. Tanks to be complete with inlet, outlet and overflow connections and tank connectors for the same as described below: -</p> <ul style="list-style-type: none"> <li>- 1 No. 32mm diameter inlet pipe connection</li> <li>- 1 No. 50mm diameter outlet pipe connection</li> <li>- 1 No. 40 mm diameter overflow pipe connection</li> </ul> <p>Tank Capacity : 1000 litres</p>	1	No		
<b>Total Cost For Roof Tanks</b>					

GUARD HOUSE

ITEM	DESCRIPTION	AMOUNT (KES)
<u>SUMMARY PAGE</u>		
1.0	Total Cost for Internal Plumbing	
3.0	Total Cost for Sanitary Fittings	
6.0	Total Cost For Ground Floor Foul Drainage Installation	
8.0	Total Cost For Rain Water Drainage Installation	
9.0	Total Cost For Roof Tanks	
<b>Total carried to Mechanical Works Main Summary Page</b>		

GARBAGE RECEPTACLE

ITEM	DESCRIPTION	QTY.	UNIT	RATE (KES)	AMOUNT (KES)
	<b>GARBAGE RECEPTACLE</b>				
<b>1.0</b>	<b><u>Internal Plumbing Installations</u></b>				
	Supply, deliver install, Test and Commission: PP-R (Polypropylene Random Co-polymer) pipes PN 20 and fittings with polyfusion welded joints to (KS ISO 15874 Part 1, 2, 3 & 5) of approved manufacturer. Rates must allow for all Metal/plastic threaded adaptors where required for the connection of sanitary fixtures, valves, sockets, sliding and fixed joints etc. as required in the running lengths of pipework. The pipes shall run in floors and wall chase. The pipes will be pressure tested before the plastering of wall commences and as per the manufacturers recommended testing pressures.				
	<b>Pipe Works</b>				
A	25mm Ø PPR Pipe	2	LM		
B	Ditto 20mm Ø	2	LM		
	<b>Extra Over Pipe Work</b>				
	<b>Elbows/ Bends</b>				
C	25mm Ø Elbows/ Bends	3	No.		
D	Ditto 20mm Ø	2	No.		
	<b>Equal/Unequal Tees</b>				
E	25 x 20 x 25mm	1	No.		
	<b>Reducers</b>				
F	25 x 20mm reducer	2	No.		
	<b>Male/Female brass threaded adaptor</b>				
G	25 x 20mm male/female threaded adaptor	2	No.		
H	25 x 15mm ditto	1	LM		
I	25 x 15mm male threaded bend	1	LM		
<b>Total Carried to Next Page</b>					

GARBAGE RECEPTACLE

ITEM	DESCRIPTION	QTY.	UNIT	RATE (KES)	AMOUNT (KES)
	<b>Total from Previous Page</b>				
	<b>Isolating valves</b>				
J	25mm Ø Gate Valve as "Pegler" or Equivalent	1	No.		
	<b>Testing and Commissioning</b>				
L	Allow for pressure testing of the Plumbing installation to the satisfaction of the Engineer including provision of necessary pipe plugs.	1	Item		
	<i>Sub Total</i>				
	<b>TOTAL</b>	1		x 1	
<b>Total Cost of Plumbing Installation Guard House</b>					



GARBAGE RECEPTACLE

ITEM	DESCRIPTION	QTY.	UNIT	RATE (KES)	AMOUNT (KES)
	<p><b><u>Foul Drainage</u></b></p> <p>Supply, deliver and install the following in uPVC (Unplasticized Polyvinyl chloride) to (KS ISO 1452 Part 1, 2, 3, 4 &amp; 5) Heavy gauge soil and waste system. Allow for all the various sizes of adaptor, connectors, sockets, holderbats, clips etc not measured but required for the satisfactory functioning of the system.</p>				
	<p><b><u>Piping</u></b></p>				
A	50mm ditto	6	LM		
B	100mm ditto	4	LM		
C	100mm diameter heavy duty pipe	4	LM		
	<p><b>Extra over uPVC Pipeworks</b></p>				
D	50mm sweep bend	2	No.		
E	100mm sweep bend	1	No.		
<b>Total Carried to Next Page</b>					

GARBAGE RECEPTACLE

ITEM	DESCRIPTION	QTY.	UNIT	RATE (KES)	AMOUNT (KES)
	<b>Total From Previous Page</b>				
EE	<b>Gulley Trap</b> Gully trap comprising of 100mm diameter golden brown uPVC gully piece, 100mm diameter uPVC trap spigot outlet with screws and washers, and 300 x 300mm masonry gully trap chamber with mild steel plate and a heavy	1	No.		
GG	<b>Manholes</b> Construct manhole/ inspection chamber size 450 x 600 x 750mm deep internally in 200mm stone walls, 150mm concrete bed, water proof plaster, forming drain channels, medium duty cover frame in cast iron with recessed cover with concrete infill and all necessary formwork, excavation and soil disposal.	1	No.		
HH	<b>Excavations</b> Excavate trench for pipe not exceeding 100mm diameter and not exceeding 1.5m deep (average 600mm deep) and make good as before.	4	LM		
	<b>Total Cost For Ground Floor Foul Drainage Installation</b>				

GARBAGE RECEPTACLE

ITEM	DESCRIPTION	QTY.	UNIT	RATE (KES)	AMOUNT (KES)
	<p><b>Rain Water Drainage</b></p> <p>Supply, deliver and install UPVC rainwater pipes and PPR pipework. Allow for all flanges, couplings, nipples, connector joints, fixing clips holder bats etc as required in running length of pipework but not measured.</p> <p><b>Piping</b></p> <p><b>A</b> 100mm ditto</p> <p>Extra over piping for fittings:-</p> <p><b>B</b> 100mm ditto</p> <p><b>C</b> 100mm sweep bend</p> <p><b>D</b> 100mm single branch</p> <p><b>E</b> 100mm double branch</p> <p><b>F</b> 100mm flat roof rain water outlets</p>	<p>6</p> <p>2</p> <p>2</p> <p>2</p> <p>2</p> <p>1</p>	<p>LM</p> <p>No.</p> <p>No.</p> <p>No.</p> <p>No.</p> <p>No.</p>		
	<b>Total Cost For Rain Water Drainage Installation</b>				

GARBAGE RECEPTACLE

ITEM	DESCRIPTION	QTY.	UNIT	RATE (KES)	AMOUNT (KES)
A	<p><b>ROOF WATER STORAGE TANK</b></p> <p>Top Tank Deluxe heavy duty rotationally moulded polyethylene cylindrical vertical close end tank of nominal capacity of 1000 Litres and complete with lid and ball valve, float switch. Tanks to be complete with inlet, outlet and overflow connections and tank connectors for the same as described below: -</p> <ul style="list-style-type: none"> <li>- 1 No. 32mm diameter inlet pipe connection</li> <li>- 1 No. 50mm diameter outlet pipe connection</li> <li>- 1 No. 40 mm diameter overflow pipe connection</li> </ul> <p>Tank Capacity : 500 litres</p>	1	No		
<b>Total Cost For Roof Tanks</b>					

GARBAGE RECEPTACLE

ITEM	DESCRIPTION	AMOUNT (KES)
<u>SUMMARY PAGE</u>		
1.0	Total Cost for Internal Plumbing	
2.0	Total Cost For Ground Floor Foul Drainage Installation	
3.0	Total Cost For Rain Water Drainage Installation	
4.0	Total Cost For Roof Tanks	
<b>Total carried to Mechanical Works Main Summary Page</b>		

**BUNGOMA GRAND SUMMARY PAGE**

ITEM	DESCRIPTION	Unit	Qty	RATE (KSHS)	AMOUNT (KSHS)
1	SUMMARY FOR MECHANICAL SERVICES FOR AFFORDABLE HOUSING BLOCK TYPE A	No	9		
2	SUMMARY FOR MECHANICAL SERVICES FOR AFFORDABLE HOUSING BLOCK TYPE B	No	8		
3	SUMMARY FOR EXTERNAL RETICULATION	No	1		
4	SUMMARY FOR MECHANICAL SERVICES FOR CLUB HOUSE	No	1		
5	SUMMARY FOR MECHANICAL INSTALLATION SCHOOL	No	1		
6	SUMMARY FOR MECHANICAL SERVICES FOR MARKET	No	1		
7	SUMMARY FOR MECHANICAL SERVICES FOR COMMUNITY CENTRE BUILDING	No	1		
8	SUMMARY FOR MECHANICAL SERVICES FOR GUARD HOUSE	No	5		
9	SUMMARY FOR MECHANICAL SERVICES FOR GARBAGE RECEPTACLE	No	6		
	TOTALS FOR MECHANICAL INSTALLATION SERVICES FOR PROPOSED BUNGOMA AFFORDABLE HOUSING PROJECT				

--	--

Amount in Words: Kenya Shillings.....

.....  
 .....

Official Stamp & Address:.....

.....  
 .....

Tenderer's Signature:.....Date:.....

Witness' Name:.....Witness' Signature:.....

Address:.....

Date:.....

ITEM	DESCRIPTION	UNIT	QTY	RATE	AMOUNT
A	<p style="text-align: center;"><b>MECHANICAL INSTALLATIONS</b></p> <p>TOTALS FOR MECHANICAL INSTALLATION SERVICES (Brought forward from Mechanical Works BoQ)</p> <p><b><u>NB:</u></b> <i>Omissions/Exclusions as indicated on the Summary Page moved to Main Works Provisional Sums</i></p>	SUM	1		
	<b>TOTAL FOR MECHANICAL INSTALLATIONS CARRIED TO GRAND SUMMARY</b>				

# **ELECTRICAL INSTALLATION WORKS**



ITEM	DESCRIPTION	UNIT	QTY	RATE (KSH)	AMOUNT (KSH)
	<b><u>BILL NO. 1</u></b>				
	<b><u>PROPOSED TYPICAL SOCIAL &amp; AFFORDABLE UNITS BLOCK TYPE A</u></b>				
	<b>(i) <u>GROUND FLOOR</u></b>				
	<b>A. <u>2 BEDROOM AHP UNITS</u></b>				
	SUPPLY, DELIVER , INSTALL ,SET TO WORK AND COMMISSION THE FOLLOWING:-				
	<b>LIGHTING POINTS</b>				
1.01	Lighting point completely wired in 3 x 1.5mm <sup>2</sup> single core PVC insulated copper cables drawn in 20mm diameter heavy gauge PVC conduits including all accessories for one way switching, but excluding the switch and luminaire.	No.	6		
	ii) Ditto as in item No. 1.01 but for two way switching	No.	4		
1.02	10A white moulded switch plate as Crabtree, MK Logic, Clipsal E- Series or approved equivalent as follows:-				
	i) 10A one gang one way switch	No.	3		
	ii) 10A one gang two way switch	No.	5		
	iii) 10A two gang two way switch	No.	2		
1.03	<b>LIGHTING FITTINGS</b>				
	a) Ceiling rose complete with 3 core flex cable, lamp holder and 11W led lamp as crabtree or approved equivalent <b>Type 'CR'</b>	No.	6		
	b) Spherical screwneck luminaire with opal glass and 16W compact fluorescent lamp as Astra, Micromark, Thorn or approved equivalent. <b>"Type BF"</b>	No.	2		
	<b>Total Carried Forward to the Next Pg.</b>				

ITEM	DESCRIPTION	UNIT	QTY	RATE (KSH)	AMOUNT (KSH)
	<b>Total B/F from Previous Pg.</b>				
	<b>POWER AND SOCKET OUTLET POINTS</b>				
1.04	13A SP socket point completely wired in 3 x 2.5mm <sup>2</sup> single core PVC insulated copper cables drawn in 25mm diameter heavy gauge PVC conduits including all accessories but excluding the 13A SP switched socket outlet.	No.	7		
1.05	Socket Outlet plates i) 13A SP twin switched socket outlet as MK 2536 or approved equivalent.	No.	7		
1.06	Instant shower water heater power points completely wired in 3 x 4mm <sup>2</sup> single core PVC insulated copper cables drawn in 25mm diameter heavy gauge PVC conduits including all accessories, but excluding the 40A DP connection unit	No.	1		
1.07	40A DP switched connection unit with neon indicator as MK or approved equivalent	No.	1		
1.08	Cooker outlet power points completely wired in 3 x 6.0mm <sup>2</sup> single core PVC insulated copper cables drawn in 32mm diameter heavy gauge PVC conduits including all accessories, but excluding the 45A Cooker connection unit	No.	1		
1.09	45A Moulded plate Cooker Control Unit complete with 13A fused Socket outlet as MK/Crabtree or approved equivalent.	No.	1		
1.10	45A moulded plate cooker connection unit as MK/Crabtree or approved equivalent:	No.	1		
	<b>Total Carried Forward to the Next Pg.</b>				

ITEM	DESCRIPTION	UNIT	QTY	RATE (KSH)	AMOUNT (KSH)
	<b>Total B/F from Previous Pg.</b>				
1.11	Domestic door bell point completely wired in 3 x 1.5mm <sup>2</sup> single core PVC insulated copper cables drawn in 20mm diameter heavy gauge PVC conduits including all accessories but excluding the bell.	No.	1		
1.12	240V/12V Ding dong domestic door bell	No.	1		
	<b>TELEPHONE, DATA AND TV POINTS POINTS</b>				
1.13	Data point comprising of draw wire in 25mm diameter Heavy Gauge PVC conduits including all accessories and blanking cover but excluding the Data socket outlet.	No.	1		
1.14	DTV Socket point comprising of draw wire in 25mm diameter Heavy Gauge PVC conduits including all accessories and blanking cover but excluding the DTV socket outlet.	No.	1		
1.15	300x 300x 100mm deep 16G galvanized adaptable	No.	2		
1.16	25mm diameter PVC HG conduit for ICT services and linking the Draw Boxes to the ICT ducts	LM	45		
<b>Total Carried Forward to the Next Pg.</b>					

ITEM	DESCRIPTION	UNIT	QTY	RATE (KSH)	AMOUNT (KSH)
	<b>Total B/F from Previous Pg.</b>				
	<b>POWER RETICULATION AND DISTRIBUTION BOARDS</b>				
1.17	6 ways 100A SPN Consumer Unit 'A' complete with 100A SPN integral isolator, but excluding the MCBs ,and as Schneider Electric Acti 9 or approved equivalent.	No.	1		
1.18	<b>MCBs for item above as Schneider Electric Acti 9</b>				
	i)10 A SP MCB	No.	1		
	ii)32 A SP MCB	No.	2		
	iii) 45 A SP MCB	No.	1		
	iv) Blanking plates	No.	2		
1.19	Sub-mains circuits for CU 'A ' above comprising of 3 x 10mm <sup>2</sup> single core PVC insulated copper cables drawn in 32mm heavy gauge conduits and running from the LV switchboard below the staircase.	LM	45		
<b>Total Carried Forward to Ground Floor Collection Pg.</b>					

ITEM	DESCRIPTION	UNIT	QTY	RATE (KSH)	AMOUNT (KSH)
<b>B.</b>	<b><u>3 BEDROOM AHP UNIT</u></b>				
	SUPPLY, DELIVER , INSTALL ,SET TO WORK AND COMMISSION THE FOLLOWING:-				
	<b>LIGHTING POINTS</b>				
1.01	Lighting point completely wired in 3 x 1.5mm <sup>2</sup> single core PVC insulated copper cables drawn in 20mm diameter heavy gauge PVC conduits including all accessories for one way switching, but excluding the switch and luminaire.	No.	4		
	ii) Ditto as in item No. 1.01 but for two way switching	No.	6		
1.02	10A white moulded switch plate as Crabtree, MK Logic, Clipsal E- Series or approved equivalent as follows:-				
	i) 10A one gang one way switch	No.	4		
	ii) 10A one gang two way switch	No.	8		
	iii) 10A two gang two way switch	No.	1		
1.03	<b>LIGHTING FITTINGS</b>				
	a) Ceiling rose complete with 3 core flex cable, lamp holder and 11W led lamp as crabtree or approved equivalent <b>Type 'CR'</b>	No.	7		
	b) Spherical screwneck luminaire with opal glass and 16W compact fluorescent lamp as Astra, Micromark, Thorn or approved equivalent. <b>"Type BF"</b>	No.	3		
<b>Total Carried Forward to the Next Pg.</b>					

ITEM	DESCRIPTION	UNIT	QTY	RATE (KSH)	AMOUNT (KSH)
	<b>Total B/F from Previous Pg.</b>				
	<b>POWER AND SOCKET OUTLET POINTS</b>				
1.04	13A SP socket point completely wired in 3 x 2.5mm <sup>2</sup> single core PVC insulated copper cables drawn in 25mm diameter heavy gauge PVC conduits including all accessories but excluding the 13A SP switched socket outlet.	No.	8		
1.05	Socket Outlet plates i) 13A SP twin switched socket outlet as MK 2536 or equal & approved equivalent.	No.	8		
1.06	Instant shower water heater power points completely wired in 3 x 4mm <sup>2</sup> single core PVC insulated copper cables drawn in 25mm diameter heavy gauge PVC conduits including all accessories, but excluding the 40A DP connection unit	No.	2		
1.07	40A DP switched connection unit with neon indicator as MK or approved equivalent	No.	2		
1.08	Cooker outlet power points completely wired in 3 x 6.0mm <sup>2</sup> single core PVC insulated copper cables drawn in 32mm diameter heavy gauge PVC conduits including all accessories, but excluding the 45A DP connection unit	No.	1		
1.09	45A Moulded plate Cooker Control Unit complete with 13A fused socket outlet as MK/Crabtree or approved equivalent.	No.	1		
1.10	45A Moulded plate Cooker Control Unit complete with 13A fused Socket outlet as MK/Crabtree or approved equivalent.	No.	1		
	<b>Total Carried Forward to the Next Pg.</b>				

ITEM	DESCRIPTION	UNIT	QTY	RATE (KSH)	AMOUNT (KSH)
	<b>Total B/F from Previous Pg.</b>				
1.11	Domestic door bell point completely wired in 3 x 1.5mm <sup>2</sup> single core PVC insulated copper cables drawn in 20mm diameter heavy gauge PVC conduits including all accessories but excluding the bell.	No.	1		
1.12	240V/12V Ding dong domestic door bell	No.	1		
	<b>TELEPHONE, DATA AND TV POINTS POINTS</b>				
1.13	Data point comprising of draw wire in 25mm diameter Heavy Gauge PVC conduits including all accessories and blanking cover but excluding the telephone socket outlet.	No.	1		
1.14	DTV Socket point comprising of draw wire in 25mm diameter Heavy Gauge PVC conduits including all accessories and blanking cover but excluding the DTV socket outlet.	No.	1		
1.15	300x 300x 100mm deep 16G galvanized adaptable box.	No.	2		
1.16	25mm diameter PVC HG conduit for ICT services and linking the Draw Boxes to the ICT ducts	LM	45		
<b>Total Carried Forward to the Next Pg.</b>					

ITEM	DESCRIPTION	UNIT	QTY	RATE (KSH)	AMOUNT (KSH)
	<b>Total B/F from Previous Pg.</b>				
	<b>POWER RETICULATION AND DISTRIBUTION BOARDS</b>				
1.17	6 ways 100A SPN Consumer Unit `A' complete with 100A SPN integral isolator ,but excluding the MCBs, and as Schneider Electric Acti 9 or approved equivalent.	No.	1		
1.18	<b>MCBs for item above as Schneider Electric Acti 9</b>				
	i)10 A SP MCB	No.	1		
	ii)32 A SP MCB	No.	3		
	iii) 45 A SP MCB	No.	1		
	iv) Blanking plates	No.	1		
1.19	Sub-mains circuits for CU 'A ' above comprising of 3 x 10mm <sup>2</sup> single core PVC insulated copper cables drawn in 32mm heavy gauge conduits and running from the Lv switchboard below the staircase.	LM	45		
<b>Total Carried Forward to the Ground Floor Collection Pg.</b>					



ITEM	DESCRIPTION	UNIT	QTY	RATE (KSH)	AMOUNT (KSH)
C.	<b><u>STUDIO SOCIAL UNITS</u></b>				
	SUPPLY, DELIVER , INSTALL ,SET TO WORK AND COMMISSION THE FOLLOWING:-				
	<b>LIGHTING POINTS</b>				
1.01	Lighting point completely wired in 3 x 1.5mm <sup>2</sup> single core PVC insulated copper cables drawn in 20mm diameter heavy gauge PVC conduits including all accessories for one way switching, but excluding the switch and luminaire.	No.	1		
	ii) Ditto as in item No. 1.01 but for two way switching	No.	2		
1.02	10A white moulded switch plate as Crabtree, MK Logic, Clipsal E- Series or approved equivalent as follows:-				
	i) 10A one gang one way switch	No.	1		
	ii) 10A one gang two way switch	No.	2		
	iii) 10A two gang two way switch	No.	1		
1.03	<b>LIGHTING FITTINGS</b>				
	a) Ceiling rose complete with 3 core flex cable, lamp holder and 11W led lamp as crabtree or approved equivalent <b>Type 'CR'</b>	No.	2		
	b) Spherical screwneck luminaire with opal glass and 16W compact fluorescent lamp as Astra, Micromark, Thorn or approved equivalent. <b>"Type BF"</b>	No.	1		
<b>Total Carried Forward to the Next Pg.</b>					

ITEM	DESCRIPTION	UNIT	QTY	RATE (KSH)	AMOUNT (KSH)
	<b>Total B/F from Previous Pg.</b>				
	<b>POWER AND SOCKET OUTLET POINTS</b>				
1.04	13A SP socket point completely wired in 3 x 2.5mm <sup>2</sup> single core PVC insulated copper cables drawn in 25mm diameter heavy gauge PVC conduits including all accessories but excluding the 13A SP switched socket outlet.	No.	4		
1.05	Socket Outlet plates i) 13A SP twin switched socket outlet as MK 2536 or equal & approved equivalent.	No.	4		
1.06	Instant shower water heater power points completely wired in 3 x 4mm <sup>2</sup> single core PVC insulated copper cables drawn in 25mm diameter heavy gauge PVC conduits including all accessories ,but excluding the 40A DP connection unit	No.	1		
1.07	40A DP switched connection unit with neon indicator as MK or approved equivalent	No.	1		
1.08	Cooker outlet power points completely wired in 3 x 6.0mm <sup>2</sup> single core PVC insulated copper cables drawn in 32mm diameter heavy gauge PVC conduits including all accessories ,but excluding the 45A DP connection unit	No.	1		
1.09	45A Moulded plate Cooker Control Unit complete with 13A fused Socket outlet as MK/Crabtree or approved equivalent.	No.	1		
1.10	45A moulded plate cooker connection unit as MK/Crabtree or approved equivalent:	No.	1		
	<b>Total Carried Forward to the Next Pg.</b>				

ITEM	DESCRIPTION	UNIT	QTY	RATE (KSH)	AMOUNT (KSH)
	<b>Total B/F from Previous Pg.</b>				
1.11	Domestic door bell point completely wired in 3 x 1.5mm <sup>2</sup> single core PVC insulated copper cables drawn in 20mm diameter heavy gauge PVC conduits including all accessories but excluding the bell.	No.	1		
1.12	240V/12V Ding dong domestic door bell	No.	1		
	<b>TELEPHONE, DATA AND TV POINTS POINTS</b>				
1.13	Data point comprising of draw wire in 25mm diameter Heavy Gauge PVC conduits including all accessories and blanking plate but excluding the telephone socket outlet.	No.	1		
1.14	DTV Socket point comprising of draw wire in 25mm diameter Heavy Gauge PVC conduits including all accessories but excluding the DTV socket outlet.	No.	1		
1.15	300x 300x 100mm deep 16G galvanized adaptable box.	No.	2		
1.16	25mm diameter PVC HG conduit for ICT services and linking the Draw Boxes to the ICT ducts	LM	30		
	<b>Total Carried Forward to the Next Pg.</b>				

ITEM	DESCRIPTION	UNIT	QTY	RATE (KSH)	AMOUNT (KSH)
	<b>Total B/F from Previous Pg.</b>				
	<b>POWER RETICULATION AND DISTRIBUTION BOARDS</b>				
1.17	6 ways 100A SPN Consumer Unit 'A' complete with 100A SPN integral isolator ,but excluding the MCBs ,and as Schneider Electric Acti 9 or approved equivalent.	No.	1		
1.18	<b>MCBs for item above as Schneider Electric Acti 9 or approved equivalent</b>				
	i)10 A SP MCB	No.	1		
	ii)32 A SP MCB	No.	3		
	iii) 45 A SP MCB	No.	1		
	iv) Blanking plates	No.	1		
1.19	Sub-mains circuits for CU 'A ' above comprising of 3 x 10mm <sup>2</sup> single core PVC insulated copper cables drawn in 32mm heavy gauge conduits and running from the LV switchboard below the staircase.	LM	30		
<b>Total Carried Forward to the Next Pg.</b>					

ITEM	DESCRIPTION	UNIT	QTY	RATE (KSH)	AMOUNT (KSH)
<b>D.</b>	<b><u>2 ROOM/1 ROOM UNITS</u></b>				
	SUPPLY, DELIVER , INSTALL ,SET TO WORK AND COMMISSION THE FOLLOWING:-				
	<b>LIGHTING POINTS</b>				
1.01	Lighting point completely wired in 3 x 1.5mm <sup>2</sup> single core PVC insulated copper cables drawn in 20mm diameter heavy gauge PVC conduits including all accessories for one way switching, but excluding the switch and luminaire.	No.	2		
	ii) Ditto as in item No. 1.01 but for two way switching	No.	3		
1.02	10A white moulded switch plate as Crabtree, MK Logic, Clipsal E- Series or approved equivalent as follows:-				
	i) 10A two gang one way switch	No.	1		
	ii) 10A one gang two way switch	No.	3		
	iii) 10A two gang two way switch	No.	1		
1.03	<b>LIGHTING FITTINGS</b>				
	a) Ceiling rose complete with 3 core flex cable, lamp holder and 11W led lamp as crabtree or approved equivalent <b>Type 'CR'</b>	No.	4		
	b) Spherical screwneck luminaire with opal glass and 16W compact fluorescent lamp as Astra, Micromark, Thorn or approved equivalent. <b>"Type BF"</b>	No.	1		
<b>Total Carried Forward to the Next Pg.</b>					

ITEM	DESCRIPTION	UNIT	QTY	RATE (KSH)	AMOUNT (KSH)
	<b>Total B/F from Previous Pg.</b>				
	<b>POWER AND SOCKET OUTLET POINTS</b>				
1.04	13A SP socket point completely wired in 3 x 2.5mm <sup>2</sup> single core PVC insulated copper cables drawn in 25mm diameter heavy gauge PVC conduits including all accessories but excluding the 13A SP switched socket outlet.	No.	6		
1.05	Socket Outlet plates i) 13A SP twin switched socket outlet as MK 2536 or equal & approved equivalent.	No.	6		
1.06	Instant shower water heater power points completely wired in 3 x 4mm <sup>2</sup> single core PVC insulated copper cables drawn in 25mm diameter heavy gauge PVC conduits including all accessories, but excluding the 40A DP connection unit	No.	1		
1.07	40A DP switched connection unit with neon indicator as MK or approved equivalent	No.	1		
1.08	Cooker outlet power points completely wired in 3 x 6.0mm <sup>2</sup> single core PVC insulated copper cables drawn in 32mm diameter heavy gauge PVC conduits including all accessories ,but excluding the 45A DP connection unit	No.	1		
1.09	45A Moulded plate Cooker Control Unit complete with 13A fused socket outlet as MK/Crabtree or approved equivalent.	No.	1		
1.10	45A moulded plate cooker connection unit as MK/Crabtree or approved equivalent:	No.	1		
	<b>Total Carried Forward to the Next Pg.</b>				

ITEM	DESCRIPTION	UNIT	QTY	RATE (KSH)	AMOUNT (KSH)
	<b>Total B/F from Previous Pg.</b>				
1.11	Domestic door bell point completely wired in 3 x 1.5mm <sup>2</sup> single core PVC insulated copper cables drawn in 20mm diameter heavy gauge PVC conduits including all accessories but excluding the bell.	No.	1		
1.12	240V/12V Ding dong domestic door bell	No.	1		
	<b>TELEPHONE, DATA AND TV POINTS POINTS</b>				
1.13	Data point comprising of draw wire in 25mm diameter Heavy Gauge PVC conduits including all accessories and blanking plate but excluding the data socket outlet.	No.	1		
1.14	DTV Socket point comprising of draw wire in 25mm diameter Heavy Gauge PVC conduits including all accessories but excluding the DTV socket outlet.	No.	1		
1.15	300x 300x 100mm deep 16G galvanized adaptable box.	No.	2		
1.16	25mm diameter PVC HG conduit for ICT services and linking the Draw Boxes to the ICT ducts	LM	20		
	<b>Total Carried Forward to the Next Pg.</b>				

ITEM	DESCRIPTION	UNIT	QTY	RATE (KSH)	AMOUNT (KSH)
	<b>Total B/F from Previous Pg.</b>				
	<b>POWER RETICULATION AND DISTRIBUTION BOARDS</b>				
1.17	6 ways 100A SPN Consumer Unit 'A' complete with 100A SPN integral isolator, but excluding the MCBs ,and as Schneider Electric Acti 9 or approved equivalent.	No.	1		
1.18	<b>MCBs for item above as Schneider Electric Acti 9 or approved equivalent</b>				
	i)10 A SP MCB	No.	1		
	ii)32 A SP MCB	No.	3		
	iii) 45 A SP MCB	No.	1		
	iv) Blanking plates	No.	1		
1.19	Sub-mains circuits for CU 'A ' above comprising of 3 x 10mm <sup>2</sup> single core PVC insulated copper cables drawn in 32mm heavy gauge conduits and running from the LVswitchboard below the staircase.	LM	20		
<b>Total Carried Forward to Ground Floor Collection Pg.</b>					



ITEM	DESCRIPTION	UNIT	QTY	RATE (KSH)	AMOUNT (KSH)
E.	<b><u>3 ROOM SOCIAL UNIT</u></b>				
	SUPPLY, DELIVER , INSTALL ,SET TO WORK AND COMMISSION THE FOLLOWING:-				
	<b>LIGHTING POINTS</b>				
1.01	Lighting point completely wired in 3 x 1.5mm <sup>2</sup> single core PVC insulated copper cables drawn in 20mm diameter heavy gauge PVC conduits including all accessories for one way switching, but excluding the switch and luminaire.	No.	2		
	ii) Ditto as in item No. 1.01 but for two way switching	No.	5		
1.02	10A white moulded switch plate as Crabtree, MK Logic, Clipsal E- Series or approved equivalent as follows:-				
	i) 10A one gang one way switch	No.	1		
	ii) 10A one gang two way switch	No.	4		
	iii) 10A two gang two way switch	No.	3		
1.03	<b>LIGHTING FITTINGS</b>				
	a) Ceiling rose complete with 3 core flex cable, lamp holder and 11W led lamp as crabtree or approved equivalent <b>Type 'CR'</b>	No.	6		
	b) Spherical screwneck luminaire with opal glass	No.	1		
<b>Total Carried Forward to the Next Pg.</b>					

ITEM	DESCRIPTION	UNIT	QTY	RATE (KSH)	AMOUNT (KSH)
	<b>Total B/F from Previous Pg.</b>				
	<b>POWER AND SOCKET OUTLET POINTS</b>				
1.04	13A SP socket point completely wired in 3 x 2.5mm <sup>2</sup> single core PVC insulated copper cables drawn in 25mm diameter heavy gauge PVC conduits including all accessories but excluding the 13A SP switched socket outlet.	No.	7		
1.05	Socket Outlet plates i) 13A SP twin switched socket outlet as MK 2536 or equal & approved equivalent.	No.	7		
1.06	Instant shower water heater power points completely wired in 3 x 4mm <sup>2</sup> single core PVC insulated copper cables drawn in 25mm diameter heavy gauge PVC conduits including all accessories, but excluding the 40A DP connection unit	No.	1		
1.07	40A DP switched connection unit with neon indicator as MK or approved equivalent	No.	1		
1.08	Cooker outlet power points completely wired in 3 x 6.0mm <sup>2</sup> single core PVC insulated copper cables drawn in 32mm diameter heavy gauge PVC conduits including all accessories, but excluding the 45A DP connection unit	No.	1		
1.09	45A Moulded plate Cooker Control Unit complete with 13A fused socket outlet as MK/Crabtree or approved equivalent.	No.	1		
1.10	45A Moulded plate Cooker Control Unit complete with 13A fused Socket outlet as MK/Crabtree or approved equivalent.	No.	1		
	<b>Total Carried Forward to the Next Pg.</b>				

ITEM	DESCRIPTION	UNIT	QTY	RATE (KSH)	AMOUNT (KSH)
	<b>Total B/F from Previous Pg.</b>				
1.11	Domestic door bell point completely wired in 3 x 1.5mm <sup>2</sup> single core PVC insulated copper cables drawn in 20mm diameter heavy gauge PVC conduits including all accessories but excluding the bell.	No.	1		
1.12	240V/12V Ding dong domestic door bell	No.	1		
	<b>TELEPHONE, DATA AND TV POINTS POINTS</b>				
1.13	Data point comprising of draw wire in 25mm diameter Heavy Gauge PVC conduits including all accessories and blanking cover but excluding the telephone socket outlet.	No.	1		
1.14	DTV Socket point comprising of draw wire in 25mm diameter Heavy Gauge PVC conduits including all accessories and blanking cover but excluding the DTV socket outlet.	No.	1		
1.15	300x 300x 100mm deep 16G galvanized adaptable box.	No.	2		
1.16	25mm diameter PVC HG conduit for ICT services and linking the Draw Boxes to the ICT ducts	Lm.	20		
	<b>Total Carried Forward to the Next Pg.</b>				

ITEM	DESCRIPTION	UNIT	QTY	RATE (KSH)	AMOUNT (KSH)
	<b>Total B/F from Previous Pg.</b>				
	<b>POWER RETICULATION AND DISTRIBUTION BOARDS</b>				
1.17	6 ways 100A SPN Consumer Unit 'A' complete with 100A SPN integral isolator ,but excluding the MCBs, and as Schneider Electric Acti 9 or approved equivalent.	No.	1		
1.18	<b>MCBs for item above as Schneider Electric Acti 9</b>				
	i)10 A SP MCB	No.	1		
	ii)32 A SP MCB	No.	3		
	iii) 45 A SP MCB	No.	1		
	iv) Blanking plates	No.	1		
1.19	Sub-mains circuits for CU 'A ' above comprising of 3 x 10mm <sup>2</sup> single core PVC insulated copper cables drawn in 32mm heavy gauge conduits and running from the Lv switchboard below the staircase.	LM	20		
<b>Total Carried Forward to Ground Floor Collection Page</b>					

ITEM	DESCRIPTION	UNIT	QTY	RATE (KSH)	AMOUNT (KSH)
F.	<b><u>CORRIDOR/LIFTS LOBBY AREA</u></b>				
	SUPPLY, DELIVER , INSTALL ,SET TO WORK AND COMMISSION THE FOLLOWING:-				
	<b>LIGHTING POINTS</b>				
1.01	Lighting point completely wired in 3 x 1.5mm <sup>2</sup> single core PVC insulated copper cables drawn in 20mm diameter heavy gauge PVC conduits including all accessories for two way switching, but excluding the switch and luminaire.	No.	31		
1.02	10A white moulded switch plate as Crabtree, MK Logic, Clipsal E- Series or approved equivalent as follows:-				
	i) 10A one gang two way switch	No.	4		
	ii) 10A two gang two way switch	No.	4		
1.03	<b>LIGHTING FITTINGS</b>				
	a) Circular shaped surface mounted led luminaire	No.	12		
	b) Emergency Maintained Circular shaped surface	No.	3		
	c) 8W bulkhead luminaire ,polycarbonate base, and clear diffuser and installed inside the lift shaft As Thorn EWB/ETB bulkhead. "Type G"	No.	2		
	d) Bulkhead fitting with moulded glass diffuser &	No.	14		
<b>Total Carried Forward to the Next Pg.</b>					

ITEM	DESCRIPTION	UNIT	QTY	RATE (KSH)	AMOUNT (KSH)
	<b>Total B/F from Previous Pg.</b>				
1.04	CCTV points in designated locations for surveillance, comprising of 25mm diameter HG PVC conduits complete with draw wire and the blanking plate. Allow for draw boxes where all the conduits from each security point converge.	No.	6		
1.05	300x 300x 100mm deep 16 G galvanized adaptable box.	No.	2		
	<b>LIGHTING CONTROL</b>				
1.06	Presence sensor complete with associated wiring (light and motion sensor) as Osram Duo with the following characteristics: Operation voltage 220 - 240V 50Hz, detection area-12m dia minimum, settable light value, switch-off delay (if no motion detected), installation height - 5m minimum	No.	3		
1.07	24A, 240V, 2P DB/CU mounted silent operation contactor for Switching External lights complete with all accessories and as CRABTREE CIK24 or an approved equivalent	No.	2		
1.08	Photocell control unit and wired to energize the contactors complete with a D.P override switch as THORN QPK or approved equivalent	No.	2		
1.09	Water booster power points completely wired in 5 x 6mm <sup>2</sup> single core PVC insulated copper cables drawn in 38mm diameter heavy gauge PVC conduits including all accessories ,but excluding the the 40A TPN isolator	No.	1		
1.10	40A TPN isolator as MK or approved equivalent	No.	1		
	<b>Total Carried Forward to the Next Pg.</b>				

ITEM	DESCRIPTION	UNIT	QTY	RATE (KSH)	AMOUNT (KSH)
	<b>Total B/F from Previous Pg.</b>				
1.11	Lifts isolators power points completely wired in 5 x 6mm <sup>2</sup> single core PVC insulated copper cables drawn in 32mm diameter heavy gauge PVC conduits including all accessories ,but excluding the the 63A TPN isolator	No.	2		
1.12	63A TPN isolator as MK or approved equivalent	No.	2		
1.13	8 ways 100A TPN distribution boards 'T' complete with 100A TPN integral isolator ,but excluding the MCBs ,and as Schneider Electric Acti 9 or approved equivalent.	No.	1		
1.14	4 ways 100A SPN Consumer Unit `C' complete with 100A SPN integral isolator ,but excluding the MCBs ,and as Schneider Electric Acti 9 or approved equivalent for common services.	No.	5		
1.15	<b>MCBs for item above as Schneider Electric Acti 9</b>				
	i)10 A SP MCB	No.	6		
	ii) 32 A SP MCB	No.	4		
	iii) 40 A SP MCB	No.	5		
	iv) 32 A TP MCB	No.	3		
	v) Blanking plates	No.	8		
1.16	Sub-mains circuits for DB 'T' above comprising of 4 core 25mm <sup>2</sup> PVC/SWA/PVC cable drawn in cable tray/ 50mm diameter heavy gauge conduits and running from the Lv switchboard	LM	10		
<b>Total Carried Forward to the Next Pg.</b>					

ITEM	DESCRIPTION	UNIT	QTY	RATE (KSH)	AMOUNT (KSH)
	<b>Total B/F from Previous Pg.</b>				
1.17	Sub-mains circuits for CU 'C ' above comprising of 3 x 10mm <sup>2</sup> single core PVC insulated copper cables drawn in 32mm heavy gauge conduits and running from common distribution board.	LM	30		
1.18	200mm x 50mm galvanised metallic cable tray (Telecom, DTV, Internet Cables) gauge 14 (riser duct) c/w all mounting accessories bends, rawl bolts, threaded bolts, brackets,	LM.	60		
1.19	200mm x 50mm galvanised metallic cable tray (Power Cables) gauge 14 (riser duct) c/w all mounting accessories bends, rawl bolts, threaded bolts, brackets,	LM.	40		
<b>Total Carried Forward to Ground Floor Collection Pg.</b>					



ITEM	DESCRIPTION	QTY	RATE (KSH)	AMOUNT (KSH)
<b>GROUND FLOOR SUMMARY PAGE</b>				
1	Total Amount for 2 Bedroom AHP Unit	4		
2	Total Amount for 3 Bedroom AHP Unit	1		
3	Total Amount for Studio/1 Room AHP Unit	4		
4	Total Amount for 2 Room Social Unit	2		
5	Total Amount for 3 Room Social Unit	1		
6	Total Amount for Common Area	1		
<b>Total Carried Forward to Ground Floor Collection Pg.</b>				

ITEM	DESCRIPTION	UNIT	QTY	RATE (KSH)	AMOUNT (KSH)
(ii)	<b>TYPICAL 1ST - 9TH FLOOR</b>				
A.	<b>2 BEDROOM AHP UNITS</b>				
	SUPPLY, DELIVER , INSTALL ,SET TO WORK AND COMMISSION THE FOLLOWING:-				
	<b>LIGHTING POINTS</b>				
1.01	Lighting point completely wired in 3 x 1.5mm <sup>2</sup> single core PVC insulated copper cables drawn in 20mm diameter heavy gauge PVC conduits including all accessories for one way switching, but excluding the switch and luminaire.	No.	6		
	ii) Ditto as in item No. 1.01 but for two way switching	No.	4		
1.02	10A white moulded switch plate as Crabtree, MK Logic, Clipsal E- Series or approved equivalent as follows:-				
	i) 10A one gang one way switch	No.	3		
	ii) 10A one gang two way switch	No.	5		
	iii) 10A two gang two way switch	No.	2		
1.03	<b>LIGHTING FITTINGS</b>				
	a) Ceiling rose complete with 3 core flex cable, lamp holder and 11W led lamp as crabtree or approved equivalent <b>Type 'CR'</b>	No.	6		
	b) Spherical screwneck luminaire with opal glass and 16W compact fluorescent lamp as Astra, Micromark, Thorn or approved equivalent. <b>"Type BF"</b>	No.	2		
<b>Total Carried Forward to the Next Pg.</b>					

ITEM	DESCRIPTION	UNIT	QTY	RATE (KSH)	AMOUNT (KSH)
	<b>Total B/F from Previous Pg.</b>				
	<b>POWER AND SOCKET OUTLET POINTS</b>				
1.04	13A SP socket point completely wired in 3 x 2.5mm <sup>2</sup> single core PVC insulated copper cables drawn in 25mm diameter heavy gauge PVC conduits including all accessories but excluding the 13A SP switched socket outlet.	No.	7		
1.05	Socket Outlet plates i) 13A SP twin switched socket outlet as MK 2536 or approved equivalent.	No.	7		
1.06	Instant shower water heater power points completely wired in 3 x 4mm <sup>2</sup> single core PVC insulated copper cables drawn in 25mm diameter heavy gauge PVC conduits including all accessories, but excluding the 40A DP connection unit	No.	1		
1.07	40A DP switched connection unit with neon indicator as MK or approved equivalent	No.	1		
1.08	Cooker outlet power points completely wired in 3 x 6.0mm <sup>2</sup> single core PVC insulated copper cables drawn in 32mm diameter heavy gauge PVC conduits including all accessories, but excluding the 45A Cooker connection unit	No.	1		
1.09	45A Moulded plate Cooker Control Unit complete with 13A fused Socket outlet as MK/Crabtree or approved equivalent.	No.	1		
1.10	45A moulded plate cooker connection unit as MK/Crabtree or approved equivalent:	No.	1		
	<b>Total Carried Forward to the Next Pg.</b>				

ITEM	DESCRIPTION	UNIT	QTY	RATE (KSH)	AMOUNT (KSH)
	<b>Total B/F from Previous Pg.</b>				
1.11	Domestic door bell point completely wired in 3 x 1.5mm <sup>2</sup> single core PVC insulated copper cables drawn in 20mm diameter heavy gauge PVC conduits including all accessories but excluding the bell.	No.	1		
1.12	240V/12V Ding dong domestic door bell	No.	1		
	<b>TELEPHONE, DATA AND TV POINTS POINTS</b>				
1.13	Data point comprising of draw wire in 25mm diameter Heavy Gauge PVC conduits including all accessories and blanking cover but excluding the Data socket outlet.	No.	1		
1.14	DTV Socket point comprising of draw wire in 25mm diameter Heavy Gauge PVC conduits including all accessories and blanking cover but excluding the DTV socket outlet.	No.	1		
1.15	300x 300x 100mm deep 16G galvanized adaptable box.	No.	2		
1.16	25mm diameter PVC HG conduit for ICT services and linking the Draw Boxes to the ICT ducts	LM	45		
<b>Total Carried Forward to the Next Pg.</b>					

ITEM	DESCRIPTION	UNIT	QTY	RATE (KSH)	AMOUNT (KSH)
	<b>Total B/F from Previous Pg.</b>				
	<b>POWER RETICULATION AND DISTRIBUTION BOARDS</b>				
1.17	6 ways 100A SPN Consumer Unit 'A' complete with 100A SPN integral isolator, but excluding the MCBs ,and as Schneider Electric Acti 9 or approved equivalent.	No.	1		
1.18	<b>MCBs for item above as Schneider Electric Acti 9</b>				
	i)10 A SP MCB	No.	1		
	ii)32 A SP MCB	No.	2		
	iii) 45 A SP MCB	No.	1		
	iv) Blanking plates	No.	2		
1.19	Sub-mains circuits for CU 'A ' above comprising of 3 x 10mm <sup>2</sup> single core PVC insulated copper cables drawn in 32mm heavy gauge conduits and running from the LV switchboard below the staircase.	LM	65		
<b>Total Carried Forward to Typical Floor Collection Pg.</b>					

ITEM	DESCRIPTION	UNIT	QTY	RATE (KSH)	AMOUNT (KSH)
<b>B.</b>	<b><u>3 BEDROOM AHP UNIT</u></b>				
	SUPPLY, DELIVER , INSTALL ,SET TO WORK AND COMMISSION THE FOLLOWING:-				
	<b>LIGHTING POINTS</b>				
1.01	Lighting point completely wired in 3 x 1.5mm <sup>2</sup> single core PVC insulated copper cables drawn in 20mm diameter heavy gauge PVC conduits including all accessories for one way switching, but excluding the switch and luminaire.	No.	4		
	ii) Ditto as in item No. 1.01 but for two way switching	No.	6		
1.02	10A white moulded switch plate as Crabtree, MK Logic, Clipsal E- Series or approved equivalent as follows:-				
	i) 10A one gang one way switch	No.	4		
	ii) 10A one gang two way switch	No.	8		
	iii) 10A two gang two way switch	No.	1		
1.03	<b>LIGHTING FITTINGS</b>				
	a) Ceiling rose complete with 3 core flex cable, lamp holder and 11W led lamp as crabtree or approved equivalent <b>Type 'CR'</b>	No.	7		
	b) Spherical screwneck luminaire with opal glass and 16W compact fluorescent lamp as Astra, Micromark, Thorn or approved equivalent. <b>"Type BF"</b>	No.	3		
<b>Total Carried Forward to the Next Pg.</b>					

ITEM	DESCRIPTION	UNIT	QTY	RATE (KSH)	AMOUNT (KSH)
	<b>Total B/F from Previous Pg.</b>				
	<b>POWER AND SOCKET OUTLET POINTS</b>				
1.04	13A SP socket point completely wired in 3 x 2.5mm <sup>2</sup> single core PVC insulated copper cables drawn in 25mm diameter heavy gauge PVC conduits including all accessories but excluding the 13A SP switched socket outlet.	No.	8		
1.05	Socket Outlet plates i) 13A SP twin switched socket outlet as MK 2536 or equal & approved equivalent.	No.	8		
1.06	Instant shower water heater power points completely wired in 3 x 4mm <sup>2</sup> single core PVC insulated copper cables drawn in 25mm diameter heavy gauge PVC conduits including all accessories, but excluding the 40A DP connection unit	No.	2		
1.07	40A DP switched connection unit with neon indicator as MK or approved equivalent	No.	2		
1.08	Cooker outlet power points completely wired in 3 x 6.0mm <sup>2</sup> single core PVC insulated copper cables drawn in 32mm diameter heavy gauge PVC conduits including all accessories, but excluding the 45A DP connection unit	No.	1		
1.09	45A Moulded plate Cooker Control Unit complete with 13A fused socket outlet as MK/Crabtree or approved equivalent.	No.	1		
1.10	45A Moulded plate Cooker Control Unit complete with 13A fused Socket outlet as MK/Crabtree or approved equivalent.	No.	1		
	<b>Total Carried Forward to the Next Pg.</b>				

ITEM	DESCRIPTION	UNIT	QTY	RATE (KSH)	AMOUNT (KSH)
	<b>Total B/F from Previous Pg.</b>				
1.11	Domestic door bell point completely wired in 3 x 1.5mm <sup>2</sup> single core PVC insulated copper cables drawn in 20mm diameter heavy gauge PVC conduits including all accessories but excluding the bell.	No.	1		
1.12	240V/12V Ding dong domestic door bell	No.	1		
	<b>TELEPHONE, DATA AND TV POINTS POINTS</b>				
1.13	Data point comprising of draw wire in 25mm diameter Heavy Gauge PVC conduits including all accessories and blanking cover but excluding the telephone socket outlet.	No.	1		
1.14	DTV Socket point comprising of draw wire in 25mm diameter Heavy Gauge PVC conduits including all accessories and blanking cover but excluding the DTV socket outlet.	No.	1		
1.15	300x 300x 100mm deep 16G galvanized adaptable box.	No.	2		
1.16	25 mm diameter PVC HG conduit for ICT services and linking the Draw Boxes to the ICT ducts	LM	45		
<b>Total Carried Forward to the Next Pg.</b>					



ITEM	DESCRIPTION	UNIT	QTY	RATE (KSH)	AMOUNT (KSH)
	<b>Total B/F from Previous Pg.</b>				
	<b>POWER RETICULATION AND DISTRIBUTION BOARDS</b>				
1.17	6 ways 100A SPN Consumer Unit `A' complete with 100A SPN integral isolator ,but excluding the MCBs, and as Schneider Electric Acti 9 or approved equivalent.	No.	1		
1.18	<b>MCBs for item above as Schneider Electric Acti 9</b>				
	i)10 A SP MCB	No.	1		
	ii)32 A SP MCB	No.	3		
	iii) 45 A SP MCB	No.	1		
	iv) Blanking plates	No.	1		
1.19	Sub-mains circuits for CU 'A ' above comprising of 3 x 10mm <sup>2</sup> single core PVC insulated copper cables drawn in 32mm heavy gauge conduits and running from the Lv switchboard below the staircase.	LM	65		
<b>Total Carried Forward to Typical Floor Collection Pg.</b>					

ITEM	DESCRIPTION	UNIT	QTY	RATE (KSH)	AMOUNT (KSH)
C.	<b><u>STUDIO/1 ROOM UNITS</u></b>				
	SUPPLY, DELIVER , INSTALL ,SET TO WORK AND COMMISSION THE FOLLOWING:-				
	<b>LIGHTING POINTS</b>				
1.01	Lighting point completely wired in 3 x 1.5mm <sup>2</sup> single core PVC insulated copper cables drawn in 20mm diameter heavy gauge PVC conduits including all accessories for one way switching, but excluding the switch and luminaire.	No.	1		
	ii) Ditto as in item No. 1.01 but for two way switching	No.	2		
1.02	10A white moulded switch plate as Crabtree, MK Logic, Clipsal E- Series or approved equivalent as follows:-				
	i) 10A one gang one way switch	No.	1		
	ii) 10A one gang two way switch	No.	2		
	iii) 10A two gang two way switch	No.	1		
1.03	<b>LIGHTING FITTINGS</b>				
	a) Ceiling rose complete with 3 core flex cable, lamp holder and 11W led lamp as crabtree or approved equivalent <b>Type 'CR'</b>	No.	2		
	b) Spherical screwneck luminaire with opal glass and 16W compact fluorescent lamp as Astra, Micromark, Thorn or approved equivalent. <b>"Type BF"</b>	No.	1		
<b>Total Carried Forward to the Next Pg.</b>					

ITEM	DESCRIPTION	UNIT	QTY	RATE (KSH)	AMOUNT (KSH)
	<b>Total B/F from Previous Pg.</b>				
	<b>POWER AND SOCKET OUTLET POINTS</b>				
1.04	13A SP socket point completely wired in 3 x 2.5mm <sup>2</sup> single core PVC insulated copper cables drawn in 25mm diameter heavy gauge PVC conduits including all accessories but excluding the 13A SP switched socket outlet.	No.	4		
1.05	Socket Outlet plates i) 13A SP twin switched socket outlet as MK 2536 or equal & approved equivalent.	No.	4		
1.06	Instant shower water heater power points completely wired in 3 x 4mm <sup>2</sup> single core PVC insulated copper cables drawn in 25mm diameter heavy gauge PVC conduits including all accessories ,but excluding the 40A DP connection unit	No.	1		
1.07	40A DP switched connection unit with neon indicator as MK or approved equivalent	No.	1		
1.08	Cooker outlet power points completely wired in 3 x 6.0mm <sup>2</sup> single core PVC insulated copper cables drawn in 32mm diameter heavy gauge PVC conduits including all accessories ,but excluding the 45A DP connection unit	No.	1		
1.09	45A Moulded plate Cooker Control Unit complete with 13A fused Socket outlet as MK/Crabtree or approved equivalent.	No.	1		
1.10	45A moulded plate cooker connection unit as MK/Crabtree or approved equivalent:	No.	1		
	<b>Total Carried Forward to the Next Pg.</b>				

ITEM	DESCRIPTION	UNIT	QTY	RATE (KSH)	AMOUNT (KSH)
	<b>Total B/F from Previous Pg.</b>				
1.11	Domestic door bell point completely wired in 3 x 1.5mm <sup>2</sup> single core PVC insulated copper cables drawn in 20mm diameter heavy gauge PVC conduits including all accessories but excluding the bell.	No.	1		
1.12	240V/12V Ding dong domestic door bell	No.	1		
	<b>TELEPHONE, DATA AND TV POINTS POINTS</b>				
1.13	Data point comprising of draw wire in 25mm diameter Heavy Gauge PVC conduits including all accessories and blanking plate but excluding the telephone socket outlet.	No.	1		
1.14	DTV Socket point comprising of draw wire in 25mm diameter Heavy Gauge PVC conduits including all accessories but excluding the DTV socket outlet.	No.	1		
1.15	300x 300x 100mm deep 16G galvanized adaptable box.	No.	2		
1.16	25mm diameter PVC HG conduit for ICT services and linking the Draw Boxes to the ICT ducts	LM	30		
	<b>Total Carried Forward to the Next Pg.</b>				

ITEM	DESCRIPTION	UNIT	QTY	RATE (KSH)	AMOUNT (KSH)
	<b>Total B/F from Previous Pg.</b>				
	<b>POWER RETICULATION AND DISTRIBUTION BOARDS</b>				
1.17	6 ways 100A SPN Consumer Unit 'A' complete with 100A SPN integral isolator ,but excluding the MCBs ,and as Schneider Electric Acti 9 or approved equivalent.	No.	1		
1.18	<b>MCBs for item above as Schneider Electric Acti 9</b>				
	i)10 A SP MCB	No.	1		
	ii)32 A SP MCB	No.	3		
	iii) 45 A SP MCB	No.	1		
	iv) Blanking plates	No.	1		
1.19	Sub-mains circuits for CU 'A ' above comprising of 3 x 10mm <sup>2</sup> single core PVC insulated copper cables drawn in 32mm heavy gauge conduits and running from the LV switchboard below the staircase.	LM	50		
<b>Total Carried Forward to Typical Floor Collection Pg.</b>					

ITEM	DESCRIPTION	UNIT	QTY	RATE (KSH)	AMOUNT (KSH)
<b>D.</b>	<b><u>2 ROOM SOCIAL UNITS</u></b>				
	SUPPLY, DELIVER , INSTALL ,SET TO WORK AND COMMISSION THE FOLLOWING:-				
	<b>LIGHTING POINTS</b>				
1.01	Lighting point completely wired in 3 x 1.5mm <sup>2</sup> single core PVC insulated copper cables drawn in 20mm diameter heavy gauge PVC conduits including all accessories for one way switching, but excluding the switch and luminaire.	No.	2		
	ii) Ditto as in item No. 1.01 but for two way switching	No.	3		
1.02	10A white moulded switch plate as Crabtree, MK Logic, Clipsal E- Series or approved equivalent as follows:-				
	i) 10A two gang one way switch	No.	1		
	ii) 10A one gang two way switch	No.	3		
	iii) 10A two gang two way switch	No.	1		
1.03	<b>LIGHTING FITTINGS</b>				
	a) Ceiling rose complete with 3 core flex cable, lamp holder and 11W led lamp as crabtree or approved equivalent <b>Type 'CR'</b>	No.	4		
	b) Spherical screwneck luminaire with opal glass and 16W compact fluorescent lamp as Astra, Micromark, Thorn or approved equivalent. <b>"Type BF"</b>	No.	1		
<b>Total Carried Forward to the Next Pg.</b>					

ITEM	DESCRIPTION	UNIT	QTY	RATE (KSH)	AMOUNT (KSH)
	<b>Total B/F from Previous Pg.</b>				
	<b>POWER AND SOCKET OUTLET POINTS</b>				
1.04	13A SP socket point completely wired in 3 x 2.5mm <sup>2</sup> single core PVC insulated copper cables drawn in 25mm diameter heavy gauge PVC conduits including all accessories but excluding the 13A SP switched socket outlet.	No.	6		
1.05	Socket Outlet plates i) 13A SP twin switched socket outlet as MK 2536 or equal & approved equivalent.	No.	6		
1.06	Instant shower water heater power points completely wired in 3 x 4mm <sup>2</sup> single core PVC insulated copper cables drawn in 25mm diameter heavy gauge PVC conduits including all accessories, but excluding the 40A DP connection unit	No.	1		
1.07	40A DP switched connection unit with neon indicator as MK or approved equivalent	No.	1		
1.08	Cooker outlet power points completely wired in 3 x 6.0mm <sup>2</sup> single core PVC insulated copper cables drawn in 32mm diameter heavy gauge PVC conduits including all accessories ,but excluding the 45A DP connection unit	No.	1		
1.09	45A Moulded plate Cooker Control Unit complete with 13A fused socket outlet as MK/Crabtree or approved equivalent.	No.	1		
1.10	45A moulded plate cooker connection unit as MK/Crabtree or approved equivalent:	No.	1		
	<b>Total Carried Forward to the Next Pg.</b>				

ITEM	DESCRIPTION	UNIT	QTY	RATE (KSH)	AMOUNT (KSH)
	<b>Total B/F from Previous Pg.</b>				
1.11	Domestic door bell point completely wired in 3 x 1.5mm <sup>2</sup> single core PVC insulated copper cables drawn in 20mm diameter heavy gauge PVC conduits including all accessories but excluding the bell.	No.	1		
1.12	240V/12V Ding dong domestic door bell	No.	1		
	<b>TELEPHONE, DATA AND TV POINTS POINTS</b>				
1.13	Data point comprising of draw wire in 25mm diameter Heavy Gauge PVC conduits including all accessories and blanking plate but excluding the data socket outlet.	No.	1		
1.14	DTV Socket point comprising of draw wire in 25mm diameter Heavy Gauge PVC conduits including all accessories but excluding the DTV socket outlet.	No.	1		
1.15	300x 300x 100mm deep 16G galvanized adaptable box.	No.	2		
1.16	25mm diameter PVC HG conduit for ICT services and linking the Draw Boxes to the ICT ducts	LM	20		
	<b>Total Carried Forward to the Next Pg.</b>				



ITEM	DESCRIPTION	UNIT	QTY	RATE (KSH)	AMOUNT (KSH)
	<b>Total B/F from Previous Pg.</b>				
	<b>POWER RETICULATION AND DISTRIBUTION BOARDS</b>				
1.17	6 ways 100A SPN Consumer Unit 'A' complete with 100A SPN integral isolator, but excluding the MCBs ,and as Schneider Electric Acti 9 or approved equivalent.	No.	1		
1.18	<b>MCBs for item above as Schneider Electric Acti 9</b>				
	i)10 A SP MCB	No.	1		
	ii)32 A SP MCB	No.	3		
	iii) 45 A SP MCB	No.	1		
	iv) Blanking plates	No.	1		
1.19	Sub-mains circuits for CU 'A ' above comprising of 3 x 10mm <sup>2</sup> single core PVC insulated copper cables drawn in 32mm heavy gauge conduits and running from the LVswitchboard below the staircase.	LM	30		
<b>Total Carried Forward to Typical Floor Collection Pg.</b>					

ITEM	DESCRIPTION	UNIT	QTY	RATE (KSH)	AMOUNT (KSH)
E.	<b><u>3 ROOM SOCIAL UNIT</u></b>				
	SUPPLY, DELIVER , INSTALL ,SET TO WORK AND COMMISSION THE FOLLOWING:-				
	<b>LIGHTING POINTS</b>				
1.01	Lighting point completely wired in 3 x 1.5mm <sup>2</sup> single core PVC insulated copper cables drawn in 20mm diameter heavy gauge PVC conduits including all accessories for one way switching, but excluding the switch and luminaire.	No.	2		
	ii) Ditto as in item No. 1.01 but for two way switching	No.	5		
1.02	10A white moulded switch plate as Crabtree, MK Logic, Clipsal E- Series or approved equivalent as follows:-				
	i) 10A one gang one way switch	No.	1		
	ii) 10A one gang two way switch	No.	4		
	iii) 10A two gang two way switch	No.	3		
1.03	<b>LIGHTING FITTINGS</b>				
	a) Ceiling rose complete with 3 core flex cable, lamp holder and 11W led lamp as crabtree or approved equivalent <b>Type 'CR'</b>	No.	6		
	b) Spherical screwneck luminaire with opal glass and 16W compact fluorescent lamp as Astra, Micromark, Thorn or approved equivalent. <b>"Type BF"</b>	No.	1		
<b>Total Carried Forward to the Next Pg.</b>					

ITEM	DESCRIPTION	UNIT	QTY	RATE (KSH)	AMOUNT (KSH)
	<b>Total B/F from Previous Pg.</b>				
	<b>POWER AND SOCKET OUTLET POINTS</b>				
1.04	13A SP socket point completely wired in 3 x 2.5mm <sup>2</sup> single core PVC insulated copper cables drawn in 25mm diameter heavy gauge PVC conduits including all accessories but excluding the 13A SP switched socket outlet.	No.	7		
1.05	Socket Outlet plates i) 13A SP twin switched socket outlet as MK 2536 or equal & approved equivalent.	No.	7		
1.06	Instant shower water heater power points completely wired in 3 x 4mm <sup>2</sup> single core PVC insulated copper cables drawn in 25mm diameter heavy gauge PVC conduits including all accessories, but excluding the 40A DP connection unit	No.	1		
1.07	40A DP switched connection unit with neon indicator as MK or approved equivalent	No.	1		
1.08	Cooker outlet power points completely wired in 3 x 6.0mm <sup>2</sup> single core PVC insulated copper cables drawn in 32mm diameter heavy gauge PVC conduits including all accessories, but excluding the 45A DP connection unit	No.	1		
1.09	45A Moulded plate Cooker Control Unit complete with 13A fused socket outlet as MK/Crabtree or approved equivalent.	No.	1		
1.10	45A Moulded plate Cooker Control Unit complete with 13A fused Socket outlet as MK/Crabtree or approved equivalent.	No.	1		
	<b>Total Carried Forward to the Next Pg.</b>				

ITEM	DESCRIPTION	UNIT	QTY	RATE (KSH)	AMOUNT (KSH)
	<b>Total B/F from Previous Pg.</b>				
1.11	Domestic door bell point completely wired in 3 x 1.5mm <sup>2</sup> single core PVC insulated copper cables drawn in 20mm diameter heavy gauge PVC conduits including all accessories but excluding the bell.	No.	1		
1.12	240V/12V Ding dong domestic door bell	No.	1		
	<b>TELEPHONE, DATA AND TV POINTS POINTS</b>				
1.13	Data point comprising of draw wire in 25mm diameter Heavy Gauge PVC conduits including all accessories and blanking cover but excluding the telephone socket outlet.	No.	1		
1.14	DTV Socket point comprising of draw wire in 25mm diameter Heavy Gauge PVC conduits including all accessories and blanking cover but excluding the DTV socket outlet.	No.	1		
1.15	300x 300x 100mm deep 16G galvanized adaptable box.	No.	2		
1.16	25mm diameter PVC HG conduit for ICT services and linking the Draw Boxes to the ICT ducts	Lm.	20		
	<b>Total Carried Forward to the Next Pg.</b>				

ITEM	DESCRIPTION	UNIT	QTY	RATE (KSH)	AMOUNT (KSH)
	<b>Total B/F from Previous Pg.</b>				
	<b>POWER RETICULATION AND DISTRIBUTION BOARDS</b>				
1.17	6 ways 100A SPN Consumer Unit `A' complete with 100A SPN integral isolator ,but excluding the MCBs, and as Schneider Electric Acti 9 or approved equivalent.	No.	1		
1.18	<b>MCBs for item above as Schneider Electric Acti 9</b>				
	i)10 A SP MCB	No.	1		
	ii)32 A SP MCB	No.	3		
	iii) 45 A SP MCB	No.	1		
	iv) Blanking plates	No.	1		
1.19	Sub-mains circuits for CU 'A ' above comprising of 3 x 10mm <sup>2</sup> single core PVC insulated copper cables drawn in 32mm heavy gauge conduits and running from the Lv switchboard below the staircase.	LM	45		
<b>Total Carried Forward to Typical Floor Collection Pg.</b>					

ITEM	DESCRIPTION	UNIT	QTY	RATE (KSH)	AMOUNT (KSH)
F.	<b><u>CORRIDOR/LIFTS LOBBY AREA</u></b>				
	SUPPLY, DELIVER , INSTALL ,SET TO WORK AND COMMISSION THE FOLLOWING:-				
	<b>LIGHTING POINTS</b>				
1.01	Lighting point completely wired in 3 x 1.5mm <sup>2</sup> single core PVC insulated copper cables drawn in 20mm diameter heavy gauge PVC conduits including all accessories for two way switching, but excluding the switch and luminaire.	No.	20		
1.02	10A white moulded switch plate as Crabtree, MK Logic, Clipsal E- Series or approved equivalent as follows:-				
	i) 10A one gang two way switch	No.	5		
	ii) 10A two gang two way switch	No.	5		
1.03	<b>LIGHTING FITTINGS</b>				
	a) Circular shaped surface mounted led luminaire	No.	12		
	b) Emergency Maintained Circular shaped surface	No.	3		
	c) 8W bulkhead luminaire ,polycarbonate base, and clear diffuser and installed inside the lift shaft As Thorn EWB/ETB bulkhead. "Type G"	No.	2		
<b>Total Carried Forward to Next Pg.</b>					

ITEM	DESCRIPTION	UNIT	QTY	RATE (KSH)	AMOUNT (KSH)
	<b>Total B/F from Previous Pg.</b>				
1.04	CCTV points in designated locations for surveillance, comprising of 25mm diameter HG PVC conduits complete with draw wire and the blanking plate. Allow for draw boxes where all the conduits from each security point converge.	No.	6		
1.05	300x 300x 100mm deep 16G galvanized adaptable box.	No.	2		
	<b>LIGHTING CONTROL</b>				
1.06	Presence sensor complete with associated wiring (light and motion sensor) as Osram Duo with the following characteristics:  Operation voltage 220 - 240V 50Hz, detection area-12m dia minimum, settable light value, switch-off delay (if no motion detected), installation height - 5m minimum	No.	3		
<b>Total Carried Forward to Next Pg.</b>					

ITEM	DESCRIPTION	QTY	RATE (KSH)	AMOUNT (KSH)
	<b>TYPICAL FLOOR SUMMARY</b>			
1	Total Amount for 2 Bedroom AHP Unit	36		
2	Total Amount for 3 Bedroom AHP Unit	9		
3	Total Amount for Studio AHP Unit	18		
4	Total Amount for 1 Room Social Unit	9		
5	Total Amount for 2 Room Social Unit	18		
6	Total Amount for 3 Room Social Unit	9		
7	Total Amount for Common Area	9		
<b>Total for 9No. Typical Floor Carried Forward to Main Summary Page</b>				



ITEM	DESCRIPTION	UNIT	QTY	RATE (KSH)	AMOUNT (KSH)
(iii)	<b><u>EARTHING AND LIGHTNING PROTECTION</u></b>				
	SUPPLY, DELIVER , INSTALL ,SET TO WORK AND COMMISSION THE FOLLOWING:-				
	<b>Air Termination</b>				
1.01	2000mm x15mmØ multiple point pure copper AirRods/ Termination with spikes as Furse Part No. RA240 or approved equivalent	No.	3		
1.02	Copper Air Rod Base as Furse Part No. SD105-H or approved equivalent	No.	3		
1.03	Copper Junction Clamps for copper tape as Furse Part No. CN105-H or approved equivalent	No.	3		
1.04	25mm x 3mm Tinned Copper Tape as Furse TC230 or approved equivalent	Lm.	150		
	<b>Down Conductor</b>				
1.05	25mm x 3mm Tinned Copper Tape as Furse TC230 or approved equivalent	Lm.	250		
1.06	Screwdown copper test clamp as Furse CT305 or approved equivalent	No.	3		
1.07	38mm Ø HG PVC conduits for drawing the down conductor above.	Lm.	10		
<b>Total Carried Forward to Next Pg.</b>					

ITEM	DESCRIPTION	UNIT	QTY	RATE (KSH)	AMOUNT (KSH)
	<b>Total B/F from Previous Pg.</b>				
	<b>Earth Termination</b>				
1.08	15mm Ø, 1500mm long solid copper earth rod c/w driving stud, coupling, and spike as Furse RC011 or approved equivalent	No	3		
1.09	Earth rod to tape clamp type A as Furse CR108 or approved equivalent	No.	3		
1.10	Concrete inspection earth pit Cat. No. PT 005 with 5 hole earth bar as Furse Cat. No. PT 006.	No.	2		
1.11	600mm x 600mm copper earth mat made from 25mm x 3mm copper tape at 300mm spacing, buried to permanent moisture level and complete with all clamps and 6m long 25mm x 3mm copper tape clamped to the down conductor, soil conditioning agents (marconite or bentonite) as necessary to achieve earthing resistance value below 10-Ohms	Lot	1		
1.12	Allow for earthing tests for the above and submission of the report to the engineer to BS7671 & BS62305 standards	No.	1		
1.13	<b>Bonding</b> Bonding and clamping to all metal work including water pipes, gas pipes, hand-rails, smatv system, window frames, cladding, metal roof etc. and the main earth for the building.	Item	1		
<b>Total Carried Forward to Main Summary Pg.</b>					

ITEM	DESCRIPTION	UNIT	QTY	RATE (KSH)	AMOUNT (KSH)
(iv)	<b><u>SMATV SYSTEM</u></b>				
	SUPPLY, DELIVER , INSTALL ,SET TO WORK AND COMMISSION THE FOLLOWING:-				
1.01	KU Band Satellite Receiver Dish	No.	1		
1.02	UHF Terrestrial antenna capable of receiving all local channels	No.	1		
1.03	Distribution amplifiers 30 dB gain, indoor distribution amplifier c/w 240 volts DC 9 watts Amps power supply, make: ALCAD or equal and approved.	No.	2		
1.04	16 output shielded splitter 2DB loss ALCAD or equal and approved.	No	6		
1.05	75-Ohm RG6 TV signal Coaxial cable complete with connectors interconnecting the satellite dish, aerial, amplifiers and splitters.	Lm.	1500		
1.06	DTV outlet plates as MK or Approved equivalent	No.	131		
1.07	9U Cabinet to house equipments, such as amplifiers, splitters etc	No.	1		
<b>Total Carried Forward to Main Summary Pg.</b>					

ITEM	DESCRIPTION	UNIT	QTY	RATE (KSH)	AMOUNT (KSH)
(V)	<b><u>LV SWITCHBOARD INSTALLATION &amp; EARTHING</u></b>				
	TAKE DELIVERY, STORE, INSTALL AND COMMISSION THE FOLLOWING:-				
1.01	Install purpose made Free-standing, fully wired front access metal clad main switchboard cubicle suitable for floor / wall mounting and manufactured in 14SWG galvanised mild steel sheet, to be finished in cream (or appropriate colour) powder coating. Wiring as shown on the schematic (the other details as per Particular Specification), complete with the following:-	Item	1		
(i)	400Amps TP/N copper busbars - KPLC supply (Sealable)				
(ii)	400Amps MCCB as mains incomer adjustable				
(iii)	Space for 1No. 3-phase KPLC Common Services meter (kW, kWh, kVA, V, I etc), 63A TP MCB				
(iv)	120No. 63A DP MCBs for the sub-main cables				
(v)	1No. 100A DP MCBs for the sub-main cables				
(vi)	Space for KPLC cut-outs including studs for mounting KPLC seals				
(vii)	Sealable studs for all cover plate screws and all necessary accessories				
(viii)	6mm perspex viewing window for each section				
(ix)	Heavy duty rubber lining for all the perspex viewing windows				
(x)	4 No. Spare ways				
<b>Total Carried Forward to Next Page</b>					

ITEM	DESCRIPTION	UNIT	QTY	RATE (KSH)	AMOUNT (KSH)
1.02	<p><b>Total B/F from Previous Pg.</b></p> <p>Earthing for the switch-board under this section comprising 25x3mm copper tape lead, 1800mm long x 15mm diameter copper earth electrode as Furse or approved equivalent complete with driving stud and tape to rod clamp, 300mm x 300mm x 300mm deep concrete inspection earth pit with removable waterproof cover, 600mm x 600mm copper earth mat, soil conditioning agents (marconite and bentonite etc) necessary to achieve earthing value below 5-Ohms and all other necessary accessories</p>	No.	1		
<b>Total Carried Forward to Main Summary Pg.</b>					

ITEM	DESCRIPTION	AMOUNT (KSH)
<b>BLOCK TYPE A SUMMARY PAGE</b>		
1	Total Amount for Ground Floor B/F Page 25	
2	Total Amount for Typical 1st - 4th Floor B/F Page 48	
3	Total Amount for Lightning Protection B/F Page 50	
4	Total Amount for SMATV B/F Page 51	
5	Total Amount for LV Switchboard Installation and Earthing B/F Page 53	
<b>TOTAL AMOUNT FOR BILL No. 1: TYPICAL 1NO. BLOCK TYPE A CARRIED FORWARD TO PRICE COLLECTION PAGE</b>		

ITEM	DESCRIPTION	UNIT	QTY	RATE (KSH)	AMOUNT (KSH)
	<b><u>BILL NO. 3</u></b>				
	<b><u>PROPOSED TYPICAL AFFORDABLE &amp; MARKET UNITS BLOCK TYPE B</u></b>				
	<b>(i) <u>GROUND FLOOR</u></b>				
	<b>A. <u>2 BEDROOM AHP UNITS</u></b>				
	SUPPLY, DELIVER , INSTALL ,SET TO WORK AND COMMISSION THE FOLLOWING:-				
	<b>LIGHTING POINTS</b>				
2.01	i) Lighting point completely wired in 3 x 1.5mm <sup>2</sup> single core PVC insulated copper cables drawn in 20mm diameter heavy gauge PVC conduits including all accessories for one way switching, but excluding the switch and luminaire.	No.	3		
	ii) Ditto as in item No. 2.01 but for two way switching	No.	6		
2.02	10A white moulded switch plate as Crabtree, MK Logic, Clipsal E- Series or approved equivalent as follows:-				
	i) 10A one gang one way switch	No.	3		
	ii) 10A one gang two way switch	No.	6		
	iii) 10A two gang two way switch	No.	2		
2.03	<b>LIGHTING FITTINGS</b>				
	a) Ceiling rose complete with 3 core flex cable, lamp holder and 11W led lamp as crabtree or approved equivalent <b>Type 'CR'</b>	No.	6		
	b) Spherical screwneck luminaire with opal glass and 16W compact lamp as Astra, Micromark, Thorn or approved equivalent. <b>"Type BF"</b>	No.	2		
<b>Total Carried Forward to the Next Pg.</b>					

ITEM	DESCRIPTION	UNIT	QTY	RATE (KSH)	AMOUNT (KSH)
	<b>Total B/F from Previous Pg.</b>				
	<b>POWER AND SOCKET OUTLET POINTS</b>				
2.04	13A SP socket point completely wired in 3 x 2.5mm <sup>2</sup> single core PVC insulated copper cables drawn in 25mm diameter heavy gauge PVC conduits including all accessories but excluding the 13A SP switched socket outlet.	No.	8		
2.05	Socket Outlet plates i) 13A SP twin switched socket outlet as MK 2536 or approved equivalent.	No.	8		
2.06	Instant shower water heater power points completely wired in 3 x 4mm <sup>2</sup> single core PVC insulated copper cables drawn in 25mm diameter heavy gauge PVC conduits including all accessories, but excluding the 40A DP connection unit	No.	1		
2.07	40A DP switched connection unit with neon indicator as MK or approved equivalent	No.	1		
2.08	Cooker outlet power points completely wired in 3 x 6.0mm <sup>2</sup> single core PVC insulated copper cables drawn in 32mm diameter heavy gauge PVC conduits including all accessories, but excluding the 45A Cooker connection unit	No.	1		
2.09	45A Moulded plate Cooker Control Unit complete with 13A fused Socket outlet as MK/Crabtree or approved equivalent.	No.	1		
2.10	45A moulded plate cooker connection unit as MK/Crabtree or approved equivalent:	No.	1		
	<b>Total Carried Forward to the Next Pg.</b>				



ITEM	DESCRIPTION	UNIT	QTY	RATE (KSH)	AMOUNT (KSH)
	<b>Total B/F from Previous Pg.</b>				
2.11	Domestic door bell point completely wired in 3 x 1.5mm <sup>2</sup> single core PVC insulated copper cables drawn in 20mm diameter heavy gauge PVC conduits including all accessories but excluding the bell.	No.	1		
2.12	240V/12V Ding dong domestic door bell as Oxford or approved equivalent	No.	1		
	<b>TELEPHONE, DATA AND TV POINTS POINTS</b>				
2.13	Data point comprising of draw wire in 25mm diameter Heavy Gauge PVC conduits including all accessories and blanking cover but excluding the Data socket outlet.	No.	1		
2.14	DTV Socket point comprising of draw wire in 25mm diameter Heavy Gauge PVC conduits including all accessories and blanking cover but excluding the DTV socket outlet.	No.	1		
2.15	300x 300x 100mm deep 16G galvanized adaptable box.	No.	2		
2.16	25mm diameter PVC HG conduit for ICT services and linking the Draw Boxes to the ICT ducts	Lm.	20		
	<b>Total Carried Forward to Next Pg.</b>				

ITEM	DESCRIPTION	UNIT	QTY	RATE (KSH)	AMOUNT (KSH)
	<b>Total B/F from Previous Pg.</b>				
	<b>POWER RETICULATION AND DISTRIBUTION BOARDS</b>				
2.17	6 ways 100A SPN Consumer Unit `A' complete with 100A SPN integral isolator, but excluding the MCBs ,and as Schneider Electric Acti 9 or approved equivalent.	No.	1		
2.18	<b>MCBs for item above as Schneider Electric Acti 9</b>				
	i)10 A SP MCB	No.	1		
	ii)32 A SP MCB	No.	2		
	iii) 45 A SP MCB	No.	1		
	iv) Blanking plates	No.	2		
2.19	Sub-mains circuits for CU 'A ' above comprising of 3 x 10mm <sup>2</sup> single core PVC insulated copper cables drawn in 32mm heavy gauge conduits and running from the LV switchboard below the staircase.	LM	20		
<b>Total Carried Forward to Ground Floor Collection Page</b>					

ITEM	DESCRIPTION	UNIT	QTY	RATE (KSH)	AMOUNT (KSH)
<b>B.</b>	<b><u>3 BEDROOM AHP UNITS</u></b>				
	SUPPLY, DELIVER, INSTALL, SET TO WORK AND COMMISSION THE FOLLOWING:-				
	<b>LIGHTING POINTS</b>				
2.01	i) Lighting point completely wired in 3 x 1.5mm <sup>2</sup> single core PVC insulated copper cables drawn in 20mm diameter heavy gauge PVC conduits including all accessories for one way switching, but excluding the switch and luminaire.	No.	4		
	ii) Ditto as in item No. 2.01 but for two way switching	No.	8		
2.02	10A white moulded switch plate as Crabtree, MK Logic, Clipsal E- Series or approved equivalent as follows:-				
	i) 10A one gang one way switch	No.	5		
	ii) 10A one gang two way switch	No.	8		
	iii) 10A two gang two way switch	No.	2		
2.03	<b>LIGHTING FITTINGS</b>				
	a) Ceiling rose complete with 3 core flex cable, lamp holder and 11W led lamp as crabtree or approved equivalent <b>Type 'CR'</b>	No.	9		
	b) Spherical screwneck luminaire with opal glass and 16W compact lamp as Astra, Micromark, Thorn or approved equivalent. <b>"Type BF"</b>	No.	2		
<b>Total Carried Forward to the Next Pg.</b>					

ITEM	DESCRIPTION	UNIT	QTY	RATE (KSH)	AMOUNT (KSH)
	<b>Total B/F from Previous Pg.</b>				
	<b>POWER AND SOCKET OUTLET POINTS</b>				
2.04	13A SP socket point completely wired in 3 x 2.5mm <sup>2</sup> single core PVC insulated copper cables drawn in 25mm diameter heavy gauge PVC conduits including all accessories but excluding the 13A SP switched socket outlet.	No.	11		
2.05	Socket Outlet plates i) 13A SP twin switched socket outlet as MK 2536 or equal & approved equivalent.	No.	11		
2.06	Instant shower water heater power points completely wired in 3 x 4mm <sup>2</sup> single core PVC insulated copper cables drawn in 25mm diameter heavy gauge PVC conduits including all accessories, but excluding the 40A DP connection unit	No.	2		
2.07	40A DP switched connection unit with neon indicator as MK or approved equivalent	No.	2		
2.08	Cooker outlet power points completely wired in 3 x 6.0mm <sup>2</sup> single core PVC insulated copper cables drawn in 32mm diameter heavy gauge PVC conduits including all accessories, but excluding the 45A DP connection unit	No.	1		
2.09	45A Moulded plate Cooker Control Unit complete with 13A fused socket outlet as MK/Crabtree or approved equivalent.	No.	1		
2.10	45A Moulded plate Cooker Control Unit complete with 13A fused Socket outlet as MK/Crabtree or approved equivalent.	No.	1		
	<b>Total Carried Forward to the Next Pg.</b>				

ITEM	DESCRIPTION	UNIT	QTY	RATE (KSH)	AMOUNT (KSH)
	<b>Total B/F from Previous Pg.</b>				
2.11	Domestic door bell point completely wired in 3 x 1.5mm <sup>2</sup> single core PVC insulated copper cables drawn in 20mm diameter heavy gauge PVC conduits including all accessories but excluding the bell.	No.	1		
2.12	240V/12V Ding dong domestic door bell as Oxfrud or approved equivalent	No.	1		
	<b>TELEPHONE, DATA AND TV POINTS POINTS</b>				
3.13	Data point comprising of draw wire in 25mm diameter Heavy Gauge PVC conduits including all accessories and blanking cover but excluding the telephone socket outlet.	No.	1		
2.14	DTV Socket point comprising of draw wire in 25mm diameter Heavy Gauge PVC conduits including all accessories and blanking cover but excluding the DTV socket outlet.	No.	1		
2.15	300x 300x 100mm deep 16G galvanized adaptable box.	No.	2		
2.16	25mm diameter PVC HG conduit for ICT services and linking the Draw Boxes to the ICT ducts	Lm.	20		
<b>Total Carried Forward to the Next Pg.</b>					

ITEM	DESCRIPTION	UNIT	QTY	RATE (KSH)	AMOUNT (KSH)
	<b>Total B/F from Previous Pg.</b>				
	<b>POWER RETICULATION AND DISTRIBUTION BOARDS</b>				
2.17	6 ways 100A SPN Consumer Unit `A' complete with 100A SPN integral isolator ,but excluding the MCBs, and as Schneider Electric Acti 9 or approved equivalent.	No.	1		
2.18	<b>MCBs for item above as Schneider Electric Acti 9</b>				
	i)10 A SP MCB	No.	1		
	ii)32 A SP MCB	No.	3		
	iii) 45 A SP MCB	No.	1		
	iv) Blanking plates	No.	1		
2.19	Sub-mains circuits for CU 'A ' above comprising of 3 x 10mm <sup>2</sup> single core PVC insulated copper cables drawn in 32mm heavy gauge conduits and running from the Lv switchboard below the staircase.	LM	45		
<b>Total Carried Forward to Ground Floor Collection Page</b>					

ITEM	DESCRIPTION	UNIT	QTY	RATE (KSH)	AMOUNT (KSH)
C.	<b><u>2 BEDROOM MARKET UNITS</u></b>				
	SUPPLY, DELIVER, INSTALL, SET TO WORK AND COMMISSION THE FOLLOWING:-				
	<b>LIGHTING POINTS</b>				
2.01	i) Lighting point completely wired in 3 x 1.5mm <sup>2</sup> single core PVC insulated copper cables drawn in 20mm diameter heavy gauge PVC conduits including all accessories for one way switching, but excluding the switch and luminaire.	No.	5		
	ii) Ditto as in item No. 2.01 but for two way switching	No.	5		
2.02	10A white moulded switch plate as Crabtree, MK Logic, Clipsal E- Series or approved equivalent as follows:-				
	i) 10A one gang one way switch	No.	4		
	ii) 10A two gang one way switch	No.	1		
	iii) 10A one gang two way switch	No.	6		
	iv) 10A two gang two way switch	No.	2		
2.03	<b>LIGHTING FITTINGS</b>				
	a) Ceiling rose complete with 3 core flex cable, lamp holder and 11W led lamp as crabtree or approved equivalent <b>Type 'CR'</b>	No.	7		
	b) Spherical screwneck luminaire with opal glass and 16W compact lamp as Astra, Micromark, Thorn or approved equivalent. <b>"Type BF"</b>	No.	2		
<b>Total Carried Forward to the Next Pg.</b>					

ITEM	DESCRIPTION	UNIT	QTY	RATE (KSH)	AMOUNT (KSH)
	<b>Total B/F from Previous Pg.</b>				
	<b>POWER AND SOCKET OUTLET POINTS</b>				
2.04	13A SP socket point completely wired in 3 x 2.5mm <sup>2</sup> single core PVC insulated copper cables drawn in 25mm diameter heavy gauge PVC conduits including all accessories but excluding the 13A SP switched socket outlet.	No.	9		
2.05	Socket Outlet plates i) 13A SP twin switched socket outlet as MK 2536 or equal & approved equivalent.	No.	9		
2.06	Instant shower water heater power points completely wired in 3 x 4mm <sup>2</sup> single core PVC insulated copper cables drawn in 25mm diameter heavy gauge PVC conduits including all accessories ,but excluding the 40A DP connection unit	No.	2		
2.07	40A DP switched connection unit with neon indicator as MK or approved equivalent	No.	2		
2.08	Cooker outlet power points completely wired in 3 x 6.0mm <sup>2</sup> single core PVC insulated copper cables drawn in 32mm diameter heavy gauge PVC conduits including all accessories ,but excluding the 45A DP connection unit	No.	1		
2.09	45A Moulded plate Cooker Control Unit complete with 13A fused Socket outlet as MK/Crabtree or approved equivalent.	No.	1		
2.10	45A moulded plate cooker connection unit as MK/Crabtree or approved equivalent:	No.	1		
	<b>Total Carried Forward to the Next Pg.</b>				



ITEM	DESCRIPTION	UNIT	QTY	RATE (KSH)	AMOUNT (KSH)
	<b>Total B/F from Previous Pg.</b>				
2.11	Domestic door bell point completely wired in 3 x 1.5mm <sup>2</sup> single core PVC insulated copper cables drawn in 20mm diameter heavy gauge PVC conduits including all accessories but excluding the bell.	No.	1		
2.12	240V/12V Ding dong domestic door bell	No.	1		
	<b>TELEPHONE, DATA AND TV POINTS POINTS</b>				
2.13	Data point comprising of draw wire in 25mm diameter Heavy Gauge PVC conduits including all accessories and blanking plate but excluding the telephone socket outlet.	No.	1		
2.14	DTV Socket point comprising of draw wire in 25mm diameter Heavy Gauge PVC conduits including all accessories but excluding the DTV socket outlet.	No.	1		
2.15	300x 300x 100mm deep 16G galvanized adaptable box.	No.	2		
2.16	25mm diameter PVC HG conduit for ICT services and linking the Draw Boxes to the ICT ducts	Lm.	40		
<b>Total Carried Forward to the Next Pg.</b>					

ITEM	DESCRIPTION	UNIT	QTY	RATE (KSH)	AMOUNT (KSH)
	<b>Total B/F from Previous Pg.</b>				
	<b>POWER RETICULATION AND DISTRIBUTION BOARDS</b>				
2.17	6 ways 100A SPN Consumer Unit `A' complete with 100A SPN integral isolator ,but excluding the MCBs ,and as Schneider Electric Acti 9 or approved equivalent.	No.	1		
2.18	<b>MCBs for item above as Schneider Electric Acti 9</b>				
	i)10 A SP MCB	No.	1		
	ii)32 A SP MCB	No.	3		
	iii) 45 A SP MCB	No.	1		
	iv) Blanking plates	No.	1		
2.19	Sub-mains circuits for CU 'A ' above comprising of 3 x 10mm <sup>2</sup> single core PVC insulated copper cables drawn in 32mm heavy gauge conduits and running from the LV switchboard below the staircase.	LM	40		
<b>Total Carried Forward to Ground Floor Collection Page</b>					

ITEM	DESCRIPTION	UNIT	QTY	RATE (KSH)	AMOUNT (KSH)
<b>D.</b>	<b><u>3 BEDROOM MARKET UNITS</u></b>				
	SUPPLY, DELIVER, INSTALL, SET TO WORK AND COMMISSION THE FOLLOWING:-				
	<b>LIGHTING POINTS</b>				
2.01	Lighting point completely wired in 3 x 1.5mm <sup>2</sup> single core PVC insulated copper cables drawn in 20mm diameter heavy gauge PVC conduits including all accessories for one way switching, but excluding the switch and luminaire.	No.	5		
	ii) Ditto as in item No. 2.01 but for two way switching	No.	7		
2.02	10A white moulded switch plate as Crabtree, MK Logic, Clipsal E- Series or approved equivalent as follows:-				
	i) 10A one gang one way switch	No.	5		
	ii) 10A one gang two way switch	No.	6		
	iii) 10A two gang two way switch	No.	4		
2.03	<b>LIGHTING FITTINGS</b>				
	a) Ceiling rose complete with 3 core flex cable, lamp holder and 11W led lamp as crabtree or approved equivalent <b>Type 'CR'</b>	No.	8		
	b) Spherical screwneck luminaire with opal glass and 16W compact fluorescent lamp as Astra, Micromark, Thorn or approved equivalent. <b>"Type BF"</b>	No.	3		
<b>Total Carried Forward to the Next Pg.</b>					

ITEM	DESCRIPTION	UNIT	QTY	RATE (KSH)	AMOUNT (KSH)
	<b>Total B/F from Previous Pg.</b>				
	<b>POWER AND SOCKET OUTLET POINTS</b>				
2.04	13A SP socket point completely wired in 3 x 2.5mm <sup>2</sup> single core PVC insulated copper cables drawn in 25mm diameter heavy gauge PVC conduits including all accessories but excluding the 13A SP switched socket outlet.	No.	12		
2.05	Socket Outlet plates i) 13A SP twin switched socket outlet as MK 2536 or equal & approved equivalent.	No.	12		
2.06	Instant shower water heater power points completely wired in 3 x 4mm <sup>2</sup> single core PVC insulated copper cables drawn in 25mm diameter heavy gauge PVC conduits including all accessories, but excluding the 40A DP connection unit	No.	2		
2.07	40A DP switched connection unit with neon indicator as MK or approved equivalent	No.	2		
2.08	Cooker outlet power points completely wired in 3 x 6.0mm <sup>2</sup> single core PVC insulated copper cables drawn in 32mm diameter heavy gauge PVC conduits including all accessories ,but excluding the 45A DP connection unit	No.	1		
2.09	45A Moulded plate Cooker Control Unit complete with 13A fused socket outlet as MK/Crabtree or approved equivalent.	No.	1		
2.10	45A moulded plate cooker connection unit as MK/Crabtree or approved equivalent:	No.	1		
	<b>Total Carried Forward to the Next Pg.</b>				

ITEM	DESCRIPTION	UNIT	QTY	RATE (KSH)	AMOUNT (KSH)
	<b>Total B/F from Previous Pg.</b>				
2.11	Domestic door bell point completely wired in 3 x 1.5mm <sup>2</sup> single core PVC insulated copper cables drawn in 20mm diameter heavy gauge PVC conduits including all accessories but excluding the bell.	No.	1		
2.12	240V/12V Ding dong domestic door bell as Oxford or approved equivalent	No.	1		
	<b>TELEPHONE, DATA AND TV POINTS POINTS</b>				
2.13	Data point comprising of draw wire in 25mm diameter Heavy Gauge PVC conduits including all accessories and blanking plate but excluding the data socket outlet.	No.	1		
2.14	DTV Socket point comprising of draw wire in 25mm diameter Heavy Gauge PVC conduits including all accessories but excluding the DTV socket outlet.	No.	1		
2.15	300x 300x 100mm deep 16G galvanized adaptable box.	No.	2		
2.16	32mm diameter PVC HG conduit for ICT services and linking the Draw Boxes to the ICT ducts	Lm.	40		
<b>Total Carried Forward to the Next Pg.</b>					

ITEM	DESCRIPTION	UNIT	QTY	RATE (KSH)	AMOUNT (KSH)
	<b>Total B/F from Previous Pg.</b>				
	<b>POWER RETICULATION AND DISTRIBUTION BOARDS</b>				
2.17	6 ways 100A SPN Consumer Unit 'A' complete with 100A SPN integral isolator, but excluding the MCBs ,and as Schneider Electric Acti 9 or approved equivalent.	No.	1		
2.18	<b>MCBs for item above as Schneider Electric Acti 9</b>				
	i)10 A SP MCB	No.	1		
	ii)32 A SP MCB	No.	3		
	iii) 45 A SP MCB	No.	1		
	iv) Blanking plates	No.	1		
2.19	Sub-mains circuits for CU 'A ' above comprising of 3 x 10mm <sup>2</sup> single core PVC insulated copper cables drawn in 32mm heavy gauge conduits and running from the LVswitchboard below the staircase.	LM	40		
<b>Total Carried Forward to Ground Floor Collection Page</b>					

ITEM	DESCRIPTION	UNIT	QTY	RATE (KSH)	AMOUNT (KSH)
E.	<b><u>CORRIDOR/ LIFTS LOBBY AREA</u></b>				
	SUPPLY, DELIVER , INSTALL ,SET TO WORK AND COMMISSION THE FOLLOWING:-				
	<b>LIGHTING POINTS</b>				
2.01	Lighting point completely wired in 3 x 1.5mm <sup>2</sup> single core PVC insulated copper cables drawn in 20mm diameter heavy gauge PVC conduits including all accessories for two way switching, but excluding the switch and luminaire.	No.	32		
2.02	10A white moulded switch plate as Crabtree, MK Logic, Clipsal E- Series or approved equivalent as follows:-				
	i) 10A one gang two way switch	No.	4		
	ii) 10A two gang two way switch	No.	4		
2.03	<b>LIGHTING FITTINGS</b>				
	a) Circular shaped surface mounted led luminaire as Phillips Coreline Cat No. WL131V LED12S/840 PSED EL3 WH "Type N"	No.	15		
	b) Emergency Maintained Circular shaped surface mounted led luminaire as Phillips Coreline Cat No. WL131V LED12S/840 PSED EL3 WH "Type Ne"	No.	3		
	c) 8W bulkhead luminaire ,polycarbonate base, and clear diffuser and installed inside the lift shaft As Thorn EWB/ETB bulkhead. "Type G"	No.	2		
	d) Bulkhead fitting with moulded glass diffuser & Die Cast Aluminium base c/w 16W PL Lamp as Massive Sunderland Cat. No. 71410/01/31 for security lights. "Type B"	No.	14		
<b>Total Carried Forward to Next Pg.</b>					

ITEM	DESCRIPTION	UNIT	QTY	RATE (KSH)	AMOUNT (KSH)
	<b>Total B/F from Previous Pg.</b>				
2.04	CCTV points in designaed locations for survailance, comprising of 25mm diameter HG PVC conduits complete with draw wire and the blanking plate. Allow for draw boxes where all the conduits from each security point converge.	No.	6		
2.05	300x 300x 100mm deep 16 G galvanized adaptable box.	No.	2		
	<b>LIGHTING CONTROL</b>				
2.06	Presence sensor complete with assocaited wiring (light and motion sensor) as Osram Duo with the following characteristics:  Operation voltage 220 - 240V 50Hz, detection area-12m dia minimum, settable light value, switch-off delay (if no motion detected), installation height - 5m minimum	No.	3		
2.07	24A, 240V, 2P DB/CU mounted silent operation contactor for Switching External lights complete with all accessories and as CRABTREE CIK24 or an approved equivalent	No.	2		
2.08	Photocell control unit and wired to energize the contactors complete with a D.P override switch as THORN QPK or approved equivalent	No.	2		
3.09	Water booster power points completely wired in 5 x 6mm <sup>2</sup> single core PVC insulated copper cables drawn in 38mm diameter heavy gauge PVC conduits including all accessories ,but excluding the the 40A TPN isolator	No.	1		
	<b>Total Carried Forward to Next Pg.</b>				



ITEM	DESCRIPTION	UNIT	QTY	RATE (KSH)	AMOUNT (KSH)
	<b>Total B/F from Previous Pg.</b>				
2.10	40A TPN isolator as MK or approved equivalent	No.	1		
2.11	Lifts isolators power points completely wired in 5 x 6mm <sup>2</sup> single core PVC insulated copper cables drawn in 32mm diameter heavy gauge PVC conduits including all accessories ,but excluding the the 63A TPN isolator	No.	2		
2.12	63A TPN isolator as MK or approved equivalent	No.	2		
2.13	8 ways 100A TPN distribution boards 'T' complete with 100A TPN integral isolator ,but excluding the MCBs ,and as Schneider Electric Acti 9 or approved equivalent.	No.	1		
2.14	4 ways 100A SPN Consumer Unit `C' complete with 100A SPN integral isolator ,but excluding the MCBs ,and as Schneider Electric Acti 9 or approved equivalent for common services.	No.	5		
2.15	<b>MCBs for item above as Schneider Electric Acti 9</b>				
	i)10 A SP MCB	No.	6		
	ii) 32 A SP MCB	No.	4		
	iii) 40 A SP MCB	No.	5		
	iv) 32 A TP MCB	No.	3		
	v) Blanking plates	No.	8		
2.16	Sub-mains circuits for DB 'T' above comprising of 4 core 25mm <sup>2</sup> PVC/SWA/PVC cable drawn in cable tray/ 50mm diameter heavy gauge conduits and running from the Lv switchboard	LM	30		
	<b>Total Carried Forward to Next Pg.</b>				

ITEM	DESCRIPTION	UNIT	QTY	RATE (KSH)	AMOUNT (KSH)
	<b>Total B/F from Previous Pg.</b>				
2.17	Sub-mains circuits for CU 'C ' above comprising of 3 x 10mm <sup>2</sup> single core PVC insulated copper cables drawn in 32mm heavy gauge conduits and running from common distribution board.	LM	60		
2.18	200mm x 50mm galvanised metallic cable tray (Telecom, DTV, Internet Cables) gauge 14 (riser duct) c/w all mounting accessories bends, rawl bolts, threaded bolts, brackets,	LM.	40		
2.19	300mm x 50mm galvanised metallic cable tray (Power Cables) gauge 14 (riser duct) c/w all mounting accessories bends, rawl bolts, threaded bolts, brackets,	LM.	40		
<b>Total Carried Forward to Ground Floor Collection Page</b>					

ITEM	DESCRIPTION	QTY	RATE (KSH)	AMOUNT (KSH)
<b>GROUND FLOOR SUMMARY</b>				
1	Total Amount for 2 Bedroom AHP Unit	1		
2	Total Amount for 3 Bedroom AHP Unit	1		
3	Total Amount for 2 Bedroom Market Unit	3		
4	Total Amount for 3 Bedroom Market Unit	3		
5	Total Amount for Ground Floor Lobby	1		
<b>Total Carried Forwad to Main Summary Page</b>				

ITEM NO.	DESCRIPTION	UNIT	QTY	RATE KShs	AMOUNT KShs
	<b><u>BILL NO. 2</u></b>				
(ii)	<b><u>TYPICAL 1ST - 9TH FLOOR</u></b>				
A.	<b><u>2 BEDROOM AHP UNITS</u></b>				
	SUPPLY, DELIVER , INSTALL ,SET TO WORK AND COMMISSION THE FOLLOWING:-				
	<b>LIGHTING POINTS</b>				
2.01	i) Lighting point completely wired in 3 x 1.5mm <sup>2</sup> single core PVC insulated copper cables drawn in 20mm diameter heavy gauge PVC conduits including all accessories for one way switching, but excluding the switch and luminaire.	No.			
	ii) Ditto as in item No. 2.01 but for two way switching	No.			
2.02	10A white moulded switch plate as Crabtree, MK Logic, Clipsal E- Series or approved equivalent as follows:-				
	i) 10A one gang one way switch	No.			
	ii) 10A one gang two way switch	No.			
	iii) 10A two gang two way switch	No.			
2.03	<b>LIGHTING FITTINGS</b>				
	a) Ceiling rose complete with 3 core flex cable, lamp holder and 11W led lamp as crabtree or approved equivalent <b>Type 'CR'</b>	No.			
	b) Spherical screwneck luminaire with opal glass and 16W compact lamp as Astra, Micromark, Thornor equal & approved equivalent. "Type BF"	No.			
<b>Total Carried Forward to Next Pg.</b>					

ITEM	DESCRIPTION	UNIT	QTY	RATE (KSH)	AMOUNT (KSH)
	<b>Total B/F from Previous Pg.</b>				
	<b>POWER AND SOCKET OUTLET POINTS</b>				
2.04	13A SP socket point completely wired in 3 x 2.5mm <sup>2</sup> single core PVC insulated copper cables drawn in 25mm diameter heavy gauge PVC conduits including all accessories but excluding the 13A SP switched socket outlet.	No.	8		
2.05	Socket Outlet plates i) 13A SP twin switched socket outlet as MK 2536 or equal & approved equivalent.	No.	8		
2.06	Instant shower water heater power points completely wired in 3 x 4mm <sup>2</sup> single core PVC insulated copper cables drawn in 25mm diameter heavy gauge PVC conduits including all accessories ,but excluding the 40A DP connection unit	No.	1		
2.07	40A DP switched connection unit with neon indicator as MK or approved equivalent	No.	1		
2.08	Cooker outlet power points completely wired in 3 x 6.0mm <sup>2</sup> single core PVC insulated copper cables drawn in 32mm diameter heavy gauge PVC conduits including all accessories ,but excluding the 45A DP connection unit	No.	1		
2.09	45A Moulded plate Cooker Control Unit complete with 13A fused socket outlet as MK/Crabtree or approved equivalent.	No.	1		
2.10	45A moulded plate cooker connection unit as MK/Crabtree or approved equivalent:	No.	1		
	<b>Total Carried Forward to Next Pg.</b>				

ITEM	DESCRIPTION	UNIT	QTY	RATE (KSH)	AMOUNT (KSH)
	<b>Total B/F from Previous Pg.</b>				
2.11	Domestic door bell point completely wired in 3 x 1.5mm <sup>2</sup> single core PVC insulated copper cables drawn in 20mm diameter heavy gauge PVC conduits including all accessories but excluding the bell.	No.	1		
2.12	240V/12V Ding dong domestic door bell	No.	1		
	<b>TELEPHONE, DATA AND TV POINTS POINTS</b>				
2.13	Data point comprising of draw wire in 25mm diameter Heavy Gauge PVC conduits including all accessories and blanking plate but excluding the data socket outlet.	No.	1		
2.14	DTV Socket point comprising of draw wire in 25mm diameter Heavy Gauge PVC conduits including all accessories but excluding the DTV socket outlet.	No.	1		
2.15	300x 300x 100mm deep 16G galvanized adaptable box.	No.	2		
2.16	25mm diameter PVC HG conduit for ICT services and linking the Draw Boxes to the ICT ducts	Lm.	20		
<b>Total Carried Forward to Next Pg.</b>					

ITEM	DESCRIPTION	UNIT	QTY	RATE (KSH)	AMOUNT (KSH)
	<b>Total B/F from Previous Pg.</b>				
	<b>POWER RETICULATION AND DISTRIBUTION BOARDS</b>				
2.17	6 ways 100A SPN Consumer Unit `A' complete with 100A SPN integral isolator ,but excluding the MCBs ,and as Schneider Electric Acti 9 or approved equivalent.	No.	1		
2.18	<b>MCBs for item above as Schneider Electric Acti 9</b>				
	i)10 A SP MCB	No.	1		
	ii)32 A SP MCB	No.	2		
	iii) 45 A SP MCB	No.	1		
	iv) Blanking plates	No.	2		
2.19	Sub-mains circuits for CU 'A ' above comprising of 3 x 10mm <sup>2</sup> single core PVC insulated copper cables drawn in 32mm heavy gauge conduits and running from the Lv switchboard below the staircase.	LM	40		
<b>Total Carried Forward to First Floor Collection Page</b>					

ITEM	DESCRIPTION	UNIT	QTY	RATE (KSH)	AMOUNT (KSH)
<b>B.</b>	<b><u>3 BEDROOM AHP UNITS</u></b>				
	SUPPLY, DELIVER, INSTALL, SET TO WORK AND COMMISSION THE FOLLOWING:-				
	<b>LIGHTING POINTS</b>				
2.01	Lighting point completely wired in 3 x 1.5mm <sup>2</sup> single core PVC insulated copper cables drawn in 20mm diameter heavy gauge PVC conduits including all accessories for one way switching, but excluding the switch and luminaire.	No.	4		
	ii) Ditto as in item No. 2.01 but for two way switching	No.	8		
2.02	10A white moulded switch plate as Crabtree, MK Logic, Clipsal E- Series or approved equivalent as follows:-				
	i) 10A one gang one way switch	No.	5		
	ii) 10A one gang two way switch	No.	8		
	iii) 10A two gang two way switch	No.	2		
2.03	<b>LIGHTING FITTINGS</b>				
	a) Ceiling rose complete with 3 core flex cable, lamp holder and 11W led lamp as crabtree or approved equivalent <b>Type 'CR'</b>	No.	9		
	b) Spherical screwneck luminaire with opal glass and 16W compact fluorescent lamp as Astra, Micromark, Thornor equal & approved equivalent. "Type BF"	No.	2		
<b>Total Carried Forward to Next Pg.</b>					



ITEM	DESCRIPTION	UNIT	QTY	RATE (KSH)	AMOUNT (KSH)
	<b>Total B/F from Previous Pg.</b>				
	<b>POWER AND SOCKET OUTLET POINTS</b>				
2.04	13A SP socket point completely wired in 3 x 2.5mm <sup>2</sup> single core PVC insulated copper cables drawn in 25mm diameter heavy gauge PVC conduits including all accessories but excluding the 13A SP switched socket outlet.	No.	11		
2.05	Socket Outlet plates i) 13A SP twin switched socket outlet as MK 2536 or equal & approved equivalent.	No.	11		
2.06	Instant shower water heater power points completely wired in 3 x 4mm <sup>2</sup> single core PVC insulated copper cables drawn in 25mm diameter heavy gauge PVC conduits including all accessories ,but excluding the 40A DP connection unit	No.	2		
2.07	40A DP switched connection unit with neon indicator as MK or approved equivalent	No.	2		
2.08	Cooker outlet power points completely wired in 3 x 6.0mm <sup>2</sup> single core PVC insulated copper cables drawn in 32mm diameter heavy gauge PVC conduits including all accessories ,but excluding the 45A DP connection unit	No.	1		
2.09	45A Moulded plate Cooker Control Unit complete with 13A fused socket outlet as MK/Crabtree or approved equivalent.	No.	1		
2.10	45A moulded plate cooker connection unit as MK/Crabtree or approved equivalent:	No.	1		
<b>Total Carried Forward to Next Pg.</b>					

ITEM	DESCRIPTION	UNIT	QTY	RATE (KSH)	AMOUNT (KSH)
	<b>Total B/F from Previous Pg.</b>				
3.11	Domestic door bell point completely wired in 3 x 1.5mm <sup>2</sup> single core PVC insulated copper cables drawn in 20mm diameter heavy gauge PVC conduits including all accessories but excluding the bell.	No.	1		
3.12	240V/12V Ding dong domestic door bell as Oxford or approved equivalent	No.	1		
	<b>TELEPHONE, DATA AND TV POINTS POINTS</b>				
2.13	Data point comprising of draw wire in 25mm diameter Heavy Gauge PVC conduits including all accessories and blanking plate but excluding the data socket outlet.	No.	1		
2.14	DTV Socket point comprising of draw wire in 25mm diameter Heavy Gauge PVC conduits including all accessories but excluding the DTV socket outlet.	No.	1		
2.15	300x 300x 100mm deep 16G galvanized adaptable box.	No.	2		
2.16	25mm diameter PVC HG conduit for ICT services and linking the Draw Boxes to the ICT ducts	Lm.	20		
	<b>Total Carried Forward to Next Pg.</b>				

ITEM	DESCRIPTION	UNIT	QTY	RATE (KSH)	AMOUNT (KSH)
	<b>Total B/F from Previous Pg.</b>				
	<b>POWER RETICULATION AND DISTRIBUTION BOARDS</b>				
2.17	6 ways 100A SPN Consumer Unit `A' complete with 100A SPN integral isolator ,but excluding the MCBs ,and as Schneider Electric Acti 9 or approved equivalent.	No.	1		
2.18	<b>MCBs for item above as Schneider Electric Acti 9</b>				
	i)10 A SP MCB	No.	1		
	ii)32 A SP MCB	No.	3		
	iii) 45 A SP MCB	No.	1		
	iv) Blanking plates	No.	1		
2.19	Sub-mains circuits for CU 'A ' above comprising of 3 x 10mm <sup>2</sup> single core PVC insulated copper cables drawn in 32mm heavy gauge conduits and running from the Lv switchboard below the staircase.	LM	65		
<b>Total Carried Forward to First Floor Collection Page</b>					

ITEM	DESCRIPTION	UNIT	QTY	RATE (KSH)	AMOUNT (KSH)
C.	<b><u>2 BEDROOM MARKET UNITS</u></b>				
	SUPPLY, DELIVER, INSTALL, SET TO WORK AND COMMISSION THE FOLLOWING:-				
	<b>LIGHTING POINTS</b>				
2.01	Lighting point completely wired in 3 x 1.5mm <sup>2</sup> single core PVC insulated copper cables drawn in 20mm diameter heavy gauge PVC conduits including all accessories for one way switching, but excluding the switch and luminaire.	No.	5		
	ii) Ditto as in item No. 2.01 but for two way switching	No.	5		
2.02	10A white moulded switch plate as Crabtree, MK Logic, Clipsal E- Series or approved equivalent as follows:-				
	i) 10A one gang one way switch	No.	4		
	ii) 10A two gang one way switch	No.	1		
	iii) 10A one gang two way switch	No.	6		
	iv) 10A two gang two way switch	No.	2		
2.03	<b>LIGHTING FITTINGS</b>				
	a) Ceiling rose complete with 3 core flex cable, lamp holder and 11W led lamp as crabtree or approved equivalent <b>Type 'CR'</b>	No.	7		
	b) Spherical screwneck luminaire with opal glass and 16W compact lamp as Astra, Micromark, Thornor equal & approved equivalent. "Type BF"	No.	2		
<b>Total Carried Forward to Next Page</b>					

ITEM	DESCRIPTION	UNIT	QTY	RATE (KSH)	AMOUNT (KSH)
	<b>Total B/F from Previous Pg.</b>				
	<b>POWER AND SOCKET OUTLET POINTS</b>				
2.04	13A SP socket point completely wired in 3 x 2.5mm <sup>2</sup> single core PVC insulated copper cables drawn in 25mm diameter heavy gauge PVC conduits including all accessories but excluding the 13A SP switched socket outlet.	No.	9		
2.05	Socket Outlet plates i) 13A SP twin switched socket outlet as MK 2536 or equal & approved equivalent.	No.	9		
2.06	Instant shower water heater power points completely wired in 3 x 4mm <sup>2</sup> single core PVC insulated copper cables drawn in 25mm diameter heavy gauge PVC conduits including all accessories ,but excluding the 40A DP connection unit	No.	2		
2.07	40A DP switched connection unit with neon indicator as MK or approved equivalent	No.	2		
2.08	Cooker outlet power points completely wired in 3 x 6.0mm <sup>2</sup> single core PVC insulated copper cables drawn in 32mm diameter heavy gauge PVC conduits including all accessories ,but excluding the 45A DP connection unit	No.	1		
2.09	45A Moulded plate Cooker Control Unit complete with 13A fused socket outlet as MK/Crabtree or approved equivalent.	No.	1		
2.10	45A moulded plate cooker connection unit as MK/Crabtree or approved equivalent:	No.	1		
	<b>Total Carried Forward to Next Page</b>				

ITEM	DESCRIPTION	UNIT	QTY	RATE (KSH)	AMOUNT (KSH)
	<b>Total B/F from Previous Pg.</b>				
2.11	Domestic door bell point completely wired in 3 x 1.5mm <sup>2</sup> single core PVC insulated copper cables drawn in 20mm diameter heavy gauge PVC conduits including all accessories but excluding the bell.	No.	1		
2.12	240V/12V Ding dong domestic door bell as Oxford or approved equivalent	No.	1		
	<b>TELEPHONE, DATA AND TV POINTS POINTS</b>				
2.13	Data point comprising of draw wire in 25mm diameter Heavy Gauge PVC conduits including all accessories and blanking plate but excluding the data socket outlet.	No.	1		
2.14	DTV Socket point comprising of draw wire in 25mm diameter Heavy Gauge PVC conduits including all accessories but excluding the DTV socket outlet.	No.	1		
2.15	300x 300x 100mm deep 16G galvanized adaptable box.	No.	2		
2.16	25mm diameter PVC HG conduit for ICT services and linking the Draw Boxes to the ICT ducts	Lm.	40		
<b>Total Carried Forward to Next Page</b>					

ITEM	DESCRIPTION	UNIT	QTY	RATE (KSH)	AMOUNT (KSH)
	<b>Total B/F from Previous Pg.</b>				
	<b>POWER RETICULATION AND DISTRIBUTION BOARDS</b>				
2.17	6 ways 100A SPN Consumer Unit `A' complete with 100A SPN integral isolator ,but excluding the MCBs ,and as Schneider Electric Acti 9 or approved equivalent.	No.	1		
2.18	<b>MCBs for item above as Schneider Electric Acti 9 or approved equivalent</b>				
	i)10 A SP MCB	No.	1		
	ii)32 A SP MCB	No.	3		
	iii) 45 A SP MCB	No.	1		
	iv) Blanking plates	No.	1		
2.19	Sub-mains circuits for CU 'A ' above comprising of 3 x 10mm <sup>2</sup> single core PVC insulated copper cables drawn in 32mm heavy gauge conduits and running from the Lv switchboard below the staircase.	LM	60		
<b>Total Carried Forward to First Floor Collection Page</b>					

ITEM	DESCRIPTION	UNIT	QTY	RATE (KSH)	AMOUNT (KSH)
<b>D.</b>	<b><u>3 BEDROOM MARKET UNITS</u></b>				
	SUPPLY, DELIVER, INSTALL, SET TO WORK AND COMMISSION THE FOLLOWING:-				
	<b>LIGHTING POINTS</b>				
2.01	Lighting point completely wired in 3 x 1.5mm <sup>2</sup> single core PVC insulated copper cables drawn in 20mm diameter heavy gauge PVC conduits including all accessories for one way switching, but excluding the switch and luminaire.	No.	5		
	ii) Ditto as in item No. 2.01 but for two way switching	No.	7		
2.02	10A white moulded switch plate as Crabtree, MK Logic, Clipsal E- Series or approved equivalent as follows:-				
	i) 10A one gang one way switch	No.	5		
	ii) 10A one gang two way switch	No.	6		
	iii) 10A two gang two way switch	No.	4		
2.03	<b>LIGHTING FITTINGS</b>				
	a) Ceiling rose complete with 3 core flex cable, lamp holder and 11W led lamp as crabtree or approved equivalent <b>Type 'CR'</b>	No.	8		
	b) Spherical screwneck luminaire with opal glass and 16W compact fluorescent lamp as Astra, Micromark, Thornor equal & approved equivalent. "Type BF"	No.	3		
<b>Total Carried Forward to Next Page</b>					



ITEM	DESCRIPTION	UNIT	QTY	RATE (KSH)	AMOUNT (KSH)
	<b>Total B/F from Previous Pg.</b>				
	<b>POWER AND SOCKET OUTLET POINTS</b>				
2.04	13A SP socket point completely wired in 3 x 2.5mm <sup>2</sup> single core PVC insulated copper cables drawn in 25mm diameter heavy gauge PVC conduits including all accessories but excluding the 13A SP switched socket outlet.	No.	12		
2.05	Socket Outlet plates i) 13A SP twin switched socket outlet as MK 2536 or equal & approved equivalent.	No.	12		
2.06	Instant shower water heater power points completely wired in 3 x 4mm <sup>2</sup> single core PVC insulated copper cables drawn in 25mm diameter heavy gauge PVC conduits including all accessories ,but excluding the 40A DP connection unit	No.	2		
3.07	40A DP switched connection unit with neon indicator as MK or approved equivalent	No.	2		
2.08	Cooker outlet power points completely wired in 3 x 6.0mm <sup>2</sup> single core PVC insulated copper cables drawn in 32mm diameter heavy gauge PVC conduits including all accessories ,but excluding the 45A DP connection unit	No.	1		
2.09	45A Moulded plate Cooker Control Unit complete with 13A fused socket outlet as MK/Crabtree or approved equivalent.	No.	1		
2.10	45A moulded plate cooker connection unit as MK/Crabtree or approved equivalent:	No.	1		
<b>Total Carried Forward to Next Page</b>					

ITEM	DESCRIPTION	UNIT	QTY	RATE (KSH)	AMOUNT (KSH)
	<b>Total B/F from Previous Pg.</b>				
2.11	Domestic door bell point completely wired in 3 x 1.5mm <sup>2</sup> single core PVC insulated copper cables drawn in 20mm diameter heavy gauge PVC conduits including all accessories but excluding the bell.	No.	1		
2.12	240V/12V Ding dong domestic door bell as Oxford or approved equivalent	No.	1		
	<b>TELEPHONE, DATA AND TV POINTS POINTS</b>				
2.13	Data point comprising of draw wire in 25mm diameter Heavy Gauge PVC conduits including all accessories and blanking plate but excluding the data socket outlet.	No.	1		
2.14	DTV Socket point comprising of draw wire in 25mm diameter Heavy Gauge PVC conduits including all accessories but excluding the DTV socket outlet.	No.	1		
2.15	300x 300x 100mm deep 16G galvanized adaptable box.	No.	2		
2.16	25mm diameter PVC HG conduit for ICT services and linking the Draw Boxes to the ICT ducts	Lm.	40		
<b>Total Carried Forward to Next Page</b>					

ITEM	DESCRIPTION	UNIT	QTY	RATE (KSH)	AMOUNT (KSH)
	<b>Total B/F from Previous Pg.</b>				
	<b>POWER RETICULATION AND DISTRIBUTION BOARDS</b>				
2.17	6 ways 100A SPN Consumer Unit `A' complete with 100A SPN integral isolator ,but excluding the MCBs ,and as Schneider Electric Acti 9 or approved equivalent.	No.	1		
2.18	<b>MCBs for item above as Schneider Electric Acti 9 or approved equivalent</b>				
	i)10 A SP MCB	No.	1		
	ii)32 A SP MCB	No.	3		
	iii) 45 A SP MCB	No.	1		
	iv) Blanking plates	No.	1		
2.19	Sub-mains circuits for CU 'A ' above comprising of 3 x 10mm <sup>2</sup> single core PVC insulated copper cables drawn in 32mm heavy gauge conduits and running from the Lv switchboard below the staircase.	LM	60		
<b>Total Carried Forward to Typical Floor Collection Page</b>					

ITEM	DESCRIPTION	UNIT	QTY	RATE (KSH)	AMOUNT (KSH)
E.	<b><u>CORRIDOR/ LIFTS LOBBY AREA</u></b>				
	SUPPLY, DELIVER , INSTALL ,SET TO WORK AND COMMISSION THE FOLLOWING:-				
	<b>LIGHTING POINTS</b>				
2.01	Lighting point completely wired in 3 x 1.5mm <sup>2</sup> single core PVC insulated copper cables drawn in 20mm diameter heavy gauge PVC conduits including all accessories for two way switching, but excluding the switch and luminaire.	No.	20		
2.02	10A white moulded switch plate as Crabtree, MK Logic, Clipsal E- Series or approved equivalent as follows:-				
	i) 10A one gang two way switch	No.	5		
	ii) 10A two gang two way switch	No.	5		
2.03	<b>LIGHTING FITTINGS</b>				
	a) Circular shaped surface mounted led luminaire as Phillips Coreline Cat No. WL131V LED12S/840 PSED EL3 WH " <b>Type N</b> "	No.	18		
	b) Emergency Maintained Circular shaped surface mounted led luminaire as Phillips Coreline Cat No. WL131V LED12S/840 PSED EL3 WH " <b>Type Ne</b> "	No.	3		
<b>Total Carried Forward to Next Page</b>					

ITEM	DESCRIPTION	UNIT	QTY	RATE (KSH)	AMOUNT (KSH)
	<b>Total B/F from Previous Pg.</b>				
2.04	CCTV points in designaed locations for survailance, comprising of 25mm diameter HG PVC conduits complete with draw wire and the blanking plate. Allow for draw boxes where all the conduits from each security point converge.	No.	6		
2.05	300x 300x 100mm deep 16G galvanized adaptable box.	No.	2		
	<b>LIGHTING CONTROL</b>				
2.06	<p>Presence sensor complete with assocaited wiring (light and motion sensor) as Osram Duo with the following characteristics:</p> <p>Operation voltage 220 - 240V 50Hz, detection area-12m dia minimum, settable light value, switch-off delay (if no motion detected), installation height - 5m minimum</p>	No.	3		
<b>Total Carried Forward to Typical Floor Collection Page</b>					

ITEM	DESCRIPTION	QTY	RATE (KSH)	AMOUNT (KSH)
<b>TYPICAL FLOOR SUMMARY</b>				
1	Total Amount for 2 Bedroom AHP Unit	9		
2	Total Amount for 3 Bedroom AHP Unit	9		
3	Total Amount for 2 Bedroom Market Unit	27		
4	Total Amount for 3 Bedroom Market Unit	27		
5	Total Amount for Lift Lobby Summary	9		
<b>Total for 9 No. Typical Floors Carried Forward to Main Summary Page</b>				

ITEM	DESCRIPTION	UNIT	QTY	RATE (KSH)	AMOUNT (KSH)
(iii)	<b><u>EARTHING AND LIGHTNING PROTECTION</u></b>				
	SUPPLY, DELIVER, INSTALL, SET TO WORK AND COMMISSION THE FOLLOWING:-				
	<b>Air Termination</b>				
2.01	2000mm x15mmØ multiple point pure copper AirRods/ Termination with spikes as Furse Part No. RA240 or approved equivalent	No.	3		
2.02	Copper Air Rod Base as Furse Part No. SD105-H or approved equivalent	No.	3		
2.03	Copper Junction Clamps for copper tape as Furse Part No. CN105-H or approved equivalent	No.	3		
2.04	25mm x 3mm Tinned Copper Tape as Furse TC230 or approved equivalent	Lm.	150		
	<b>Down Conductor</b>				
2.05	25mm x 3mm Tinned Copper Tape as Furse TC230 or approved equivalent	Lm.	250		
2.06	Screwdown copper test clamp as Furse CT305 or approved equivalent	No.	3		
2.07	38mm Ø HG PVC conduits for drawing the down conductor above.	Lm.	10		
<b>Total Carried Forward to Next Page</b>					

ITEM	DESCRIPTION	UNIT	QTY	RATE (KSH)	AMOUNT (KSH)
	<b>Total B/F from Previous Pg.</b>				
	<b>Earth Termination</b>				
2.08	15mm Ø, 1500mm long solid copper earth rod c/w driving stud, coupling, and spike as Furse RC011 or approved equivalent	No	3		
2.09	Earth rod to tape clamp type A as Furse CR108 or approved equivalent	No.	3		
2.10	Concrete inspection earth pit Cat. No. PT 005 with 5 hole earth bar as Furse Cat. No. PT 006.	No.	2		
2.11	600mm x 600mm copper earth mat made from 25mm x 3mm copper tape at 300mm spacing, buried to permanent moisture level and complete with all clamps and 6m long 25mm x 3mm copper tape clamped to the down conductor, soil conditioning agents (marconite or bentonite) as necessary to achieve earthing resistance value below 10-Ohms	Lot	1		
2.12	Allow for earthing tests for the above and submission of the report to the engineer to BS7671 & BS62305 standards	No.	1		
2.13	<b>Bonding</b> Bonding and clamping to all metal work including water pipes, gas pipes, hand-rails, smatv system, window frames, cladding, metal roof etc. and the main earth for the building.	Item	1		
<b>Total Carried Forward to Main Summary Page</b>					



ITEM	DESCRIPTION	UNIT	QTY	RATE (KSH)	AMOUNT (KSH)
(iv)	<b><u>SMATV SYSTEM</u></b>				
	SUPPLY, DELIVER , INSTALL ,SET TO WORK AND COMMISSION THE FOLLOWING:-				
2.01	KU Band Satellite Receiver Dish	No.	1		
2.02	UHF Terrestrial antenna capable of receiving all local channels	No.	1		
2.03	Distribution amplifiers 30 dB gain, indoor distribution amplifier c/w 240 volts DC 9 watts Amps power supply, make: ALCAD or equal and approved.	No.	2		
2.04	16 output shielded splitter 2DB loss ALCAD or equal and approved.	No	6		
2.05	75-Ohm RG6 TV signal Coaxial cable complete with connectors interconnecting the satellite dish, aerial, amplifiers and splitters.	Lm.	1500		
2.06	DTV outlet plates as MK or Approved equivalent	No.	131		
2.07	9U Cabinet to house equipments, such as amplifiers, splitters etc	No.	1		
<b>Total Carried Forward to Main Summary Pg.</b>					

ITEM	DESCRIPTION	UNIT	QTY	RATE (KSH)	AMOUNT (KSH)
(iv)	<b>LV SWITCHBOARD INSTALLATION &amp; EARTHING</b>				
	TAKE DELIVERY, STORE, INSTALL AND COMMISSION THE FOLLOWING:-				
2.01	Install purpose made Free-standing, fully wired front access metal clad main switchboard cubicle suitable for floor / wall mounting and manufactured in 14SWG galvanised mild steel sheet, to be finished in cream (or appropriate colour) powder coating. Wiring as shown on the schematic (the other details as per Particular Specification), complete with the following:-	Item	1		
(i)	400Amps TP/N copper busbars - KPLC supply (Sealable)				
(ii)	400Amps MCCB as mains incomer adjustable				
(iii)	Space for 1No. 3-phase KPLC Common Services meter (kW, kWh, kVA, V, I etc), 63A TP MCB				
(iv)	120No. 63A DP MCBs for the sub-main cables				
(v)	1No. 100A DP MCBs for the sub-main cables				
(vi)	Space for KPLC cut-outs including studs for mounting KPLC seals				
(vii)	Sealable studs for all cover plate screws and all necessary accessories				
(viii)	6mm perspex viewing window for each section				
(ix)	Heavy duty rubber lining for all the perspex viewing windows				
(x)	4 No. Spare ways				
<b>Total Carried Forward to Next Page</b>					

ITEM	DESCRIPTION	UNIT	QTY	RATE (KSH)	AMOUNT (KSH)
2.02	<p><b>Total B/F from Previous Pg.</b></p> <p>Earthing for the switch-board under this section comprising 25x3mm copper tape lead, 1800mm long x 15mm diameter copper earth electrode as Furse or approved equivalent complete with driving stud and tape to rod clamp, 300mm x 300mm x 300mm deep concrete inspection earth pit with removable waterproof cover, 600mm x 600mm copper earth mat, soil conditioning agents (marconite and bentonite etc) necessary to achieve earthing value below 5-Ohms and all other necessary accessories</p>	No.	1		
<b>Total Carried Forward to Main Summary Page</b>					

ITEM	DESCRIPTION	AMOUNT
<b>BLOCK TYPE B SUMMARY PAGE</b>		
1	Total Amount for Ground Floor B/F Page 21	
2	Total Amount for Typical 1st - 4th Floor B/F Page 40	
3	Total Amount for Lightning Protection B/F Page 42	
4	Total Amount for Smatv B/F Page 43	
5	Total Amount for LV Switchboard Installation and Earthing B/F Page 45	
<b>TOTAL AMOUNT FOR BILL No. 2: TYPICAL 1NO. BLOCK TYPE B CARRIED FORWARD TO PRICE COLLECTION PAGE</b>		

ITEM	DESCRIPTION	UNIT	QTY	RATE (KSH)	AMOUNT (KSH)
	<b>BILL NO. 3</b>				
i)	<b><u>EXTENAL SERVICES</u></b>				
	Supply, Install, test and Commission the following;				
	<b>STREET LIGHTING</b>				
A	Cylindrical-conical pole 8 meters with single arm and tube, in hot-dipped galvanized steel painted with anchor bolts complete with photovoltaic solar panel minimum 305Wp LED light 1x2B - 80W nominal - 24V - 4000K - >190lm/W NiMH battery 24V 4P, on top of pole,	No	75		
B	Type ML- 20m Highmast c/w 200 W flood light complete with with inbuilt charge controller, NiMH battery, automatic light sensor and a solar panel complete with all necessary wiring,fixing bracket and all other neccessary accessories	No.	6		
C	Type WL- IP65 External bulkhead fitting	No.	20		
ii)	<b>POWER HOUSE ELECTRICS</b>				
D	All lighting points wired in 1.5mm <sup>2</sup> PVC cu cables in 20mm diameterHG PVC conduit embedded in wall fabrics, roof structure and floor slabs complete with switches as shown on the contract drawings	No	20		
	<b>POWER</b>				
E	4way 63A SPN CU as SCHNEIDER or Equivalent and Approved complete with MCBs or equal and approved.	No	1		
F	All socket outlet points wired in 2.5mm <sup>2</sup> PVC cable in conduit embedded in floor slabs and in metal trunking complete with 13A twin socket outlet as shown on the drawing	No	4		
<b>Total Carried Forward to the Next Pg.</b>					

ITEM	DESCRIPTION	UNIT	QTY	RATE (KSH)	AMOUNT (KSH)
	<b>Total B/F from Previous Pg.</b>				
	<b>POWER</b>				
G	Provisions for points including laying of conduits and provision of outlet boxes for the following:				
	i) Surveillance Cameras	No	60		
	<b>DATA</b>				
H	600 x 600 x 600 concrete manhole complete with Manhole covers.	No	50		
I	100mm diameter HG PVC ducts for KPLC Ltd, laid at a depth of 600mm.	Lm.	1100		
J	Trenching to a depth of 700mm, and backfilling after laying of ducts itemised above.	Lm.	1050		
iii)	<b>PUMP ROOM ELECTRICS</b>				
K	All lighting points wired in 1.5mm <sup>2</sup> PVC cu cables in 20mm diameterHG PVC conduit embedded in wall fabrics, roof structure and floor slabs complete with switches as shown on the contract drawings	No	6		
	<b>POWER</b>				
L	Supply, install and connect 6 way TP/N distribution board for power supply in riser duct complete with 250 Amp integral isolator and MCBs as specified.	No	1		
M	All socket outlet points wired in 2.5mm <sup>2</sup> PVC cable in conduit embedded in floor slabs and in metal trunking complete with 13A twin socket outlet as shown on the drawing	No	4		
N	400A TPN isolator as KATCO or approved equivalent	No	10		
M	Submains circuit from the External Common Loads LV Board to Pump Room DB in electrical ducts comprising of 95mm <sup>2</sup> XLPE/PVC/SWA 4c + 35mm <sup>2</sup> sc ECC Copper cables laid in PVC Duct and Trays	Lm.	50		
	<b>Total Carried Forward to the Next Pg.</b>				

ITEM	DESCRIPTION	UNIT	QTY	RATE (KSH)	AMOUNT (KSH)
	<b>Total B/F from Previous Pg.</b>				
	<b><u>EXTERNAL LOADS SWITCHBOARD</u></b>				
	SUPPLY, DELIVER , INSTALL ,SET TO WORK AND COMMISSION THE FOLLOWING:-				
N	Supply and install purpose made Free-standing, fully wired front access metal clad main switchboard cubicle suitable for floor / wall mounting and manufactured in 14SWG galvanised mild steel sheet, to be finished in cream (or appropriate colour) powder coating. Wiring as shown on the schematic (the other details as per Particular Specification), complete with the following:-	No.	1		
(i)	320Amps TP/N copper busbars - KPLC supply (Sealable)				
(ii)	320Amps MCCB as mains incomer adjustable				
(iii)	Space for 1No. 3-phase KPLC Common Services meter (kW, kWh, kVA, V, I etc),				
	<b>Outgoers:</b>				
(iv)	1No. 250A TP MCCBs for the Pump Room DB				
(v)	5No. 63A TP MCCBs for the External Loads Feeder Pillars				
(vi)	Sealable studs for all cover plate screws and all necessary accessories				
(vii)	6mm perspex viewing window for each section				
(viii)	Heavy duty rubber lining for all the perspex viewing windows				
(ix)	4 No. Spare ways				
O	Feeder Pillars, 125A 6-WAY TPN Feeder Pillar with 125A TPN incomer and 10x20A SP MCBs outgoers and 3No. spareways for External power distribution to to Engineer's approval	No.	5		
P	Submains circuit from the External Common Loads LV Board to Feeder Pillars in electrical ducts comprising of 16mm <sup>2</sup> XLPE/PVC/SWA 4c + 6mm <sup>2</sup> sc ECC Copper cables laid in PVC Duct and Trays	Lm.	200		
<b>Total Carried Forward to Main Summary Page</b>					

ITEM	DESCRIPTION	UNIT	QTY	RATE (KSH)	AMOUNT (KSH)
	<b>BILL NO. 4</b>				
i)	<b><u>INCOMING POWER</u></b>				
	<b><u>KPLC RELATED WORKS</u></b>				
A	150mm diameter Heavy gauge duct for incoming underground H.V. cables with 1:3:6 concrete surround	M	1050		
B	900 x 900 x 900 concrete manhole complete with Manhole covers and Hatari( Danger) Sign indelibly engraved at the top	No	50		
C	Hatari( Danger) sign concrete slabs	No	50		
D	Attendance on Kenya Power and Lighting Co. Ltd.	Sum	1		
E	Complete Earthing system to KPLC requirements	Sum	1		
F	Any other item to complete the installation in this section.	Sum	1		
Total Carried Forward to Main Summary Page					



ITEM	DESCRIPTION	UNIT	QTY	RATE (KSH)	AMOUNT (KSH)
	<b><u>BILL NO. 5</u></b>				
	<b><u>CLUB HOUSE</u></b>				
	SUPPLY, DELIVER , INSTALL ,SET TO WORK AND COMMISSION THE FOLLOWING:-				
	<b>LIGHTING POINTS</b>				
5.01	Lighting point completely wired in 3 x 1.5mm <sup>2</sup> single core PVC insulated copper cables drawn in 20mm diameter heavy gauge PVC conduits including all accessories for one way switching, but excluding the switch and luminaire.	No.	34		
	ii) Ditto as in item No. 4.01 but for two way switching	No.	24		
5.02	10A white moulded switch plate as Crabtree, MK Logic, Clipsal E- Series or approved equivalent as follows:-				
	i) 10A one gang one way switch	No.	14		
	ii) 10A one gang two way switch	No.	4		
	iii) 10A two gang two way switch	No.	4		
5.03	<b>LIGHTING FITTINGS</b>				
	a) Circular shaped surface mounted led luminaire as Phillips Coreline Cat No. WL131V LED12S/840 PSED EL3 WH "Type N"	No.	24		
	b) Bulkhead fitting with moulded glass diffuser & Die Cast Aluminium base c/w 16W PL Lamp as Massive Sunderland Cat. No. 71410/01/31 for security lights. "Type B"	No.	10		
<b>Total Carried Forward to the Next Pg.</b>					

ITEM	DESCRIPTION	UNIT	QTY	RATE (KSH)	AMOUNT (KSH)
	<b>Total B/F from Previous Pg.</b>				
	c) 600mm x 600mm, 33 watts LED panel light fitting as Phillips CoreLine Cat. No. RC132V LED36S/840 PSU W 60L60 OC complete with Phillips LED internal driver	No.	3		
	d) 1 x 36W, 1200mm Surface mounted mirror strip HPF water proof 1P65 fluorescent fitting with diffuser as Thorn or equal and approved equivalent type "4M"	No.	4		
	e) Large decorative highbay pendant with metal die cast aluminium housing on single steel wire suspension for 70w lamps complete with prismatic polycarbonate, lamps & aluminium reflector as Thorn Glacier II or equal and approved equivalent type "B".	No.	12		
	f) 36W Suspended/Wall mounted LED linear luminaire complete with LEDs mounted on steel plate, base made of plastic polycarbonate, Diffuser "Type 4C"	No.	3		
5.04	CCTV points in designated locations for surveillance, comprising of 25mm diameter HG PVC conduits complete with draw wire and the blanking plate. Allow for draw boxes where all the conduits from each security point converge.	No.	4		
5.05	300x 300x 100mm deep 16 G galvanized adaptable box.	No.	2		
5.06	24A, 240V, 2P DB/CU mounted silent operation contactor for Switching External lights complete with all accessories and as CRABTREE CIK24 or an approved equivalent	No.	1		
5.07	Photocell control unit and wired to energize the contactors complete with a D.P override switch as THORN QPK or approved equivalent	No.	1		
	<b>Total Carried Forward to the Next Pg.</b>				

ITEM	DESCRIPTION	UNIT	QTY	RATE (KSH)	AMOUNT (KSH)
	<b>Total B/F from Previous Pg.</b>				
	<b>POWER AND SOCKET OUTLET POINTS</b>				
5.08	13A SP socket point completely wired in 3 x 2.5mm <sup>2</sup> single core PVC insulated copper cables drawn in 25mm diameter heavy gauge PVC conduits including all accessories but excluding the 13A SP switched socket outlet.	No.	8		
5.09	Socket Outlet plates i) 13A SP twin switched socket outlet as MK 2536 or equal & approved equivalent.	No.	8		
5.10	Instant shower water heater power points completely wired in 3 x 4mm <sup>2</sup> single core PVC insulated copper cables drawn in 25mm diameter heavy gauge PVC conduits including all accessories, but excluding the 40A DP connection unit	No.	2		
5.11	40A DP switched connection unit with neon indicator as MK or approved equivalent	No.	2		
5.12	Under sink water heater power points completely wired in 3 x 4mm <sup>2</sup> single core PVC insulated copper cables drawn in 25mm diameter heavy gauge PVC conduits including all accessories, but excluding the 40A DP connection unit	No.	1		
5.13	40A DP switched connection unit with neon indicator as MK or approved equivalent	No.	1		
<b>Total Carried Forward to the Next Pg.</b>					

ITEM	DESCRIPTION	UNIT	QTY	RATE (KSH)	AMOUNT (KSH)
	<b>Total B/F from Previous Pg.</b>				
5.14	Hand drier power points completely wired in 3 x 2.5mm <sup>2</sup> single core PVC insulated copper cables drawn in 25mm diameter heavy gauge PVC conduits including all accessories, but excluding the 20A DP connection unit	No.	2		
5.15	20A DP switched connection unit with neon indicator as MK or approved equivalent	No.	2		
5.16	Kitchen hood power points completely wired in 3 x 2.5mm <sup>2</sup> single core PVC insulated copper cables drawn in 25mm diameter heavy gauge PVC conduits including all accessories, but excluding the 20A DP connection unit	No.	1		
5.17	20A DP switched connection unit with neon indicator as MK or approved equivalent	No.	1		
4.18	Deep fat fryer power points completely wired in 5 x 6mm <sup>2</sup> single core PVC insulated copper cables drawn in 32mm diameter heavy gauge PVC conduits including all accessories ,but excluding the the 63A TPN isolator	No.	2		
5.19	Electric 4 burner power points completely wired in 5 x 6mm <sup>2</sup> single core PVC insulated copper cables drawn in 32mm diameter heavy gauge PVC conduits including all accessories ,but excluding the the 63A TPN isolator	No.	2		
5.20	63A TPN isolator as MK or approved equivalent	No.	4		
<b>Total Carried Forward to the Next Pg.</b>					

ITEM	DESCRIPTION	UNIT	QTY	RATE (KSH)	AMOUNT (KSH)
	<b>Total B/F from Previous Pg.</b>				
	<b>TELEPHONE, DATA AND TV POINTS POINTS</b>				
5.21	Data point comprising of draw wire in 25mm diameter Heavy Gauge PVC conduits including all accessories and blanking plate but excluding the data socket outlet.	No.	2		
5.22	6 ways 100A TPN distribution boards 'T' complete with 100A TPN integral isolator ,but excluding the MCBs ,and as Schneider Electric Acti 9 or approved equivalent.	No.	1		
5.23	<b>MCBs for item above as Schneider Electric Acti 9</b>				
	i)10 A SP MCB	No.	3		
	ii)32 A SP MCB	No.	2		
	iii)32 A TP MCB	No.	4		
	iv) Blanking plates	No.	4		
5.24	Sub-mains circuits for DB 'T' above comprising of 4 core 16mm <sup>2</sup> PVC/SWA/PVC cable drawn in 32mm diameter heavy gauge conduits for club house	LM	90		
<b>TOTAL AMOUNT FOR BILL No. 5: CLUB HOUSE CARRIED FORWARD TO GRAND SUMMARY PAGE</b>					

ITEM	DESCRIPTION	UNIT	QTY	RATE (KSH)	AMOUNT (KSH)
	<b><u>BILL NO. 6</u></b>				
	<b><u>GATE HOUSE &amp; GARBAGE RECEPTACLE</u></b>				
A.	<b><u>GUARD HOUSE</u></b>				
	SUPPLY, DELIVER , INSTALL ,SET TO WORK AND COMMISSION THE FOLLOWING:-				
	<b>LIGHTING POINTS</b>				
6.01	Lighting point completely wired in 3 x 1.5mm <sup>2</sup> single core PVC insulated copper cables drawn in 20mm diameter heavy gauge PVC conduits including all accessories for one way switching, but excluding the switch and luminaire.	No.	8		
	ii) Ditto as in item No. 5.01 but for two way switching	No.	8		
6.02	10A white moulded switch plate as Crabtree, MK Logic, Clipsal E- Series or approved equivalent as follows:-				
	i) 10A one gang one way switch	No.	6		
	ii) 10A one gang two way switch	No.	4		
6.03	<b>LIGHTING FITTINGS</b>				
	a) Circular shaped surface mounted led luminaire as Phillips Coreline Cat No. WL131V LED12S/840 PSED EL3 WH "Type N"	No.	12		
	b) Bulkhead fitting with moulded glass diffuser & Die Cast Aluminium base c/w 16W PL Lamp as Massive Sunderland Cat. No. 71410/01/31 for security lights. "Type B"	No.	4		
<b>Total Carried Forward to Next Page</b>					

ITEM	DESCRIPTION	UNIT	QTY	RATE (KSH)	AMOUNT (KSH)
	<b>Total B/F from Previous Pg.</b>				
6.04	CCTV points in designaed locations for survailance, comprising of 25mm diameter HG PVC conduits complete with draw wire and the blanking plate. Allow for draw boxes where all the conduits from each security point converge.	No.	6		
6.05	300x 300x 100mm deep 16 G galvanized adaptable box.	No.	1		
6.06	24A, 240V, 2P DB/CU mounted silent operation contactor for Switching External lights complete with all accessories and as CRABTREE CIK24 or an approved equivalent	No.	1		
6.07	Photocell control unit and wired to energize the contactors complete with a D.P override switch as THORN QPK or approved equivalent	No.	1		
	<b>POWER AND SOCKET OUTLET POINTS</b>				
6.08	13A SP socket point completely wired in 3 x 2.5mm <sup>2</sup> single core PVC insulated copper cables drawn in 25mm diameter heavy gauge PVC conduits including all accessories but excluding the 13A SP switched socket outlet.	No.	1		
6.09	Socket Outlet plates i) 13A SP twin switched socket outlet as MK 2536 or equal & approved equivalent.	No.	1		
<b>Total Carried Forward to Next Page</b>					

ITEM	DESCRIPTION	UNIT	QTY	RATE (KSH)	AMOUNT (KSH)
	<b>Total B/F from Previous Pg.</b>				
	<b>TELEPHONE, DATA AND TV POINTS POINTS</b>				
6.10	Data point comprising of draw wire in 25mm diameter Heavy Gauge PVC conduits including all accessories and blanking plate but excluding the data socket outlet.	No.	1		
6.11	6 ways 100A SPN Consumer Unit 'G' complete with 100A SPN integral isolator, but excluding the MCBs ,and as Schneider Electric Acti 9 or approved equivalent.	No.	1		
6.12	<b>MCBs for item above as Schneider Electric Acti 9 or approved equivalent</b>				
	i)10 A SP MCB	No.	1		
	ii)32 A SP MCB	No.	1		
	iii) Blanking plates	No.	4		
6.13	Sub-mains circuits for CU 'G' above comprising of 2 core 6mm <sup>2</sup> PVC/SWA/PVC cable drawn in 32mm diameter heavy gauge conduits for gate house	LM	35		
<b>TOTAL AMOUNT FOR BILL No. 6 GATE HOUSE &amp; GARBAGE RECEPTACLE CARRIED FORWARD TO GRAND SUMMARY PAGE</b>					



ITEM	DESCRIPTION	UNIT	QTY	RATE (KSH)	AMOUNT (KSH)
	<b>BILL NO. 7</b>				
7.00	<b><u>COMMUNITY CENTRE</u></b>				
	<b><u>LIGHTING POINTS, FITTINGS &amp; ACCESSORIES</u></b>				
	<b><u>Supply, Install, Connect, Test and Set to work the following:-</u></b>				
7.01	Lighting points wired in 3x1.5mm <sup>2</sup> PVC insulated single core (SC) copper cables drawn in 20mm diameter HG PVC conduit concealed in walls and or floor slabs with all accessories but excluding switch and fitting for one way switching.	No.	124		
7.02	Ditto but for two way switching.	No.	8		
7.03	Ditto but for Emergency Switching.	No.	12		
	<b><u>Supply, Install, Connect, Test and Set to work the following as marked on drawings and described in the schedule of Fittings:-</u></b>				
	<b><i>10A white moulded wide rocker switch plates:-</i></b>				
7.04	10A 1 gang 1 way switch	No.	12		
7.05	10A 2 gang 2 way switch	No.	4		
	<i>Light fittings, complete with lamps of specified wattage and appropriate colour rendering:-</i>				
7.06	Type P 1200 X 300MM 220/240V x 30 watt Warm White, 6500K Ceiling Mount. (Two LED Tubes)	No.	64		
7.07	Type D - Round Light with LED lamp	No.	60		
<b>Total Carried Forward to Next Page</b>					

ITEM	DESCRIPTION	UNIT	QTY	RATE (KSH)	AMOUNT (KSH)
	<b>Total B/F from Previous Pg.</b>				
7.08	Spherical screwneck luminaire with opal glass and 16W compact lamp as Astra, Micromark, Thorn or approved equivalent. " <b>Type BF</b> "	No.	20		
7.09	Type Exit	No.	20		
7.10	d) Bulkhead fitting with moulded glass diffuser & Die Cast Aluminium base c/w 16W PL Lamp as Massive Sunderland Cat. No. 71410/01/31 for security lights. " <b>Type S</b> "	No.	20		
7.11	Presence sensor complete with associated wiring (light and motion sensor) as Osram Duo with the following characteristics:  Operation voltage 220 - 240V 50Hz, detection area-12m dia minimum, settable light value, switch-off delay (if no motion detected), installation height - 5m minimum	No.	6		
7.12	24A, 240V, 2P DB/CU mounted silent operation contactor for Switching External lights complete with all accessories and as CRABTREE CIK24 or an approved equivalent	No.	2		
7.13	Photocell control unit and wired to energize the contactors complete with a D.P override switch as THORN QPK or approved equivalent	No.	2		
	<b><u>POWER POINTS &amp; ACCESSORIES</u></b>				
	<b>Supply, Install, connect and set to work the following:-</b>				
7.14	13A SP socket point completely wired in 3 x 2.5mm <sup>2</sup> single core PVC insulated copper cables drawn in 25mm diameter heavy gauge PVC conduits including all accessories but excluding the 13A SP switched socket outlet.	No.	60		
	Socket Outlet plates i) 13A SP twin switched socket outlet as MK 2536 or equal & approved equivalent.	No.	60		
<b>Total Carried Forward to Next Page</b>					

ITEM	DESCRIPTION	UNIT	QTY	RATE (KSH)	AMOUNT (KSH)
	<b>Total B/F from Previous Pg.</b>				
7.15	Cooker outlet power points completely wired in 3 x 6.0mm <sup>2</sup> single core PVC insulated copper cables drawn in 32mm diameter heavy gauge PVC conduits including all accessories ,but excluding the 45A DP connection unit	No.	1		
7.16	45A Moulded plate Cooker Control Unit complete with 13A fused socket outlet as MK/Crabtree or approved equivalent.	No.	1		
7.17	45A moulded plate cooker connection unit as MK/Crabtree or approved equivalent:	No.	1		
7.18	300x 300x 100mm deep 16 G galvanized adaptable box.	No.	4		
7.19	Water booster power points completely wired in 5 x 6mm <sup>2</sup> single core PVC insulated copper cables drawn in 38mm diameter heavy gauge PVC conduits including all accessories ,but excluding the the 40A TPN isolator	No.	1		
7.20	40A TPN isolator as MK or approved equivalent	No.	1		
	<b><u>ELV CABLE WAYS</u></b>				
	<b>ICT Points</b>				
7.21	Supply, install and connect data outlet point consisting of average 20 meters of 25 mm diameter concealed heavy gauge PVC conduit inclusive of conduit, couplers, draw boxes, switch boxes, draw wire and other necessary accessories but excluding face plates.	No.	20		
	<b>CCTV Points</b>				
7.22	Supply, install and connect CCTV outlet point consisting of average 20 meters of 25 mm diameter concealed heavy gauge PVC conduit inclusive of conduit, couplers, draw boxes, switch boxes, draw wire and other necessary accessories.	No.	10		
<b>Total Carried Forward to Next Page</b>					

ITEM	DESCRIPTION	UNIT	QTY	RATE (KSH)	AMOUNT (KSH)
	<b>Total B/F from Previous Pg.</b>				
	<b>Fire Alarm Points</b>				
7.23	Outlets for fire Alarm points drawn in 25mm diameter heavy gauge PVC conduits concealed in wall and floor slabs including all conduit accessories and draw wire but excluding cabling and detectors	No.	10		
	<b><u>POWER DISTRIBUTION</u></b>				
	<b>Supply, Install, connect and set to work the following:-</b>				
7.24	8 ways 100A TPN distribution boards 'T' complete with 100A TPN integral isolator ,but excluding the MCBs ,and as Schneider Electric Acti 9 or approved equivalent.	No.	1		
	i)10 A SP MCB	No.	10		
	ii) 32 A SP MCB	No.	10		
	iii) 40 A SP MCB	No.	1		
	iv) 32 A TP MCB	No.	1		
	v) Blanking plates	No.	4		
	vi)Earthing of the Distribution Board above	Item.	4		
7.25	Sub-mains circuits for DB 'T' above comprising of 4 core 25mm <sup>2</sup> PVC/SWA/PVC cable drawn in cable tray/ 50mm diameter heavy gauge conduits and running from the Lv switchboard	LM	150		
	200mm x 50mm galvanised metallic cable tray (Telecom, DTV, Internet Cables) gauge 14 c/w all mounting accessories bends, rawl bolts, threaded bolts, brackets,	LM.	200		
	200mm x 50mm galvanised metallic cable tray (Power Cables) gauge 14 c/w all mounting accessories bends, rawl bolts, threaded bolts, brackets,	LM.	200		
<b>TOTAL AMOUNT FOR BILL No. 7 COMMUNITY CENTRE CARRIED FORWARD TO GRAND SUMMARY PAGE</b>					

ITEM	DESCRIPTION	UNIT	QTY	RATE (KSH)	AMOUNT (KSH)
	<b>BILL NO. 8</b>				
8.00	<b><u>SCHOOL</u></b>				
	<b><u>LIGHTING POINTS, FITTINGS &amp; ACCESSORIES</u></b>				
	<b><u>Supply, Install, Connect, Test and Set to work the following:-</u></b>				
8.01	Lighting points wired in 3x1.5mm <sup>2</sup> PVC insulated single core (SC) copper cables drawn in 20mm diameter HG PVC conduit concealed in walls and or floor slabs with all accessories but excluding switch and fitting for one way switching.	No.	220		
8.02	Ditto but for two way switching.	No.	8		
8.03	Ditto but for Emergency Switching.	No.	12		
	<b><u>Supply, Install, Connect, Test and Set to work the following as marked on drawings and described in the schedule of Fittings:-</u></b>				
	<b><i>10A white moulded wide rocker switch plates:-</i></b>				
8.04	10A 1 gang 1 way switch	No.	40		
8.05	10A 2 gang 2 way switch	No.	12		
	<b><i>Light fittings, complete with lamps of specified wattage and appropriate colour rendering:-</i></b>				
8.06	Type P 1200 X 300MM 220/240V x 30 watt Warm White, 6500K Ceiling Mount. (Two LED Tubes)	No.	120		
<b>Total Carried Forward to Next Page</b>					

ITEM	DESCRIPTION	UNIT	QTY	RATE (KSH)	AMOUNT (KSH)
	<b>Total B/F from Previous Pg.</b>				
8.07	Type D - Round Light with LED lamp	No.	100		
8.08	Spherical screwneck luminaire with opal glass and 16W compact lamp as Astra, Micromark, Thorn or approved equivalent. <b>"Type BF"</b>	No.	40		
8.07	Type Exit	No.	30		
8.09	d) Bulkhead fitting with moulded glass diffuser & Die Cast Aluminium base c/w 16W PL Lamp as Massive Sunderland Cat. No. 71410/01/31 for security lights. <b>"Type S"</b>	No.	30		
8.10	Presence sensor complete with associated wiring (light and motion sensor) as Osram Duo with the following characteristics: Operation voltage 220 - 240V 50Hz, detection area-12m dia minimum, settable light value, switch-off delay (if no motion detected), installation height - 5m minimum	No.	8		
8.11	24A, 240V, 2P DB/CU mounted silent operation contactor for Switching External lights complete with all accessories and as CRABTREE CIK24 or an approved equivalent	No.	2		
8.12	Photocell control unit and wired to energize the contactors complete with a D.P override switch as THORN QPK or approved equivalent	No.	2		
<b>Total Carried Forward to Next Page</b>					

ITEM	DESCRIPTION	UNIT	QTY	RATE (KSH)	AMOUNT (KSH)
	<b>Total B/F from Previous Pg.</b>				
	<b><u>POWER POINTS &amp; ACCESSORIES</u></b> <b>Supply, Install, connect and set to work the following:-</b>				
8.13	13A SP socket point completely wired in 3 x 2.5mm <sup>2</sup> single core PVC insulated copper cables drawn in 25mm diameter heavy gauge PVC conduits including all accessories but excluding the 13A SP switched socket outlet.	No.	100		
	Socket Outlet plates i) 13A SP twin switched socket outlet as MK 2536 or equal & approved equivalent.	No.	100		
8.14	Cooker outlet power points completely wired in 3 x 6.0mm <sup>2</sup> single core PVC insulated copper cables drawn in 32mm diameter heavy gauge PVC conduits including all accessories ,but excluding the 45A DP connection unit	No.	4		
8.15	45A Moulded plate Cooker Control Unit complete with 13A fused socket outlet as MK/Crabtree or approved equivalent.	No.	4		
8.16	45A moulded plate cooker connection unit as MK/Crabtree or approved equivalent:	No.	4		
8.17	300x 300x 100mm deep 16 G galvanized adaptable box.	No.	8		
8.18	Water booster power points completely wired in 5 x 6mm <sup>2</sup> single core PVC insulated copper cables drawn in 38mm diameter heavy gauge PVC conduits including all accessories ,but excluding the the 40A TPN isolator	No.	2		
8.19	40A TPN isolator as MK or approved equivalent	No.	2		
<b>Total Carried Forward to Next Page</b>					

ITEM	DESCRIPTION	UNIT	QTY	RATE (KSH)	AMOUNT (KSH)
	<b>Total B/F from Previous Pg.</b>				
	<b><u>ELV CABLE WAYS</u></b>				
	<b>ICT Points</b>				
8.20	Supply, install and connect data outlet point consisting of average 20 meters of 25 mm diameter concealed heavy gauge PVC conduit inclusive of conduit, couplers, draw boxes, switch boxes, draw wire and other necessary accessories but excluding face plates.	No.	60		
	<b>CCTV Points</b>				
8.21	Supply, install and connect CCTV outlet point consisting of average 20 meters of 25 mm diameter concealed heavy gauge PVC conduit inclusive of conduit, couplers, draw boxes, switch boxes, draw wire and other necessary accessories.	No.	20		
	<b>Fire Alarm Points</b>				
8.22	Outlets for fire Alarm points drawn in 25mm diameter heavy gauge PVC conduits concealed in wall and floor slabs including all conduit accessories and draw wire but excluding cabling and detectors	No.	50		
	<b><u>POWER DISTRIBUTION</u></b>				
	<b>Supply, Install, connect and set to work the following:-</b>				
8.23	8 ways 100A TPN distribution boards 'T' complete with 100A TPN integral isolator ,but excluding the MCBs ,and as Schneider Electric Acti 9 or approved equivalent.	No.	4		
	i)10 A SP MCB	No.	16		
	ii) 32 A SP MCB	No.	16		
	iii) 40 A SP MCB	No.	4		
	iv) 32 A TP MCB	No.	4		
	v) Blanking plates	No.	8		
	vi)Earthing of the Distribution Board above	Item.	4		
	<b>Total Carried Forward to Next Page</b>				



ITEM	DESCRIPTION	UNIT	QTY	RATE (KSH)	AMOUNT (KSH)
	<p><b>Total B/F from Previous Pg.</b></p> <p>8.24 Sub-mains circuits for DB 'T' above comprising of 4 core 25mm<sup>2</sup> PVC/SWA/PVC cable drawn in cable tray/ 50mm diameter heavy gauge conduits and running from the Lv switchboard</p> <p>8.25 200mm x 50mm galvanised metallic cable tray (Telecom, DTV, Internet Cables) gauge 14 c/w all mounting accessories bends, rawl bolts, threaded bolts, brackets,</p> <p>8.26 200mm x 50mm galvanised metallic cable tray (Power Cables) gauge 14 c/w all mounting accessories bends, rawl bolts, threaded bolts, brackets,</p>	LM	200		
<b>TOTAL AMOUNT FOR BILL No. 8 SCHOOL CARRIED FORWARD TO GRAND SUMMARY PAGE</b>					

ITEM NO.	DESCRIPTION	UNIT	QTY	RATE KShs	AMOUNT KShs
	<b>BILL NO. 9</b>				
	<b>MARKET CENTER</b>				
<b>A.</b>	<b>GROUND FLOOR</b>				
	SUPPLY, DELIVER , INSTALL ,SET TO WORK AND COMMISSION THE FOLLOWING:-				
	<b>LIGHTING POINTS</b>				
9.01	Lighting point completely wired in 3 x 1.5mm <sup>2</sup> single core PVC insulated copper cables drawn in 20mm diameter heavy gauge PVC conduits including all accessories for one way switching, but excluding the switch and luminaire.	No.	69		
	ii) Ditto as in item No. 6.01 but for two way switching	No.	25		
9.02	10A white moulded switch plate as Crabtree, MK Logic, Clipsal E- Series or approved equivalent as follows:-				
	i) 10A one gang one way switch	No.	10		
	ii) 10A one gang two way switch	No.	24		
	iii) 10A two gang two way switch	No.	8		
9.03	<b>LIGHTING FITTINGS</b>				
	a) Circular shaped surface mounted led luminaire as Phillips Coreline Cat No. WL131V LED12S/840 PSED EL3 WH <b>"Type DL1"</b>	No.	4		
	b) Bulkhead fitting with moulded glass diffuser & Die Cast Aluminium base c/w 16W PL Lamp as Massive Sunderland Cat. No. 71410/01/31 for security lights. <b>"Type G"</b>	No.	13		
	c) 600mm x 600mm, 33 watts LED panel light fitting as Phillips CoreLine Cat. No. RC132V LED36S/840 PSU W 60L60 OC complete with Phillips LED internal driver	No.	4		
	d) 1 x 36W, 1200mm Surface mounted mirror strip LED water proof 1P65 fluorescent fitting with diffuser as Thorn or equal and approved equivalent <b>type "4M"</b>	No.	2		
	e) 36W Suspended/Wall mounted LED linear luminaire complete with LEDs mounted on steel plate, base made of plastic polycarbonate, Diffuser <b>"Type 4C"</b>	No.	64		
	f) Self -contained single sided LED exit sign with for non-maintained emergency lighting for 3 hour duration as Thorn or approved equivalent.	No.	2		
	<b>TOTAL CARRIED FORWARD TO NEXT PAGE</b>				

ITEM NO.	DESCRIPTION	UNIT	QTY	RATE KShs	AMOUNT KShs
	<b>TOTAL BROUGHT FORWARD FROM PREVIOUS PAGE</b>				
9.04	CCTV points in designated locations for surveillance, comprising of 25mm diameter HG PVC conduits complete with draw wire and the blanking plate. Allow for draw boxes where all the conduits from each security point converge.	No.	5		
9.05	300x 300x 100mm deep 16 G galvanized adaptable box.	No.	4		
9.06	24A, 240V, 2P DB/CU mounted silent operation contactor for Switching External lights complete with all accessories and as CRABTREE CIK24 or an approved equivalent	No.	2		
9.07	Photocell control unit and wired to energize the contactors complete with a D.P override switch as THORN QPK or approved equivalent	No.	2		
	<b>POWER AND SOCKET OUTLET POINTS</b>				
9.08	13A SP socket point completely wired in 3 x 2.5mm <sup>2</sup> single core PVC insulated copper cables drawn in 25mm diameter heavy gauge PVC conduits including all accessories but excluding the 13A SP switched socket outlet.	No.	34		
9.09	Socket Outlet plates i) 13A SP twin switched socket outlet as MK 2536 or equal & approved equivalent.	No.	34		
9.10	Hand drier power points completely wired in 3 x 2.5mm <sup>2</sup> single core PVC insulated copper cables drawn in 25mm diameter heavy gauge PVC conduits including all accessories, but excluding the 20A DP connection unit	No.	2		
9.11	20A DP switched connection unit with neon indicator as MK or approved equivalent	No.	2		
	<b>TOTAL CARRIED FORWARD TO NEXT PAGE</b>				

ITEM NO.	DESCRIPTION	UNIT	QTY	RATE KShs	AMOUNT KShs
	<b>TOTAL BROUGHT FORWARD FROM PREVIOUS PAGE</b>				
	<b>TELEPHONE, DATA AND TV POINTS</b>				
9.12	Data point comprising of draw wire in 25mm diameter Heavy Gauge PVC conduits including all accessories and blanking plate but excluding the data socket outlet.	No.	5		
9.13	DTV Socket point comprising of draw wire in 25mm diameter Heavy Gauge PVC conduits including all accessories but excluding the DTV socket outlet.	No.	4		
9.14	15 ways 200A TPN distribution boards 'T' complete with 200A TPN integral isolator ,but excluding the MCBs ,and as Schneider Electric Acti 9 or approved equivalent.	No.	1		
9.15	<b>MCBs for item above as Schneider Electric Acti 9</b>				
	i)10 A SP MCB	No.	30		
	ii)32 A SP MCB	No.	12		
	iii)32 A TP MCB	No.	5		
	iv) Blanking plates	No.	20		
6.16	Sub-mains circuits for DB 'M' above comprising of 4 core 50mm <sup>2</sup> PVC/SWA/PVC cable drawn in 32mm diameter heavy gauge conduits for social hall	LM	150		
	<b>TOTAL CARRIED FORWARD TO NEXT PAGE</b>				

ITEM NO.	DESCRIPTION	UNIT	QTY	RATE KShs	AMOUNT KShs
	<b>TOTAL BROUGHT FORWARD FROM PREVIOUS PAGE</b>				
	<b>MARKET CENTER</b>				
<b>B.</b>	<b>FIRST FLOOR</b>				
	SUPPLY, DELIVER , INSTALL ,SET TO WORK AND COMMISSION THE FOLLOWING:-				
	<b>LIGHTING POINTS</b>				
9.17	Lighting point completely wired in 3 x 1.5mm <sup>2</sup> single core PVC insulated copper cables drawn in 20mm diameter heavy gauge PVC conduits including all accessories for one way switching, but excluding the switch and luminaire.	No.	56		
	ii) Ditto as in item No. 6.17 but for two way switching	No.	15		
9.18	10A white moulded switch plate as Crabtree, MK Logic, Clipsal E- Series or approved equivalent as follows:-				
	i) 10A one gang one way switch	No.	8		
	ii) 10A one gang two way switch	No.	6		
	iii) 10A two gang two way switch	No.	8		
9.19	<b>LIGHTING FITTINGS</b>				
	a) Circular shaped surface mounted led luminaire as Phillips Coreline Cat No. WL131V LED12S/840 PSED EL3 WH "Type DL1	No.	10		
	b) 600mm x 600mm, 33 watts LED panel light fitting as Phillips CoreLine Cat. No. RC132V LED36S/840 PSU W 60L60 OC complete with Phillips LED internal driver	No.	6		
	c) 1 x 36W, 1200mm Surface mounted mirror strip LED water proof 1P65 fluorescent fitting with diffuser as Thorn or equal and approved equivalent <b>type "4M"</b>	No.	2		
	d) 36W Suspended/Wall mounted LED linear luminaire complete with LEDs mounted on steel plate, base made of plastic polycarbonate, Diffuser "Type 4C"	No.	16		
	e) Self -contained single sided LED exit sign with for non-maintained emergency lighting for 3 hour duration as Thorn or approved equivalent.	No.	2		
	<b>POWER AND SOCKET OUTLET POINTS</b>				
9.20	13A SP socket point completely wired in 3 x 2.5mm <sup>2</sup> single core PVC insulated copper cables drawn in 25mm diameter heavy gauge PVC conduits including all accessories but excluding the 13A SP switched socket outlet.	No.	36		
9.21	Socket Outlet plates				
	i) 13A SP twin switched socket outlet as MK 2536 or equal & approved equivalent.	No.	36		
9.22	Hand drier power points completely wired in 3 x 2.5mm <sup>2</sup> single core PVC insulated copper cables drawn in 25mm diameter heavy gauge PVC conduits including all accessories, but excluding the 20A DP connection unit	No.	1		
9.23	20A DP switched connection unit with neon indicator as MK or approved equivalent	No.	1		
	<b>TOTAL CARRIED FORWARD TO NEXT PAGE</b>				

ITEM NO.	DESCRIPTION	UNIT	QTY	RATE KShs	AMOUNT KShs
	<b>TOTAL BROUGHT FORWARD FROM PREVIOUS PAGE</b>				
	<b>TELEPHONE, DATA AND TV POINTS</b>				
9.24	Data point comprising of draw wire in 25mm diameter Heavy Gauge PVC conduits including all accessories and blanking plate but excluding the data socket outlet.	No.	8		
9.25	DTV Socket point comprising of draw wire in 25mm diameter Heavy Gauge PVC conduits including all accessories but excluding the DTV socket outlet.	No.	1		
9.26	12 ways 100A SPN Consumer Unit 'C' complete with 100A SPN integral isolator ,but excluding the MCBs ,and as Schneider Electric Acti 9 or approved equivalent for common services.	No.	1		
9.27	<b>MCBs for item above as Schneider Electric Acti 9</b>				
	i)10 A SP MCB	No.	6		
	ii)20 A SP MCB	No.	1		
	iii)32 A SP MCB	No.	4		
	iv) Blanking plates	No.	1		
9.28	Sub-mains circuits for CU 'C ' above comprising of 3 x 10mm <sup>2</sup> single core PVC insulated copper cables drawn in 32mm heavy gauge conduits and running from common distribution board.	LM	25		
9.29	300x 300x 100mm deep 16 G galvanized adaptable box.	No.	2		
	<b>TOTAL CARRIED FORWARD TO NEXT PAGE</b>				

ITEM NO.	DESCRIPTION	UNIT	QTY	RATE KShs	AMOUNT KShs
	<b>TOTAL BROUGHT FORWARD FROM PREVIOUS PAGE</b>				
	<b><u>MARKET CENTER</u></b>				
<b>C.</b>	<b><u>EARTHING AND LIGHTNING PROTECTION</u></b>				
	SUPPLY, DELIVER , INSTALL ,SET TO WORK AND COMMISSION THE FOLLOWING:-				
	<b>Air Termination</b>				
9.30	2000mm x15mmØ multiple point pure copper Air Rods/ Termination with spikes as Furse Part No. RA240 or approved equivalent	No.	2		
9.31	Copper Air Rod Base as Furse Part No. SD105-H or approved equivalent	No.	2		
9.32	Copper Junction Clamps for copper tape as Furse Part No. CN105-H or approved equivalent	No.	2		
9.33	25mm x 3mm Tinned Copper Tape as Furse TC230 or approved equivalent	Lm.	120		
9.34	<b>Down Conductor</b>				
	25mm x 3mm Tinned Copper Tape as Furse TC230 or approved equivalent	Lm.	80		
9.35	Screwdown copper test clamp as Furse CT305 or approved equivalent	No.	2		
9.36	38mm Ø HG PVC conduits for drawing the down conductor above.	Lm.	10		
9.37	<b>Earth Termination</b>				
	15mm Ø, 1500mm long solid copper earth rod c/w driving stud, coupling, and spike as Furse RC011 or approved equivalent	No	2		
9.38	Earth rod to tape clamp type A as Furse CR108 or approved equivalent	No.	2		
9.39	Concrete inspection earth pit Cat. No. PT 005 with 5 hole earth bar as Furse Cat. No. PT 006.	No.	2		
9.40	600mm x 600mm copper earth mat made from 25mm x 3mm copper tape at 300mm spacing, buried to permanent moisture level and complete with all clamps and 6m long 25mm x 3mm copper tape clamped to the down conductor, soil conditioning agents (marconite or bentonite) as necessary to achieve earthing resistance value below 10-Ohms	Lot	1		
9.41	Allow for earthing tests for the above and submission of the report to the engineer to BS7671 & BS62305 standards	No.	1		
9.42	<b>Bonding</b> Bonding and clamping to all metal work including water pipes, gas pipes, hand-rails, smatv system, window frames, cladding, metal roof etc. and the main earth for the building.	Item	1		
	<b>TOTAL AMOUNT FOR BILL No. 9 MARKET CARRIED FORWARD TO GRAND SUMMARY PAGE</b>				

**PROPOSED BUNGOMA AFFORDABLE HOUSING PROJECT**

**ELECTRICAL INSTALLATIONS BILL OF QUANTITIES**

**GRAND SUMMARY PAGE**

ITEM	DESCRIPTION	Unit	Qty	RATE (KSHS)	AMOUNT (KSHS)
1	SUMMARY FOR INCOMING POWER & KPLC RELATED COSTS	Lot	1		
2	SUMMARY FOR ELECTRICAL SERVICES FOR AFFORDABLE HOUSING BLOCK TYPE A	No	9		
3	SUMMARY FOR ELECTRICAL SERVICES FOR AFFORDABLE HOUSING BLOCK TYPE B	No	9		
4	SUMMARY FOR EXTERNAL ELECTRICS	No	1		
5	SUMMARY FOR ELECTRICAL SERVICES FOR CLUB HOUSE	Lot	1		
6	SUMMARY FOR ELECTRICAL SERVICES FOR GATE HOUSE	Lot	2		
7	SUMMARY FOR ELECTRICAL SERVICES FOR COMMUNITY CENTER	Lot	1		
8	SUMMARY FOR ELECTRICAL SERVICES FOR SCHOOL	Lot	1		
9	SUMMARY FOR ELECTRICAL SERVICES FOR MARKET	Lot	1		
<b>TOTALS FOR ELECTRICAL INSTALLATION SERVICES FOR PROPOSED BUNGOMA AFFORDABLE HOUSING PROJECT</b>					

Amount in Words: Kenya Shillings.....

.....

Official Stamp & Address:.....

.....

Tenderer's Signature:.....Date:.....

Witness' Name:.....Witness' Signature:.....

Address:.....

Date:.....



ITEM	DESCRIPTION	UNIT	QTY	RATE	AMOUNT
A	<p style="text-align: center;"><b>ELECTRICAL INSTALLATIONS</b></p> <p>TOTALS FOR ELECTRICAL INSTALLATION SERVICES (Brought forward from Electrical Works BoQ)</p> <p><b><u>NB:</u></b> <i>Omissions/Exclusions as indicated on the Summary Page moved to Main Works Provisional Sums</i></p>	SUM	1		
	<b>TOTAL FOR ELECTRICAL INSTALLATIONS CARRIED TO GRAND SUMMARY</b>				

**PROVISIONAL SUMS & PRIME COST  
SUMS**

ITEM	DESCRIPTION	UNIT	QTY	RATE	AMOUNT
<b><u>PRIME COST SUMS</u></b>					
<b><u>Ground Breaking &amp; Project Launch</u></b>					
A	Allow a prime cost of Five Hundred Thousand Only (KSHs. 500,000) for ground breaking, project launch, commissioning and project handover	SUM	1	500,000	500,000
B	Allow for profits and overheads	%			
C	Allow for attendance	Sum			
<b><u>Marketing and sales support</u></b>					
D	Allow a prime cost of One Million (KSHs. 1,000,000) for Marketing and sales support to Boma Yangu	SUM	1	1,000,000	1,000,000
E	Allow for profits and overheads	%			
F	Allow for attendance	Sum			
<b><u>Renderers and Printing</u></b>					
G	Allow a prime cost of Five Hundred Thousand (KSHs. 500,000) for preparation of renderers and printing	SUM	1	500,000	500,000
H	Allow for profits and overheads	%			
J	Allow for attendance	Sum			
<b><u>PROVISIONAL SUMS</u></b>					
K	Clothes Drying Areas	Item		850,000	850,000
L	BasketBall Court	Item		1,500,000	1,500,000
M	Landscaping	Item		5,100,000	5,100,000
N	Retaining Walls and Existing Ground Improvements	Item		17,000,000	17,000,000
P	Internal & External Signage	Item		5,100,000	5,100,000
Q	Playing Fields	Item		5,000,000	5,000,000
<b>TOTALS FOR PROVISIONAL &amp; PRIME COST SUMS CARRIED TO GRAND SUMMARY</b>				<b>Kshs</b>	

<b><u>ELECTRICAL INSTALLATIONS PROVISIONAL SUMS / EXCLUSIONS</u></b>					
A	Supply, Installation and Commissioning of lifts to Apartment Blocks	SUM	1	198,000,000	198,000,000
B	Supply, Installation and Commissioning of Backup Generators	SUM	1	10,000,000	10,000,000
C	Supply, Installation and Commissioning of CCTV Installations	SUM	1	18,000,000	18,000,000
D	Fabrication, Supply and commissioning of LV Switchboards Distribution Boards	SUM	1	30,082,500	30,082,500
E	Capital Contribution to KPLC For Power Connection	SUM	1	60,165,000	60,165,000
<b><u>MECHANICAL INSTALLATIONS PROVISIONAL SUMS / EXCLUSIONS</u></b>					
G	Supply only of Sanitary Fittings	SUM	1	40,727,200	40,727,200
H	Supply & Installations of Water Booster Pumps	SUM	1	8,400,000	8,400,000
J	Supply of GRP Roof Level Water Tanks	SUM	1	36,500,000	36,500,000
K	Hose Reel Pumps	SUM	1	3,800,000	3,800,000
L	Borehole Drilling & Equipping	SUM	1	4,500,000	4,500,000
M	External Reticulation Borehole Water	SUM	1	101,800	101,800.00
N	External Reticulation Council Water	SUM	1	131,800	131,800
p	LPG External Reticulation Provision	SUM	1	1,200,000	1,200,000
<b>TOTAL FOR SERVICES INSTALLATIONS PROVISIONAL SUM CARRIED TO GRAND SUMMARY</b>					

# **GRAND SUMMARY**

**AFFORDABLE HOUSING PROGRAMME**  
**PROPOSED CONSTRUCT + FINANCE OF BUNGOMA SMART CITY AFFORDABLE HOUSING**  
**& MIXED USE DEVELOPMENT AND ASSOCIATED INFRASTRUCTURE IN BUNGOMA TOWN**  
**BUNGOMA COUNTY**

**GRAND SUMMARY**

ITEM	DESCRIPTION	PAGE	FOR TENDERER USE ONLY	FOR OFFICIAL USE
1.00	PARTICULAR PRELIMINARIES			
2.00	GENERAL PRELIMINARIES			
3.00	PROJECT PROVISIONS			
4.00	DEMOLITIONS			
5.00	BUILDERS WORK BLOCK TYPE A			
6.00	BUILDERS WORK BLOCK TYPE B			
7.00	CLUB HOUSE			
8.00	KINDERGATTEN			
9.00	MARKET			
10.00	SOCIAL HALLS			
11.00	PRIMARY SCHOOL			
12.00	POWER HOUSES			
13.00	GUARD HOUSES			
14.00	GARBAGE RECEPTACLES			
15.00	BOUNDARY WALLING			
16.00	CIVIL WORKS - ROADS			
17.00	CIVIL WORKS - SEWER			
18.00	UNDERGROUND WATER TANK			
19.00	PROVISIONAL SUMS & P C SUMS			
20.00	SERVICES INSTALLATION PROVISIONAL SUMS			
21.00	MECHANICAL INSTALLATION WORKS			
22.00	ELECTRICAL INSTALLATION WORKS			
	<b>SUB-TOTAL</b>			
	ADD CONTINGENCY (5%)			
	Less: CONTRACTORS TENDER DISCOUNT			
	<b>GRAND TOTAL CARRIED TO FORM OF TENDER (VAT INCLUSIVE)</b>		<b>KSHS</b>	

AMOUNT: KSHS .....

AMOUNT IN WORDS : KENYA SHILLINGS .....

.....

.....

.....

TENDERER'S NAME .....

ADDRESS .....

DATE .....

TENDERER'S SIGNATURE .....

WITNESS'S NAME.....

ADDRESS .....

DATE .....

WITNESS SIGNATURE.....

**PROPOSED CONSTRUCTION OF AFFORDABLE HOUSING AND ASSOCIATED SOCIAL INFRASTRUCTURE**

**COST PER SQM CALCULATION**

<b>1.0</b>	<b><u>CONSTRUCTION COST</u></b>		
		<b>Amount</b>	
1.1	Total Tender Sum (A)	Kshs .....	
<b>2.0</b>	<b><u>TENDER SUM EXCLUSIONS</u></b>	<b><u>Amount</u></b>	<b><u>Total</u></b>
2.1	Boundary Wall		
2.2	Civil works - Roads & Parking		
2.3	Underground/Surface Water Tank		
2.4	Civil works -sewer reticulation		
2.5	Provisional sums& prime cost sums		
2.6	Project Provisions		
<b>2.7</b>	<b>Services Installations provisonal sums</b>		
	i) Backup Generators		
	ii) CCTV Installations		
	iii) LV Switchboards Distribution Boards		
	iv) KPLC For Power Connection		
	v) Water Booster Pumps		
	vi) GRP Roof Level Water Tanks		
	vii) Hose Reel Pumps		
	viii) Borehole Drilling & Equiping		
	ix) External Reticulation Borehole Water		
	x) External Reticulation Council Water		
	xi) LPG External Reticulation Provision		
	<b>Total Exclusions (B)</b>	<b>Kshs</b>	<b>-</b>
	<b>Total Project Cost Less Exclusions (C = A-B)</b>		<b>-</b>
<b>3.0</b>	<b><u>COST PER SQM CALCULATION</u></b>		
3.1	Total Tender Sum (A)		
3.2	Total Project Cost Less Exclusions (C.)		
3.3	Gross Built up Area (D) <i>(Brought forward from project data sheet)</i>	.....	Sqm
3.4	<b>Built up Area Cost per Sqm ( C/D )</b>	Kshs .....	Per Sqm
3.5	<b>Overall Cost per Sqm (A/D)</b>	Kshs .....	Per Sqm



# REPUBLIC OF KENYA



## MINISTRY OF LANDS, PUBLIC WORKS, HOUSING AND URBAN DEVELOPMENT STATE DEPARTMENT OF HOUSING AND URBAN DEVELOPMENT

### ADDENDUM

### CONSTRUCTION DRAWINGS (ARCHITECTURAL & STRUCTURAL)

### FOR

### PROPOSED CONSTRUCTION OF BUNGOMA SMART CITY AFFORDABLE HOUSING AND MIXED- USED DEVELOPMENT IN BUNGOMA TOWN, BUNGOMA COUNTY

Ministry of Lands, Public Works, Housing and Urban Development

State Department for Housing and Urban Development,

P.O Box 30119-00100 Nairobi,

Kenya Tel: +254-020-2713833

# **ARCHITECTURAL DRAWINGS**

---

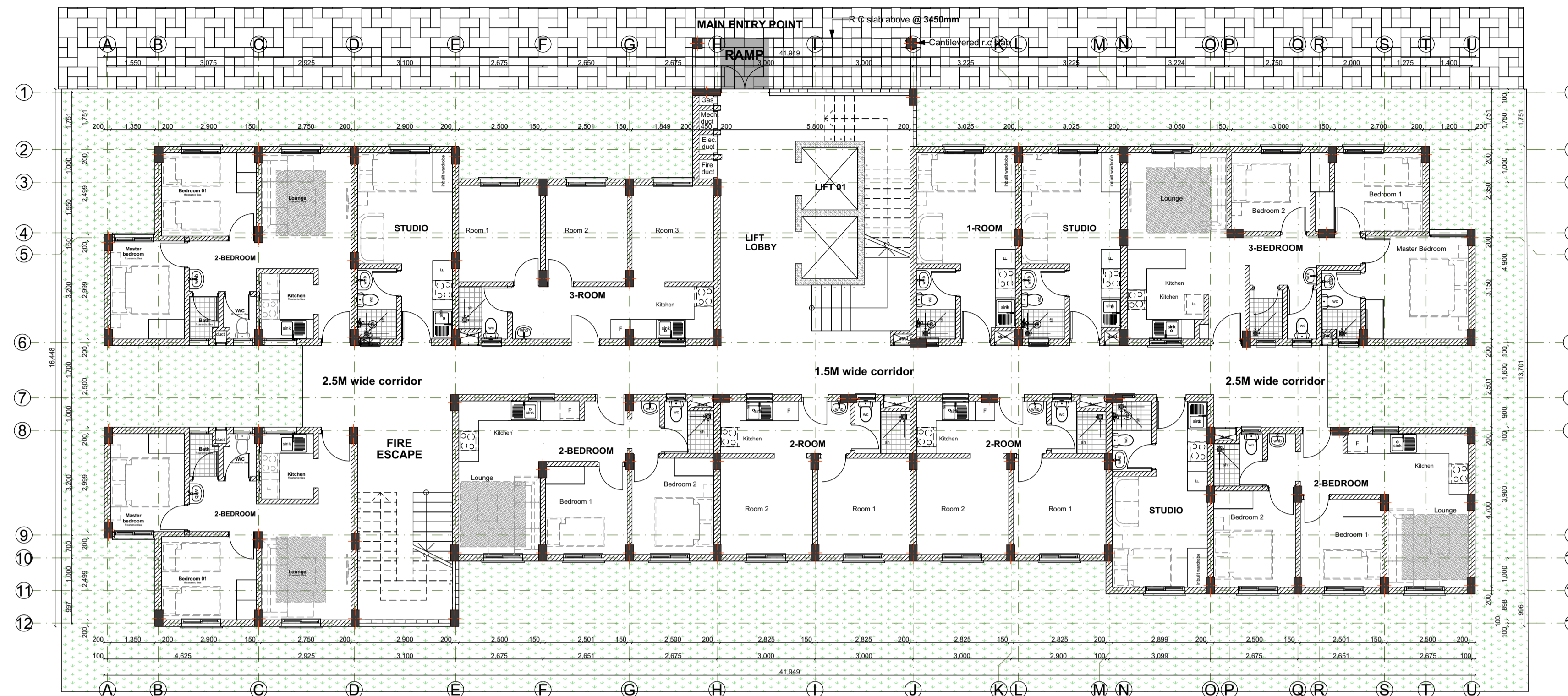

PROPOSED REVISED TYPICAL SOCIAL+ AFFORDABLE UNITS BLOCK TYPE A\_GROUND FLOOR PLAN

UNIT BREAK DOWN		UNIT BREAK DOWN			
1_ROOM	2_ROOM	3_ROOM	STUDIO	2_BEDROOM	3_BEDROOM
1	2	1	3	4	1

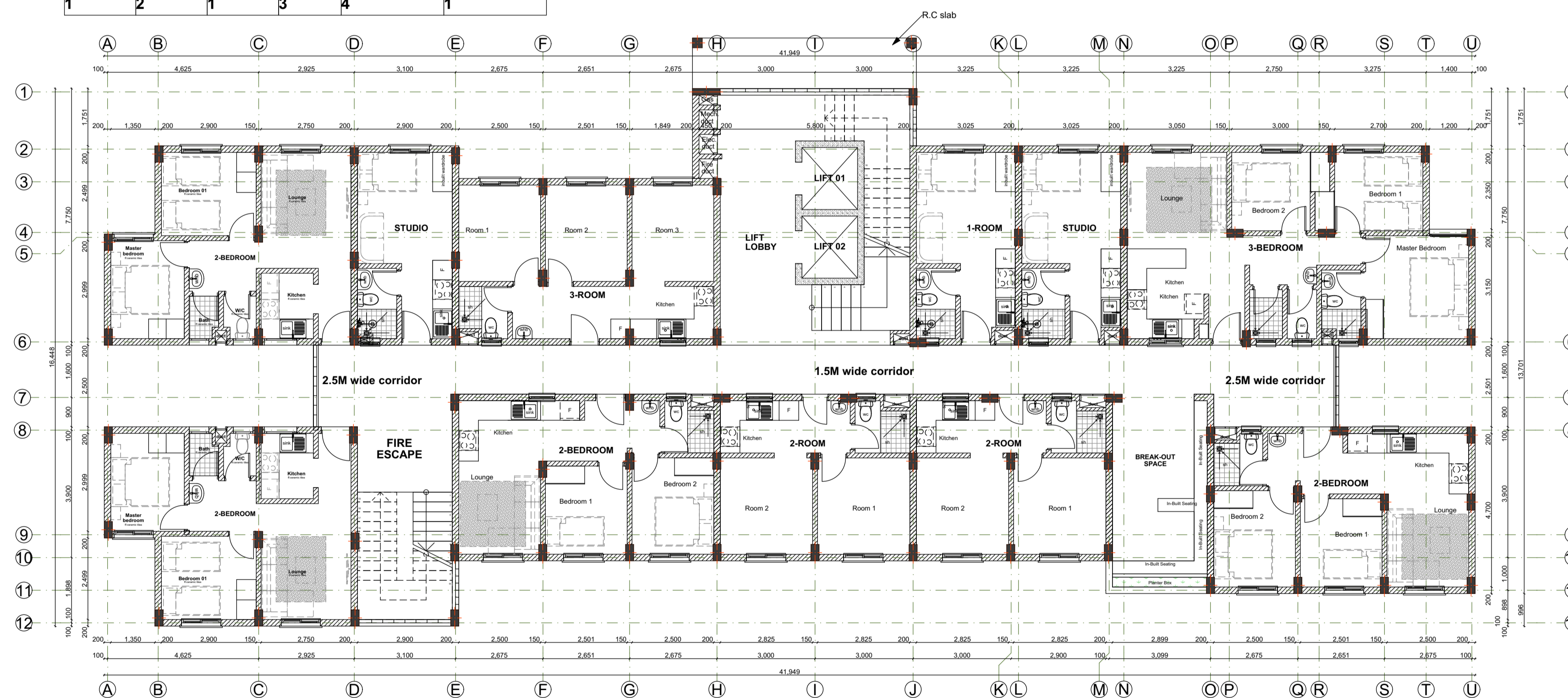

PROPOSED TYPICAL SOCIAL+ AFFORDABLE UNITS BLOCK TYPE A\_TYPICAL 1ST FLOOR PLAN

UNIT BREAK DOWN		UNIT BREAK DOWN			
1_ROOM	2_ROOM	3_ROOM	STUDIO	2_BEDROOM	3_BEDROOM
1	2	1	2	4	1

**GENERAL NOTES**

1. This drawing to be read in conjunction with Engineers' drawings.
2. All dimensions are in mm unless otherwise specified.
3. Drawings are not to be scaled. Only figured dimensions should be used.
4. The contractor must check and verify all dimensions before commencement of work and if necessary confirm with the architect.

**CONSTRUCTION**

Approved anti-termite treatment & 1000 gauge polythene sheeting cover to be provided under all ground floor concrete slab on compacted hardcore to approval.  
DPC to be 3ply bituminous felt to be provided under all walls.

**STRUCTURAL**

1. All Black cotton soil to be removed from below all building and paved surfaces
2. All reinforced concrete work will be in accordance with structural drawings.
3. Foundation depths to be determined on site to S.E approval
4. All walls less than 200mm thick to be reinforced with hoop iron at every alternate course.
5. All adjacent R.C work and masonry walls to be tied with strap irons at every course

**MECHANICAL**

1. All Plumbing and Drainage Work to comply with specifications
2. S.V.P denotes soil vent pipe and to be provided at the head of the drainage
3. Where drainage is shown under driveways and slabs, to be encased in 150mm thick concrete surround.
4. All underground foul and waste drain pipes shall be of PVC to comply with BS5255
5. All ICs within building area driveway and parking to have heavy duty, double-seal airtight covers and walls to be 200mm.
6. Minimum slope in the drain pipes to be 1%
7. No chases for pipes will be allowed in the slabs
8. Sleeves will be allowed with written approval from S.E.
9. No cutting of concrete without express approval of the Architect or S.E
10. All testing of pipes must be coordinated with electrical and any conflicts must be resolved before works begin
11. Permanent vents denoted as P.V to be provided as shown on plan.

**ELECTRICAL**

All conduits must be laid before plastering

**PROJECT:**

PROPOSED AFFORDABLE HOUSING DEVELOPMENT IN

**CLIENT:**

Name: STATE DEPARTMENT FOR HOUSING AND URBAN DEVELOPMENT

Signature: \_\_\_\_\_ Date: \_\_\_\_\_

**DRAWING TITLE:**

BLOCK A\_FLOOR PLANS

SCALE: 1:100

**DRAWN BY:**

ML

**CHECKED BY:**

Name: \_\_\_\_\_

Signature: \_\_\_\_\_ Date: \_\_\_\_\_

**DATE:**

MINISTRY OF LANDS, PUBLIC WORKS, HOUSING AND URBAN DEVELOPMENT

STATE DEPARTMENT FOR HOUSING & URBAN DEVELOPMENT



FOR THE GOVERNMENT OF THE REPUBLIC OF KENYA

**BLOCK TYPOLOGY A**

**[G+9]**



PROPOSED TYPICAL SOCIAL+ AFFORDABLE UNITS BLOCK TYPE A\_TYPICAL 2ND AND 9TH FLOOR PLAN

UNIT BREAK DOWN_ UNIT BREAK DOWN					
1_ROOM	2_ROOM	3_ROOM	STUDIO	2_BEDROOM	3_BEDROOM
1	2	1	2	4	1



PROPOSED TYPICAL SOCIAL+ AFFORDABLE UNITS BLOCK TYPE A\_TYPICAL 3RD AND 7TH FLOOR PLAN

UNIT BREAK DOWN_ UNIT BREAK DOWN					
1_ROOM	2_ROOM	3_ROOM	STUDIO	2_BEDROOM	3_BEDROOM
1	2	1	2	4	1

**GENERAL NOTES**

1. This drawing to be read in conjunction with Engineers' drawings.
2. All dimensions are in mm unless otherwise specified.
3. Drawings are not to be scaled. Only figured dimensions should be used.
4. The contractor must check and verify all dimensions before commencement of work and if necessary confirm with the architect.

**CONSTRUCTION**

Approved anti-termite treatment & 1000 gauge polythene sheeting cover to be provided under all ground floor concrete slab on compacted hardcore to approval.  
DPC to be 3ply bituminous felt to be provided under all walls.

**STRUCTURAL**

1. All Black cotton soil to be removed from below all building and paved surfaces
2. All reinforced concrete work will be in accordance with structural drawings.
3. Foundation depths to be determined on site to S.E approval
4. All walls less than 200mm thick to be reinforced with hoop iron at every alternate course.
5. All adjacent R.C work and masonry walls to be tied with strap irons at every course

**MECHANICAL**

1. All Plumbing and Drainage Work to comply with specifications
2. S.V.P denotes soil vent pipe and to be provided at the head of the drainage
3. Where drainage is shown under driveways and slabs, to be encased in 150mm thick concrete surround.
4. All underground foul and waste drain pipes shall be of PVC to comply with BS5255
5. All ICs within building area driveway and parking to have heavy duty, double-seal airtight covers and walls to be 200mm.
6. Minimum slope in the drain pipes to be 1%.
7. No chases for pipes will be allowed in the slabs
8. Sleeves will be allowed with written approval from S.E.
9. No cutting of concrete without express approval of the Architect or S.E
10. All testing of pipes must be coordinated with electrical and any conflicts must be resolved before works begin
11. Permanent vents denoted as P.V to be provided as shown on plan.

**ELECTRICAL**

All conduits must be laid before plastering

**PROJECT:**

PROPOSED AFFORDABLE HOUSING DEVELOPMENT IN

**CLIENT:**

Name: STATE DEPARTMENT FOR HOUSING AND URBAN DEVELOPMENT

Signature: \_\_\_\_\_ Date: \_\_\_\_\_

**DRAWING TITLE:**

BLOCK A\_FLOOR PLANS

SCALE: 1:100

**DRAWN BY:**

ML

**CHECKED BY:**

Name: \_\_\_\_\_

Signature: \_\_\_\_\_ Date: \_\_\_\_\_

**DATE:**

MINISTRY OF LANDS, PUBLIC WORKS, HOUSING AND URBAN DEVELOPMENT

STATE DEPARTMENT FOR HOUSING & URBAN DEVELOPMENT



FOR THE GOVERNMENT OF THE REPUBLIC OF KENYA

**BLOCK TYPOLOGY A**

**[G+9]**



PROPOSED TYPICAL SOCIAL+ AFFORDABLE UNITS BLOCK TYPE A\_TYPICAL 4TH AND 8TH FLOOR PLAN

UNIT BREAK DOWN		UNIT BREAK DOWN			
1_ROOM	2_ROOM	3_ROOM	STUDIO	2_BEDROOM	3_BEDROOM
1	2	1	2	4	1

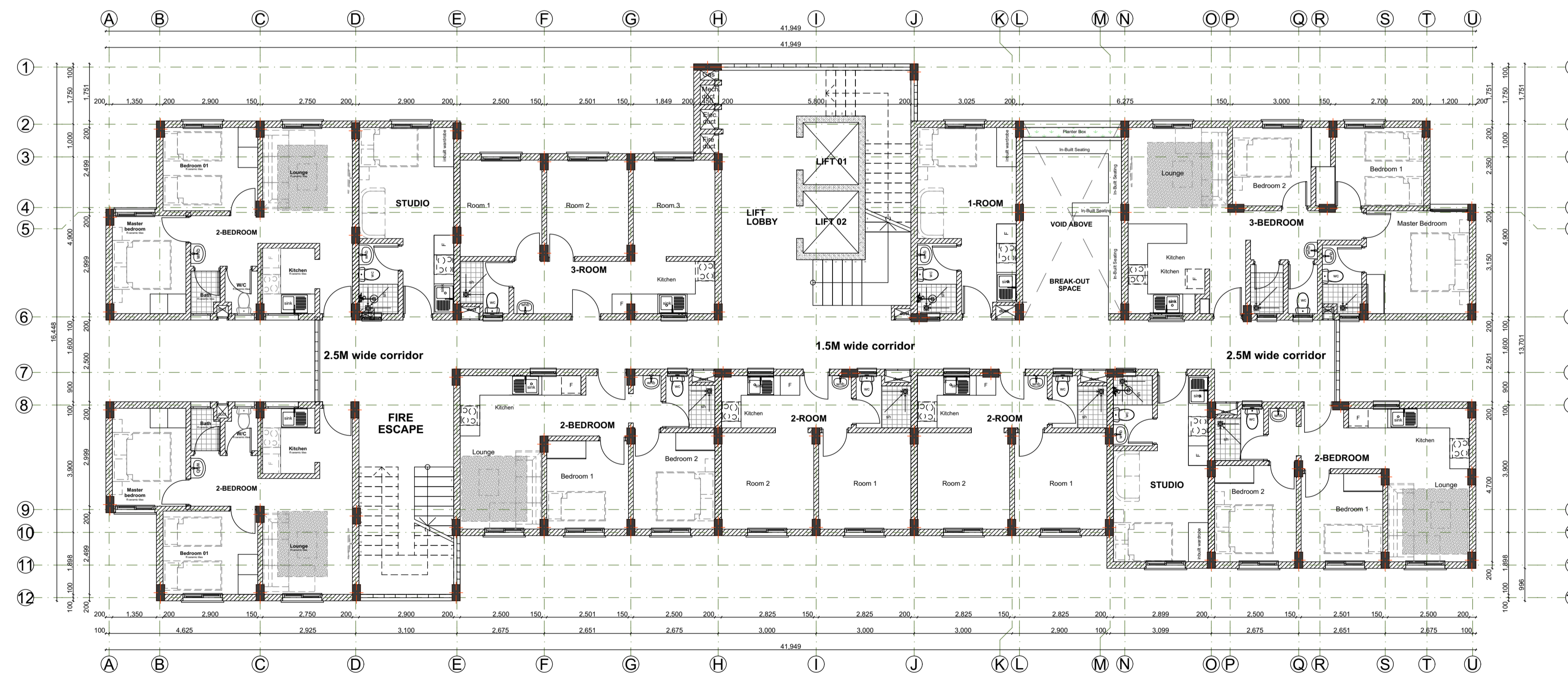

PROPOSED TYPICAL SOCIAL+ AFFORDABLE UNITS BLOCK TYPE A\_TYPICAL 5TH FLOOR PLAN

UNIT BREAK DOWN		UNIT BREAK DOWN			
1_ROOM	2_ROOM	3_ROOM	STUDIO	2_BEDROOM	3_BEDROOM
1	2	1	2	4	1

**GENERAL NOTES**

1. This drawing to be read in conjunction with Engineers' drawings.
2. All dimensions are in mm unless otherwise specified.
3. Drawings are not to be scaled. Only figured dimensions should be used.
4. The contractor must check and verify all dimensions before commencement of work and if necessary confirm with the architect.

**CONSTRUCTION**

Approved anti-termite treatment & 1000 gauge polythene sheeting cover to be provided under all ground floor concrete slab on compacted hardcore to approval.  
DPC to be 3ply bituminous felt to be provided under all walls.

**STRUCTURAL**

1. All Black cotton soil to be removed from below all building and paved surfaces
2. All reinforced concrete work will be in accordance with structural drawings.
3. Foundation depths to be determined on site to S.E approval
4. All walls less than 200mm thick to be reinforced with hoop iron at every alternate course.
5. All adjacent R.C work and masonry walls to be tied with strap irons at every course

**MECHANICAL**

1. All Plumbing and Drainage Work to comply with specifications
2. S.V.P denotes soil vent pipe and to be provided at the head of the drainage
3. Where drainage is shown under driveways and slabs, to be encased in 150mm thick concrete surround.
4. All underground foul and waste drain pipes shall be of PVC to comply with BS5255
5. All ICs within building area driveway and parking to have heavy duty, double-seal airtight covers and walls to be 200mm.
6. Minimum slope in the drain pipes to be 1%
7. No chases for pipes will be allowed in the slabs
8. Sleeves will be allowed with written approval from S.E.
9. No cutting of concrete without express approval of the Architect or S.E
10. All testing of pipes must be coordinated with electrical and any conflicts must be resolved before works begin
11. Permanent vents denoted as P.V to be provided as shown on plan.

**ELECTRICAL**

All conduits must be laid before plastering

**PROJECT:**

PROPOSED AFFORDABLE HOUSING DEVELOPMENT IN

**CLIENT:**

Name: STATE DEPARTMENT FOR HOUSING AND URBAN DEVELOPMENT

Signature: \_\_\_\_\_ Date: \_\_\_\_\_

**DRAWING TITLE:**

BLOCK A\_FLOOR PLANS

SCALE: 1:100

**DRAWN BY:**

ML

**CHECKED BY:**

Name: \_\_\_\_\_

Signature: \_\_\_\_\_ Date: \_\_\_\_\_

**DATE:**

MINISTRY OF LANDS, PUBLIC WORKS, HOUSING AND URBAN DEVELOPMENT  
STATE DEPARTMENT FOR HOUSING & URBAN DEVELOPMENT



FOR THE GOVERNMENT OF THE REPUBLIC OF KENYA

# BLOCK TYPOLOGY A

# [G+9]

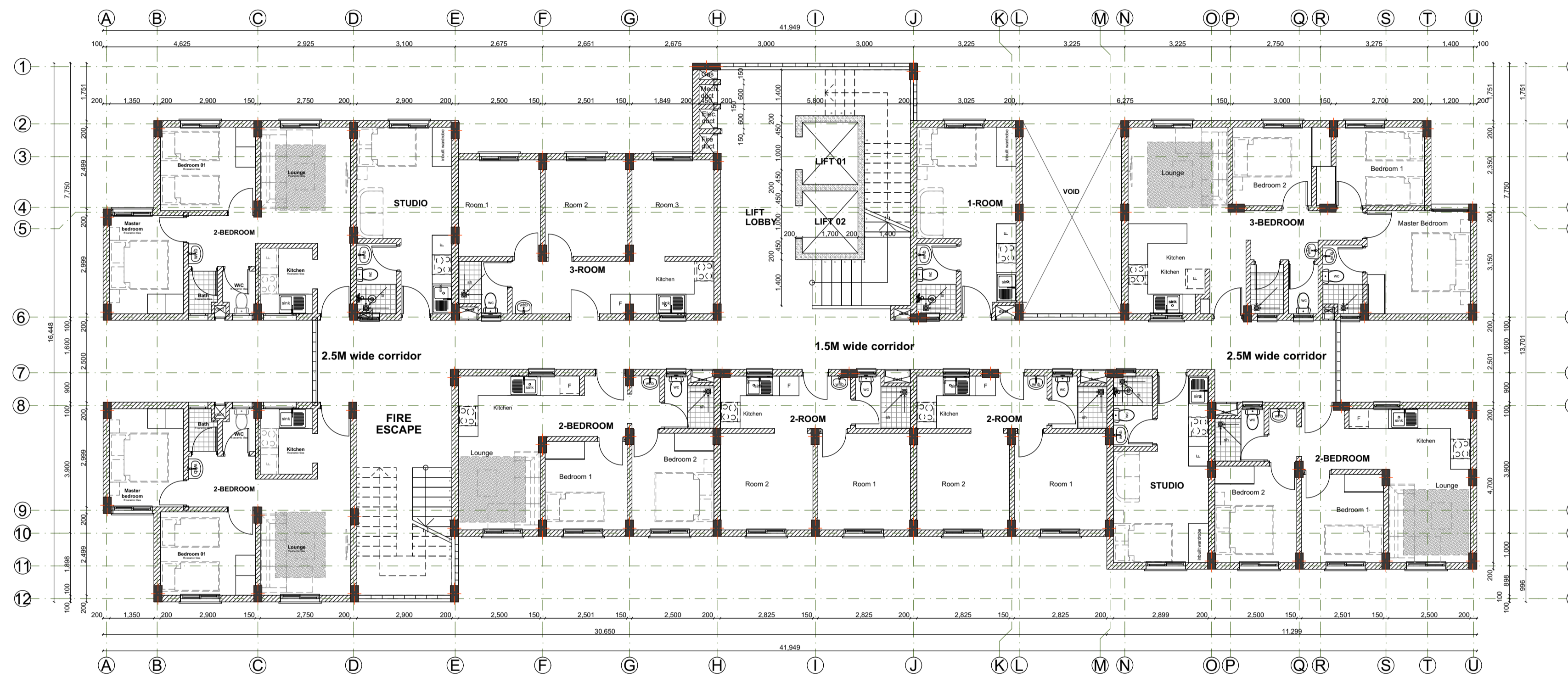

UNIT BREAK DOWN		UNIT BREAK DOWN	
1_ROOM	2_ROOM	3_ROOM	STUDIO
2_BEDROOM	3_BEDROOM		
1	2	1	2
		4	1

**GENERAL NOTES**

1. This drawing to be read in conjunction with Engineers' drawings.
2. All dimensions are in mm unless otherwise specified.
3. Drawings are not to be scaled. Only figured dimensions should be used.
4. The contractor must check and verify all dimensions before commencement of work and if necessary confirm with the architect.

**CONSTRUCTION**

Approved anti-termite treatment & 1000 gauge polythene sheeting cover to be provided under all ground floor concrete slab on compacted hardcore to approval. DPC to be 3ply bituminous felt to be provided under all walls.

**STRUCTURAL**

1. All Black cotton soil to be removed from below all building and paved surfaces
2. All reinforced concrete work will be in accordance with structural drawings.
3. Foundation depths to be determined on site to S.E approval
4. All walls less than 200mm thick to be reinforced with hoop iron at every alternate course.
5. All adjacent R.C work and masonry walls to be tied with strap irons at every course

**MECHANICAL**

1. All Plumbing and Drainage Work to comply with specifications
2. S.V.P denotes soil vent pipe and to be provided at the head of the drainage
3. Where drainage is shown under driveways and slabs, to be encased in 150mm thick concrete surround.
4. All underground foul and waste drain pipes shall be of PVC to comply with BS5255
5. All ICs within building area driveway and parking to have heavy duty, double-seal airtight covers and walls to be 200mm.
6. Minimum slope in the drain pipes to be 1%
7. No chases for pipes will be allowed in the slabs
8. Sleeves will be allowed with written approval from S.E.
9. No cutting of concrete without express approval of the Architect or S.E
10. All testing of pipes must be coordinated with electrical and any conflicts must be resolved before works begin
11. Permanent vents denoted as P.V to be provided as shown on plan.

**ELECTRICAL**

All conduits must be laid before plastering

**PROJECT:**  
PROPOSED AFFORDABLE HOUSING DEVELOPMENT IN

**CLIENT:**  
Name: STATE DEPARTMENT FOR HOUSING AND URBAN DEVELOPMENT  
Signature: \_\_\_\_\_ Date: \_\_\_\_\_

**DRAWING TITLE:**  
BLOCK A\_FLOOR PLANS

**SCALE:** 1:100

**DRAWN BY:**  
ML

**CHECKED BY:**  
Name: \_\_\_\_\_  
Signature: \_\_\_\_\_ Date: \_\_\_\_\_

**DATE:**

MINISTRY OF LANDS, PUBLIC WORKS,  
HOUSING AND URBAN DEVELOPMENT  
STATE DEPARTMENT FOR HOUSING & URBAN DEVELOPMENT



FOR THE GOVERNMENT OF THE  
REPUBLIC OF KENYA

# BLOCK TYPOLOGY A

# [G+9]

**GENERAL NOTES**

1. This drawing to be read in conjunction with Engineers' drawings.
2. All dimensions are in mm unless otherwise specified.
3. Drawings are not to be scaled. Only figured dimensions should be used.
4. The contractor must check and verify all dimensions before commencement of work and if necessary confirm with the architect.

**CONSTRUCTION**

- Approved anti-termite treatment & 1000 gauge polythene sheeting cover to be provided under all ground floor concrete slab on compacted hardcore to approval.  
DPC to be 3ply bituminous felt to be provided under all walls.

**STRUCTURAL**

1. All Black cotton soil to be removed from below all building and paved surfaces
2. All reinforced concrete work will be in accordance with structural drawings.
3. Foundation depths to be determined on site to S.E approval
4. All walls less than 200mm thick to be reinforced with hoop iron at every alternate course.
5. All adjacent R.C work and masonry walls to be tied with trap irons at every course

**MECHANICAL**

1. All Plumbing and Drainage Work to comply with specifications
2. S.V.P denotes soil vent pipe and to be provided at the head of the drainage
3. Where drainage is shown under driveways and slabs, to be encased in 150mm thick concrete surround.
4. All underground foul and waste drain pipes shall be of PVC to comply with BS5255
5. All ICs within building area driveway and parking to have heavy duty, double-seal airtight covers and walls to be 200mm.
6. Minimum slope in the drain pipes to be 1%
7. No chases for pipes will be allowed in the slabs
8. Sleeves will be allowed with written approval from S.E.
9. No cutting of concrete without express approval of the Architect or S.E
10. All testing of pipes must be coordinated with electrical and any conflicts must be resolved before works begin
11. Permanent vents denoted as P.V to be provided as shown on plan.

**ELECTRICAL**

All conduits must be laid before plastering

**PROJECT:**

PROPOSED AFFORDABLE HOUSING DEVELOPMENT IN

**CLIENT:**

Name: STATE DEPARTMENT FOR HOUSING AND URBAN DEVELOPMENT

Signature: \_\_\_\_\_ Date: \_\_\_\_\_

**DRAWING TITLE:**

BLOCK A\_FLOOR PLANS

SCALE: 1:100

**DRAWN BY:**

ML \_\_\_\_\_

**CHECKED BY:**

Name: \_\_\_\_\_

Signature: \_\_\_\_\_ Date: \_\_\_\_\_

**DATE:**

MINISTRY OF LANDS, PUBLIC WORKS, HOUSING AND URBAN DEVELOPMENT

STATE DEPARTMENT FOR HOUSING & URBAN DEVELOPMENT



FOR THE GOVERNMENT OF THE REPUBLIC OF KENYA

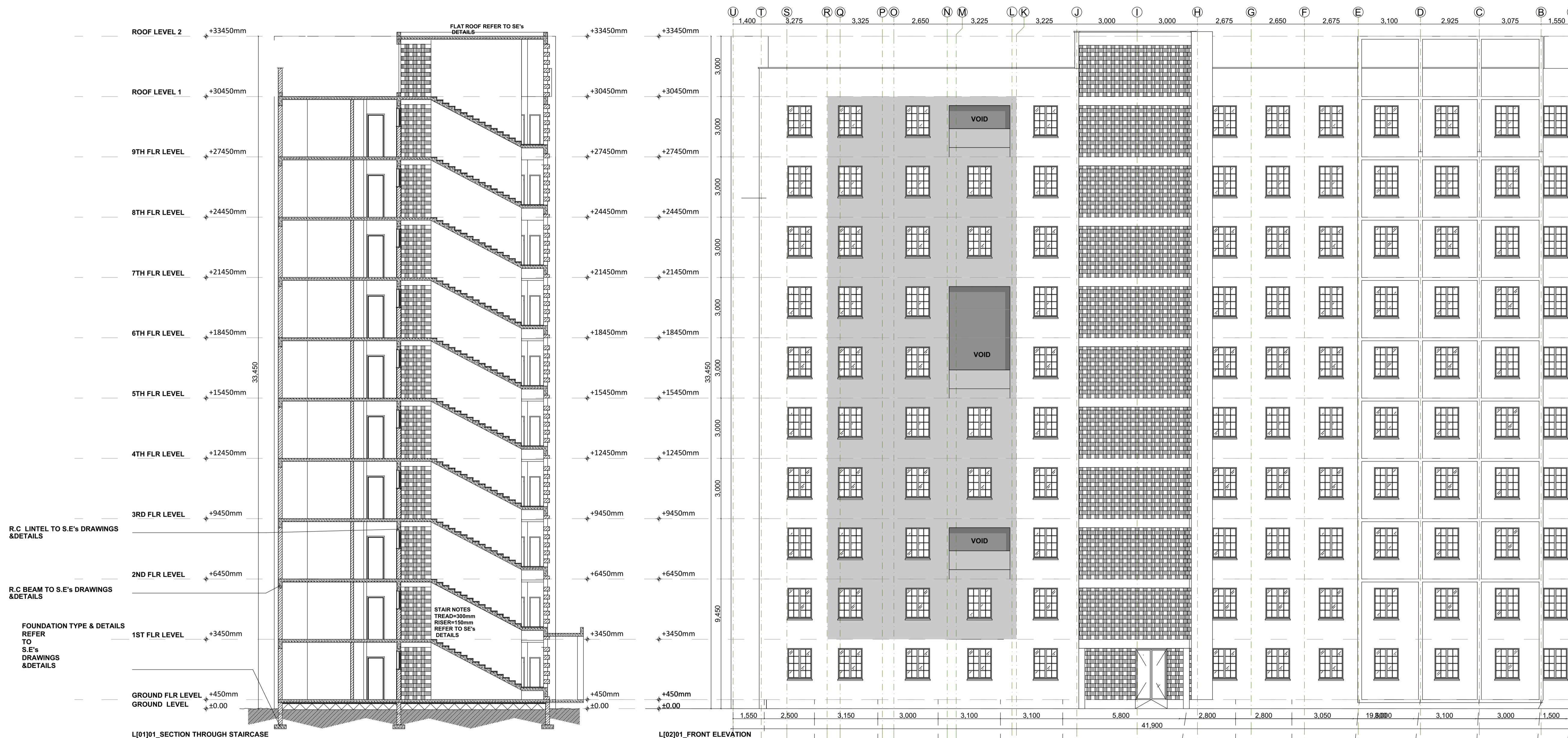

# BLOCK TYPOLOGY A

# [G+9]

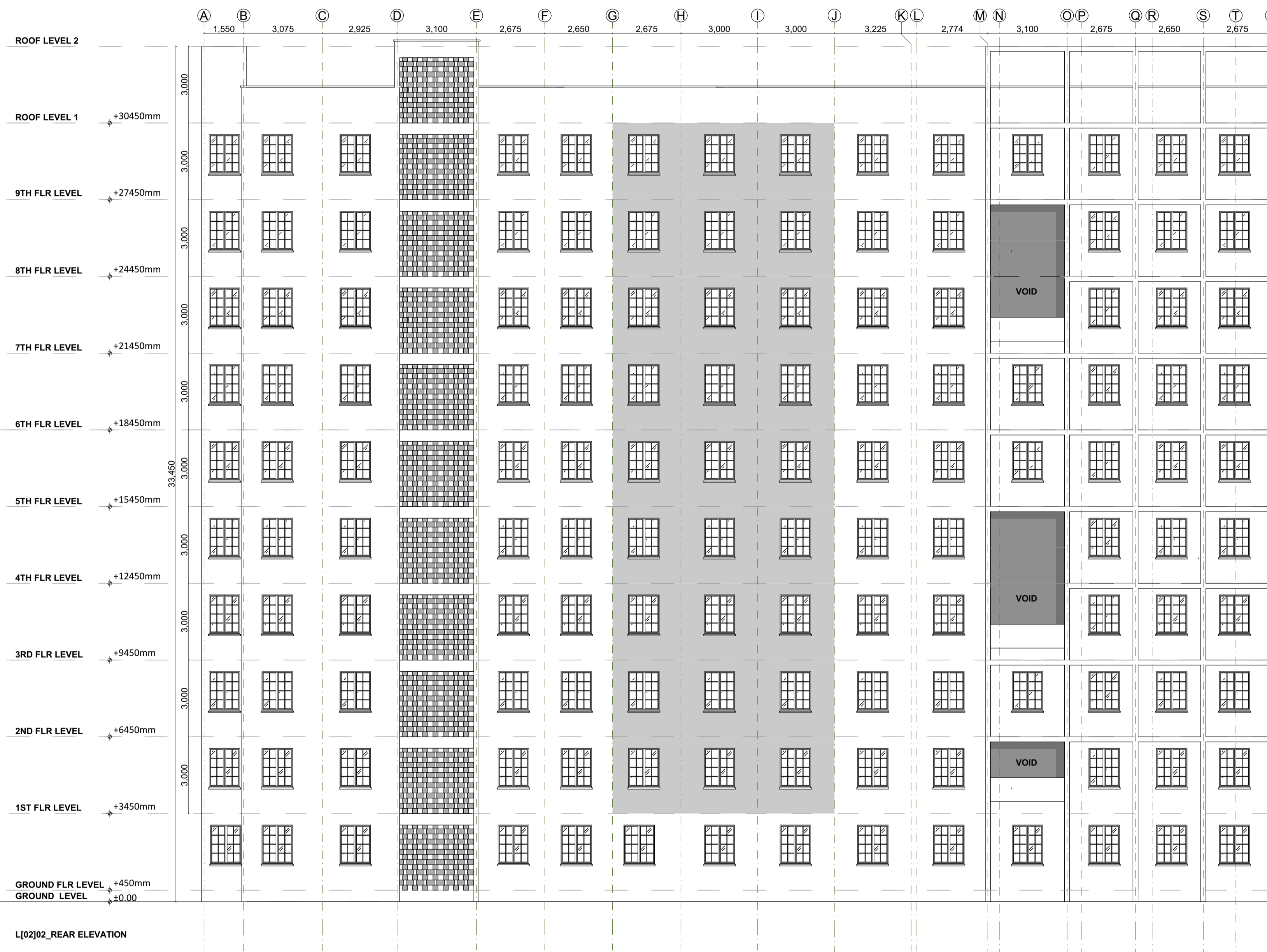

**GENERAL NOTES**

1. This drawing to be read in conjunction with Engineers' drawings.
2. All dimensions are in mm unless otherwise specified.
3. Drawings are not to be scaled. Only figured dimensions should be used.
4. The contractor must check and verify all dimensions before commencement of work and if necessary confirm with the architect.

**CONSTRUCTION**

Approved anti-termite treatment & 1000 gauge polythene sheeting cover to be provided under all ground floor concrete slab on compacted hardcore to approval.  
DPC to be 3ply bituminous felt to be provided under all walls.

**STRUCTURAL**

1. All Black cotton soil to be removed from below all building and paved surfaces
2. All reinforced concrete work will be in accordance with structural drawings.
3. Foundation depths to be determined on site to S.E approval
4. All walls less than 200mm thick to be reinforced with hoop iron at every alternate course.
5. All adjacent R.C work and masonry walls to be tied with strap irons at every course

**MECHANICAL**

1. All Plumbing and Drainage Work to comply with specifications
2. S.V.P denotes soil vent pipe and to be provided at the head of the drainage
3. Where drainage is shown under driveways and slabs, to be encased in 150mm thick concrete surround.
4. All underground foul and waste drain pipes shall be of PVC to comply with BS5255
5. All ICs within building area driveway and parking to have heavy duty, double-seal airtight covers and walls to be 200mm.
6. Minimum slope in the drain pipes to be 1%
7. No chases for pipes will be allowed in the slabs
8. Sleeves will be allowed with written approval from S.E.
9. No cutting of concrete without express approval of the Architect or S.E
10. All testing of pipes must be coordinated with electrical and any conflicts must be resolved before works begin
11. Permanent vents denoted as P.V to be provided as shown on plan.

**ELECTRICAL**

All conduits must be laid before plastering

**PROJECT:**

PROPOSED AFFORDABLE HOUSING DEVELOPMENT IN

**CLIENT:**

Name: STATE DEPARTMENT FOR HOUSING AND URBAN DEVELOPMENT

Signature: \_\_\_\_\_ Date: \_\_\_\_\_

**DRAWING TITLE:**

BLOCK A\_FLOOR PLANS

SCALE: 1:100

**DRAWN BY:**

ML

**CHECKED BY:**

Name: \_\_\_\_\_

Signature: \_\_\_\_\_ Date: \_\_\_\_\_

**DATE:**

MINISTRY OF LANDS, PUBLIC WORKS, HOUSING AND URBAN DEVELOPMENT

STATE DEPARTMENT FOR HOUSING & URBAN DEVELOPMENT



FOR THE GOVERNMENT OF THE REPUBLIC OF KENYA

**BLOCK TYPOLOGY A**

**[G+9]**



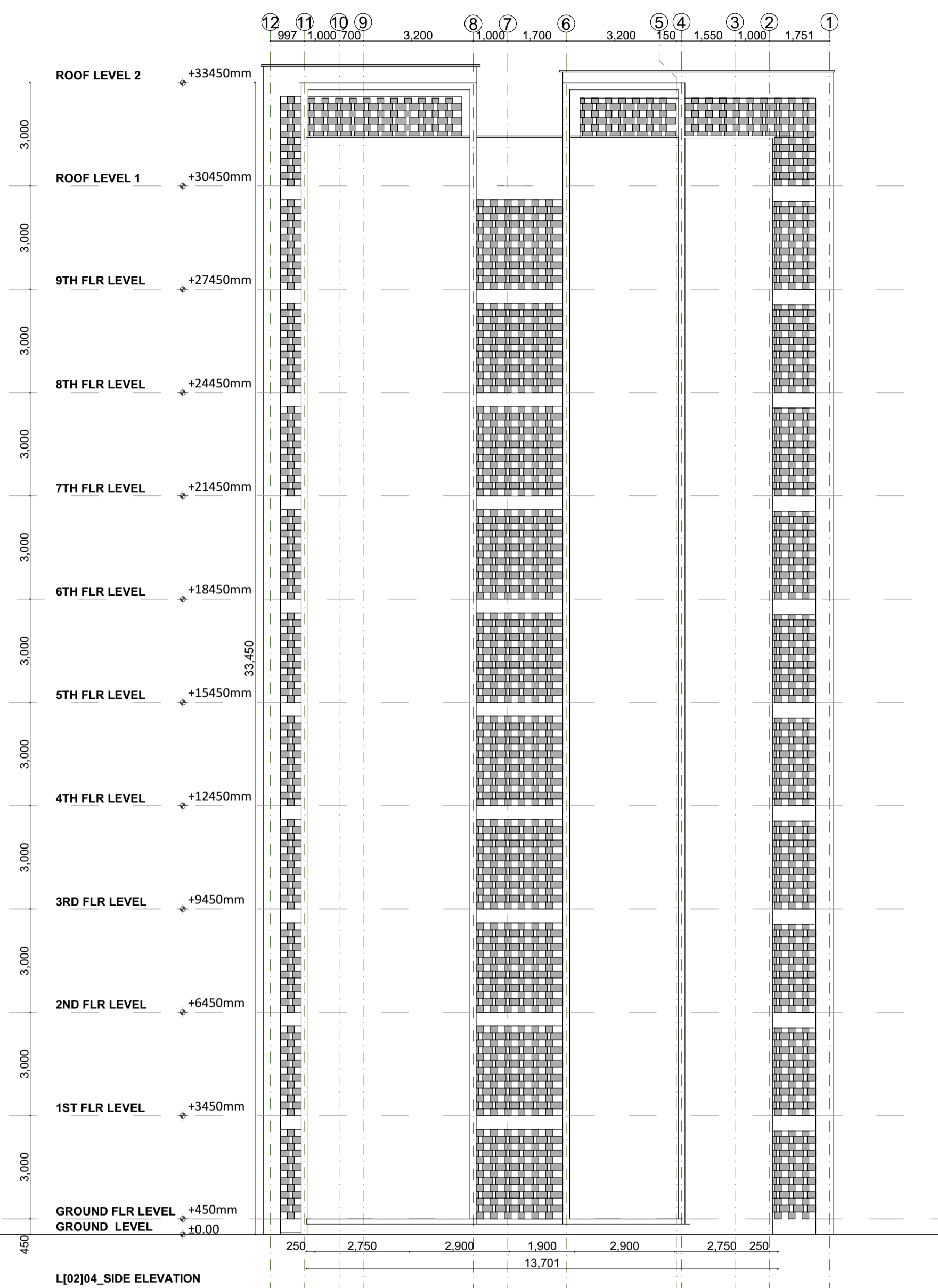
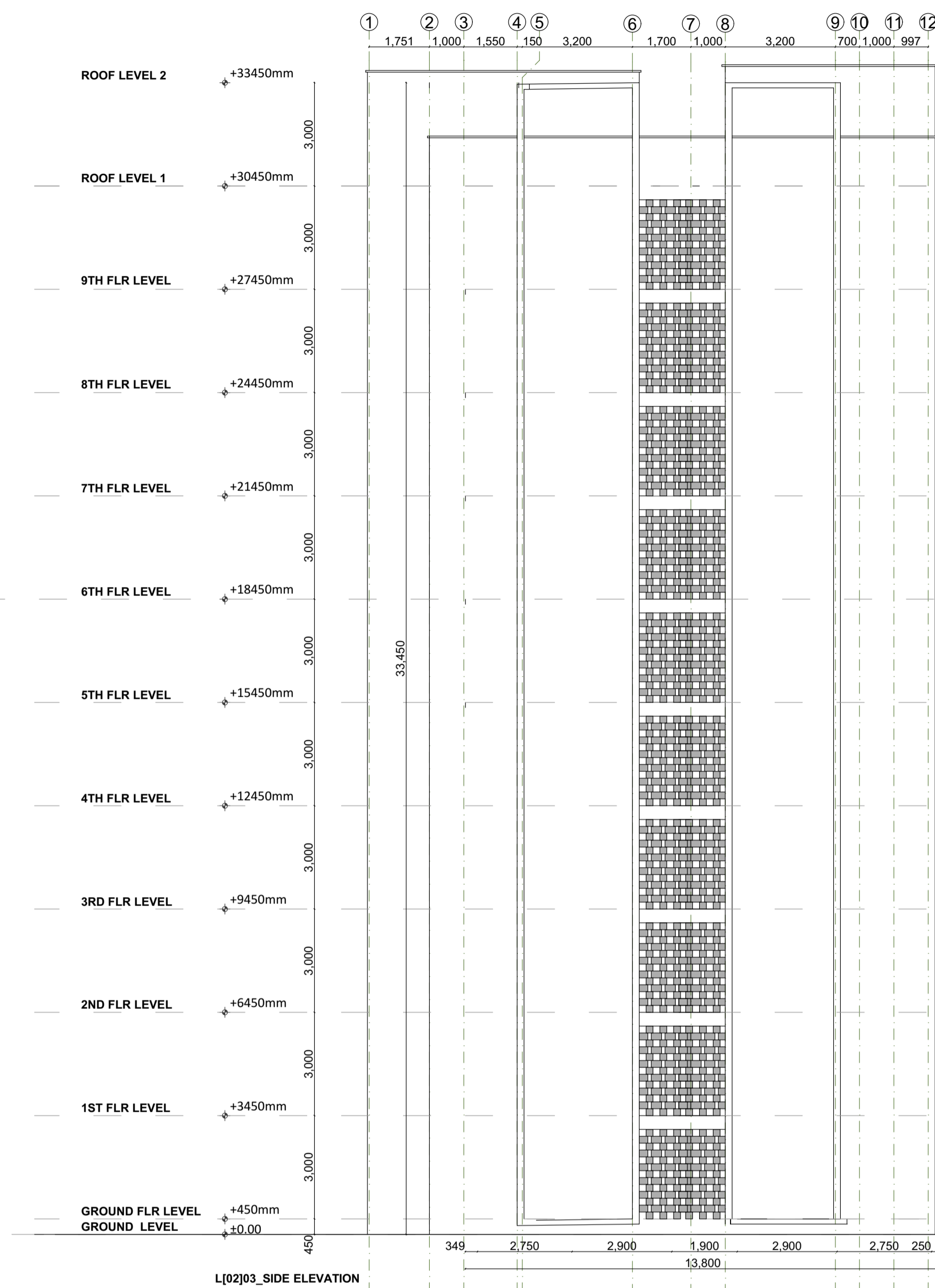

**GENERAL NOTES**

1. This drawing to be read in conjunction with Engineers' drawings.
2. All dimensions are in mm unless otherwise specified.
3. Drawings are not to be scaled. Only figured dimensions should be used.
4. The contractor must check and verify all dimensions before commencement of work and if necessary confirm with the architect.

**CONSTRUCTION**

Approved anti-termite treatment & 1000 gauge polythene sheeting cover to be provided under all ground floor concrete slab on compacted hardcore to approval.  
DPC to be 3ply bituminous felt to be provided under all walls.

**STRUCTURAL**

1. All Black cotton soil to be removed from below all building and paved surfaces
2. All reinforcing concrete work will be in accordance with structural drawings.
3. Foundation depths to be determined on site to S.E approval
4. All walls less than 200mm thick to be reinforced with hoop iron at every alternate course.
5. All adjacent R.C work and masonry walls to be tied with strap irons at every course

**MECHANICAL**

1. All Plumbing and Drainage Work to comply with specifications
2. S.V.P denotes soil vent pipe and to be provided at the head of the drainage
3. Where drainage is shown under driveways and slabs, to be encased in 150mm thick concrete surround.
4. All underground foul and waste drain pipes shall be of PVC to comply with BS5255
5. All ICs within building area driveway and parking to have heavy duty, double-seal airtight covers and walls to be 200mm.
6. Minimum slope in the drain pipes to be 1%
7. No chases for pipes will be allowed in the slabs
8. Sleeves will be allowed with written approval from S.E.
9. No cutting of concrete without express approval of the Architect or S.E
10. All testing of pipes must be coordinated with electrical and any conflicts must be resolved before works begin
11. Permanent vents denoted as P.V to be provided as shown on plan.

**ELECTRICAL**

All conduits must be laid before plastering

**PROJECT:**

PROPOSED AFFORDABLE HOUSING DEVELOPMENT IN

**CLIENT:**

Name: STATE DEPARTMENT FOR HOUSING AND URBAN DEVELOPMENT

Signature: \_\_\_\_\_ Date: \_\_\_\_\_

**DRAWING TITLE:**

BLOCK A \_FLOOR PLANS

SCALE: 1:100

**DRAWN BY:**

ML

**CHECKED BY:**

Name: \_\_\_\_\_

Signature: \_\_\_\_\_ Date: \_\_\_\_\_

**DATE:**

MINISTRY OF LANDS, PUBLIC WORKS, HOUSING AND URBAN DEVELOPMENT

STATE DEPARTMENT FOR HOUSING & URBAN DEVELOPMENT



FOR THE GOVERNMENT OF THE REPUBLIC OF KENYA

**BLOCK TYPOLOGY A**

**[G+9]**

# BLOCK TYPOLOGY B [G+9]

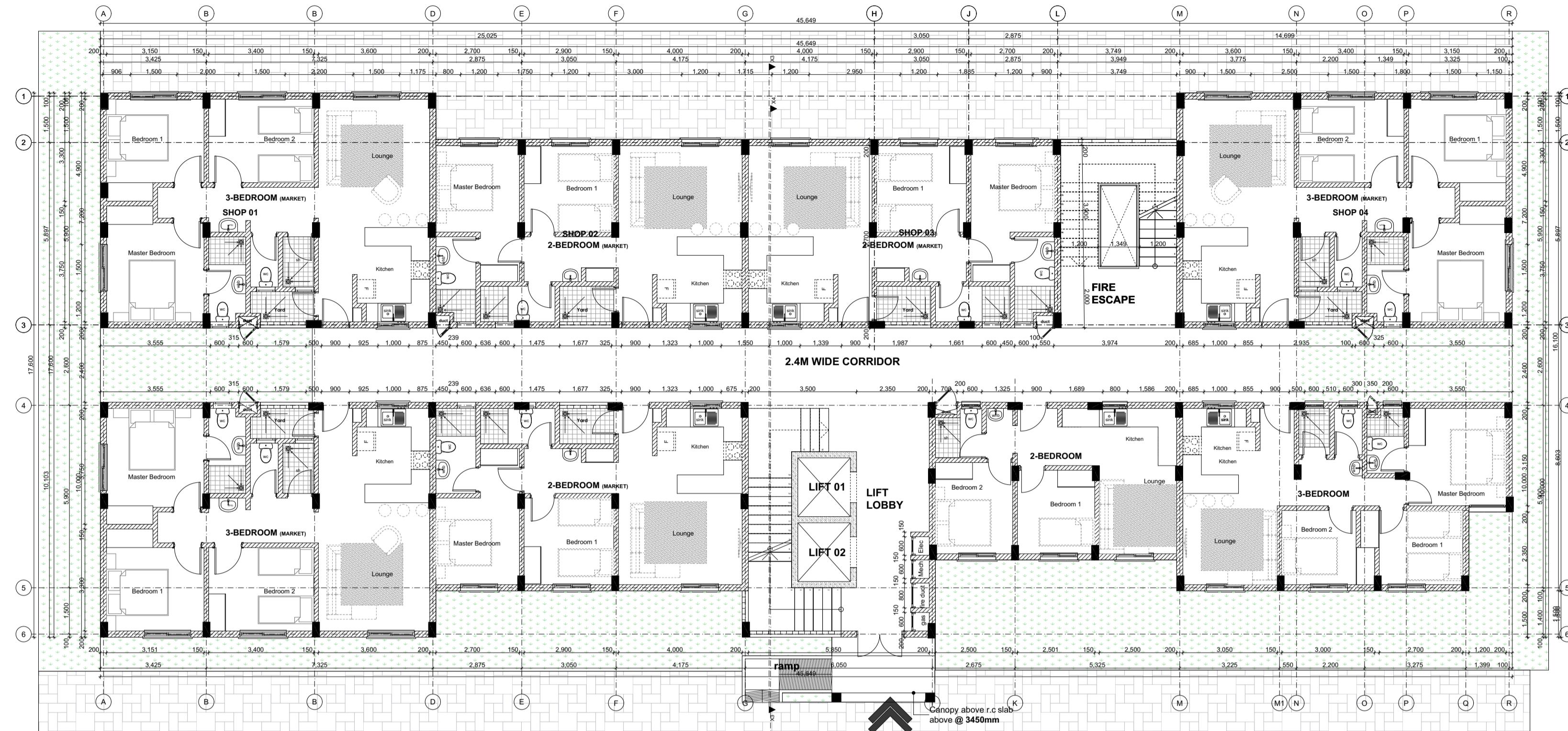

PROPOSED REVISED TYPICAL AFFORDABLE + MARKET UNITS BLOCK TYPE B\_GROUND FLOOR PLAN

UNIT BREAK DOWN		UNIT BREAK DOWN	
AFFORDABLE UNITS		MARKET UNITS	
2_BEDROOM	3_BEDROOM	2_BEDROOM	3_BEDROOM
1	1	3	3



PROPOSED TYPICAL AFFORDABLE + MARKET UNITS BLOCK TYPE B\_TYPICAL 1ST-9TH FLOOR LEVEL

UNIT BREAK DOWN		UNIT BREAK DOWN	
AFFORDABLE UNITS		MARKET UNITS	
2_BEDROOM	3_BEDROOM	2_BEDROOM	3_BEDROOM
1	1	3	3

## GENERAL NOTES

1. This drawing to be read in conjunction with Engineers' drawings.
2. All dimensions are in mm unless otherwise specified.
3. Drawings are not to be scaled. Only figured dimensions should be used.
4. The contractor must check and verify all dimensions before commencement of work and if necessary confirm with the architect.

## CONSTRUCTION

Approved anti-termite treatment & 1000 gauge polythene sheeting cover to be provided under all ground floor concrete slab on compacted hardcore to approval.  
DPC to be 3ply bituminous felt to be provided under all walls.

## STRUCTURAL

1. All Black cotton soil to be removed from below all building and paved surfaces
2. All reinforced concrete work will be in accordance with structural drawings.
3. Foundation depths to be determined on site to S.E approval
4. All walls less than 200mm thick to be reinforced with hoop iron at every alternate course.
5. All adjacent R.C work and masonry walls to be tied with strap irons at every course

## MECHANICAL

1. All Plumbing and Drainage Work to comply with specifications
2. S.V.P denotes soil vent pipe and to be provided at the head of the drainage
3. Where drainage is shown under driveways and slabs, to be encased in 150mm thick concrete surround.
4. All underground foul and waste drain pipes shall be of PVC to comply with BS5255
5. All ICs within building area driveway and parking to have heavy duty, double-seal airtight covers and walls to be 200mm.
6. Minimum slope in the drain pipes to be 1%
7. No chases for pipes will be allowed in the slabs
8. Sleeves will be allowed with written approval from S.E.
9. No cutting of concrete without express approval of the Architect or S.E
10. All testing of pipes must be coordinated with electrical and any conflicts must be resolved before works begin
11. Permanent vents denoted as P.V to be provided as shown on plan.

## ELECTRICAL

All conduits must be laid before plastering

## PROJECT:

PROPOSED AFFORDABLE HOUSING DEVELOPMENT IN

## CLIENT:

Name: STATE DEPARTMENT FOR HOUSING AND URBAN DEVELOPMENT

Signature: \_\_\_\_\_ Date: \_\_\_\_\_

## DRAWING TITLE:

## SCALE:

## DRAWN BY:

## CHECKED BY:

Name: \_\_\_\_\_

Signature: \_\_\_\_\_ Date: \_\_\_\_\_

## DATE:

MINISTRY OF LANDS, PUBLIC WORKS, HOUSING AND URBAN DEVELOPMENT

STATE DEPARTMENT FOR HOUSING & URBAN DEVELOPMENT



FOR THE GOVERNMENT OF THE REPUBLIC OF KENYA

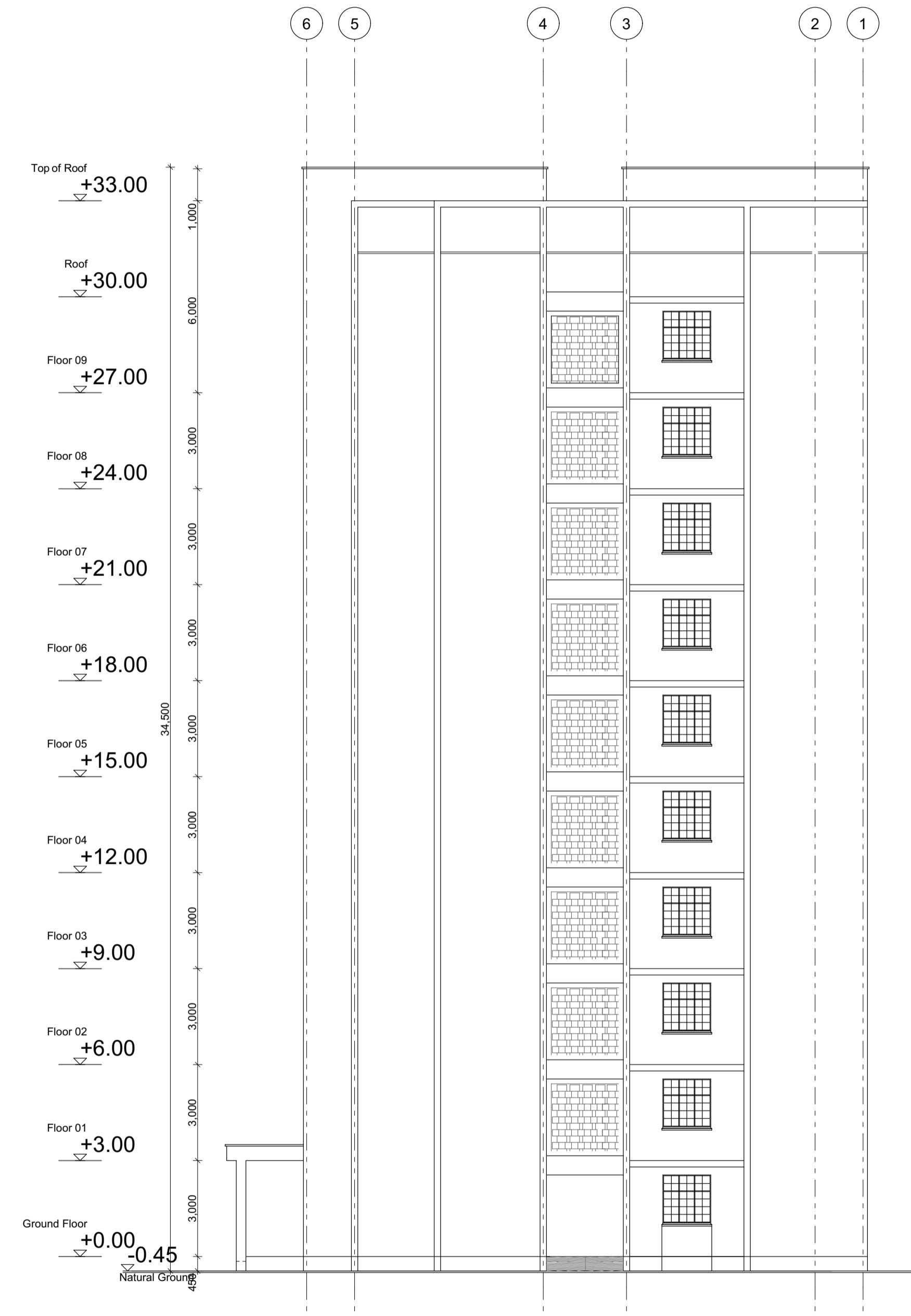
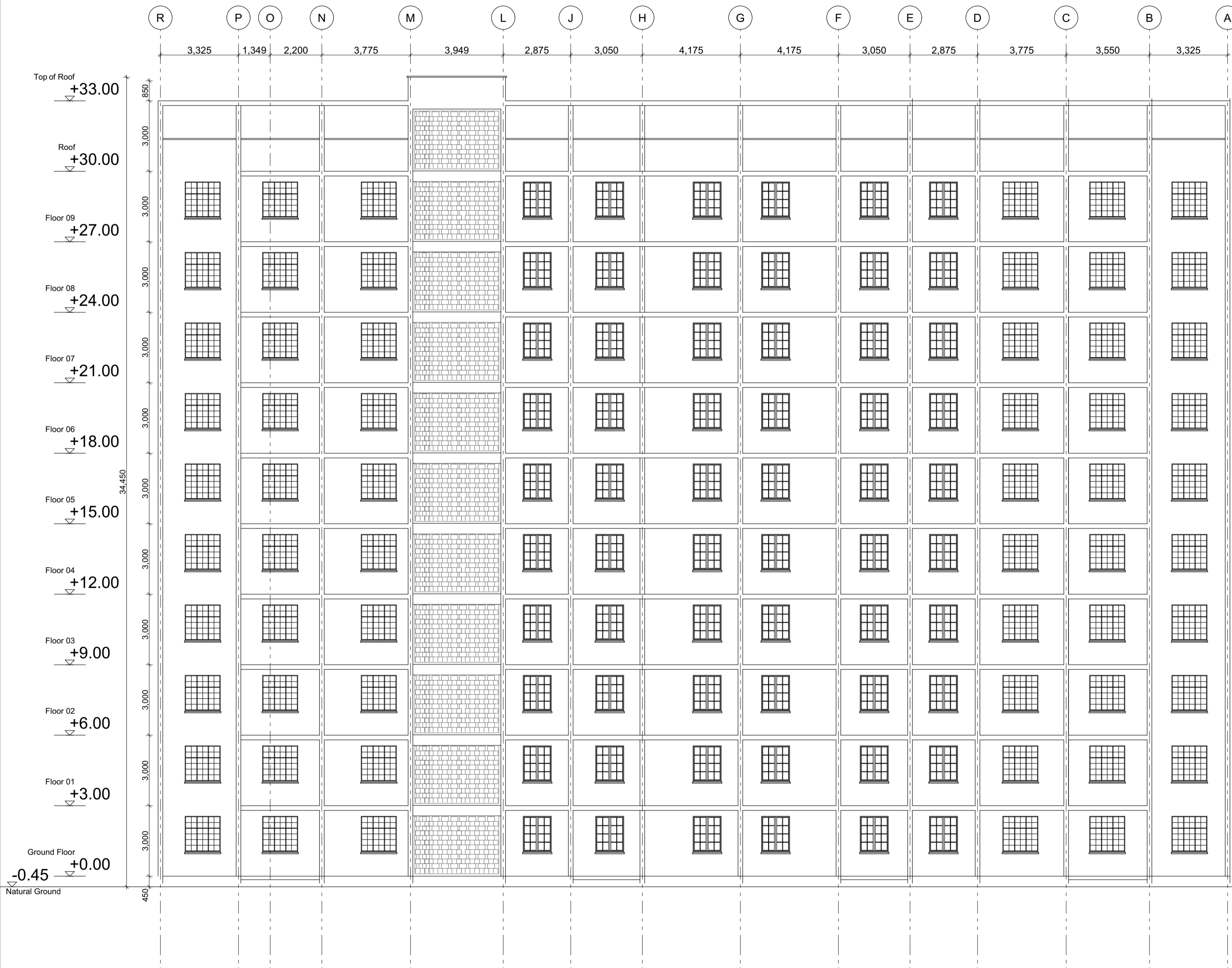

### GENERAL NOTES

1. This drawing to be read in conjunction with Engineers' drawings.
2. All dimensions are in mm unless otherwise specified.
3. Drawings are not to be scaled. Only figured dimensions should be used.
4. The contractor must check and verify all dimensions before commencement of work and if necessary confirm with the architect.

### CONSTRUCTION

Approved anti-termite treatment & 1000 gauge polythene sheeting cover to be provided under all ground floor concrete slab on compacted hardcore to approval.  
DPC to be 3ply bituminous felt to be provided under all walls.

### STRUCTURAL

1. All Black cotton soil to be removed from below all building and paved surfaces
2. All reinforced concrete work will be in accordance with structural drawings.
3. Foundation depths to be determined on site to S.E approval
4. All walls less than 200mm thick to be reinforced with hoop iron at every alternate course.
5. All adjacent R.C work and masonry walls to be tied with strap irons at every course

### MECHANICAL

1. All Plumbing and Drainage Work to comply with specifications
2. S.V.P denotes soil vent pipe and to be provided at the head of the drainage
3. Where drainage is shown under driveways and slabs, to be encased in 150mm thick concrete surround.
4. All underground foul and waste drain pipes shall be of PVC to comply with BS5255
5. All ICs within building area, driveway and parking to have heavy duty, double-seal airtight covers and walls to be 200mm.
6. Minimum slope in the drain pipes to be 1%
7. No chases for pipes will be allowed in the slabs
8. Sleeves will be allowed with written approval from S.E.
9. No cutting of concrete without express approval of the Architect or S.E
10. All testing of pipes must be coordinated with electrical and any conflicts must be resolved before works begin
11. Permanent vents denoted as P.V to be provided as shown on plan.

### ELECTRICAL

All conduits must be laid before plastering

### PROJECT:

PROPOSED AFFORDABLE HOUSING DEVELOPMENT IN

### CLIENT:

Name: STATE DEPARTMENT FOR HOUSING AND URBAN DEVELOPMENT

Signature: \_\_\_\_\_ Date: \_\_\_\_\_

### DRAWING TITLE:

### SCALE:

### DRAWN BY:

### CHECKED BY:

Name: \_\_\_\_\_

Signature: \_\_\_\_\_ Date: \_\_\_\_\_

### DATE:

MINISTRY OF LANDS, PUBLIC WORKS, HOUSING AND URBAN DEVELOPMENT

STATE DEPARTMENT FOR HOUSING & URBAN DEVELOPMENT



FOR THE GOVERNMENT OF THE REPUBLIC OF KENYA

**GENERAL NOTES**

1. This drawing to be read in conjunction with Engineers' drawings.
2. All dimensions are in mm unless otherwise specified.
3. Drawings are not to be scaled. Only figured dimensions should be used.
4. The contractor must check and verify all dimensions before commencement of work and if necessary confirm with the architect.

**CONSTRUCTION**

Approved anti-termite treatment & 1000 gauge polythene sheeting cover to be provided under all ground floor concrete slab on compacted hardcore to approval.  
DPC to be 3ply bituminous felt to be provided under all walls.

**STRUCTURAL**

1. All Black cotton soil to be removed from below all building and paved surfaces
2. All reinforced concrete work will be in accordance with structural drawings.
3. Foundation depths to be determined on site to S.E approval
4. All walls less than 200mm thick to be reinforced with hoop iron at every alternate course.
5. All adjacent R.C work and masonry walls to be tied with strap irons at every course

**MECHANICAL**

1. All Plumbing and Drainage Work to comply with specifications
2. S.V.P denotes soil vent pipe and to be provided at the head of the drainage
3. Where drainage is shown under driveways and slabs, to be encased in 150mm thick concrete surround.
4. All underground foul and waste drain pipes shall be of PVC to comply with BS5255
5. All ICs within building area, driveway and parking to have heavy duty, double-seal airtight covers and walls to be 200mm.
6. Minimum slope in the drain pipes to be 1%
7. No chases for pipes will be allowed in the slabs
8. Sleeves will be allowed with written approval from S.E.
9. No cutting of concrete without express approval of the Architect or S.E
10. All testing of pipes must be coordinated with electrical and any conflicts must be resolved before works begin
11. Permanent vents denoted as P.V to be provided as shown on plan.

**ELECTRICAL**

All conduits must be laid before plastering

**PROJECT:**

PROPOSED AFFORDABLE HOUSING DEVELOPMENT IN

**CLIENT:**

Name: STATE DEPARTMENT FOR HOUSING AND URBAN DEVELOPMENT

Signature: \_\_\_\_\_ Date: \_\_\_\_\_

**DRAWING TITLE:**

**SCALE:**

**DRAWN BY:**

**CHECKED BY:**

Name: \_\_\_\_\_

Signature: \_\_\_\_\_ Date: \_\_\_\_\_

**DATE:**

MINISTRY OF LANDS, PUBLIC WORKS, HOUSING AND URBAN DEVELOPMENT

STATE DEPARTMENT FOR HOUSING & URBAN DEVELOPMENT



FOR THE GOVERNMENT OF THE REPUBLIC OF KENYA

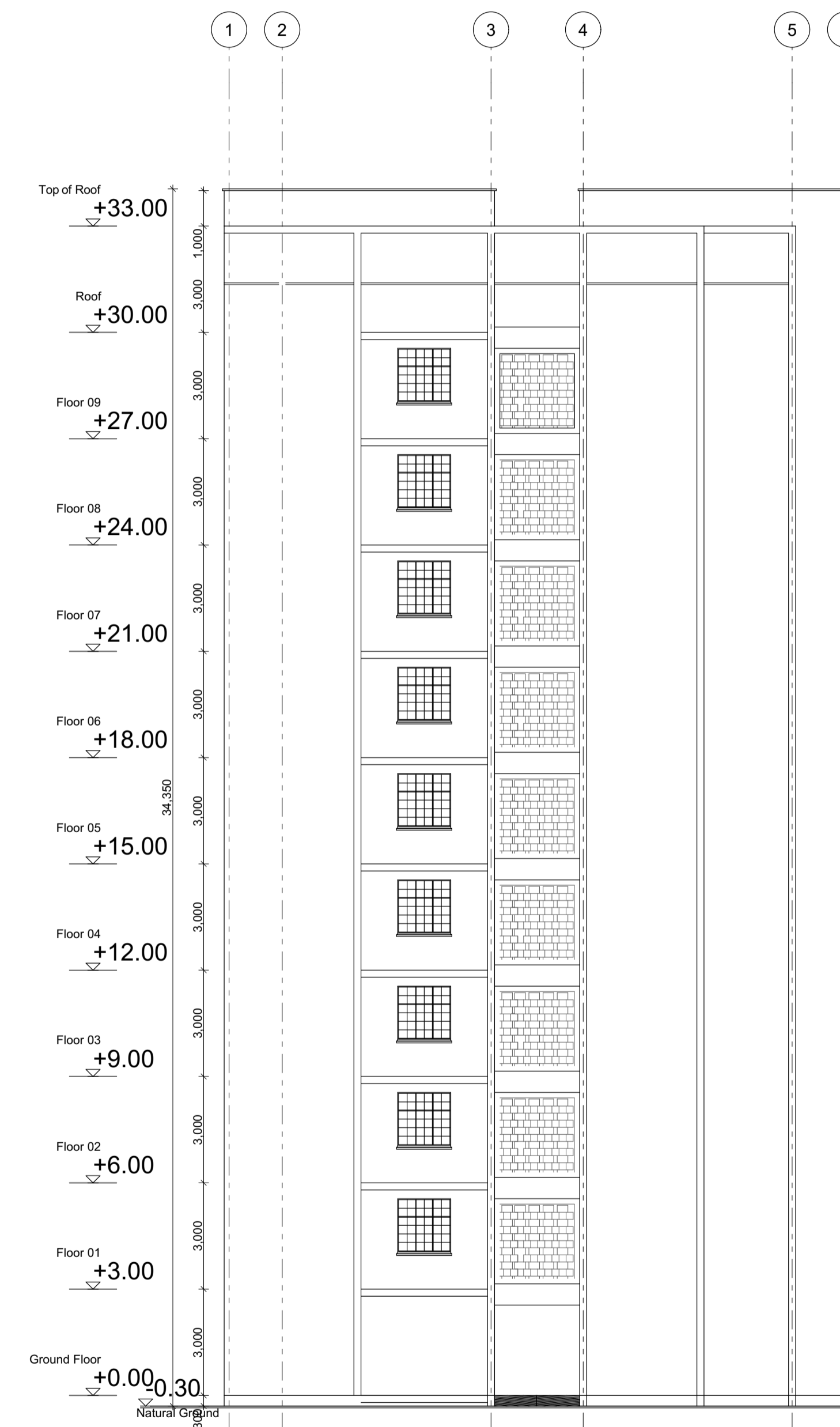
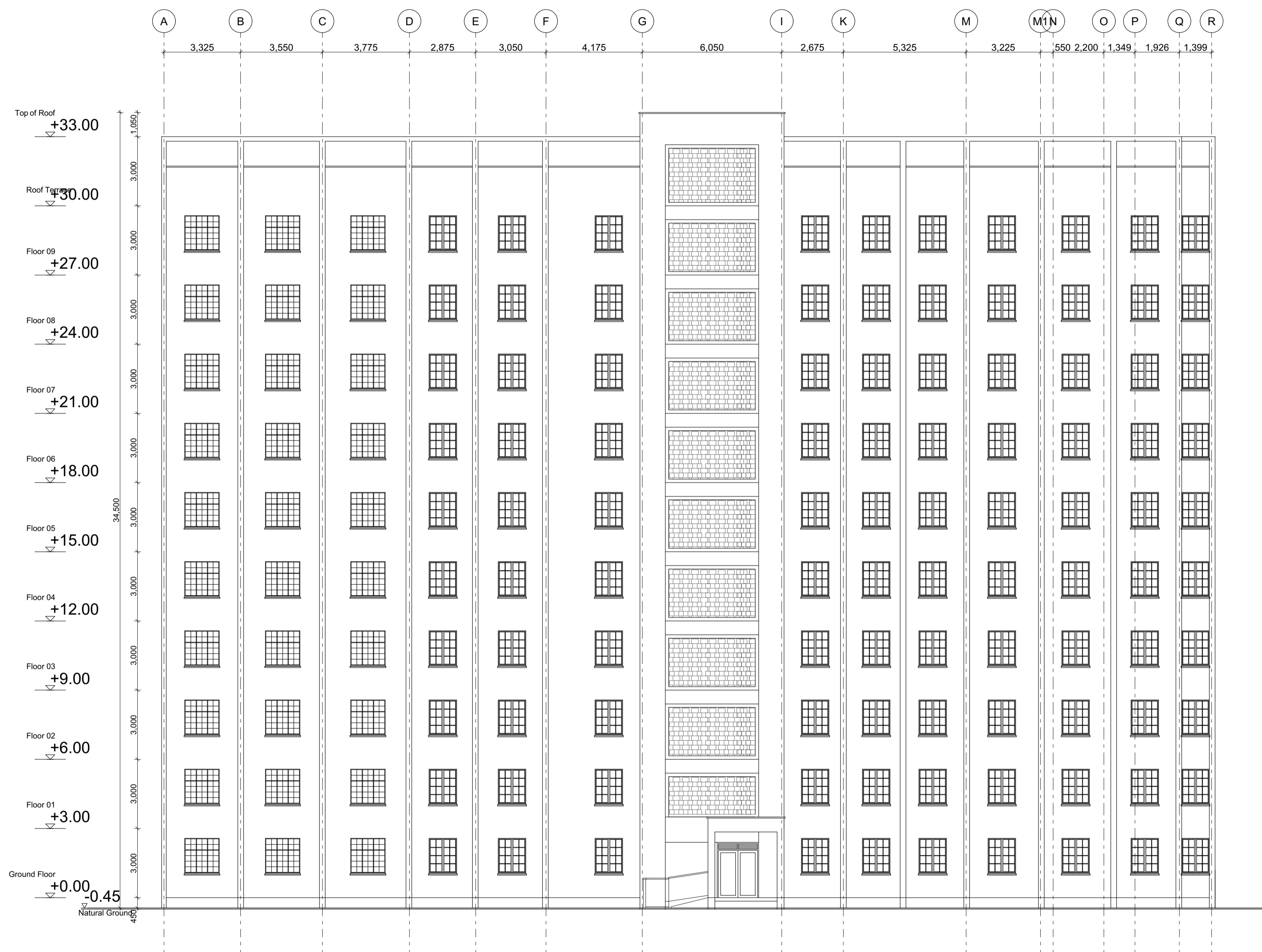

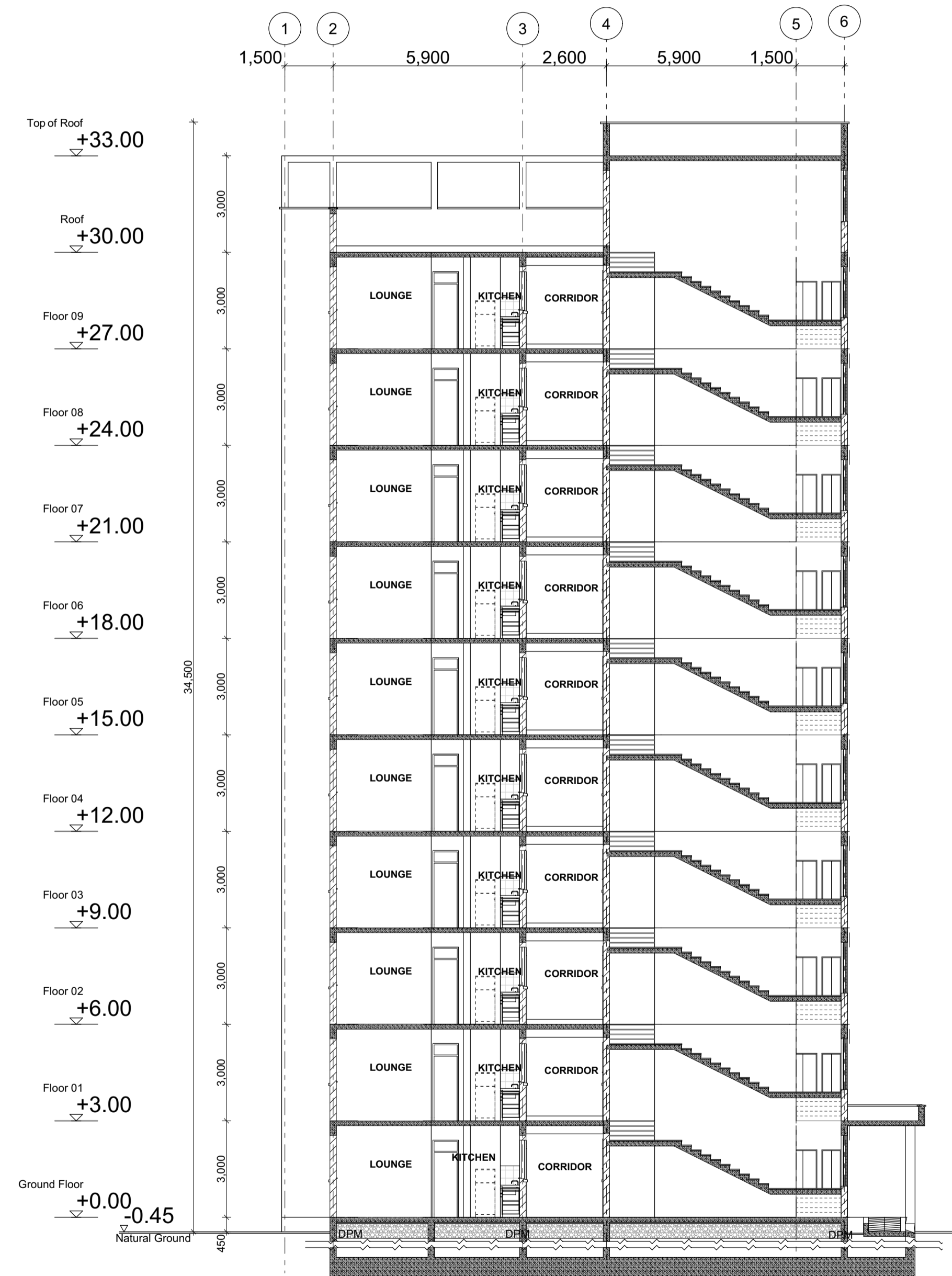

Foundation Type and Specifications to SE Details  
Refer to SE Drawings

### GENERAL NOTES

1. This drawing to be read in conjunction with Engineers' drawings.
2. All dimensions are in mm unless otherwise specified.
3. Drawings are not to be scaled. Only figured dimensions should be used.
4. The contractor must check and verify all dimensions before commencement of work and if necessary confirm with the architect.

### CONSTRUCTION

Approved anti-termite treatment & 1000 gauge polythene sheeting cover to be provided under all ground floor concrete slab on compacted hardcore to approval.  
DPC to be 3ply bituminous felt to be provided under all walls.

### STRUCTURAL

1. All Black cotton soil to be removed from below all building and paved surfaces
2. All reinforced concrete work will be in accordance with structural drawings.
3. Foundation depths to be determined on site to S.E approval
4. All walls less than 200mm thick to be reinforced with hoop iron at every alternate course.
5. All adjacent R.C work and masonry walls to be tied with strap irons at every course

### MECHANICAL

1. All Plumbing and Drainage Work to comply with specifications
2. S.V.P denotes soil vent pipe and to be provided at the head of the drainage
3. Where drainage is shown under driveways and slabs, to be encased in 150mm thick concrete surround.
4. All underground foul and waste drain pipes shall be of PVC to comply with BS5255
5. All ICs within building area, driveway and parking to have heavy duty, double-seal airtight covers and walls to be 200mm.
6. Minimum slope in the drain pipes to be 1%
7. No chases for pipes will be allowed in the slabs
8. Sleeves will be allowed with written approval from S.E.
9. No cutting of concrete without express approval of the Architect or S.E
10. All testing of pipes must be coordinated with electrical and any conflicts must be resolved before works begin
11. Permanent vents denoted as P.V to be provided as shown on plan.

### ELECTRICAL

All conduits must be laid before plastering

### PROJECT:

PROPOSED AFFORDABLE HOUSING DEVELOPMENT IN

### CLIENT:

Name: STATE DEPARTMENT FOR HOUSING AND URBAN DEVELOPMENT

Signature: \_\_\_\_\_ Date: \_\_\_\_\_

### DRAWING TITLE:

### SCALE:

### DRAWN BY:

### CHECKED BY:

Name: \_\_\_\_\_

Signature: \_\_\_\_\_ Date: \_\_\_\_\_

### DATE:

MINISTRY OF LANDS, PUBLIC WORKS, HOUSING AND URBAN DEVELOPMENT

STATE DEPARTMENT FOR HOUSING & URBAN DEVELOPMENT



FOR THE GOVERNMENT OF THE  
REPUBLIC OF KENYA

# **STRUCTURAL DRAWINGS**

---

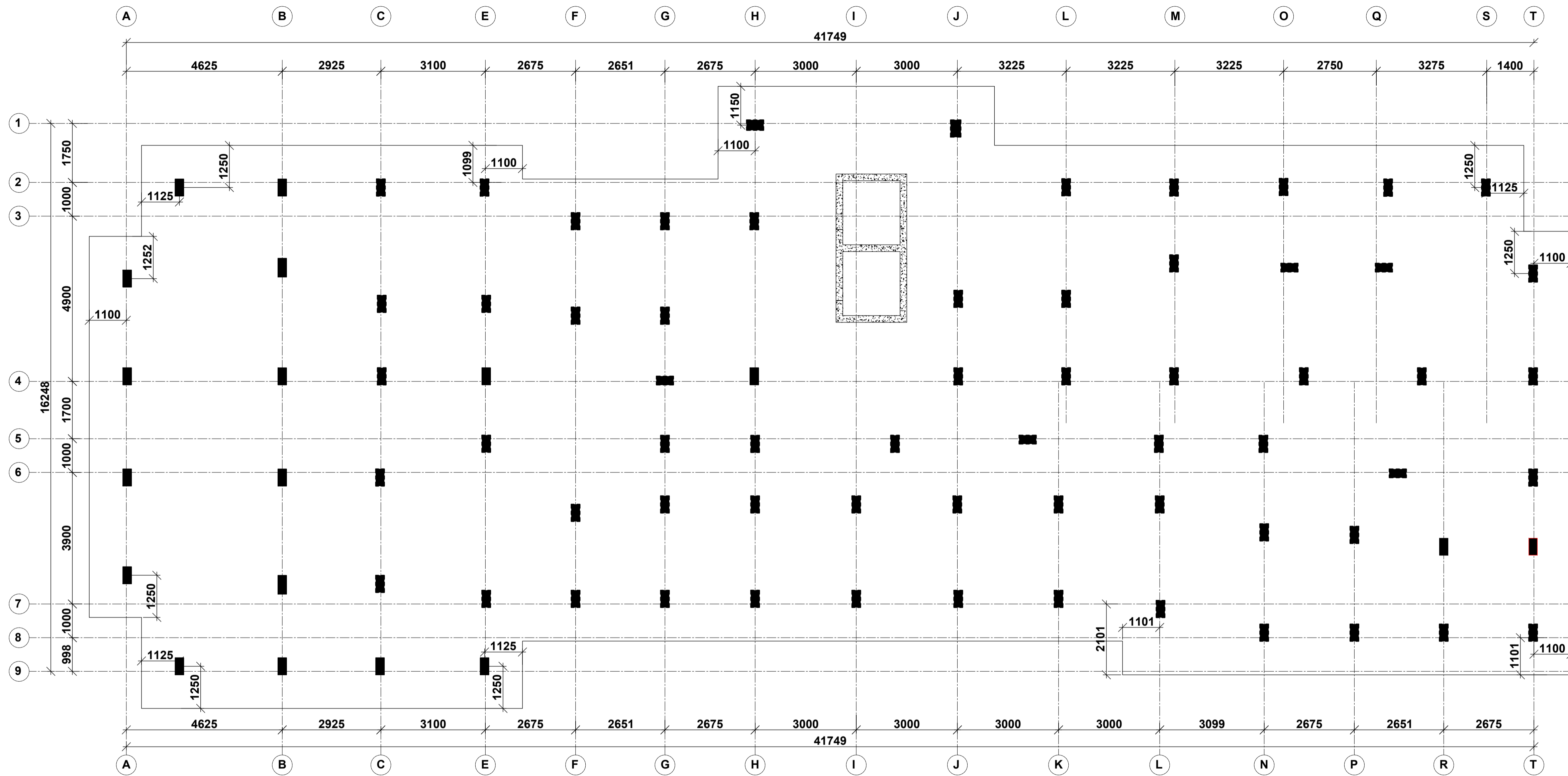

FOUNDATION LAYOUT  
750mm THICK RAFT  
SCALE 1:75

**NOTE:**

- Foundations to be excavated to a minimum depth of 3.5m
- Introduce a 300x200 ground beam over all the foundation wallings
- All masonry units to be machine cut blocks

**NOTES**  
 1. All dimensions are in millimetres unless otherwise stated.  
 2. All reinforcements must be checked and approved by project structural engineer prior to concreting.  
 3. All reinforced concrete to be Class 25 mix and blinding concrete to be Class 15 mix.  
 4. Only figured dimensions to be taken from this drawing.  
 5. Any discrepancy in dimensions to be reported to the project consultants i.e architect or engineer.

6. Symbols: T-TMT Rebars to BS 4461: T - Top face  
B - Bottom face  
 7. Cover to reinforcement; Slabs - 20mm, Beams - 25mm, Columns - 40mm, Foundations - 50mm  
 8. All structural steel be grade 43A.  
 9. All welds are 6mm thick.  
 10. All structural steel to be painted with anti-rust primer paint.

**Client**  
 MINISTRY OF LANDS, PUBLIC WORKS,  
 HOUSING AND URBAN DEVELOPMENT  
 STATE DEPARTMENT FOR HOUSING AND URBAN  
 DEVELOPMENT

**STRUCTURAL ENGINEER:**

Designed by: H.I.H      Checked by: R.M.O  
 Approved by: SECRETARY, HOUSING DEPARTMENT  
 Date: 17TH APRIL 2024      Scale: As shown  
 Drawing Number: AHP-G+9-BLKA 01

**Project**  
 PROPOSED AFFORDABLE HOUSING  
 PROGRAM-G+9 GENERIC BLOCK A.  
**Title**  
 FOUNDATION LAYOUT

Revisions		
No.	Description	Date

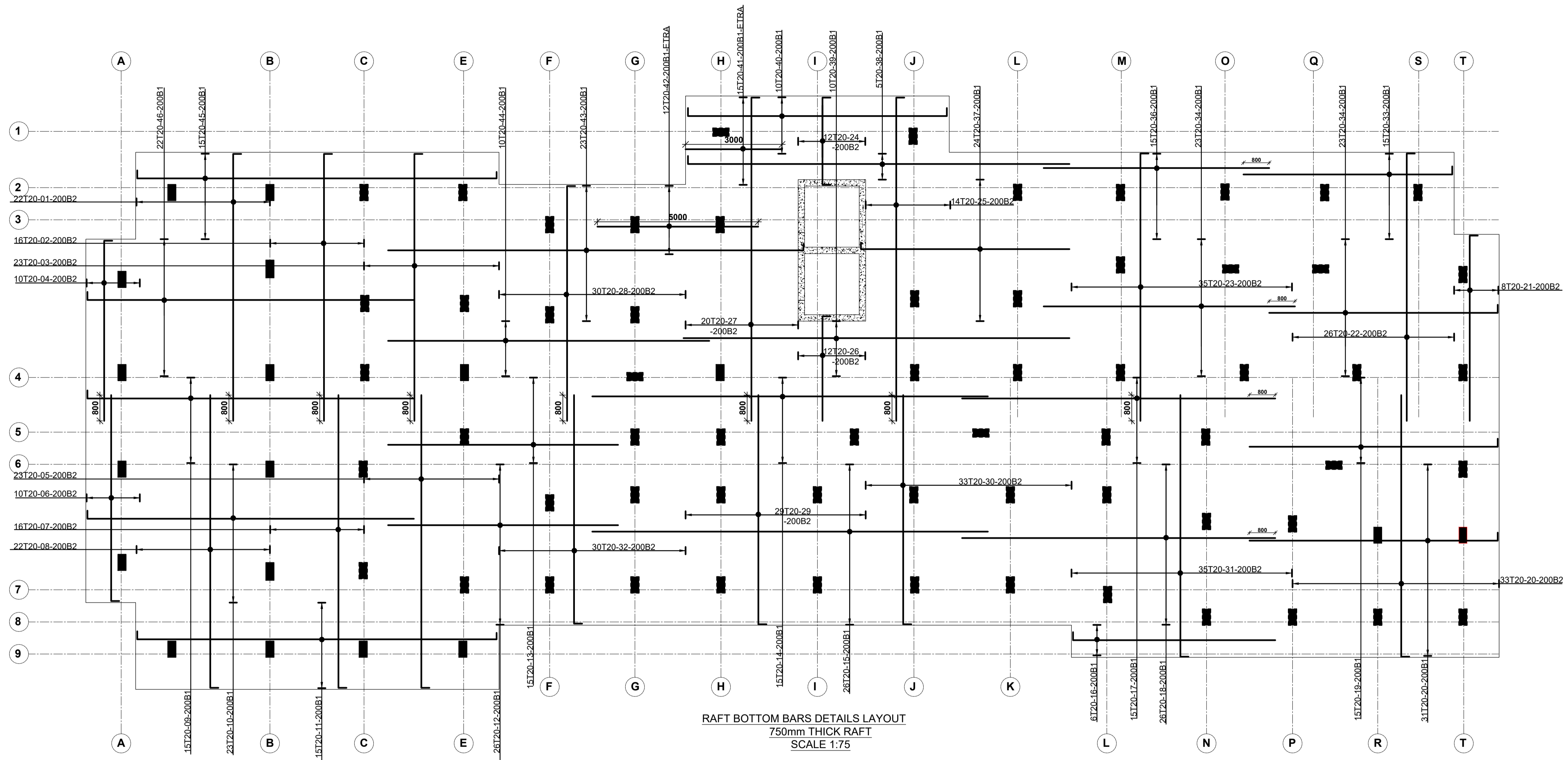

RAFT BOTTOM BARS DETAILS LAYOUT  
750mm THICK RAFT  
SCALE 1:75

**NOTE:**  
 1. Foundations to be excavated to a minimum depth of 3.5m  
 2. Introduce a 300x200 ground beam over all the foundation wallings  
 3. All masonry units to be machine cut blocks

**NOTES**  
 1. All dimensions are in millimetres unless otherwise stated.  
 2. All reinforcements must be checked and approved by project structural engineer prior to concreting.  
 3. All reinforced concrete to be Class 25 mix and blinding concrete to be Class 15 mix.  
 4. Only figured dimensions to be taken from this drawing.  
 5. Any discrepancy in dimensions to be reported to the project consultants i.e. architect or engineer.

6. Symbols: T-TMT Rebars to BS 4461: T - Top face  
 B - Bottom face  
 7. Cover to reinforcement; Slabs - 20mm,  
 Beams - 25mm, Columns - 40mm, Foundations - 50mm  
 8. All structural steel be grade 43A.  
 9. All welds are 6mm thick.  
 10. All structural steel to be painted with anti-rust primer paint.

**Client**  
 MINISTRY OF LANDS, PUBLIC WORKS,  
 HOUSING AND URBAN DEVELOPMENT  
 STATE DEPARTMENT FOR HOUSING AND URBAN  
 DEVELOPMENT

**STRUCTURAL ENGINEER:**

Designed by: H.I.H      Checked by: R.M.O  
 Approved by: SECRETARY, HOUSING DEPARTMENT  
 Date: 18TH APRIL 2024      Scale: As shown  
 Drawing Number: AHP-G+9-BLKA 02

**Project**  
 PROPOSED AFFORDABLE HOUSING  
 PROGRAM-G+9 GENERIC BLOCK A.  
**Title**  
 RAFT BOTTOM BAR DETAILS.

Revisions		
No.	Description	Date



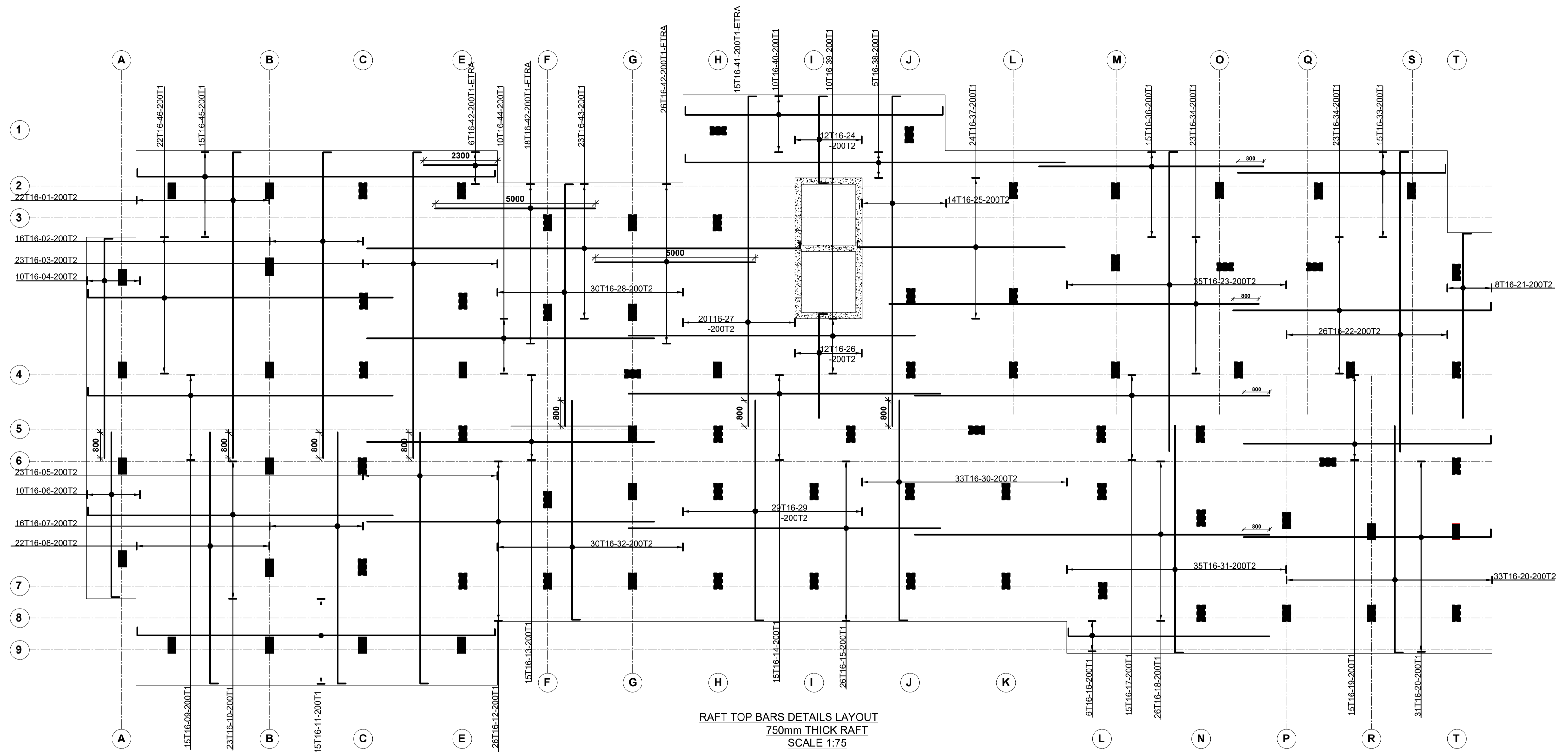

RAFT TOP BARS DETAILS LAYOUT  
750mm THICK RAFT  
SCALE 1:75

**NOTE:**

1. Foundations to be excavated to a minimum depth of 3.5m
2. Introduce a 300x200 ground beam over all the foundation wallings
3. All masonry units to be machine cut blocks

**NOTES**  
 1. All dimensions are in millimetres unless otherwise stated.  
 2. All reinforcements must be checked and approved by project structural engineer prior to concreting.  
 3. All reinforced concrete to be Class 25 mix and blinding concrete to be Class 15 mix.  
 4. Only figured dimensions to be taken from this drawing.  
 5. Any discrepancy in dimensions to be reported to the project consultants i.e. architect or engineer.

6. Symbols: T-TMT Rebars to BS 4461: T - Top face  
B - Bottom face  
 7. Cover to reinforcement; Slabs - 20mm, Beams - 25mm, Columns - 40mm, Foundations - 50mm  
 8. All structural steel be grade 43A.  
 9. All welds are 6mm thick.  
 10. All structural steel to be painted with anti-rust primer paint.

**Client**  
 MINISTRY OF LANDS, PUBLIC WORKS,  
 HOUSING AND URBAN DEVELOPMENT  
 STATE DEPARTMENT FOR HOUSING AND URBAN  
 DEVELOPMENT

**STRUCTURAL ENGINEER:**

Designed by: H.I.H      Checked by: R.M.O  
 Approved by: SECRETARY, HOUSING DEPARTMENT  
 Date: 18TH APRIL 2024      Scale: As shown  
 Drawing Number: AHP-G+9-BLKA 03

**Project**  
 PROPOSED AFFORDABLE HOUSING  
 PROGRAM-G+9 GENERIC BLOCK A.  
**Title**  
 RAFT TOP BAR DETAILS.

Revisions		
No.	Description	Date

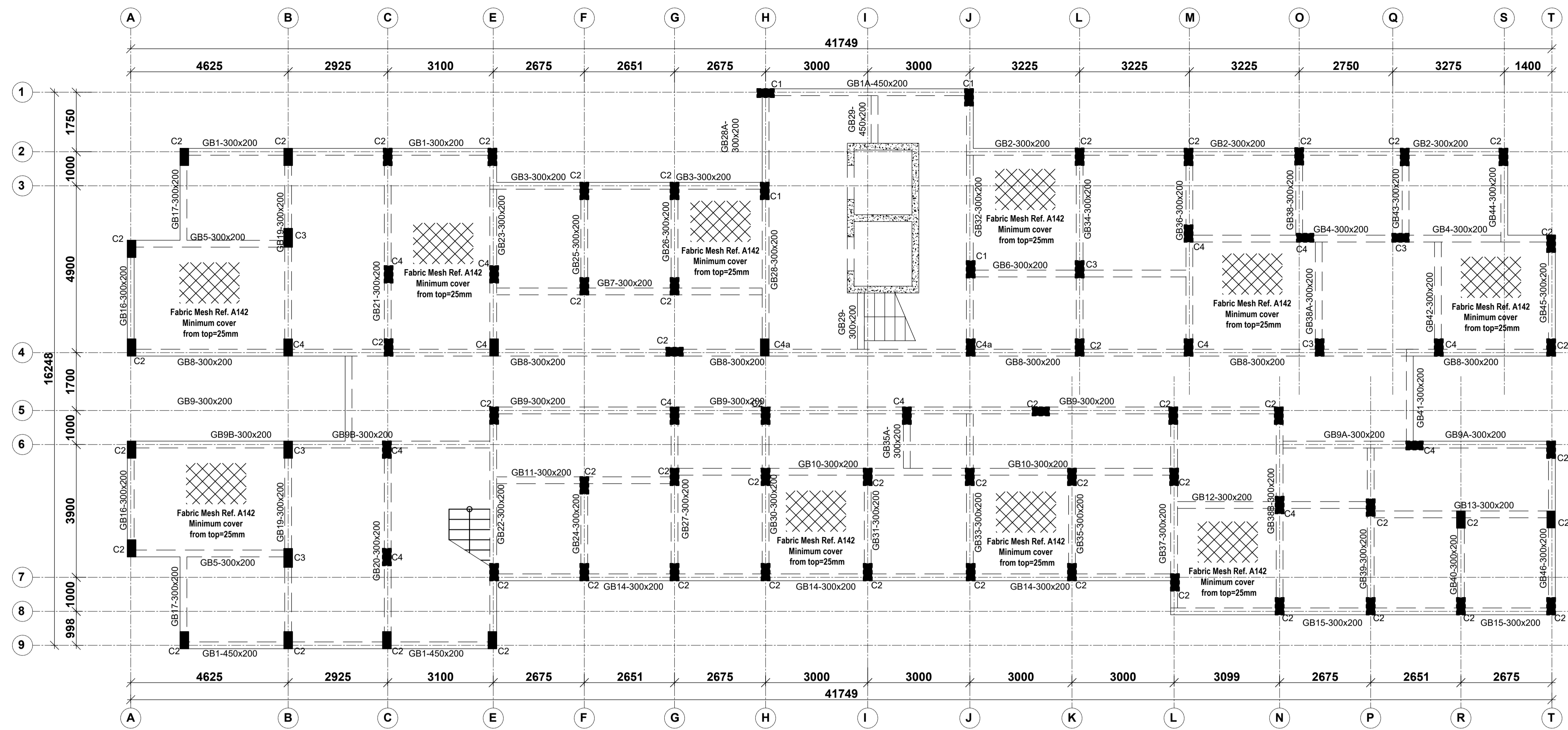

GROUND FLOOR LAYOUT  
100mm THICK SOLID SLAB ON GRADE  
SCALE 1:75

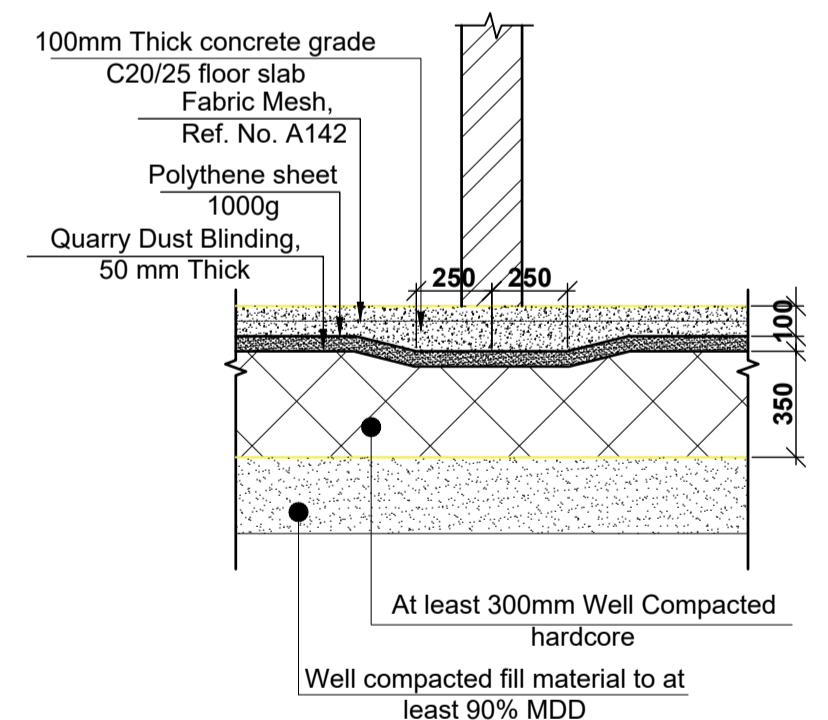
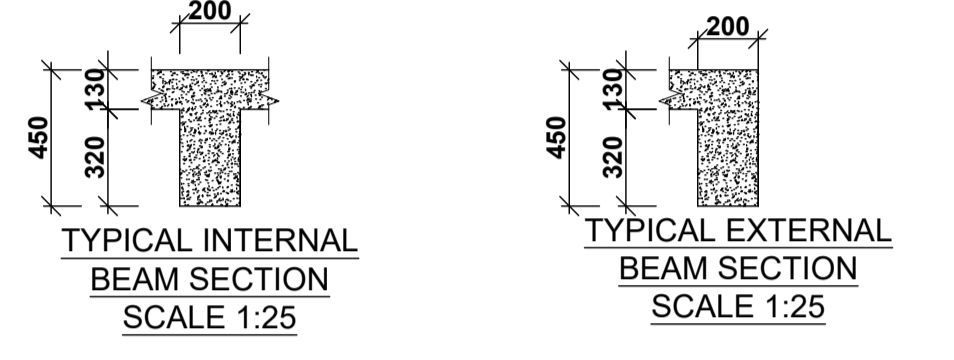

TYPICAL SLAB THICKENING THROUGH WALLS WITHOUT GROUND BEAMS  
SCALE 1:25

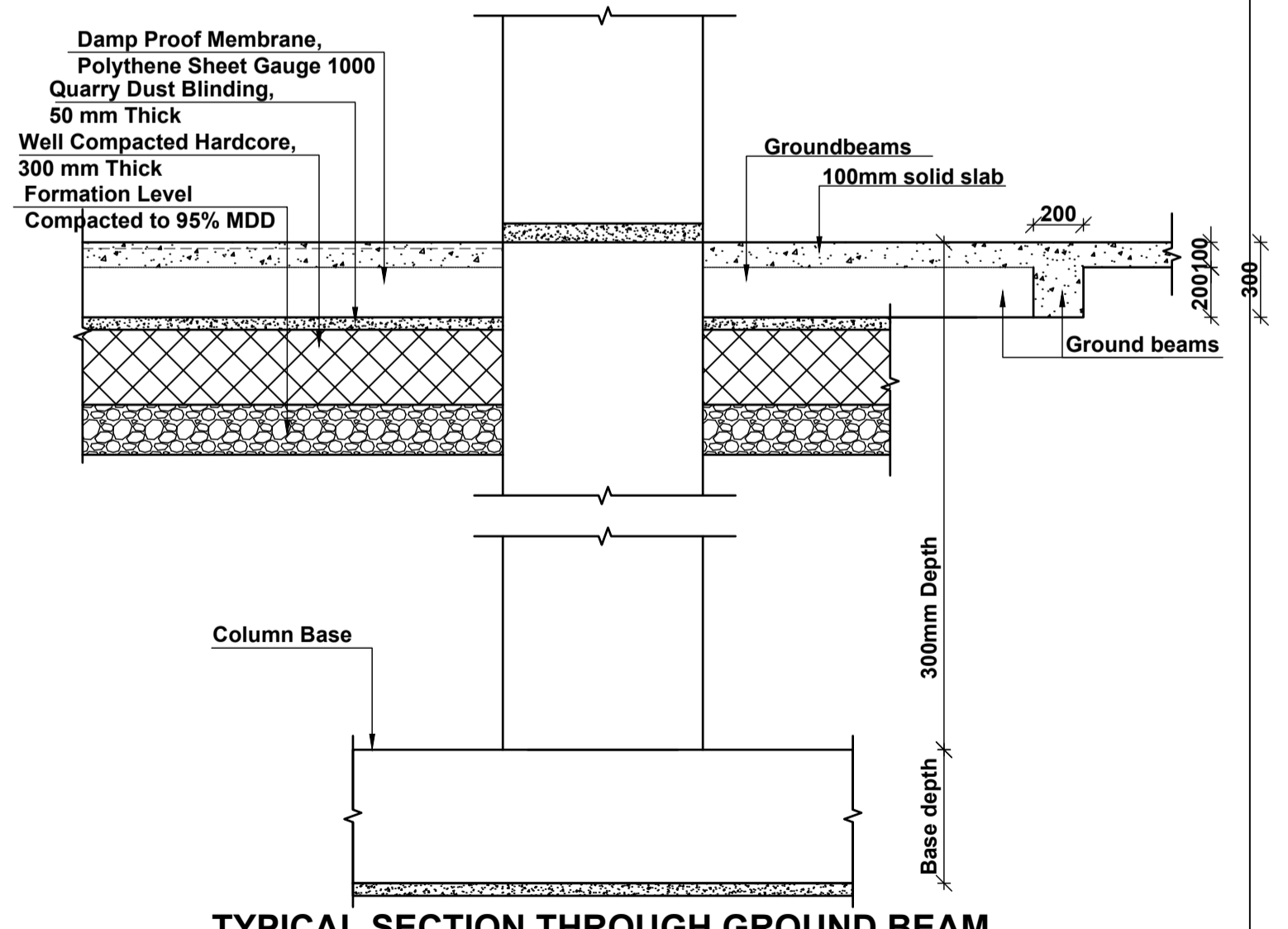

TYPICAL SECTION THROUGH GROUND BEAM  
SCALE 1:25

**NOTE:**  
1. Foundations to be excavated to a minimum depth of 3.5m  
2. Introduce a 300x200 ground beam over all the foundation wallings  
3. All masonry units to be machine cut blocks

**NOTES**  
1. All dimensions are in millimetres unless otherwise stated.  
2. All reinforcements must be checked and approved by project structural engineer prior to concreting.  
3. All reinforced concrete to be Class 25 mix and blinding concrete to be Class 15 mix.  
4. Only figured dimensions to be taken from this drawing.  
5. Any discrepancy in dimensions to be reported to the project consultants i.e. architect or engineer.

6. Symbols: T-TMT Rebars to BS 4461: T - Top face B - Bottom face  
7. Cover to reinforcement; Slabs - 20mm, Beams - 25mm, Columns - 40mm, Foundations - 50mm  
8. All structural steel be grade 43A.  
9. All welds are 6mm thick.  
10. All structural steel to be painted with anti-rust primer paint.

**Client**  
MINISTRY OF LANDS, PUBLIC WORKS, HOUSING AND URBAN DEVELOPMENT  
STATE DEPARTMENT FOR HOUSING AND URBAN DEVELOPMENT

**STRUCTURAL ENGINEER:**

Designed by: H.I.H Checked by: R.M.O  
Approved by: SECRETARY, HOUSING DEPARTMENT  
Date: 17TH APRIL 2024 Scale: As shown  
Drawing Number: AHP-G+9-BLKA 04

**Project**  
PROPOSED AFFORDABLE HOUSING PROGRAM-G+9 GENERIC BLOCK A.  
**Title**  
GROUND FLOOR LAYOUT

Revisions		
No.	Description	Date

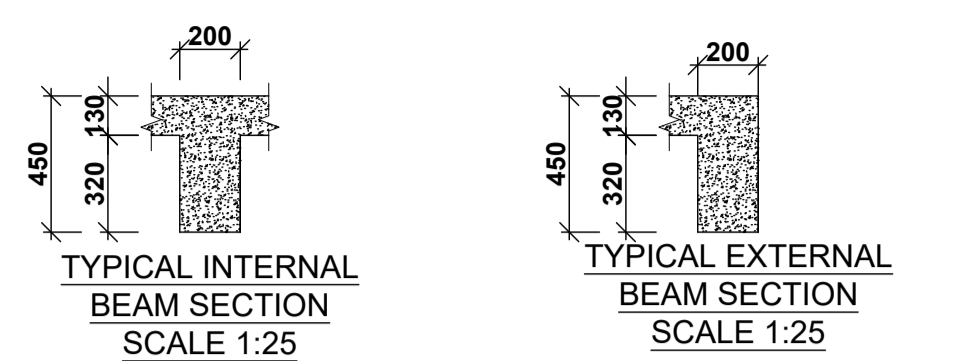
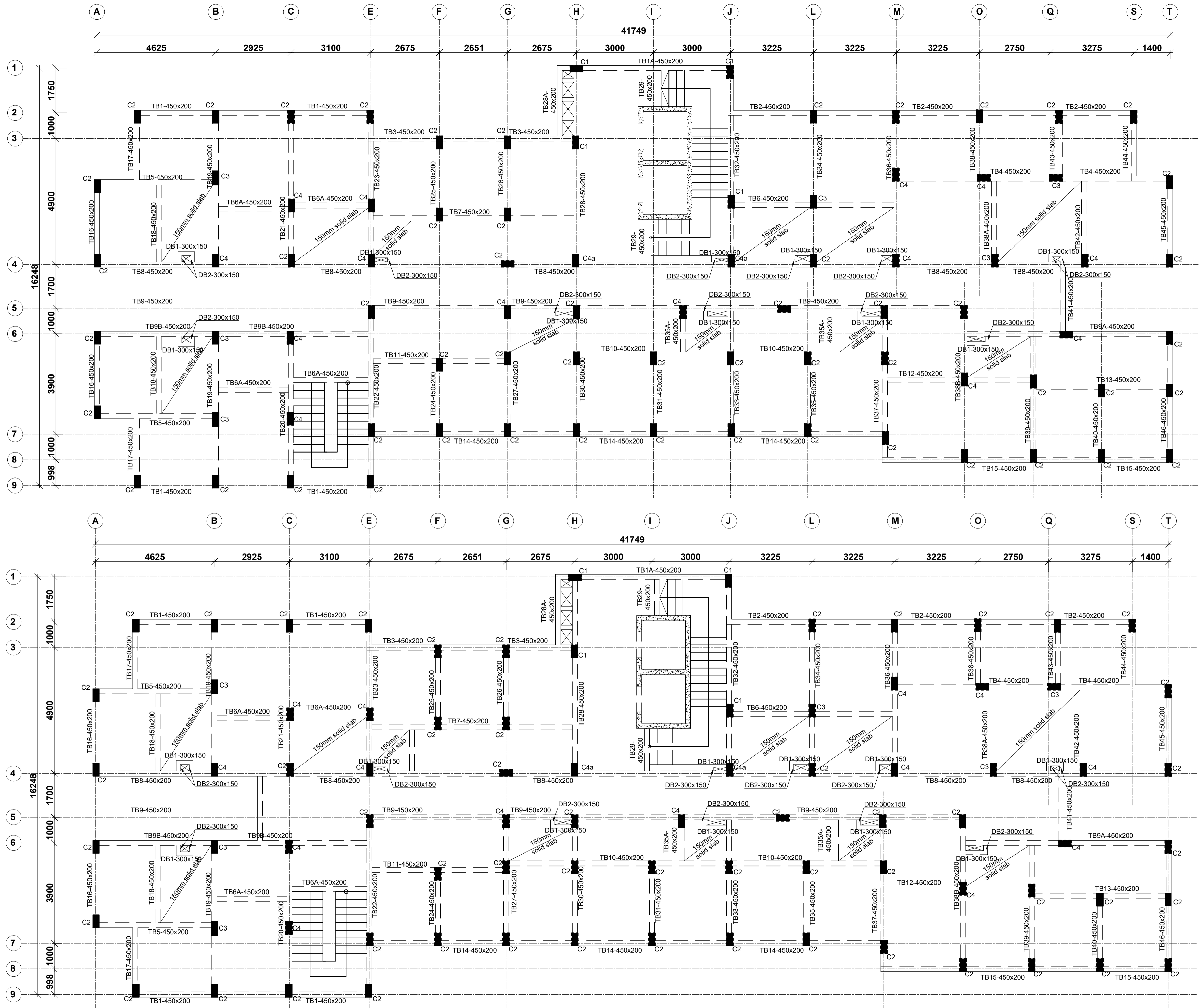

TYPICAL 1ST FLOOR LAYOUT  
130mm THICK SOLID SLAB UNLESS SPECIFIED OTHERWISE  
SCALE 1:75

TYPICAL 2ND & 9TH FLOOR LAYOUT  
130mm THICK SOLID SLAB UNLESS SPECIFIED OTHERWISE  
SCALE 1:75

**NOTE:**  
1. Foundations to be excavated to a minimum depth of 3.5m  
2. Introduce a 300x200 ground beam over all the foundation wallings  
3. All masonry units to be machine cut blocks

**NOTES**  
1. All dimensions are in millimetres unless otherwise stated.  
2. All reinforcements must be checked and approved by project structural engineer prior to concreting.  
3. All reinforced concrete to be Class 25 mix and blinding concrete to be Class 15 mix.  
4. Only figured dimensions to be taken from this drawing.  
5. Any discrepancy in dimensions to be reported to the project consultants i.e architect or engineer.

6. Symbols: T-TMT Rebars to BS 4461: T - Top face  
B - Bottom face  
7. Cover to reinforcement; Slabs - 20mm, Beams - 25mm, Columns - 40mm, Foundations - 50mm  
8. All structural steel be grade 43A.  
9. All welds are 6mm thick.  
10. All structural steel to be painted with anti-rust primer paint.

**Client**  
MINISTRY OF LANDS, PUBLIC WORKS, HOUSING AND URBAN DEVELOPMENT  
STATE DEPARTMENT FOR HOUSING AND URBAN DEVELOPMENT

**STRUCTURAL ENGINEER:**

Designed by: H.I.H  
Checked by: R.M.O  
Approved by: SECRETARY, HOUSING DEPARTMENT  
Date: 17TH APRIL 2024  
Scale: As shown  
Drawing Number: AHP-G+9-BLKA 05

**Project**  
PROPOSED AFFORDABLE HOUSING PROGRAM-G+9 GENERIC BLOCK A.  
**Title**  
TYPICAL FLOOR LAYOUTS

Revisions		
No.	Description	Date

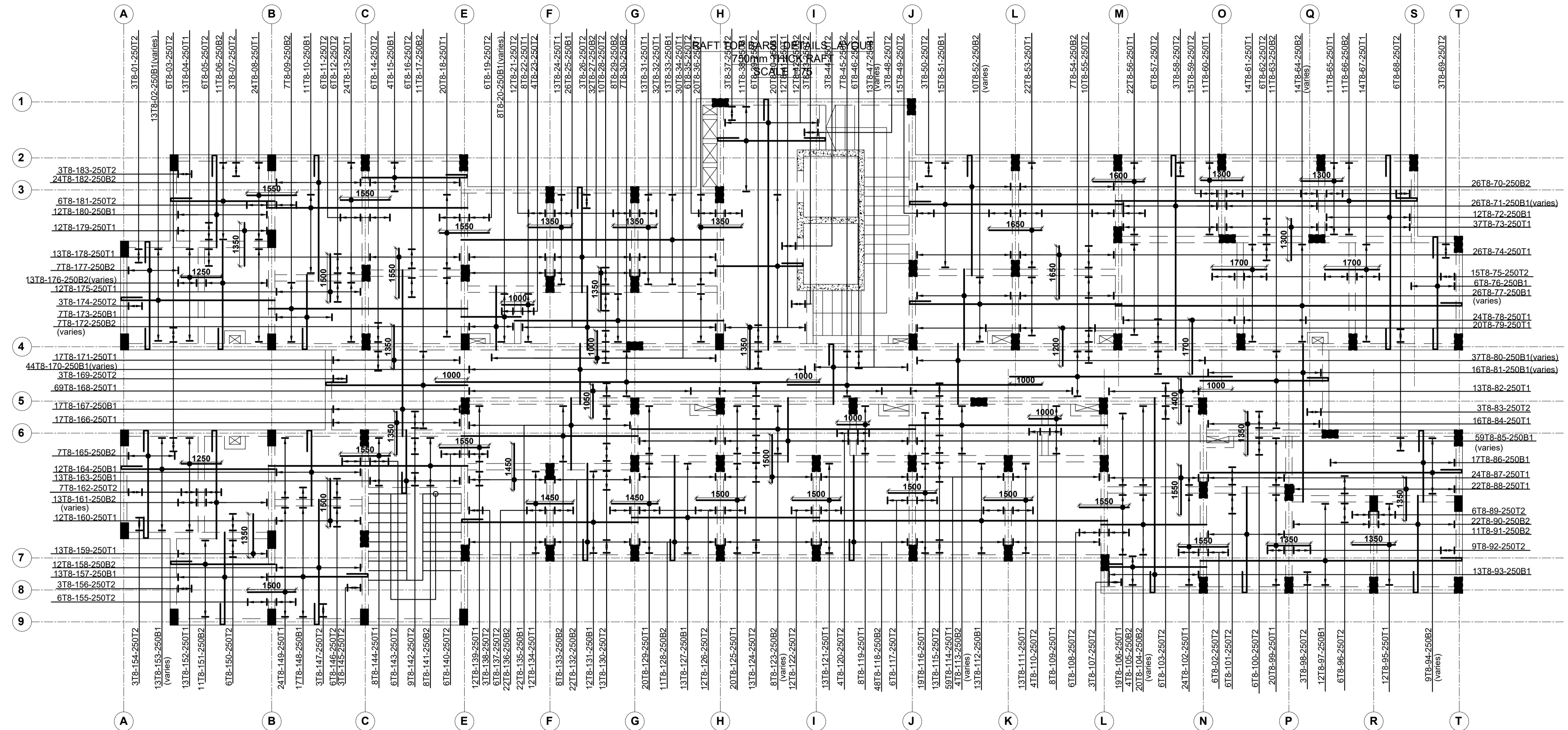

TYPICAL 1ST FLOOR SLAB DETAILS  
 130mm THICK SOLID SLAB UNLESS  
 SPECIFIED OTHERWISE  
 SCALE 1:75

**NOTE:**  
 1. Foundations to be excavated to a minimum depth of 3.5m  
 2. Introduce a 300x200 ground beam over all the foundation wallings  
 3. All masonry units to be machine cut blocks

**NOTES**  
 1. All dimensions are in millimetres unless otherwise stated.  
 2. All reinforcements must be checked and approved by project structural engineer prior to concreting.  
 3. All reinforced concrete to be Class 25 mix and blinding concrete to be Class 15 mix.  
 4. Only figured dimensions to be taken from this drawing.  
 5. Any discrepancy in dimensions to be reported to the project consultants i.e architect or engineer.

6. Symbols: T-TMT Rebars to BS 4461: T - Top face  
 B - Bottom face  
 7. Cover to reinforcement; Slabs - 20mm,  
 Beams - 25mm, Columns - 40mm, Foundations - 50mm  
 8. All structural steel be grade 43A.  
 9. All welds are 6mm thick.  
 10. All structural steel to be painted with anti-rust primer paint.

**Client**  
 MINISTRY OF LANDS, PUBLIC WORKS,  
 HOUSING AND URBAN DEVELOPMENT  
 STATE DEPARTMENT FOR HOUSING AND URBAN  
 DEVELOPMENT

**STRUCTURAL ENGINEER:**

Designed by: H.I.H  
 Checked by: R.M.O  
 Approved by: SECRETARY, HOUSING DEPARTMENT  
 Date: 17TH APRIL 2024  
 Scale: As shown  
 Drawing Number: AHP-G+9-BLKA 06

**Project**  
 PROPOSED AFFORDABLE HOUSING  
 PROGRAM-G+9 GENERIC BLOCK A.  
**Title**  
 TYPICAL 1ST FLOOR SLAB DETAILS

Revisions		
No.	Description	Date

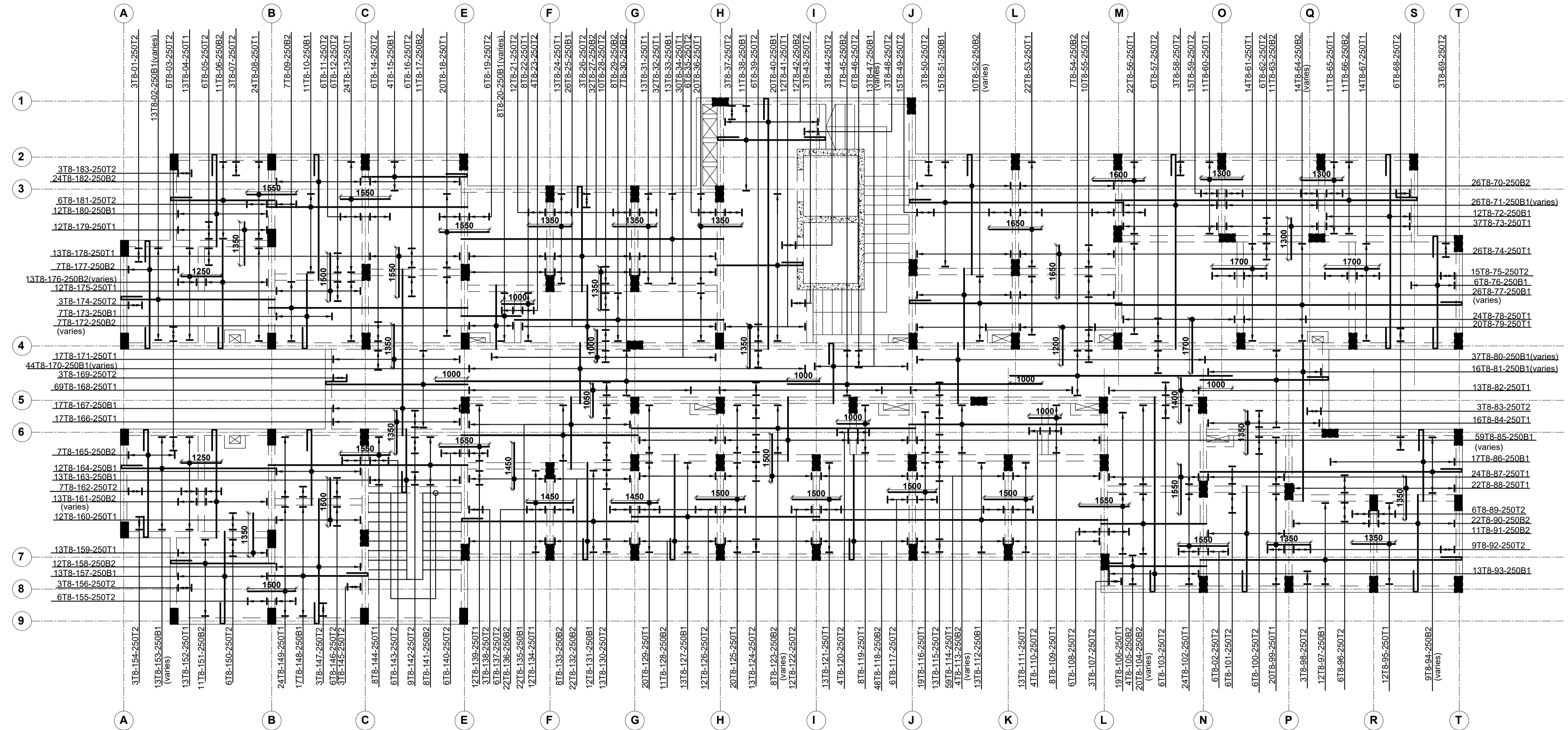

TYPICAL 2ND & 9TH FLOOR SLAB DETAILS  
 130mm THICK SOLID SLAB UNLESS  
 SPECIFIED OTHERWISE  
 SCALE 1:75

**NOTE:**

- Foundations to be excavated to a minimum depth of 3.5m
- Introduce a 300x200 ground beam over all the foundation wallings
- All masonry units to be machine cut blocks

**NOTES**

- All dimensions are in millimetres unless otherwise stated.
- All reinforcements must be checked and approved by project structural engineer prior to concreting.
- All reinforced concrete to be Class 25 mix and blinding concrete to be Class 15 mix.
- Only figured dimensions to be taken from this drawing.
- Any discrepancy in dimensions to be reported to the project consultants i.e architect or engineer.

- Symbols: T-TMT Rebars to BS 4461: T - Top face B - Bottom face
- Cover to reinforcement; Slabs - 20mm, Beams - 25mm, Columns - 40mm, Foundations - 50mm
- All structural steel be grade 43A.
- All welds are 6mm thick.
- All structural steel to be painted with anti-rust primer paint.

**Client**  
 MINISTRY OF LANDS, PUBLIC WORKS,  
 HOUSING AND URBAN DEVELOPMENT  
 STATE DEPARTMENT FOR HOUSING AND URBAN  
 DEVELOPMENT

**STRUCTURAL ENGINEER:**

Designed by: H.I.H Checked by: R.M.O  
 Approved by: SECRETARY, HOUSING DEPARTMENT  
 Date: 17TH APRIL 2024 Scale: As shown  
 Drawing Number: AHP-G+9-BLKA 07

**Project**  
 PROPOSED AFFORDABLE HOUSING  
 PROGRAM-G+9 GENERIC BLOCK A.  
**Title** TYPICAL 2ND & 9TH  
 FLOOR SLAB DETAILS

Revisions		
No.	Description	Date

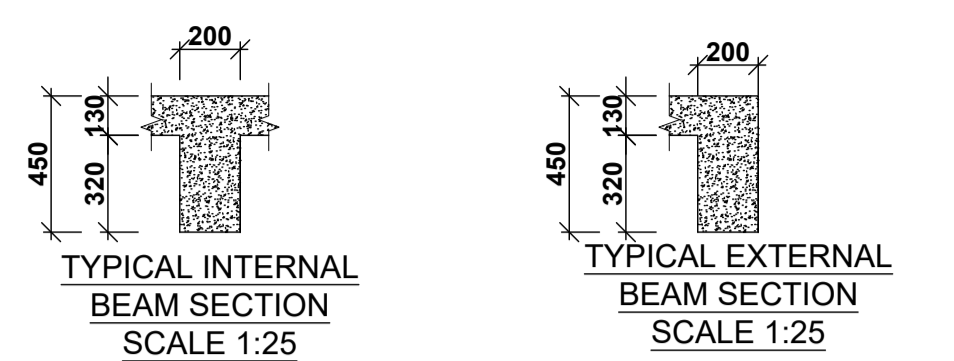
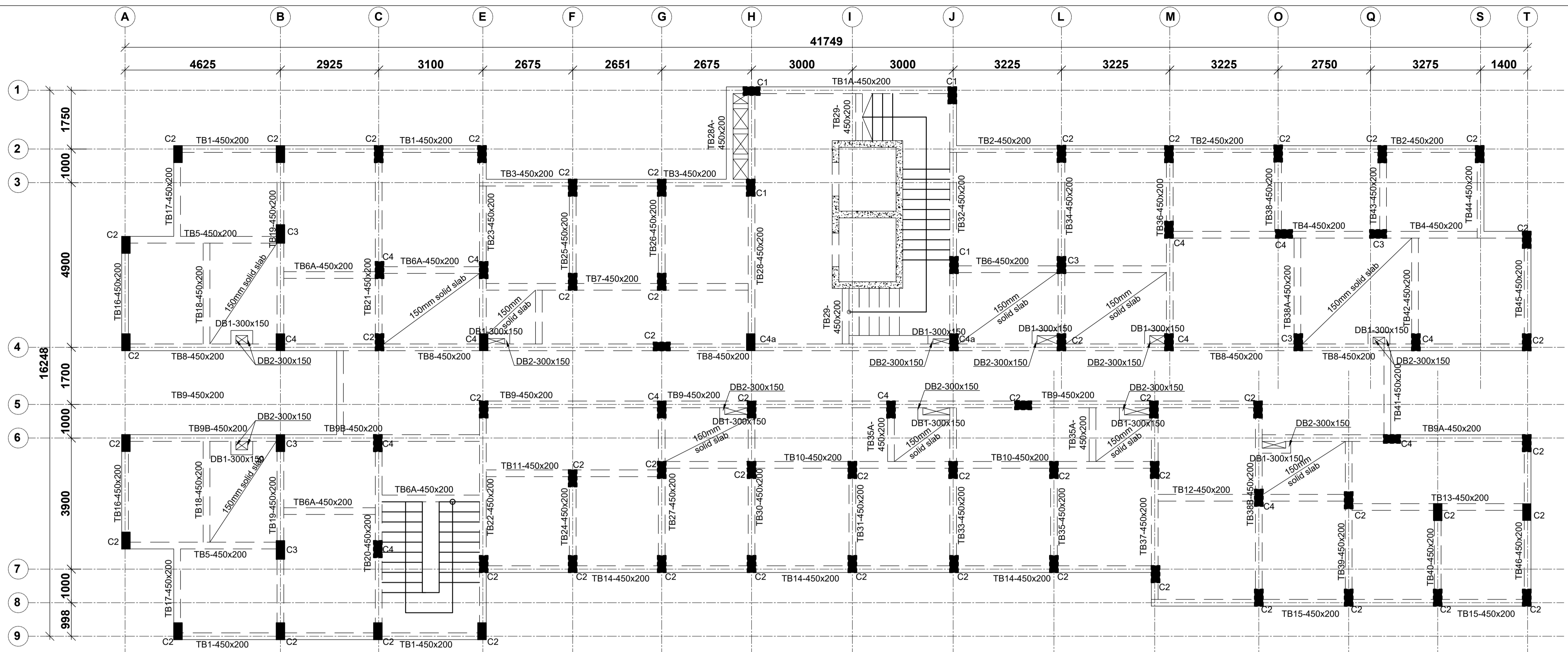

TYPICAL 3RD & 7TH FLOOR LAYOUT  
130mm THICK SOLID SLAB UNLESS SPECIFIED OTHERWISE  
SCALE 1:75

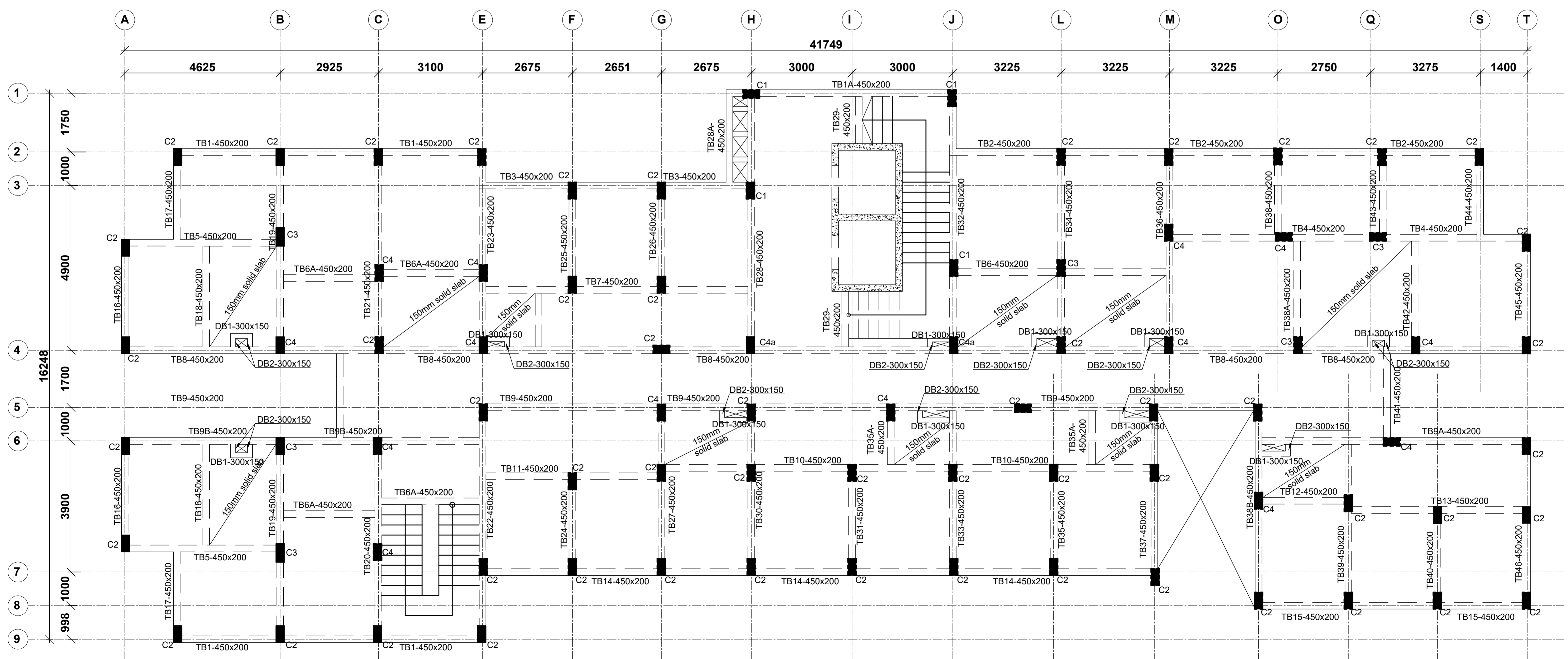

TYPICAL 4TH & 8TH FLOOR LAYOUT  
130mm THICK SOLID SLAB UNLESS SPECIFIED OTHERWISE  
SCALE 1:75

**NOTE:**  
1. Foundations to be excavated to a minimum depth of 3.5m  
2. Introduce a 300x200 ground beam over all the foundation wallings  
3. All masonry units to be machine cut blocks

**NOTES**  
1. All dimensions are in millimetres unless otherwise stated.  
2. All reinforcements must be checked and approved by project structural engineer prior to concreting.  
3. All reinforced concrete to be Class 25 mix and blinding concrete to be Class 15 mix.  
4. Only figured dimensions to be taken from this drawing.  
5. Any discrepancy in dimensions to be reported to the project consultants i.e architect or engineer.

6. Symbols: T-TMT Rebars to BS 4461: T - Top face  
B - Bottom face  
7. Cover to reinforcement; Slabs - 20mm,  
Beams - 25mm, Columns - 40mm, Foundations - 50mm  
8. All structural steel be grade 43A.  
9. All welds are 6mm thick.  
10. All structural steel to be painted with anti-rust primer paint.

**Client**  
MINISTRY OF LANDS, PUBLIC WORKS,  
HOUSING AND URBAN DEVELOPMENT  
STATE DEPARTMENT FOR HOUSING AND URBAN  
DEVELOPMENT

**STRUCTURAL ENGINEER:**

Designed by: H.I.H Checked by: R.M.O  
Approved by: SECRETARY, HOUSING DEPARTMENT  
Date: 17TH APRIL 2024 Scale: As shown  
Drawing Number: AHP-G+9-BLKA 08

**Project**  
PROPOSED AFFORDABLE HOUSING  
PROGRAM-G+9 GENERIC BLOCK A.  
**Title**  
TYPICAL FLOOR LAYOUTS

Revisions		
No.	Description	Date

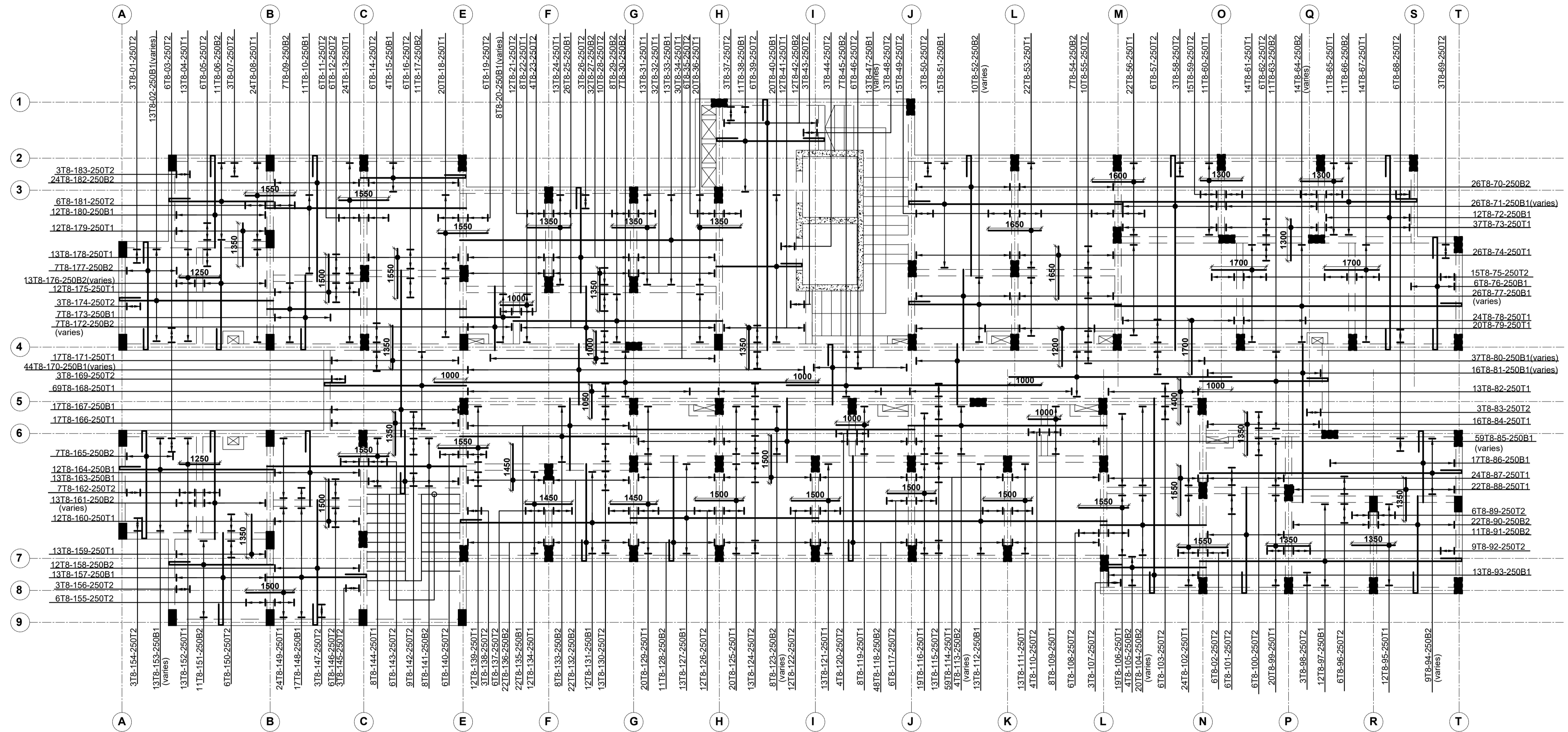

TYPICAL 3RD & 7TH FLOOR SLAB DETAILS  
 130mm THICK SOLID SLAB UNLESS  
 SPECIFIED OTHERWISE  
 SCALE 1:75

**NOTE:**

- Foundations to be excavated to a minimum depth of 3.5m
- Introduce a 300x200 ground beam over all the foundation wallings
- All masonry units to be machine cut blocks

**NOTES**

- All dimensions are in millimetres unless otherwise stated.
- All reinforcements must be checked and approved by project structural engineer prior to concreting.
- All reinforced concrete to be Class 25 mix and blinding concrete to be Class 15 mix.
- Only figured dimensions to be taken from this drawing.
- Any discrepancy in dimensions to be reported to the project consultants i.e architect or engineer.

- Symbols: T-TMT Rebars to BS 4461: T - Top face  
B - Bottom face
- Cover to reinforcement; Slabs - 20mm,  
Beams - 25mm, Columns - 40mm, Foundations - 50mm
- All structural steel be grade 43A.
- All welds are 6mm thick.
- All structural steel to be painted with anti-rust primer paint.

**Client**  
 MINISTRY OF LANDS, PUBLIC WORKS,  
 HOUSING AND URBAN DEVELOPMENT  
 STATE DEPARTMENT FOR HOUSING AND URBAN  
 DEVELOPMENT

**STRUCTURAL ENGINEER:**

Designed by: H.I.H      Checked by: R.M.O  
 Approved by: SECRETARY, HOUSING DEPARTMENT  
 Date: 17TH APRIL 2024      Scale: As shown  
 Drawing Number: AHP-G+9-BLKA 09

**Project**  
 PROPOSED AFFORDABLE HOUSING  
 PROGRAM-G+9 GENERIC BLOCK A.  
**Title** TYPICAL 3RD & 7TH  
 FLOOR SLAB DETAILS

Revisions		
No.	Description	Date

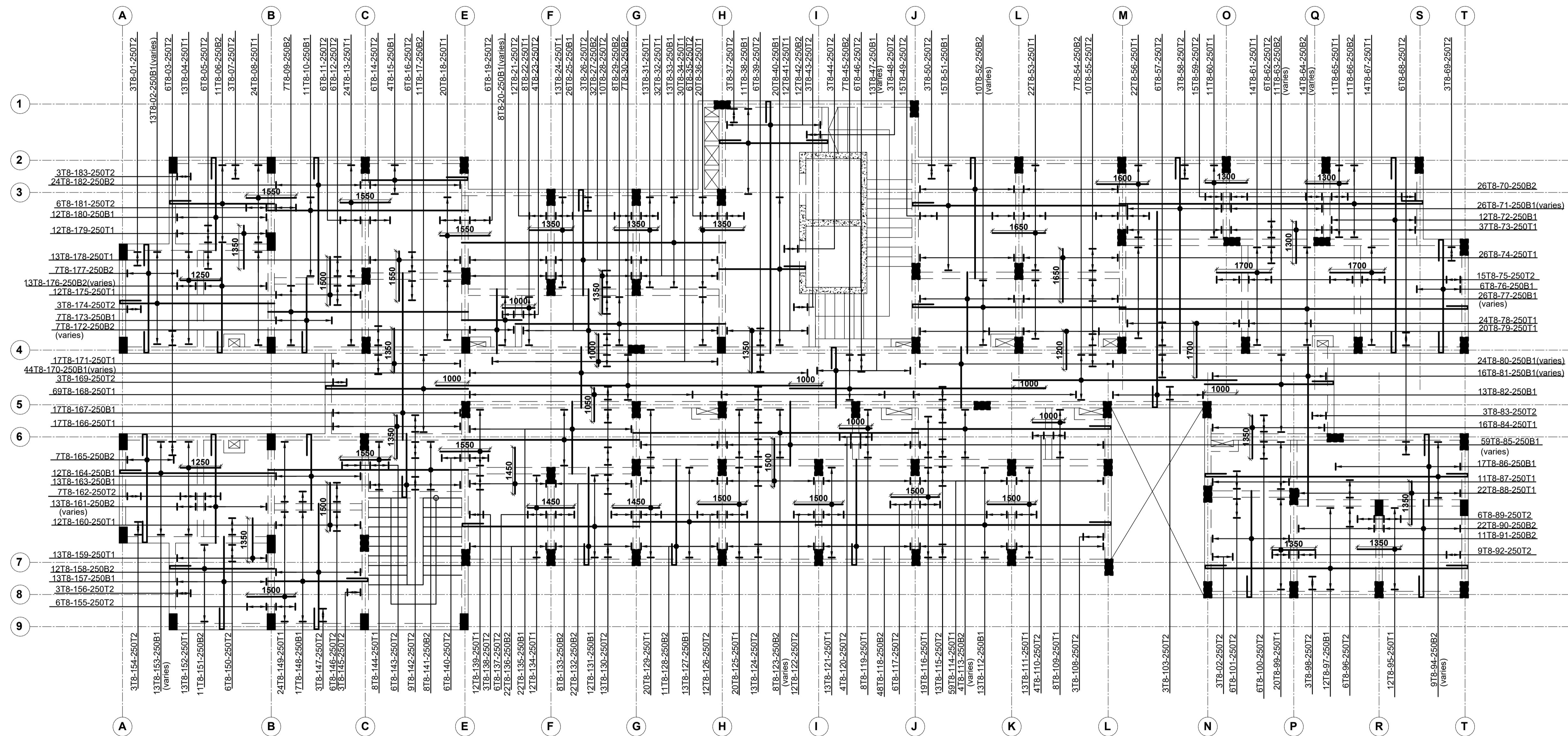

TYPICAL 4TH & 8TH FLOOR SLAB DETAILS  
 130mm THICK SOLID SLAB UNLESS  
 SPECIFIED OTHERWISE  
 SCALE 1:75

**NOTE:**

1. Foundations to be excavated to a minimum depth of 3.5m
2. Introduce a 300x200 ground beam over all the foundation wallings
3. All masonry units to be machine cut blocks

- NOTES**
1. All dimensions are in millimetres unless otherwise stated.
  2. All reinforcements must be checked and approved by project structural engineer prior to concreting.
  3. All reinforced concrete to be Class 25 mix and blinding concrete to be Class 15 mix.
  4. Only figured dimensions to be taken from this drawing.
  5. Any discrepancy in dimensions to be reported to the project consultants i.e. architect or engineer.

6. Symbols: T-TMT Rebars to BS 4461: T - Top face  
B - Bottom face
7. Cover to reinforcement; Slabs - 20mm,  
Beams - 25mm, Columns - 40mm, Foundations - 50mm
8. All structural steel be grade 43A.
9. All welds are 6mm thick.
10. All structural steel to be painted with anti-rust primer paint.

**Client**  
 MINISTRY OF LANDS, PUBLIC WORKS,  
 HOUSING AND URBAN DEVELOPMENT  
 STATE DEPARTMENT FOR HOUSING AND URBAN  
 DEVELOPMENT

**STRUCTURAL ENGINEER:**

Designed by: H.I.H      Checked by: R.M.O  
 Approved by: SECRETARY, HOUSING DEPARTMENT  
 Date: 17TH APRIL 2024      Scale: As shown  
 Drawing Number: AHP-G+9-BLKA 10

**Project**  
 PROPOSED AFFORDABLE HOUSING  
 PROGRAM-G+9 GENERIC BLOCK A.  
**Title** TYPICAL 4TH & 8TH  
 FLOOR SLAB DETAILS

Revisions		
No.	Description	Date



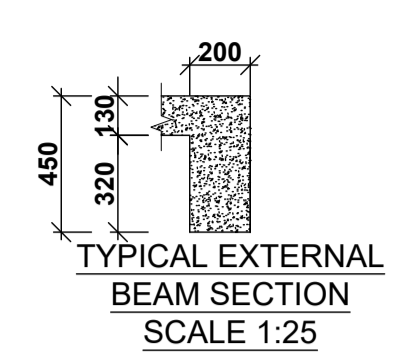
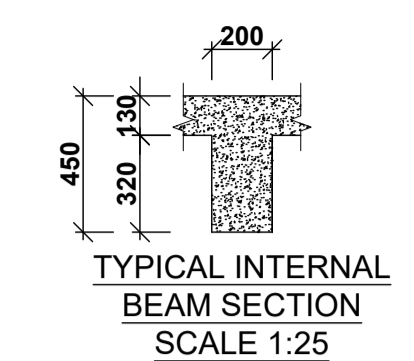
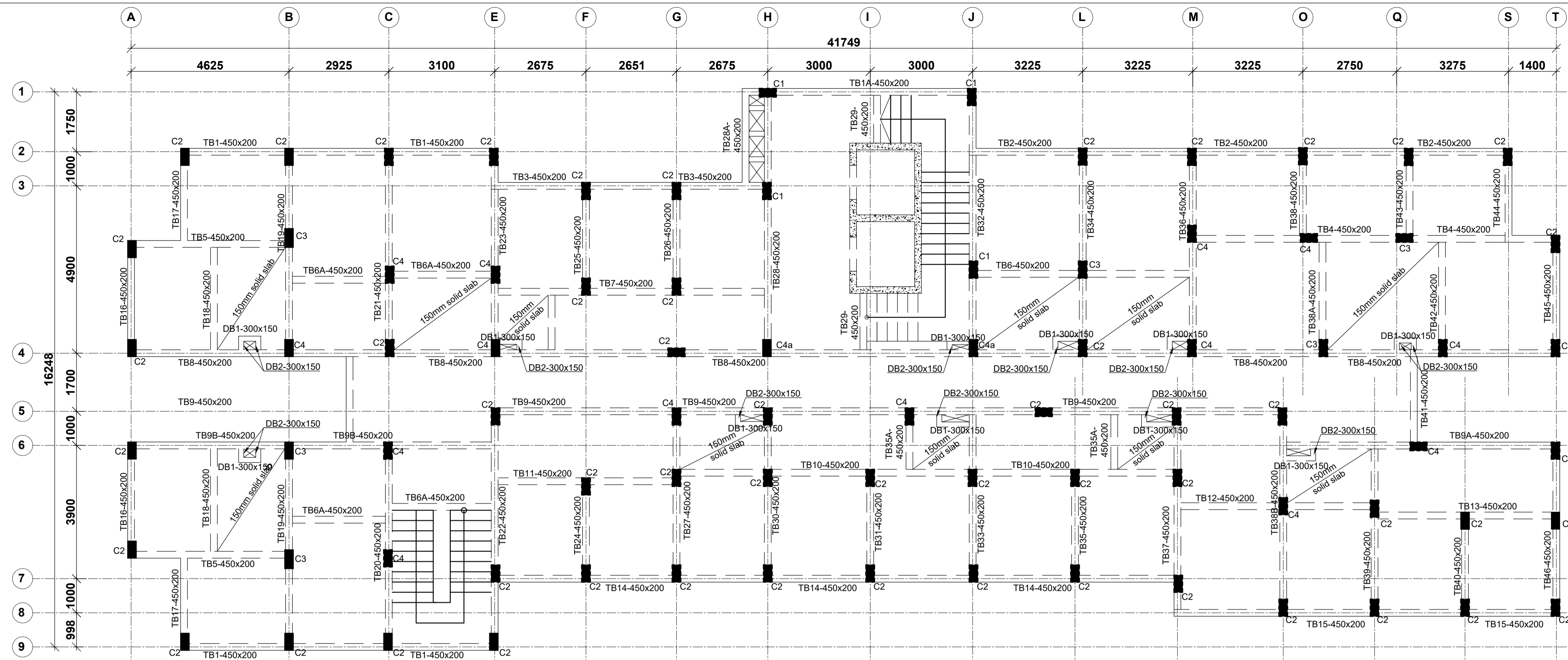

TYPICAL 5TH FLOOR LAYOUT  
130mm THICK SOLID SLAB UNLESS SPECIFIED OTHERWISE  
SCALE 1:75

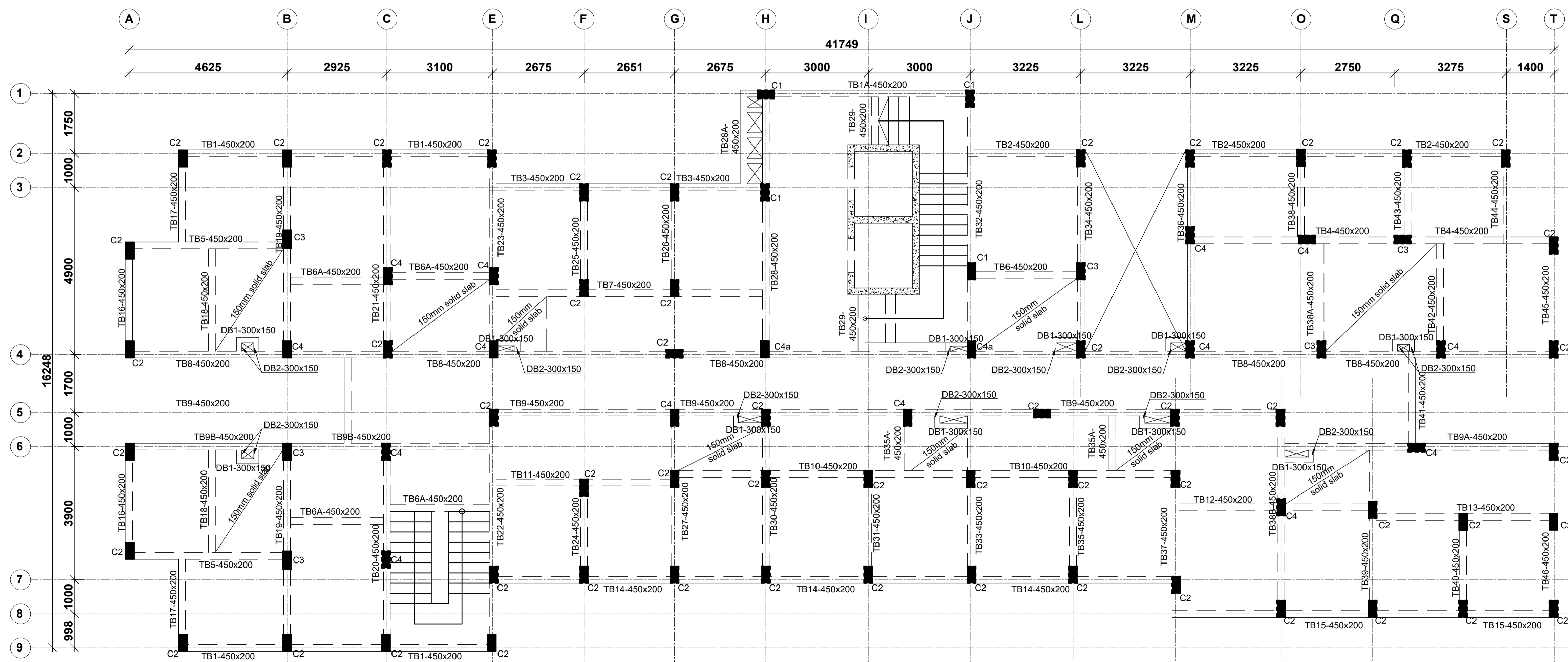

TYPICAL 6TH FLOOR LAYOUT  
130mm THICK SOLID SLAB UNLESS SPECIFIED OTHERWISE  
SCALE 1:75

**NOTE:**  
1. Foundations to be excavated to a minimum depth of 3.5m  
2. Introduce a 300x200 ground beam over all the foundation wallings  
3. All masonry units to be machine cut blocks

**NOTES**  
1. All dimensions are in millimetres unless otherwise stated.  
2. All reinforcements must be checked and approved by project structural engineer prior to concreting.  
3. All reinforced concrete to be Class 25 mix and blinding concrete to be Class 15 mix.  
4. Only figured dimensions to be taken from this drawing.  
5. Any discrepancy in dimensions to be reported to the project consultants i.e architect or engineer.

6. Symbols: T-TMT Rebars to BS 4461: T - Top face B - Bottom face  
7. Cover to reinforcement; Slabs - 20mm, Beams - 25mm, Columns - 40mm, Foundations - 50mm  
8. All structural steel be grade 43A.  
9. All welds are 6mm thick.  
10. All structural steel to be painted with anti-rust primer paint.

**Client**  
MINISTRY OF LANDS, PUBLIC WORKS, HOUSING AND URBAN DEVELOPMENT  
STATE DEPARTMENT FOR HOUSING AND URBAN DEVELOPMENT

**STRUCTURAL ENGINEER:**

Designed by: H.I.H Checked by: R.M.O  
Approved by: SECRETARY, HOUSING DEPARTMENT  
Date: 17TH APRIL 2024 Scale: As shown  
Drawing Number: AHP-G+9-BLKA 11

**Project**  
PROPOSED AFFORDABLE HOUSING PROGRAM-G+9 GENERIC BLOCK A.  
**Title**  
TYPICAL FLOOR LAYOUTS

Revisions		
No.	Description	Date

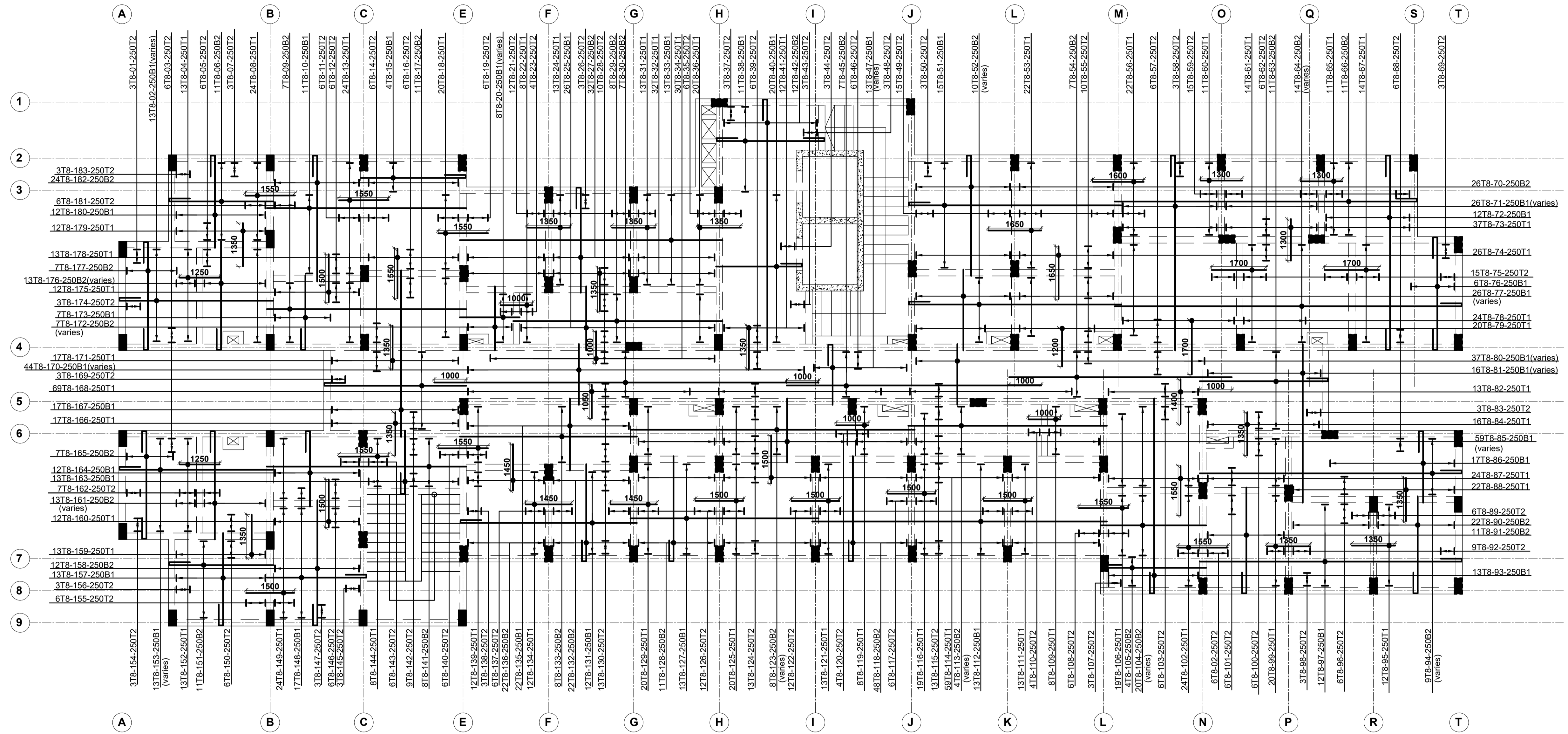

TYPICAL 5TH FLOOR SLAB DETAILS  
 130mm THICK SOLID SLAB UNLESS  
 SPECIFIED OTHERWISE  
 SCALE 1:75

**NOTE:**

- Foundations to be excavated to a minimum depth of 3.5m
- Introduce a 300x200 ground beam over all the foundation wallings
- All masonry units to be machine cut blocks

**NOTES**

- All dimensions are in millimetres unless otherwise stated.
- All reinforcements must be checked and approved by project structural engineer prior to concreting.
- All reinforced concrete to be Class 25 mix and blinding concrete to be Class 15 mix.
- Only figured dimensions to be taken from this drawing.
- Any discrepancy in dimensions to be reported to the project consultants i.e architect or engineer.

6. Symbols: T-TMT Rebars to BS 4461: T - Top face  
 B - Bottom face

- Cover to reinforcement; Slabs - 20mm, Beams - 25mm, Columns - 40mm, Foundations - 50mm
- All structural steel be grade 43A.
- All welds are 6mm thick.
- All structural steel to be painted with anti-rust primer paint.

**Client**  
 MINISTRY OF LANDS, PUBLIC WORKS,  
 HOUSING AND URBAN DEVELOPMENT  
 STATE DEPARTMENT FOR HOUSING AND URBAN  
 DEVELOPMENT

**STRUCTURAL ENGINEER:**

Designed by: H.I.H      Checked by: R.M.O  
 Approved by: SECRETARY, HOUSING DEPARTMENT  
 Date: 17TH APRIL 2024      Scale: As shown  
 Drawing Number: AHP-G+9-BLKA 12

**Project**  
 PROPOSED AFFORDABLE HOUSING  
 PROGRAM-G+9 GENERIC BLOCK A.  
**Title**  
 TYPICAL 5TH FLOOR SLAB DETAILS

Revisions		
No.	Description	Date

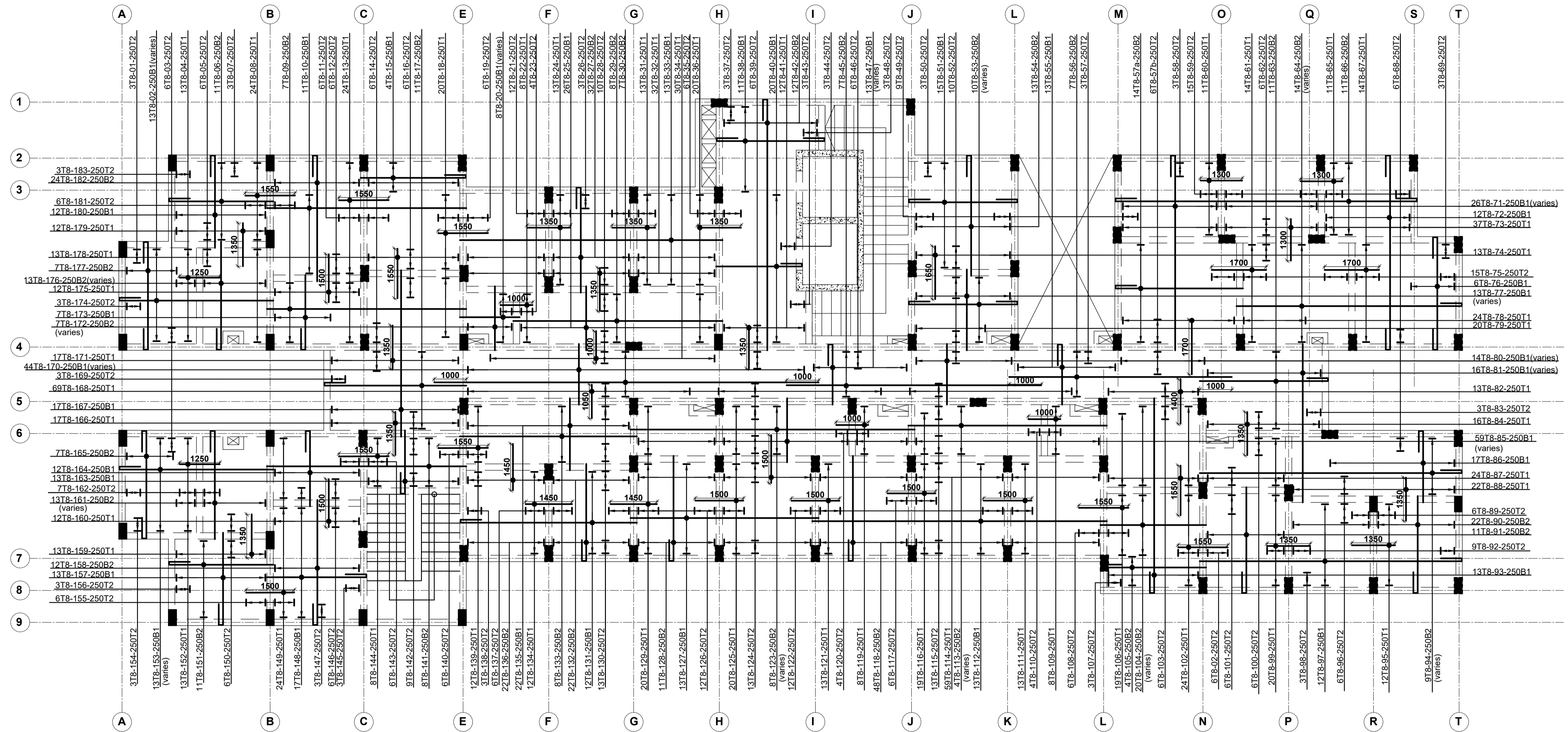

TYPICAL 6TH FLOOR SLAB DETAILS  
 130mm THICK SOLID SLAB UNLESS  
 SPECIFIED OTHERWISE  
 SCALE 1:75

**NOTE:**  
 1. Foundations to be excavated to a minimum depth of 3.5m  
 2. Introduce a 300x200 ground beam over all the foundation wallings  
 3. All masonry units to be machine cut blocks

**NOTES**  
 1. All dimensions are in millimetres unless otherwise stated.  
 2. All reinforcements must be checked and approved by project structural engineer prior to concreting.  
 3. All reinforced concrete to be Class 25 mix and blinding concrete to be Class 15 mix.  
 4. Only figured dimensions to be taken from this drawing.  
 5. Any discrepancy in dimensions to be reported to the project consultants i.e architect or engineer.

6. Symbols: T-TMT Rebars to BS 4461: T - Top face  
 B - Bottom face  
 7. Cover to reinforcement; Slabs - 20mm,  
 Beams - 25mm, Columns - 40mm, Foundations - 50mm  
 8. All structural steel be grade 43A.  
 9. All welds are 6mm thick.  
 10. All structural steel to be painted with anti-rust primer paint.

**Client**  
 MINISTRY OF LANDS, PUBLIC WORKS,  
 HOUSING AND URBAN DEVELOPMENT  
 STATE DEPARTMENT FOR HOUSING AND URBAN  
 DEVELOPMENT

**STRUCTURAL ENGINEER:**

Designed by: H.I.H      Checked by: R.M.O  
 Approved by: SECRETARY, HOUSING DEPARTMENT  
 Date: 17TH APRIL 2024      Scale: As shown  
 Drawing Number: AHP-G+9-BLKA 13

**Project**  
 PROPOSED AFFORDABLE HOUSING  
 PROGRAM-G+9 GENERIC BLOCK A.  
**Title**  
 TYPICAL 6TH FLOOR SLAB DETAILS

Revisions		
No.	Description	Date

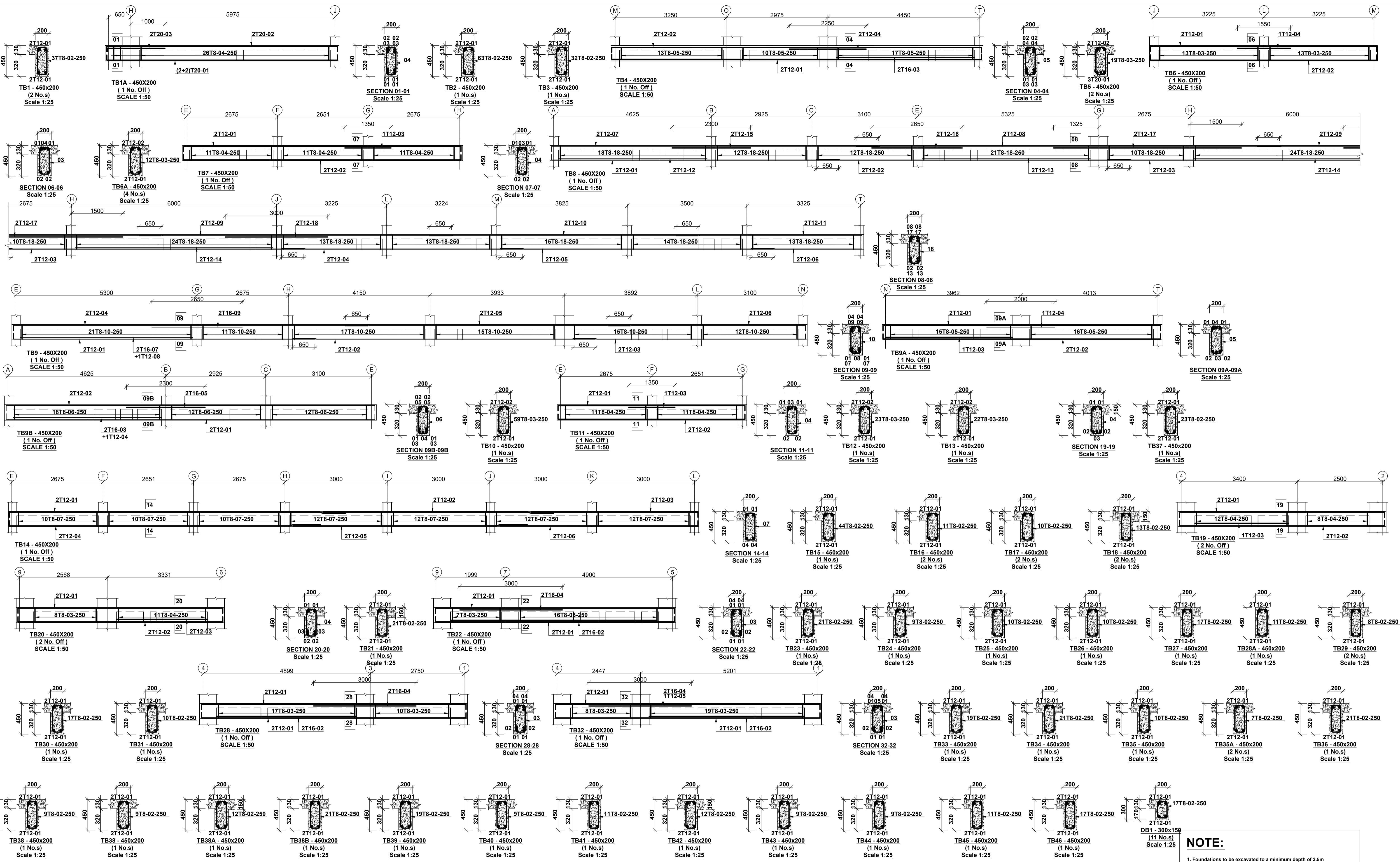

**NOTE:**

1. Foundations to be excavated to a minimum depth of 3.5m
2. Introduce a 300x200 ground beam over all the foundation wallings
3. All masonry units to be machine cut blocks

**NOTES**

1. All dimensions are in millimetres unless otherwise stated.
2. All reinforcements must be checked and approved by project structural engineer prior to concreting.
3. All reinforced concrete to be Class 25 mix and blinding concrete to be Class 15 mix.
4. Only figured dimensions to be taken from this drawing.
5. Any discrepancy in dimensions to be reported to the project consultants i.e architect or engineer.

6. Symbols: T-TMT Rebars to BS 4461: T - Top face  
B - Bottom face
7. Cover to reinforcement; Slabs - 20mm,  
Beams - 25mm, Columns - 40mm, Foundations - 50mm
8. All structural steel be grade 43A.
9. All welds are 6mm thick.
10. All structural steel to be painted with anti-rust primer paint.

**Client**  
**MINISTRY OF LANDS, PUBLIC WORKS,  
HOUSING AND URBAN DEVELOPMENT**  
STATE DEPARTMENT FOR HOUSING AND URBAN  
DEVELOPMENT

**STRUCTURAL ENGINEER:**

Designed by: H.I.H      Checked by: R.M.O  
Approved by: SECRETARY, HOUSING DEPARTMENT  
Date: 17TH APRIL 2024      Scale: As shown  
Drawing Number: AHP-G+14-BLKA 14

**Project**  
**PROPOSED AFFORDABLE HOUSING  
PROGRAM-G+9 GENERIC BLOCK A.**  
**Title**  
**TYPICAL FLOOR BEAMS DETAILS.**

Revisions		
No.	Description	Date

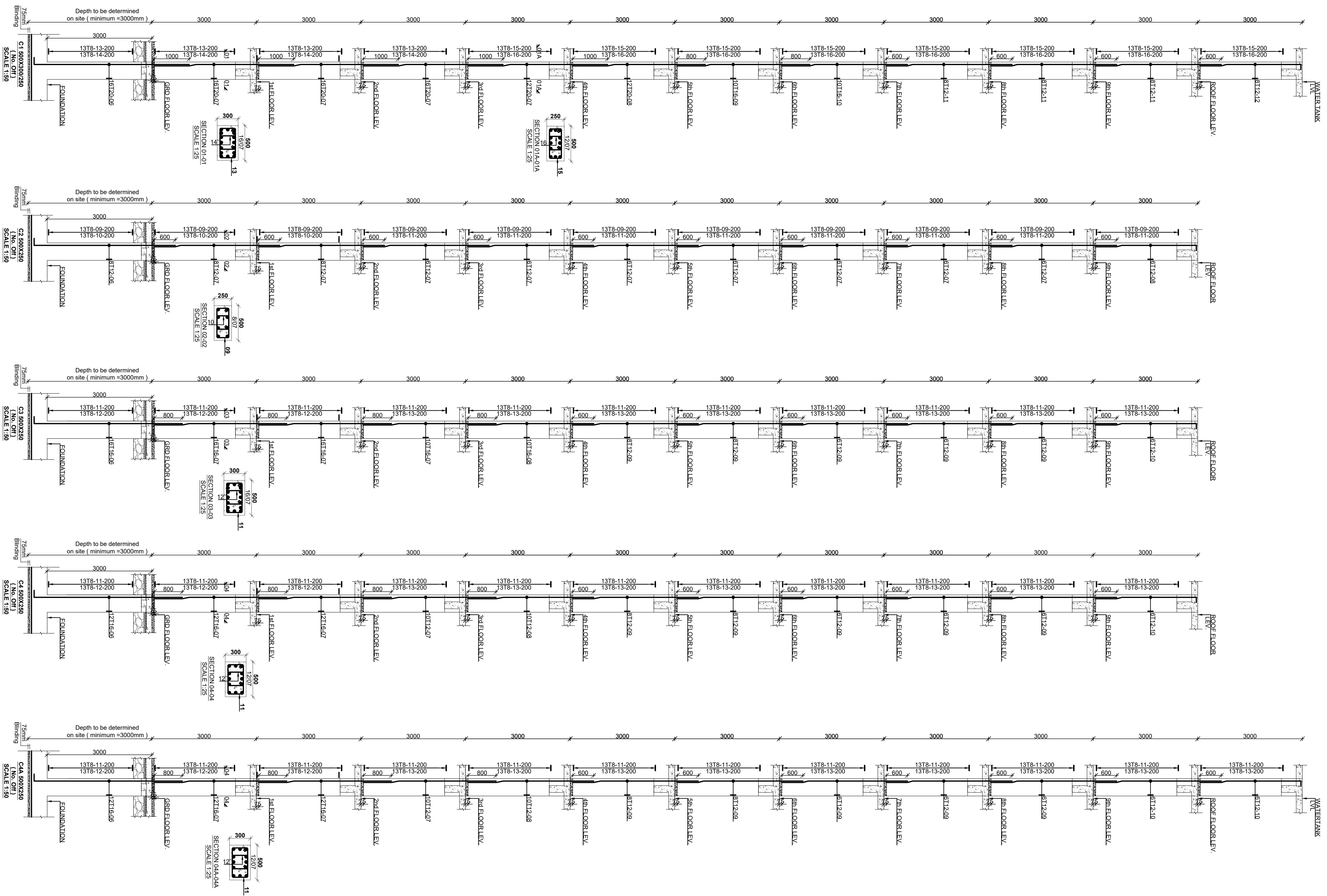

**NOTE:**  
 1. Foundations to be excavated to a minimum depth of 3.5m  
 2. Introduce a 300x200 ground beam over all the foundation walls  
 3. All masonry units to be machine cut bricks

**NOTES**  
 1. All dimensions are in millimetres unless otherwise stated.  
 2. All reinforcements must be checked and approved by project structural engineer prior to concreting.  
 3. All reinforced concrete to be Class 25 mix and blinding concrete to be Class 15 mix.  
 4. Only figured dimensions to be taken from this drawing.  
 5. Any discrepancy in dimensions to be reported to the project consultants i.e architect or engineer.

6. Symbols: T-TMT Rebars to BS 4461: T - Top face  
 B - Bottom face  
 7. Cover to reinforcement; Slabs - 20mm,  
 Beams - 25mm, Columns - 40mm, Foundations - 50mm  
 8. All structural steel be grade 43A.  
 9. All welds are 6mm thick.  
 10. All structural steel to be painted with anti-rust primer paint.

**Client**  
 MINISTRY OF LANDS, PUBLIC WORKS,  
 HOUSING AND URBAN DEVELOPMENT  
 STATE DEPARTMENT FOR HOUSING AND URBAN  
 DEVELOPMENT

**STRUCTURAL ENGINEER:**

Designed by: H.I.H      Checked by: R.M.O  
 Approved by: SECRETARY, HOUSING DEPARTMENT  
 Date: 17TH APRIL 2024      Scale: As shown  
 Drawing Number: AHP-G+9-BLKA 15

**Project**  
 PROPOSED AFFORDABLE HOUSING  
 PROGRAM-G+9 GENERIC BLOCK A.  
**Title**  
 COLUMN DETAILS

Revisions		
No.	Description	Date

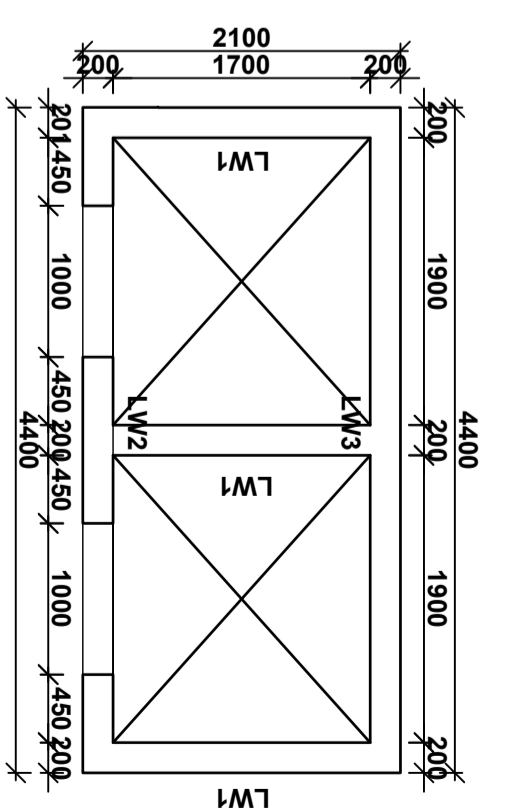
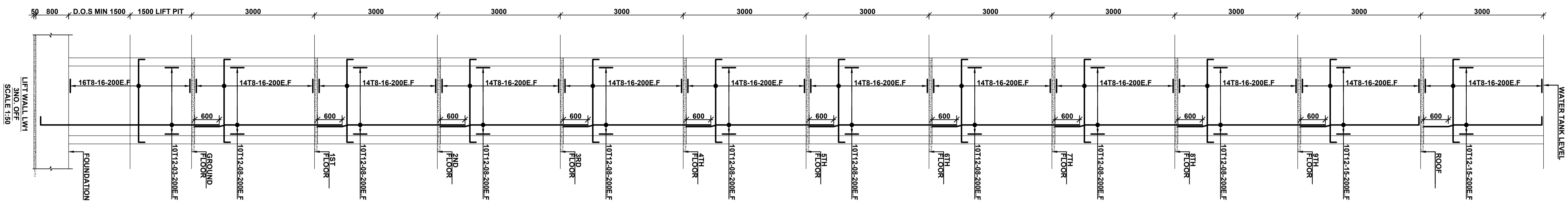
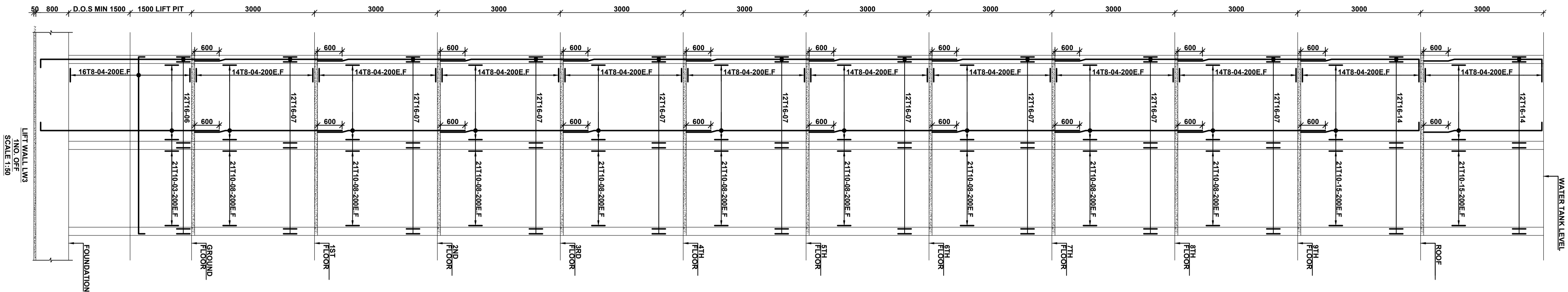
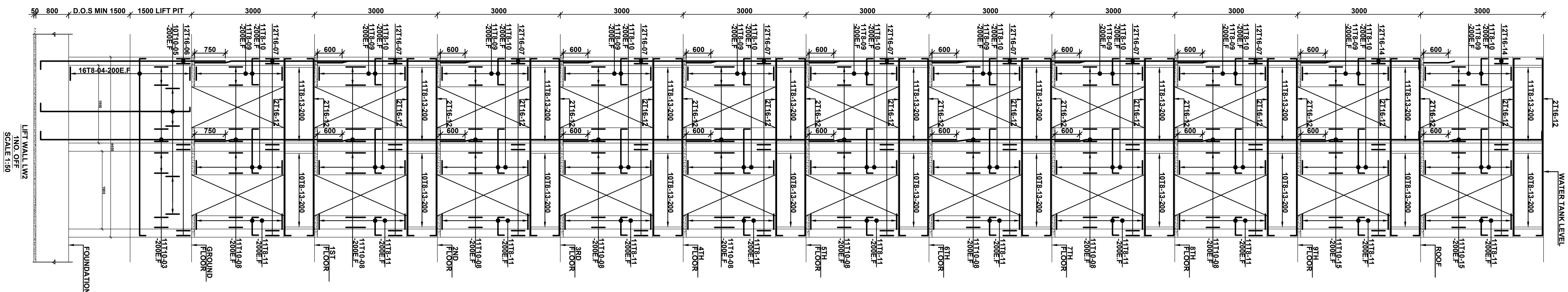

**NOTES**

- All dimensions are in millimetres unless otherwise stated.
- All reinforcements must be checked and approved by project structural engineer prior to concreting.
- All reinforced concrete to be Class 25 mix and blinding concrete to be Class 15 mix.
- Only figured dimensions to be taken from this drawing.
- Any discrepancy in dimensions to be reported to the project consultants i.e. architect or engineer.

6. Symbols: T-TMT Rebars to BS 4461: T - Top face  
B - Bottom face

- Cover to reinforcement; Slabs - 20mm, Beams - 25mm, Columns - 40mm, Foundations - 50mm
- All structural steel be grade 43A.
- All welds are 6mm thick.
- All structural steel to be painted with anti-rust primer paint.

**Client**  
 MINISTRY OF LANDS, PUBLIC WORKS,  
 HOUSING AND URBAN DEVELOPMENT  
 STATE DEPARTMENT FOR HOUSING AND URBAN  
 DEVELOPMENT

**STRUCTURAL ENGINEER:**

Designed by: H.I.H      Checked by: R.M.O  
 Approved by: SECRETARY, HOUSING DEPARTMENT  
 Date: 17TH APRIL 2024      Scale: As shown  
 Drawing Number: AHP-G+9-BLKA 16

**Project**  
 PROPOSED AFFORDABLE HOUSING  
 PROGRAM-G+9 GENERIC BLOCK A.  
**Title**  
 LIFT WALL DETAILS

Revisions		
No.	Description	Date

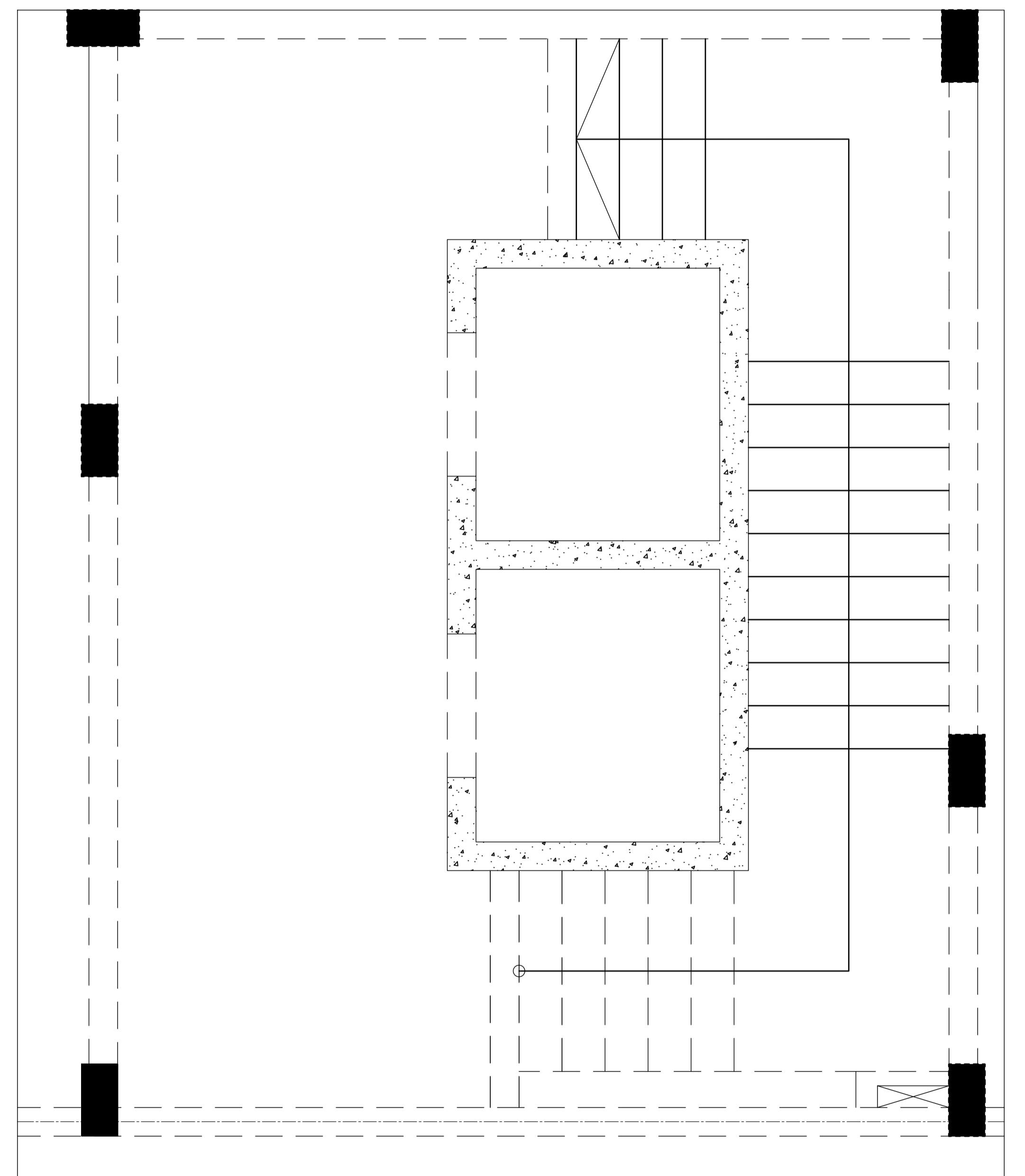
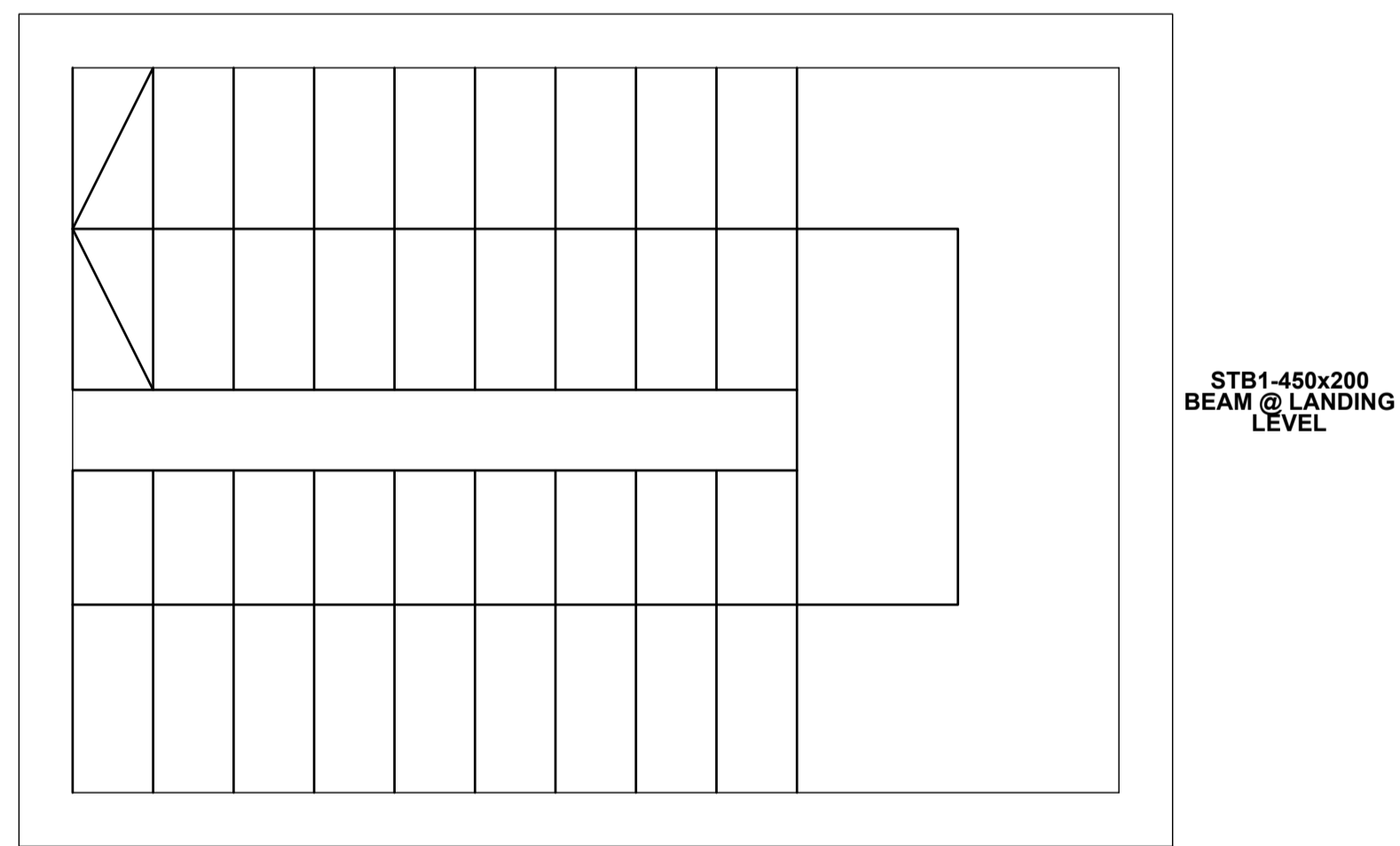
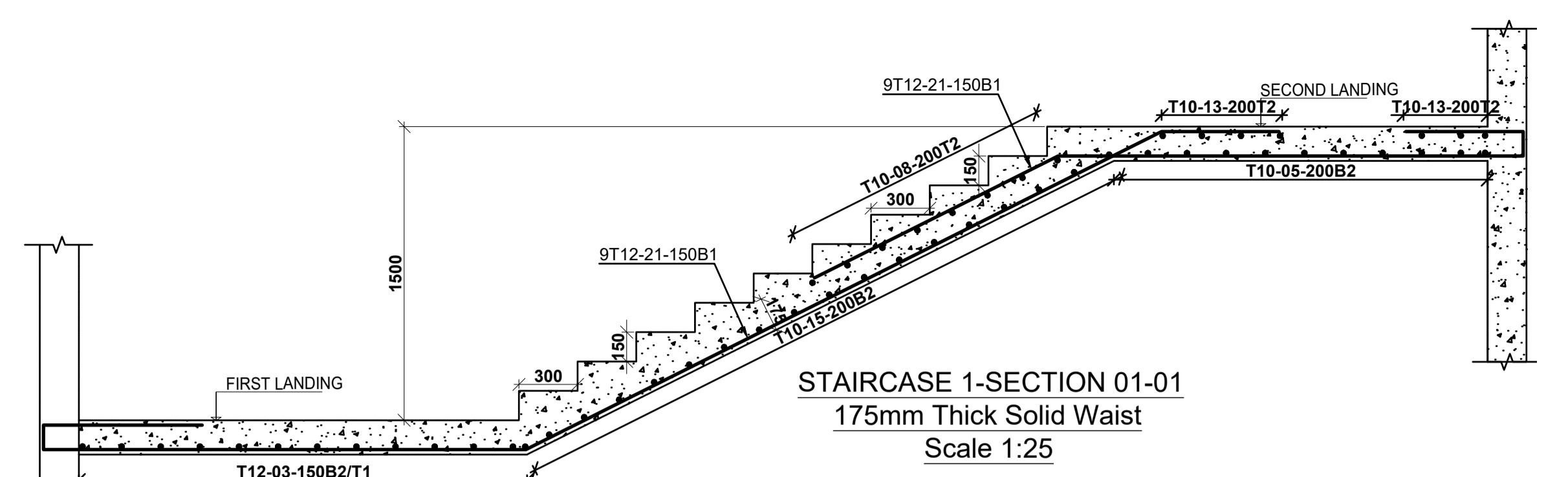
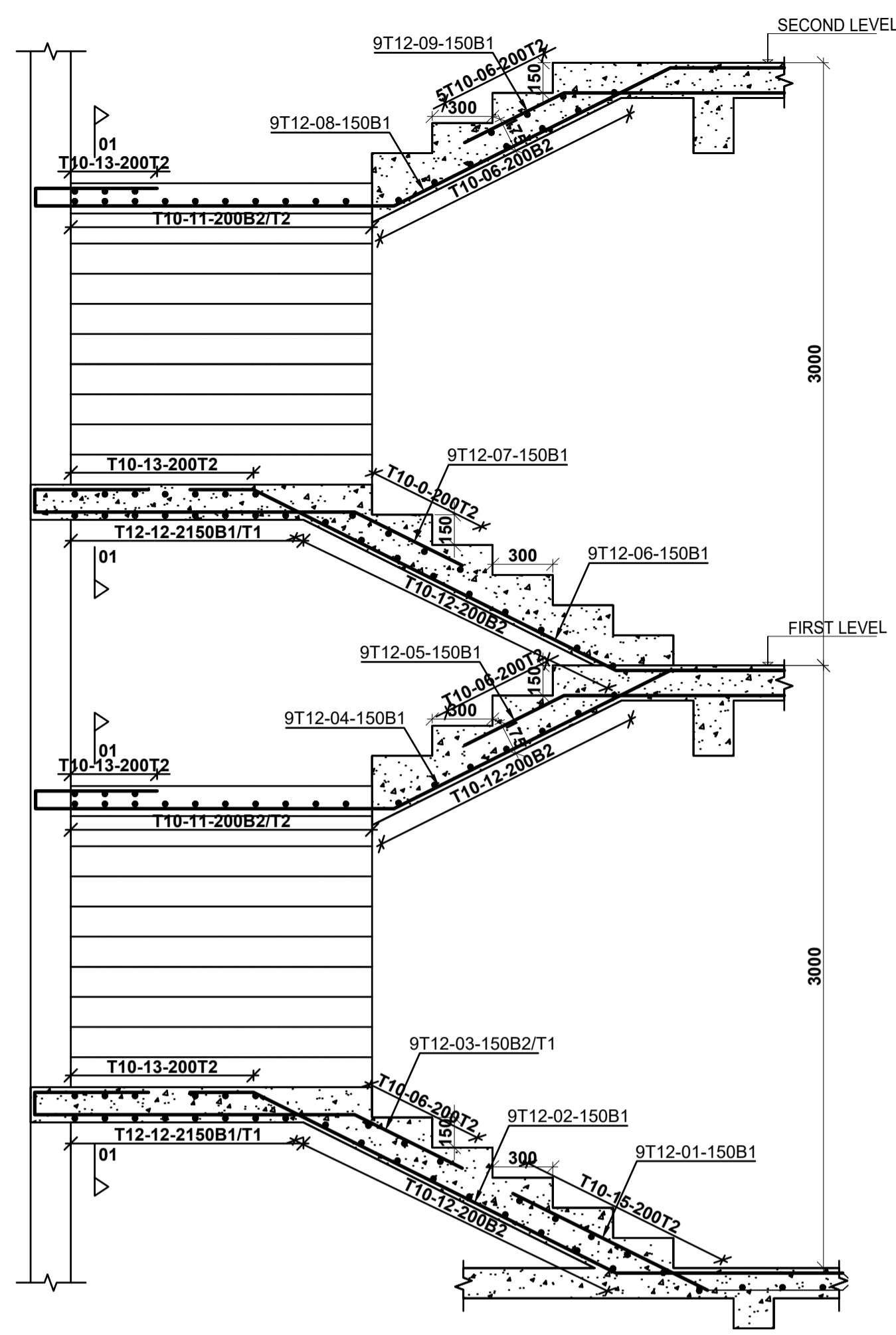
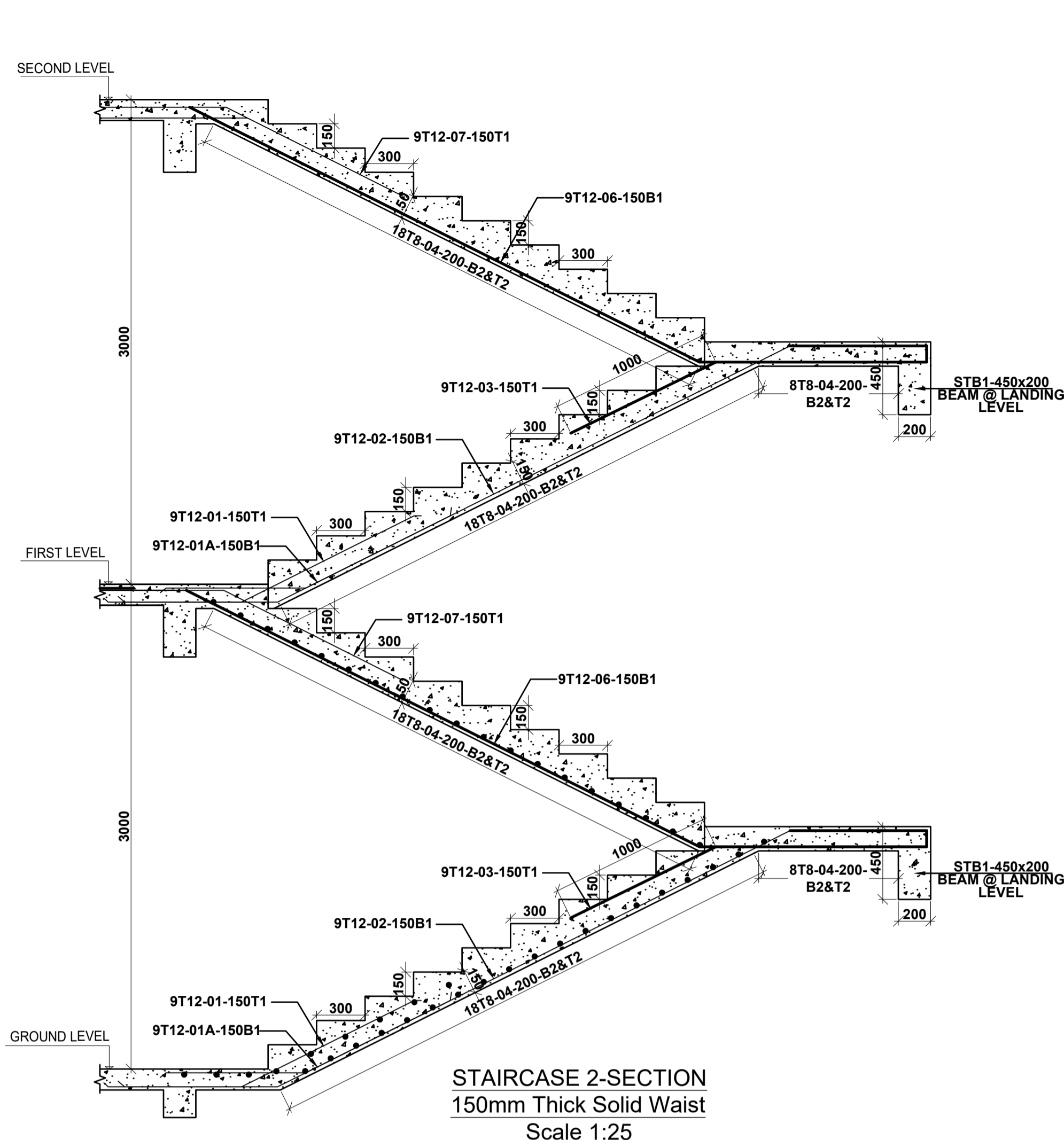

**NOTES**  
 1. All dimensions are in millimetres unless otherwise stated.  
 2. All reinforcements must be checked and approved by project structural engineer prior to concreting.  
 3. All reinforced concrete to be Class 25 mix and blinding concrete to be Class 15 mix.  
 4. Only figured dimensions to be taken from this drawing.  
 5. Any discrepancy in dimensions to be reported to the project consultants i.e architect or engineer.

6. Symbols: T-TMT Rebars to BS 4461: T - Top face  
B - Bottom face  
 7. Cover to reinforcement; Slabs - 20mm, Beams - 25mm, Columns - 40mm, Foundations - 50mm  
 8. All structural steel be grade 43A.  
 9. All welds are 6mm thick.  
 10. All structural steel to be painted with anti-rust primer paint.

**Client**  
 MINISTRY OF LANDS, PUBLIC WORKS,  
 HOUSING AND URBAN DEVELOPMENT  
 STATE DEPARTMENT FOR HOUSING AND URBAN  
 DEVELOPMENT

**STRUCTURAL ENGINEER:**

Designed by: H.I.H      Checked by: R.M.O  
 Approved by: SECRETARY, HOUSING DEPARTMENT  
 Date: 17TH APRIL 2024      Scale: As shown  
 Drawing Number: AHP-G+9-BLKA 17

**Project**  
 PROPOSED AFFORDABLE HOUSING  
 PROGRAM-G+9 GENERIC BLOCK A.  
**Title**  
 TYPICAL FLOOR LAYOUTS

Revisions		
No.	Description	Date

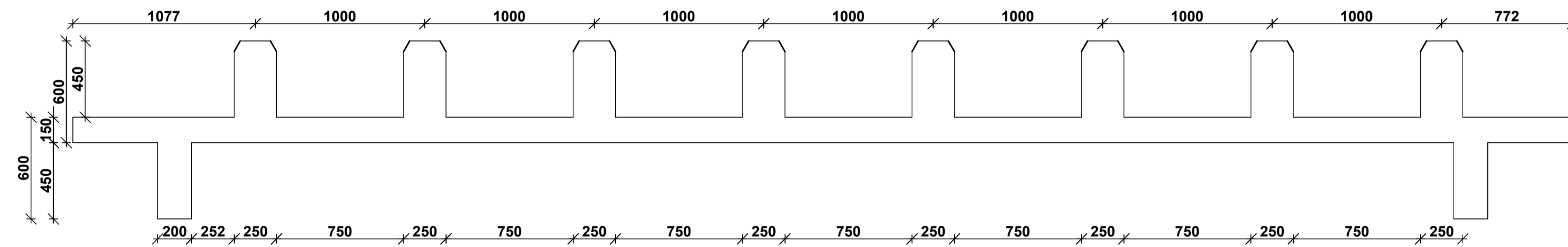

**WATER TANK BEARER BEAMS**  
SECTION 130mm SOLID SLAB  
SCALE 1:25

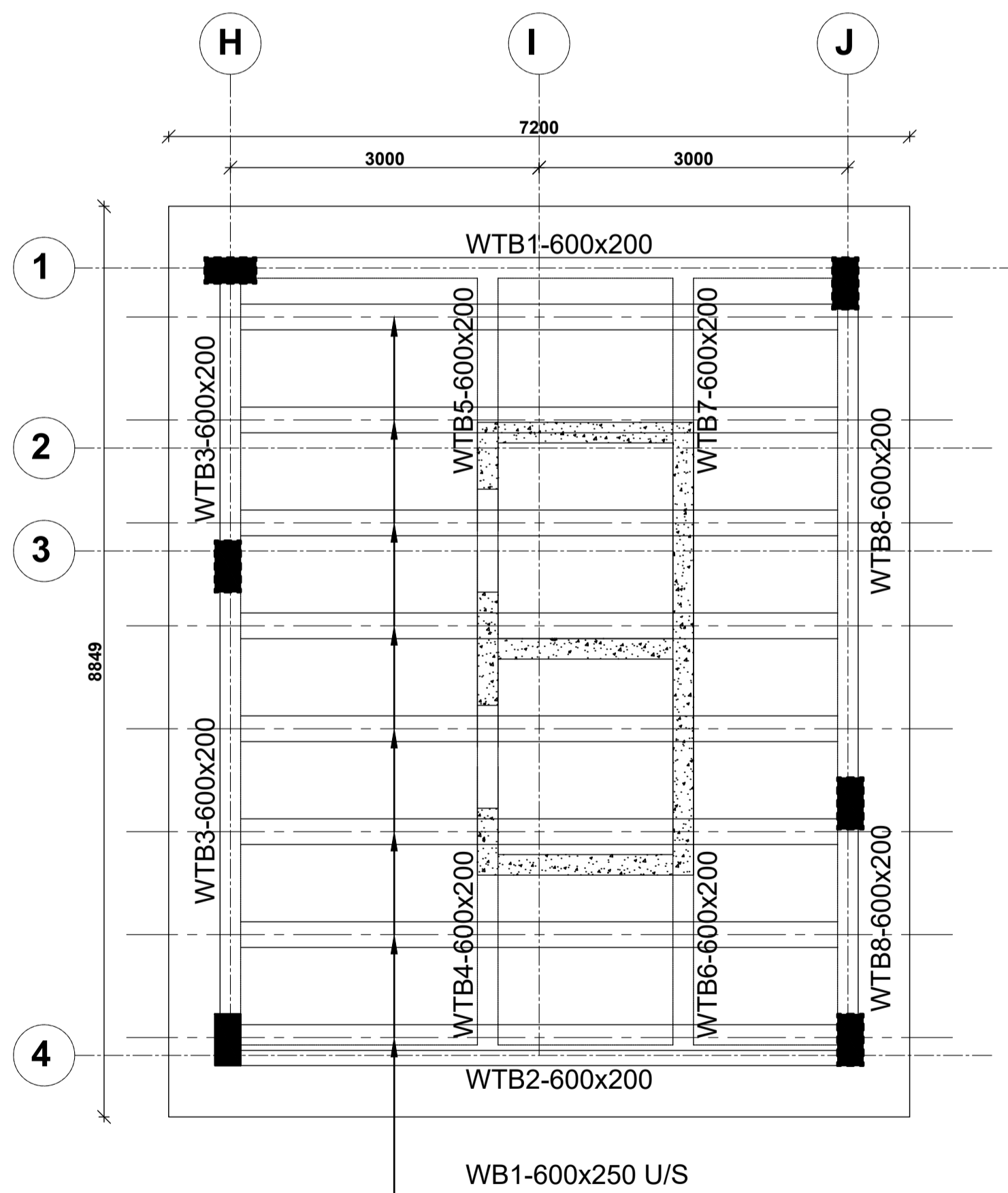
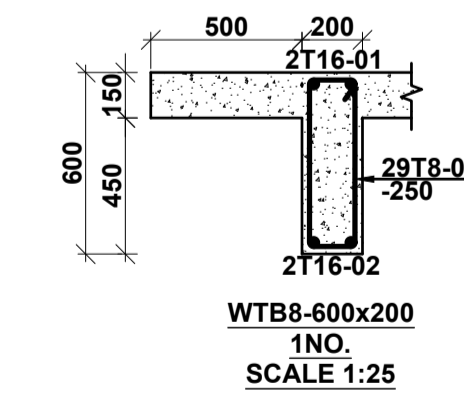
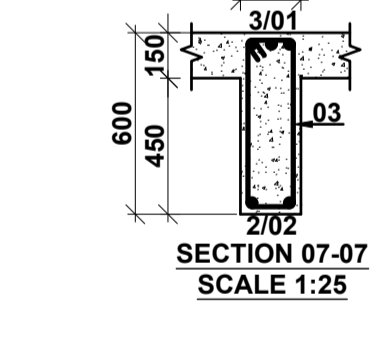
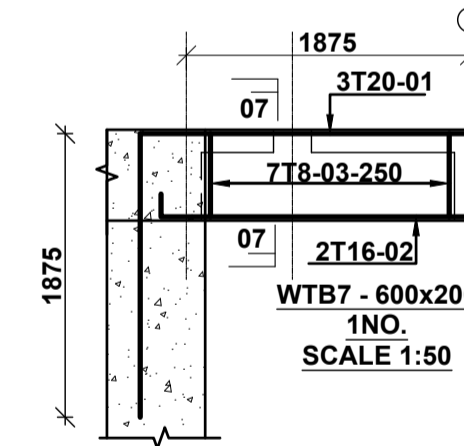
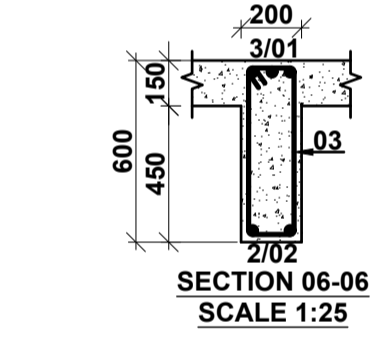
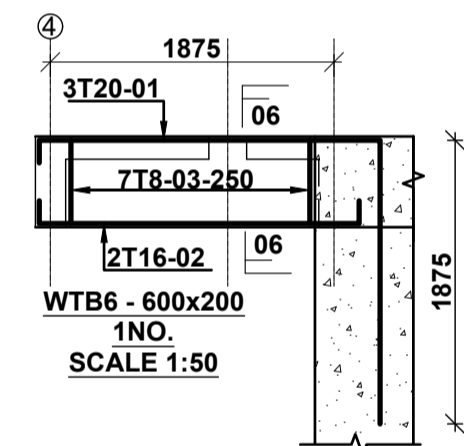
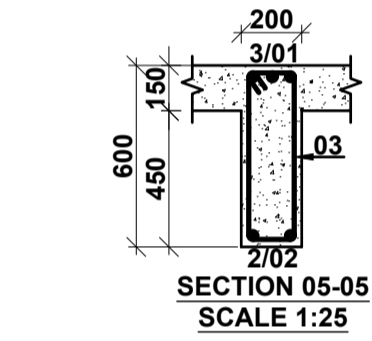
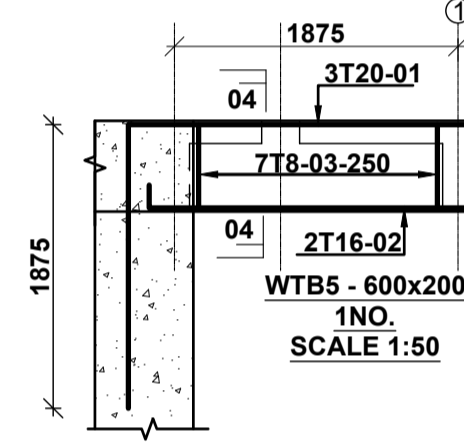
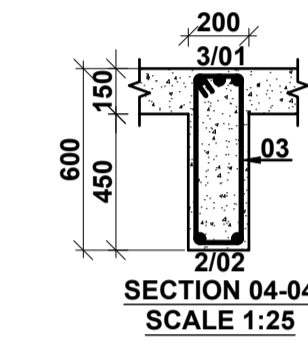
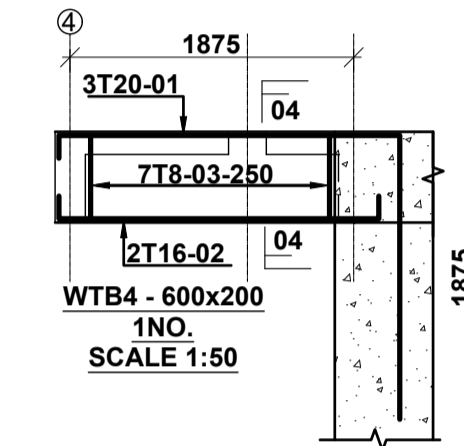
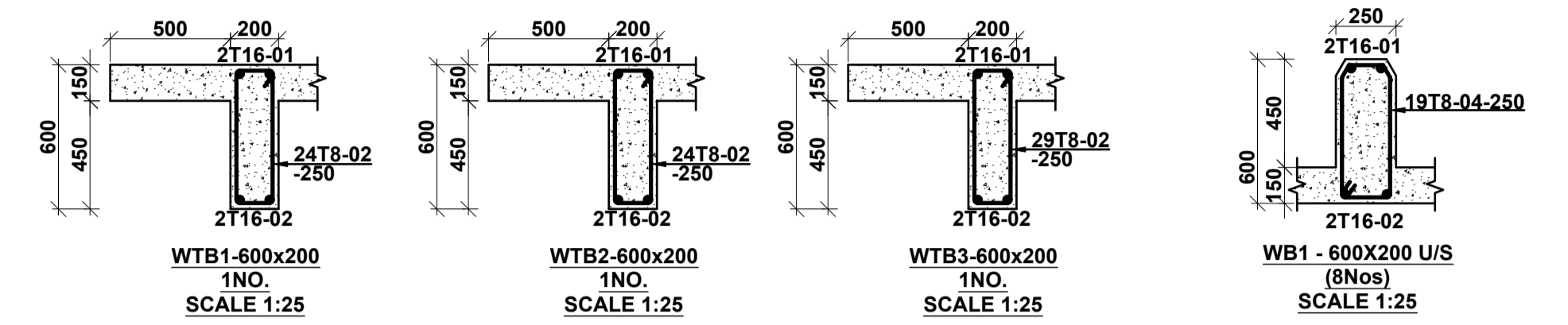

**WATER TANK LAYOUT**  
150mm THICK SOLID SLAB  
SCALE 1:50

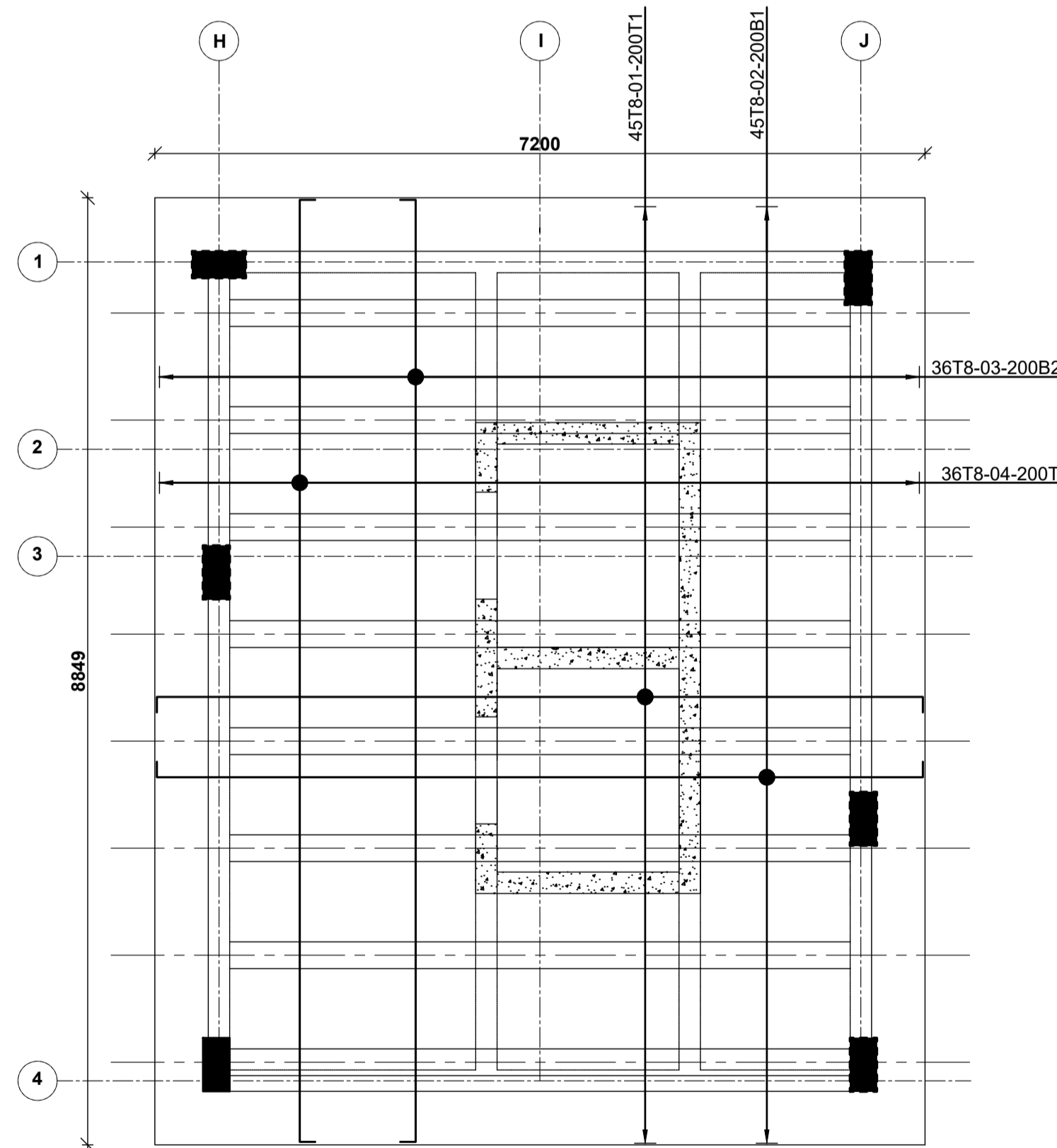

**WATER TANK SLAB DETAILS**  
150mm THICK SOLID SLAB  
SCALE 1:50

**NOTE:**  
1. Foundations to be excavated to a minimum depth of 3.5m  
2. Introduce a 300x200 ground beam over all the foundation wallings  
3. All masonry units to be machine cut blocks

**NOTES**  
1. All dimensions are in millimetres unless otherwise stated.  
2. All reinforcements must be checked and approved by project structural engineer prior to concreting.  
3. All reinforced concrete to be Class 25 mix and blinding concrete to be Class 15 mix.  
4. Only figured dimensions to be taken from this drawing.  
5. Any discrepancy in dimensions to be reported to the project consultants i.e architect or engineer.

6. Symbols: T-TMT Rebars to BS 4461: T - Top face  
B - Bottom face  
7. Cover to reinforcement; Slabs - 20mm, Beams - 25mm, Columns - 40mm, Foundations - 50mm  
8. All structural steel be grade 43A.  
9. All welds are 6mm thick.  
10. All structural steel to be painted with anti-rust primer paint.

**Client**  
MINISTRY OF LANDS, PUBLIC WORKS,  
HOUSING AND URBAN DEVELOPMENT  
STATE DEPARTMENT FOR HOUSING AND URBAN  
DEVELOPMENT

**STRUCTURAL ENGINEER:**

Designed by: H.I.H Checked by: R.M.O  
Approved by: SECRETARY, HOUSING DEPARTMENT  
Date: 18TH APRIL 2024 Scale: As shown  
Drawing Number: AHP-G+9-BLKA 18

**Project**  
PROPOSED AFFORDABLE HOUSING  
PROGRAM-G+9 GENERIC BLOCK A.  
**Title**  
WATER TANK DETAILS.

Revisions		
No.	Description	Date



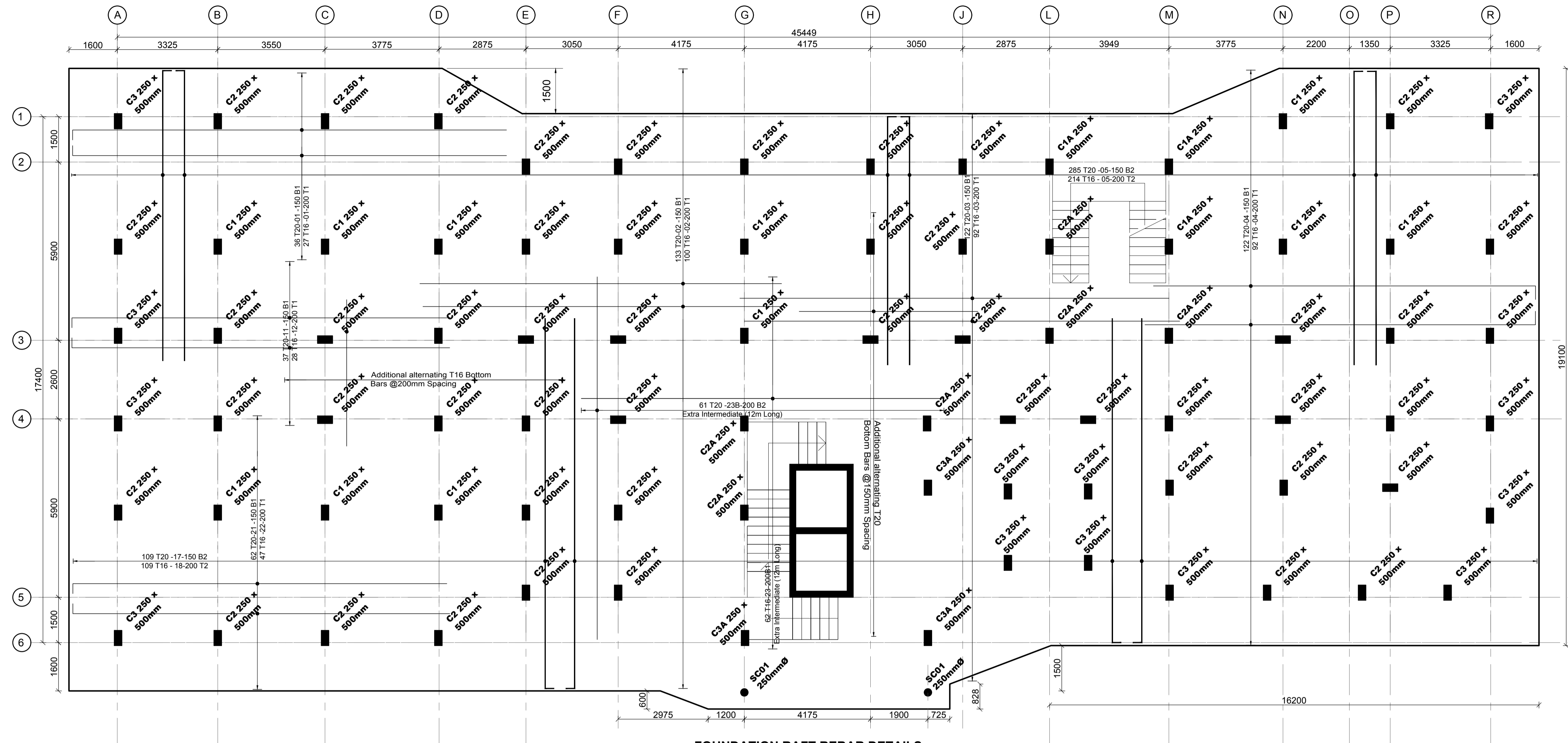

**FOUNDATION RAFT REBAR DETAILS**  
**750 MM THK RAFT SLAB**  
**SCALE 1:75**

**NOTE: RAFT FORMATION SURFACE TO BE COMPACTED PRIOR TO LAYING OF RAFT BLINDING**

ELEMENT	Kg/m3
FOUNDATION	36
COLUMNS	193
SLAB	66
BEAMS	62
GROUND BEAMS	103
STAIRCASE 1	166
STAIRCASE 2	121
LIFT	88
SLAB OVER STAIRCASE 1	112
BEAM OVER STAIRCASE 1	95
SLAB OVER STAIRCASE 2	122
BEAMS OVER STAIRCASE 2	108

**NOTES**

- All dimensions are in millimetres unless otherwise stated.
- All reinforcements must be checked and approved by project structural engineer prior to concreting.
- All reinforced concrete to be Class 25 mix and blinding concrete to be Class 15 mix.
- Only figured dimensions to be taken from this drawing.
- Any discrepancy in dimensions to be reported to the project consultants i.e architect or engineer.

- Symbols; T-TMT Rebars to B S 4 461 : T - Top face  
B - Bottom face
- Cover to reinforcement; Slabs - 20mm,  
Beams - 25mm, Columns - 40mm, Foundations - 50mm
- All structural steel be grade 43A.
- All welds are 6mm thick.
- All structural steel to be painted with anti-rust primer paint.

Client  
**MINISTRY OF LANDS, PUBLIC WORKS,  
HOUSING AND URBAN DEVELOPMENT**  
STATE DEPARTMENT FOR HOUSING AND URBAN  
DEVELOPMENT

STRUCTURAL ENGINEER:

Designed by: *JMN* Checked by: *JMN*  
Approved by: SECRETARY, HOUSING DEPARTMENT  
Date: 13th March 2024 Scale: As shown  
Drawing Number: AHP-G+9-BLKB 1.0B

Project **PROPOSED AFFORDABLE  
HOUSING DEVELOPMENT  
(BLOCK TYPE B MARKET UNITS)**  
Title **FOUNDATION RAFT RC DETAILS**

Revisions		
No.	Description	Date

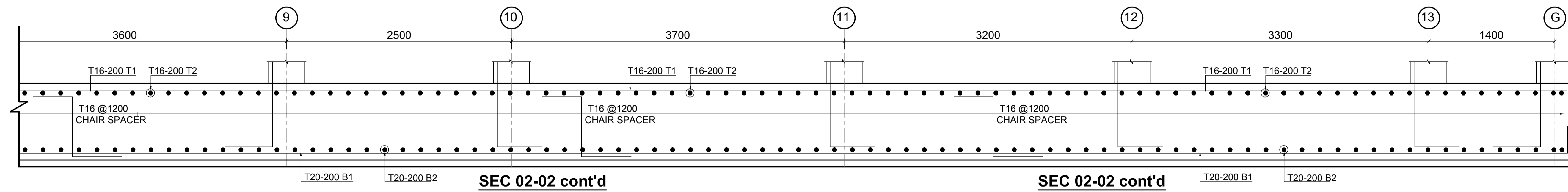
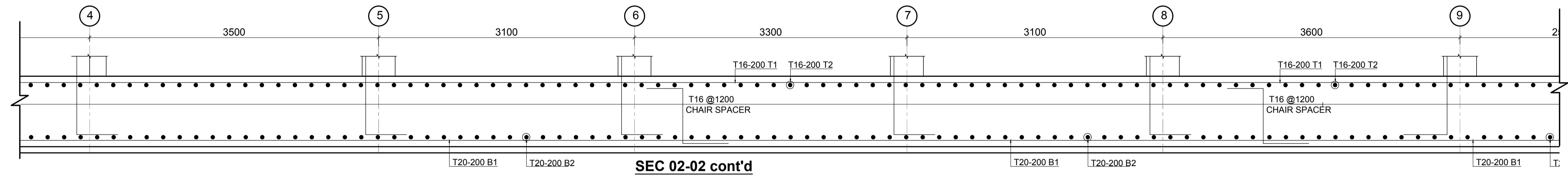
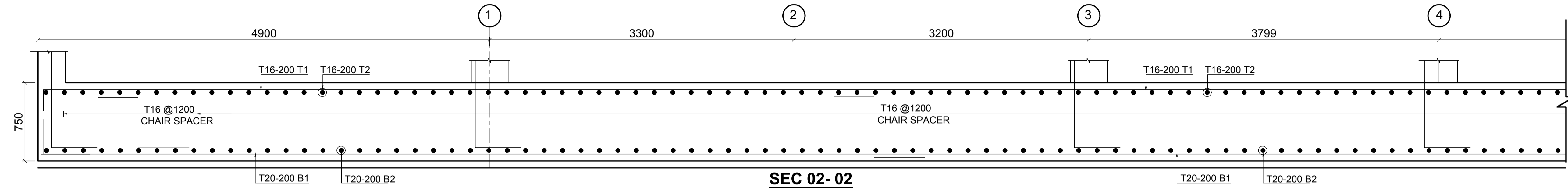
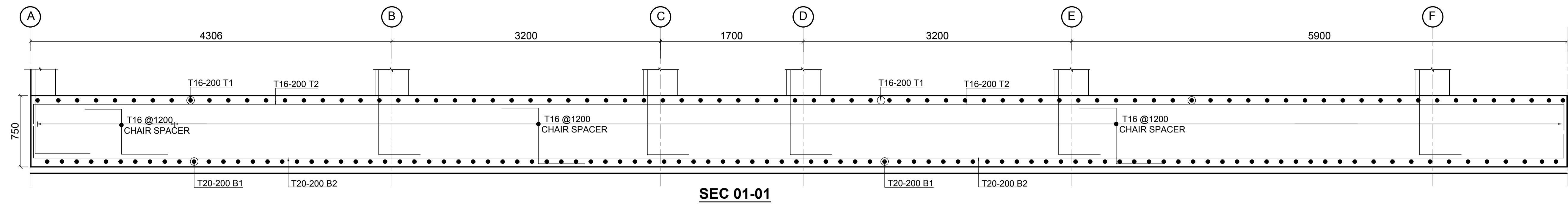

**NOTES**  
 1. All dimensions are in millimetres unless otherwise stated.  
 2. All reinforcements must be checked and approved by project structural engineer prior to concreting.  
 3. All reinforced concrete to be Class 25 mix and blinding concrete to be Class 15 mix.  
 4. Only figured dimensions to be taken from this drawing.  
 5. Any discrepancy in dimensions to be reported to the project consultants i.e architect or engineer.

6. Symbols; T-TMT Rebars to B S 4 461 : T - Top face  
 B - Bottom face  
 7. Cover to reinforcement; Slabs - 20mm,  
 Beams - 25mm, Columns - 40mm, Foundations - 50mm  
 8. All structural steel be grade 43A.  
 9. All welds are 6mm thick.  
 10. All structural steel to be painted with anti-rust primer paint.

Client  
**MINISTRY OF LANDS, PUBLIC WORKS,  
 HOUSING AND URBAN DEVELOPMENT**  
 STATE DEPARTMENT FOR HOUSING AND URBAN  
 DEVELOPMENT

STRUCTURAL ENGINEER:

Designed by: *JMN*      Checked by: JMN  
 Approved by: SECRETARY, HOUSING DEPARTMENT  
 Date: 13th March 2024      Scale: As shown  
 Drawing Number: *AHP-G+9-BLKB 1.1B*

Project **PROPOSED AFFORDABLE  
 HOUSING DEVELOPMENT  
 (BLOCK TYPE B MARKET UNITS)**  
 Title **RAFT SECTION RC DETAILS**

Revisions		
No.	Description	Date

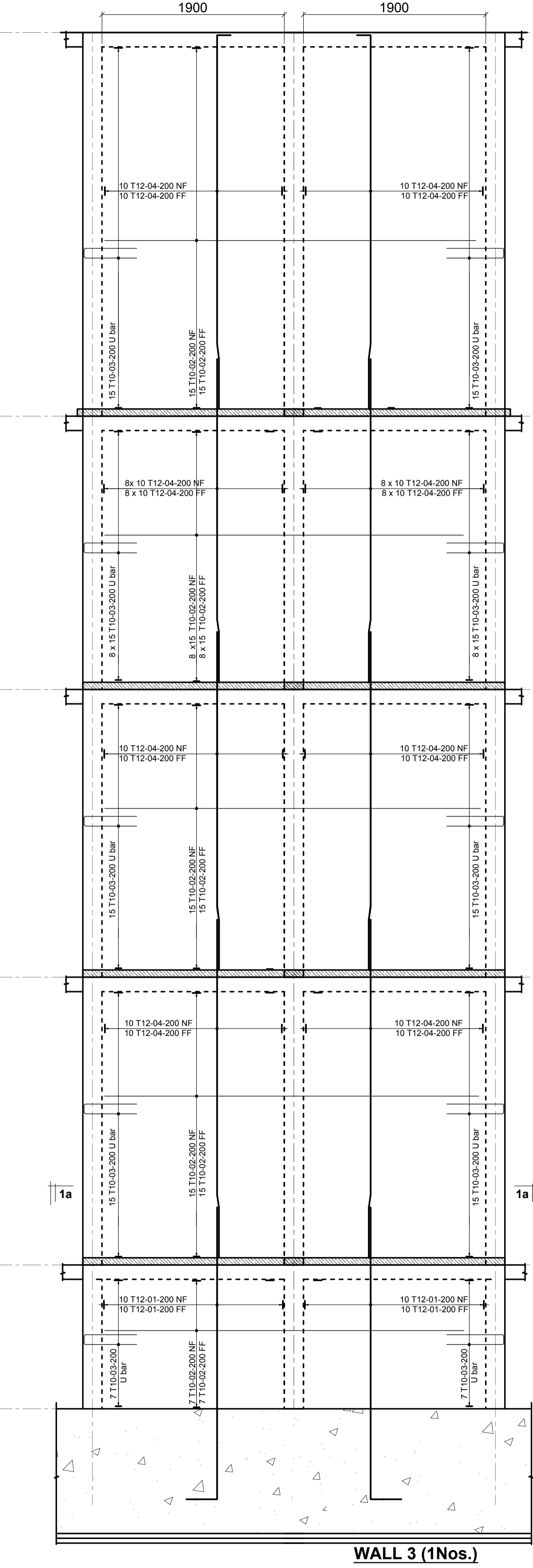
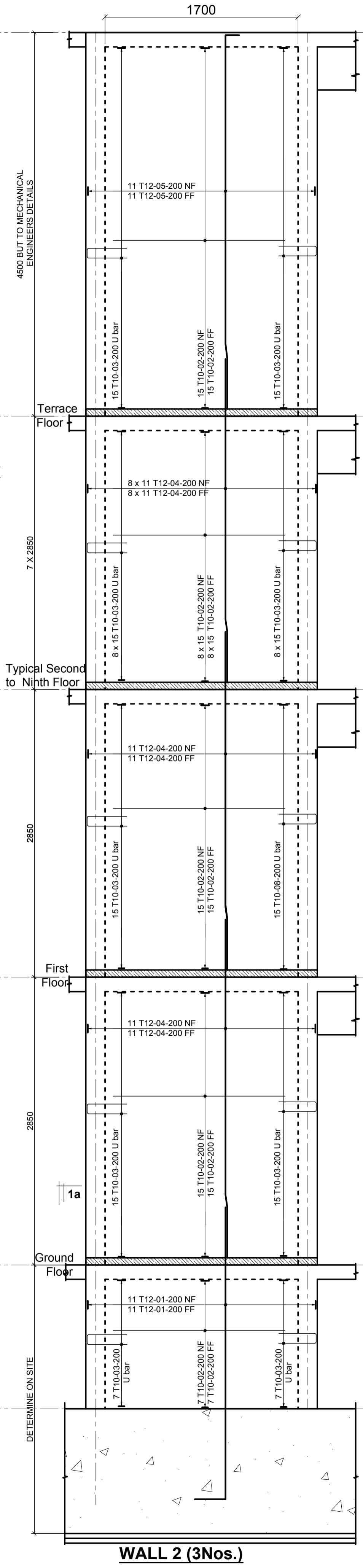
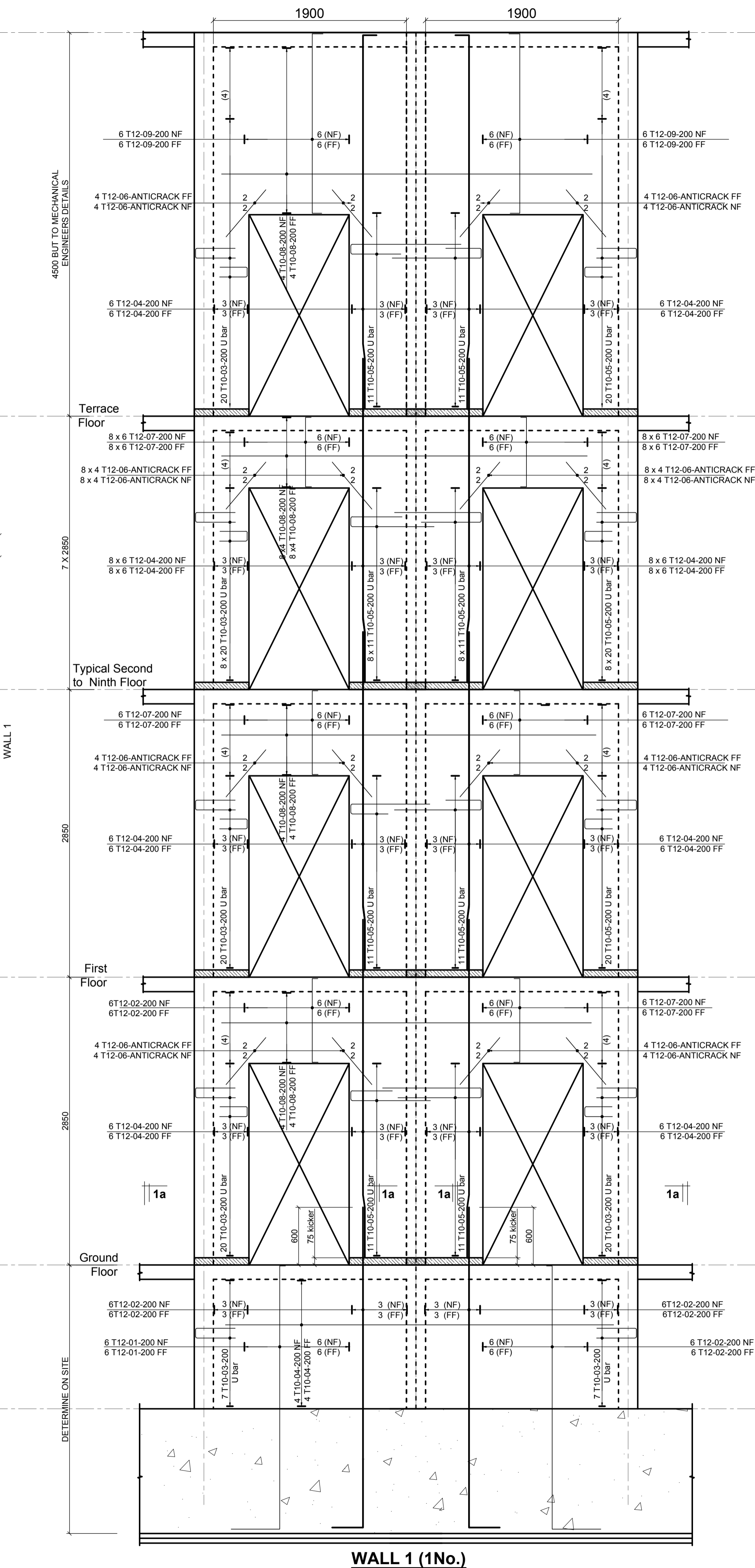
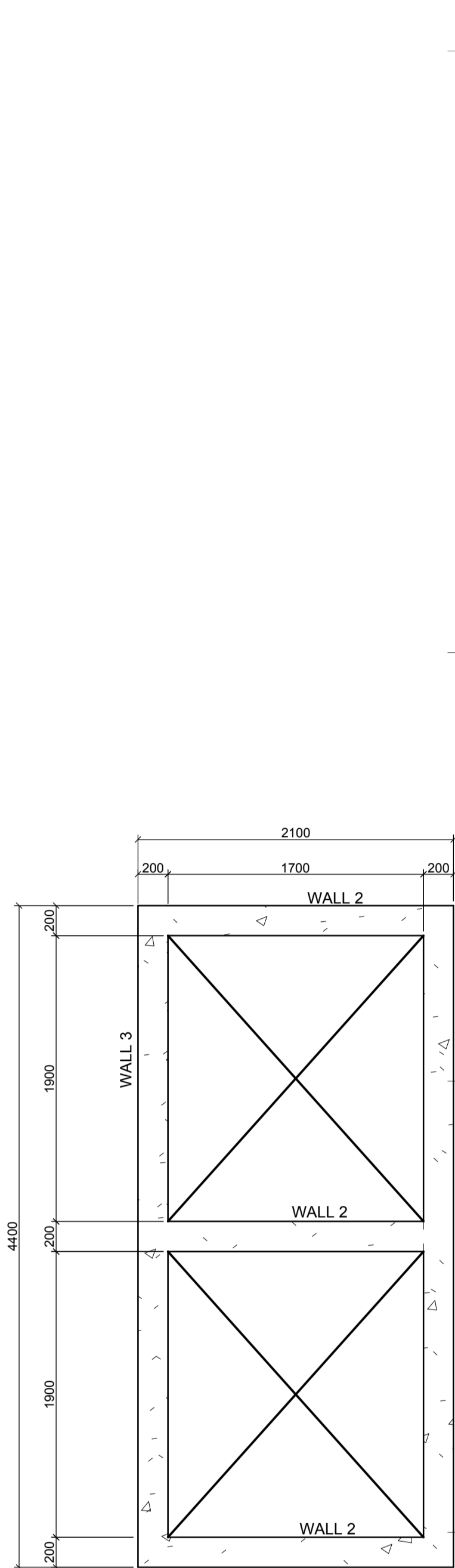

4500 BUT TO MECHANICAL ENGINEERS DETAILS

4500 BUT TO MECHANICAL ENGINEERS DETAILS

Terrace

Terrace

Floor

Floor

Typical Second to Ninth Floor

Typical Second to Ninth Floor

First Floor

First Floor

Ground Floor

Ground Floor

DETERMINE ON SITE

DETERMINE ON SITE

Project		Revisions	
PROPOSED AFFORDABLE HOUSING DEVELOPMENT (BLOCK TYPE B MARKET UNITS)		No.	Description
Title		Date	
LIFT SHAFT RC DETAILS			
Designed by: JMN	Checked by: JMN	Approved by: SECRETARY, HOUSING DEPARTMENT	
Date: 13th March 2024	Scale: As shown	Drawing Number: AMP-C-9-B/LAB 2.0B	
Client: MINISTRY OF LANDS, PUBLIC WORKS, HOUSING AND URBAN DEVELOPMENT			
STATE DEPARTMENT FOR HOUSING AND URBAN DEVELOPMENT			
NOTES: 1. All dimensions are in millimetres unless otherwise stated. 2. All reinforcements must be checked and approved by project structural engineer prior to concreting. 3. All reinforcement to be Class 25, mix and blending concrete to be Class 15 mix. 4. Only figured dimensions to be taken from this drawing. 5. Any discrepancy in dimensions to be reported to the project consultants i.e architect or engineer. 6. Symbols: T-TMT Rebars to B S 4 461 T - Top face, B - Bottom face 7. Cover to reinforcement: Slabs - 20mm, Beams - 25mm, Columns - 40mm, Foundations - 50mm 8. All structural steel to be grade 43A. 9. All structural steel to be painted with anti-rust primer paint.			

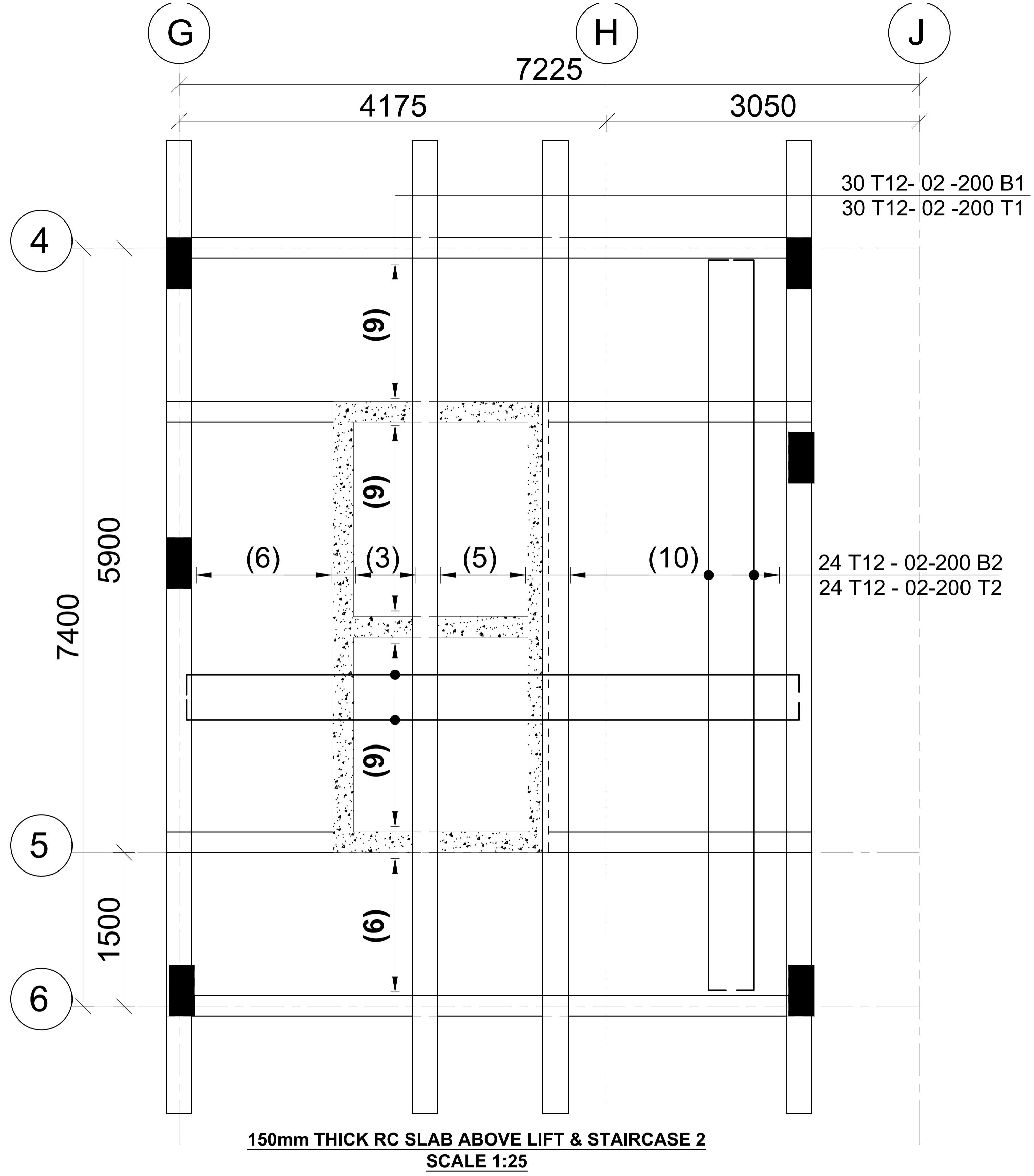
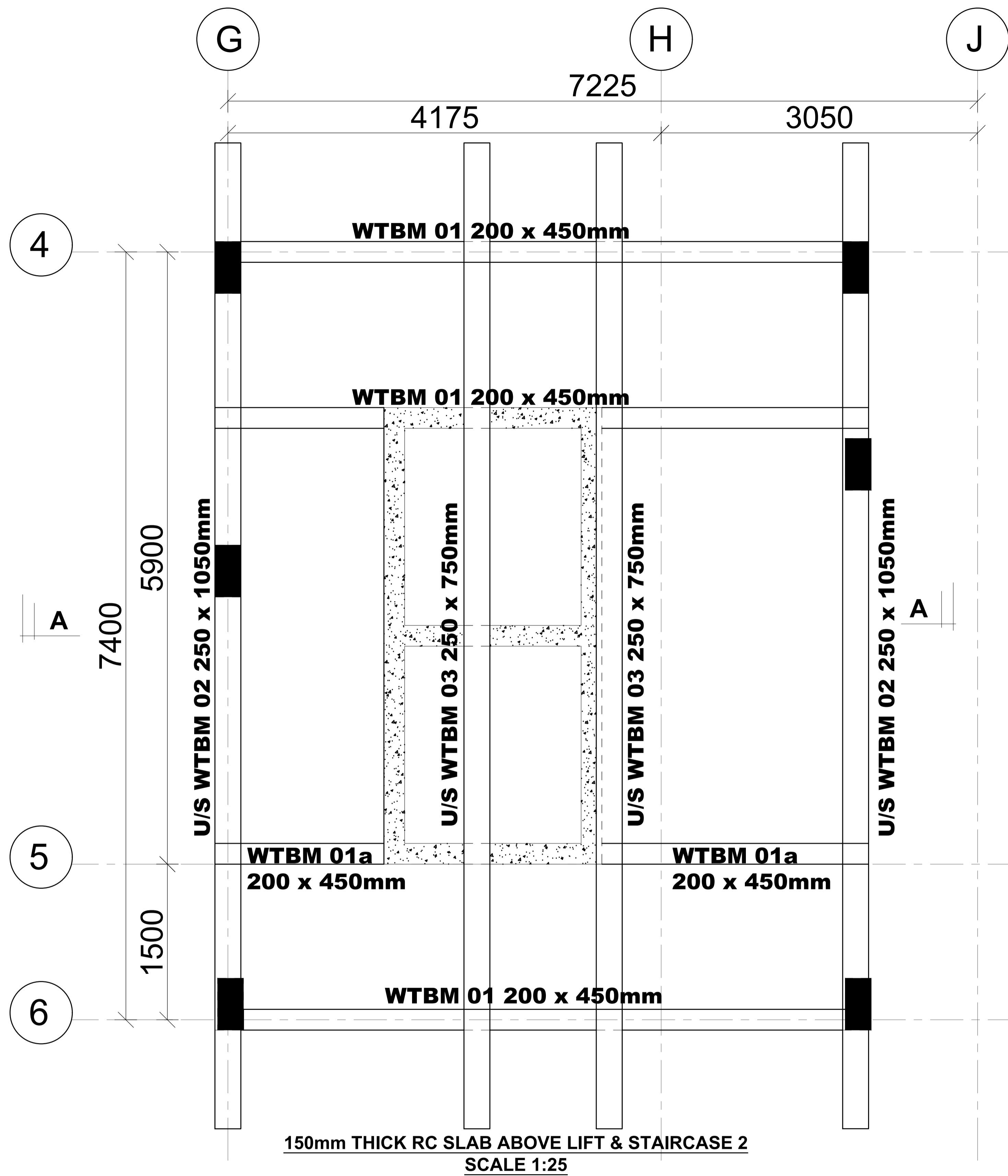

**NOTES**  
 1. All dimensions are in millimetres unless otherwise stated.  
 2. All reinforcements must be checked and approved by project structural engineer prior to concreting.  
 3. All reinforced concrete to be Class 25 mix and blinding concrete to be Class 15 mix.  
 4. Only figured dimensions to be taken from this drawing.  
 5. Any discrepancy in dimensions to be reported to the project consultants i.e architect or engineer.

6. Symbols; T-TMT Rebars to B S 4 461 : T - Top face  
 B - Bottom face  
 7. Cover to reinforcement; Slabs - 20mm,  
 Beams - 25mm, Columns - 40mm, Foundations - 50mm  
 8. All structural steel be grade 43A.  
 9. All welds are 6mm thick.  
 10. All structural steel to be painted with anti-rust primer paint.

Client  
**MINISTRY OF LANDS, PUBLIC WORKS,  
 HOUSING AND URBAN DEVELOPMENT**  
 STATE DEPARTMENT FOR HOUSING AND URBAN  
 DEVELOPMENT

STRUCTURAL ENGINEER:

Designed by: *JMN* Checked by: *JMN*  
 Approved by: SECRETARY, HOUSING DEPARTMENT  
 Date: 13th March 2024 Scale: As shown  
 Drawing Number: *AHP-G+9-BLKB 2.1B*

Project **PROPOSED AFFORDABLE  
 HOUSING DEVELOPMENT  
 (BLOCK TYPE B MARKET UNITS)**  
 Title **SLAB OVER LIFT SHAFT RC DETAILS**

Revisions		
No.	Description	Date

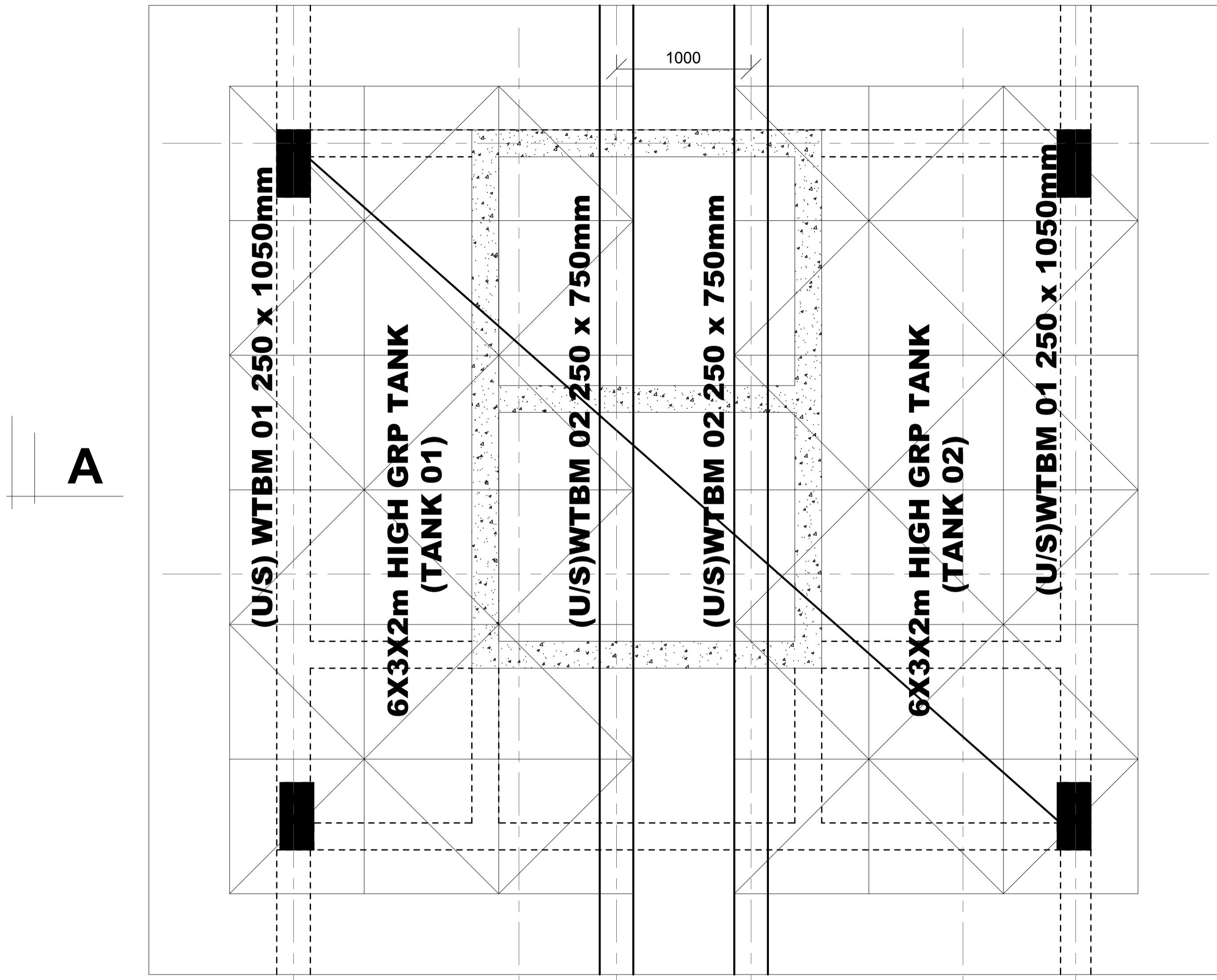

**SLAB LAYOUT ABOVE LIFT & GRP RC BEARER BEAMS**  
SCALE 1:25

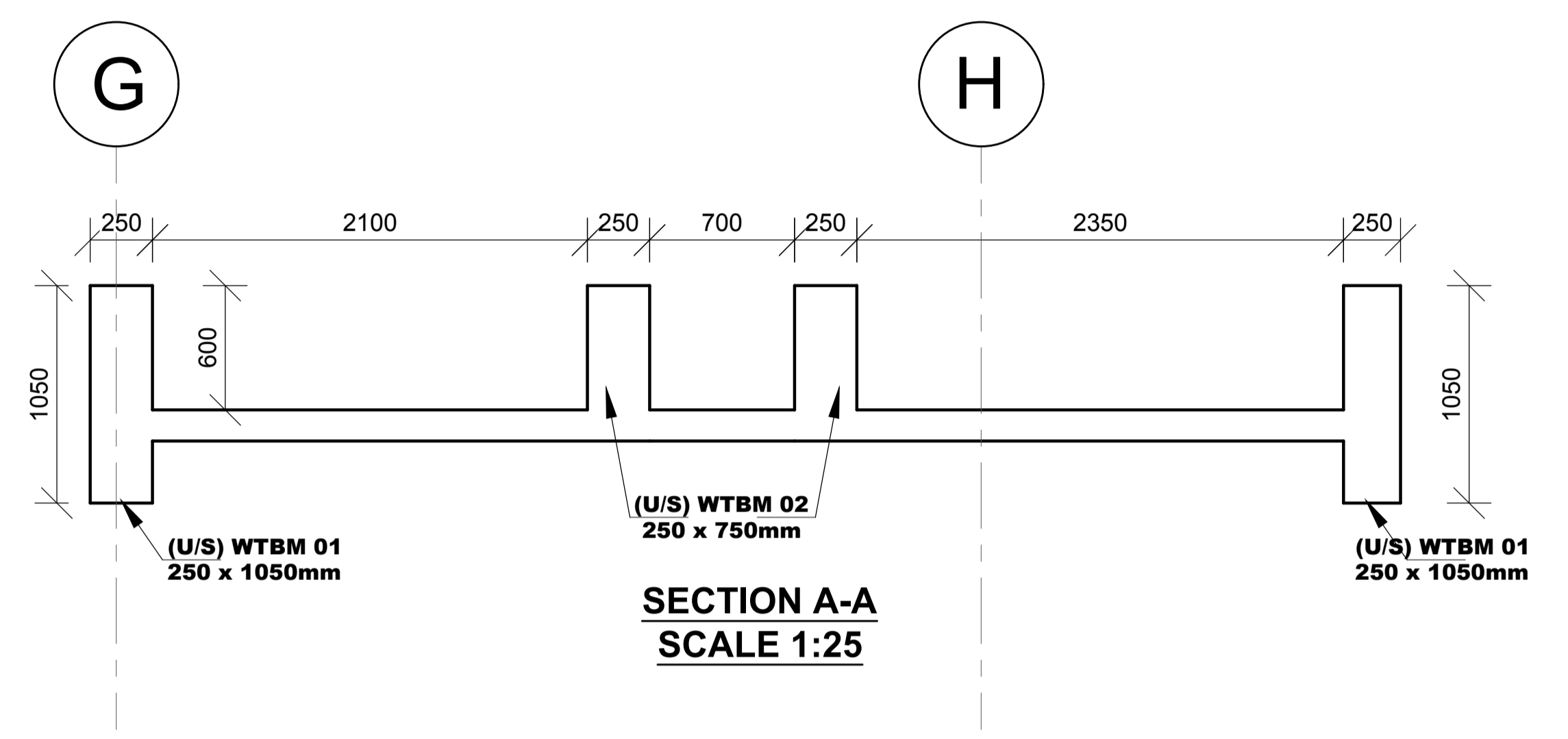

**SECTION A-A**  
SCALE 1:25

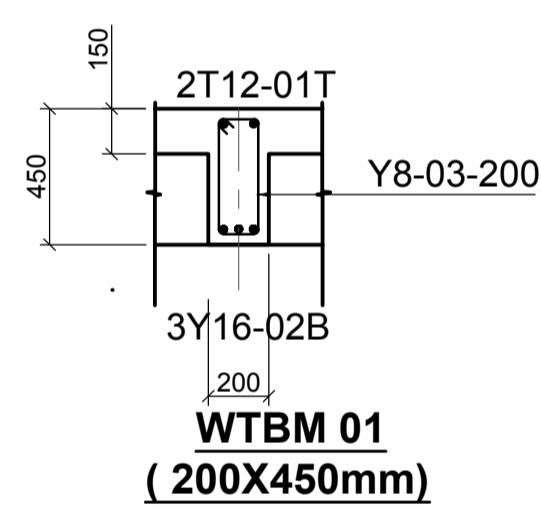

**WTBM 01**  
(200X450mm)

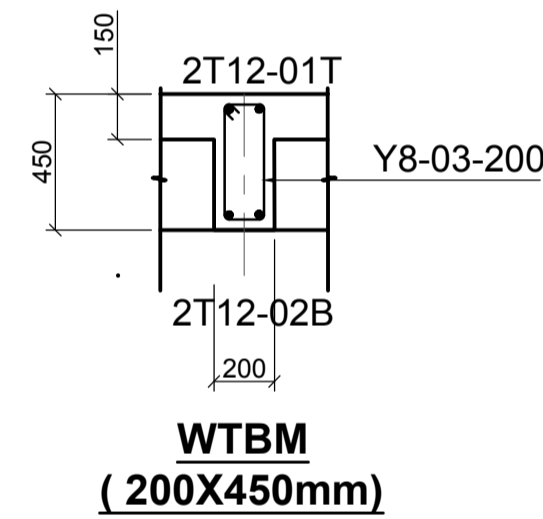

**WTBM**  
(200X450mm)

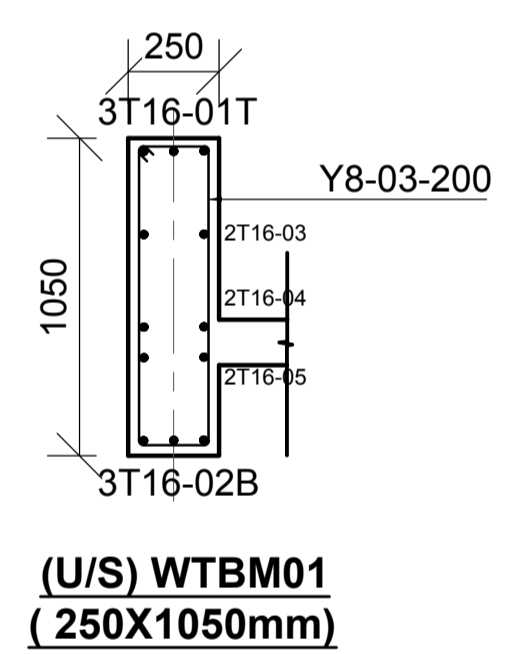

**(U/S) WTBM01**  
(250X1050mm)

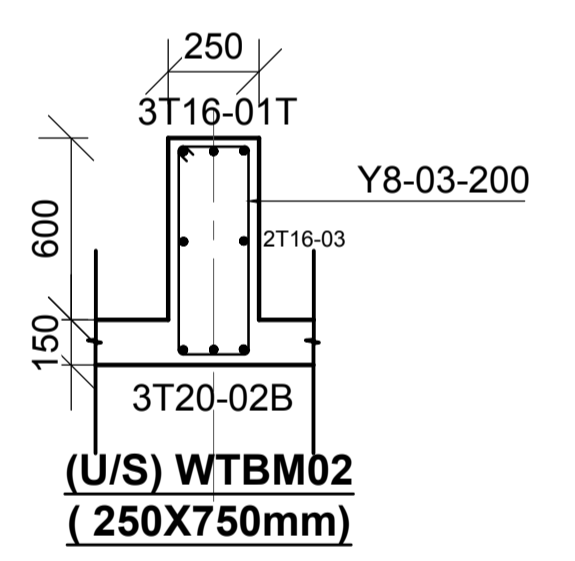

**(U/S) WTBM02**  
(250X750mm)

**NOTES**  
 1. All dimensions are in millimetres unless otherwise stated.  
 2. All reinforcements must be checked and approved by project structural engineer prior to concreting.  
 3. All reinforced concrete to be Class 25 mix and blinding concrete to be Class 15 mix.  
 4. Only figured dimensions to be taken from this drawing.  
 5. Any discrepancy in dimensions to be reported to the project consultants i.e architect or engineer.

6. Symbols; T-TMT Rebars to B S 4 461 : T - Top face  
 B - Bottom face  
 7. Cover to reinforcement; Slabs - 20mm,  
 Beams - 25mm, Columns - 40mm, Foundations - 50mm  
 8. All structural steel be grade 43A.  
 9. All welds are 6mm thick.  
 10. All structural steel to be painted with anti-rust primer paint.

Client  
**MINISTRY OF LANDS, PUBLIC WORKS,  
 HOUSING AND URBAN DEVELOPMENT**  
 STATE DEPARTMENT FOR HOUSING AND URBAN  
 DEVELOPMENT

STRUCTURAL ENGINEER:

Designed by: JMN Checked by: JMN  
 Approved by: SECRETARY, HOUSING DEPARTMENT  
 Date: 13th March 2024 Scale: As shown  
 Drawing Number: AHP-G+9-BLKB 2.2B

Project **PROPOSED AFFORDABLE  
 HOUSING DEVELOPMENT  
 (BLOCK TYPE B MARKET UNITS)**  
 Title **SLAB OVER LIFT SHAFT RC DETAILS**

Revisions		
No.	Description	Date

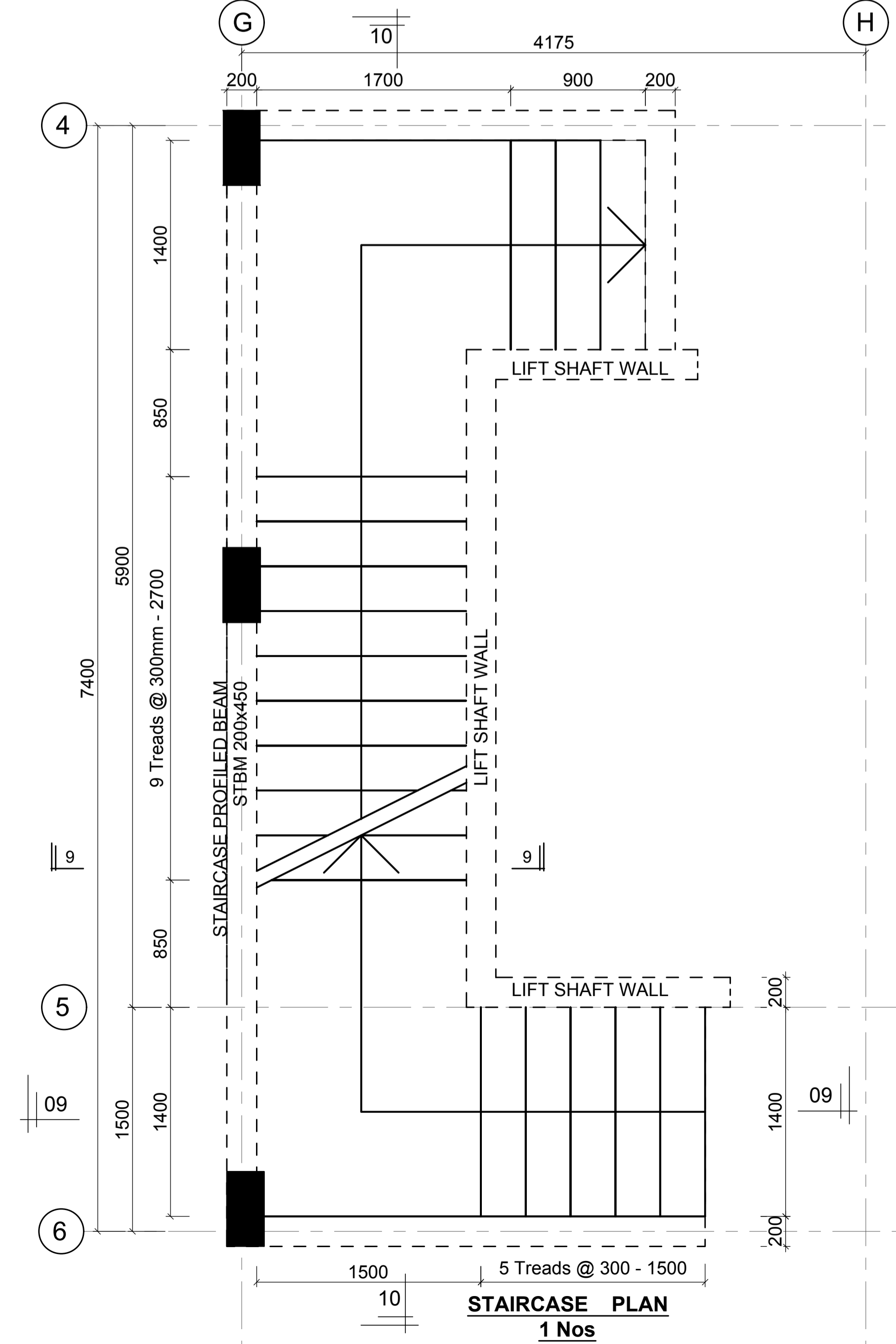
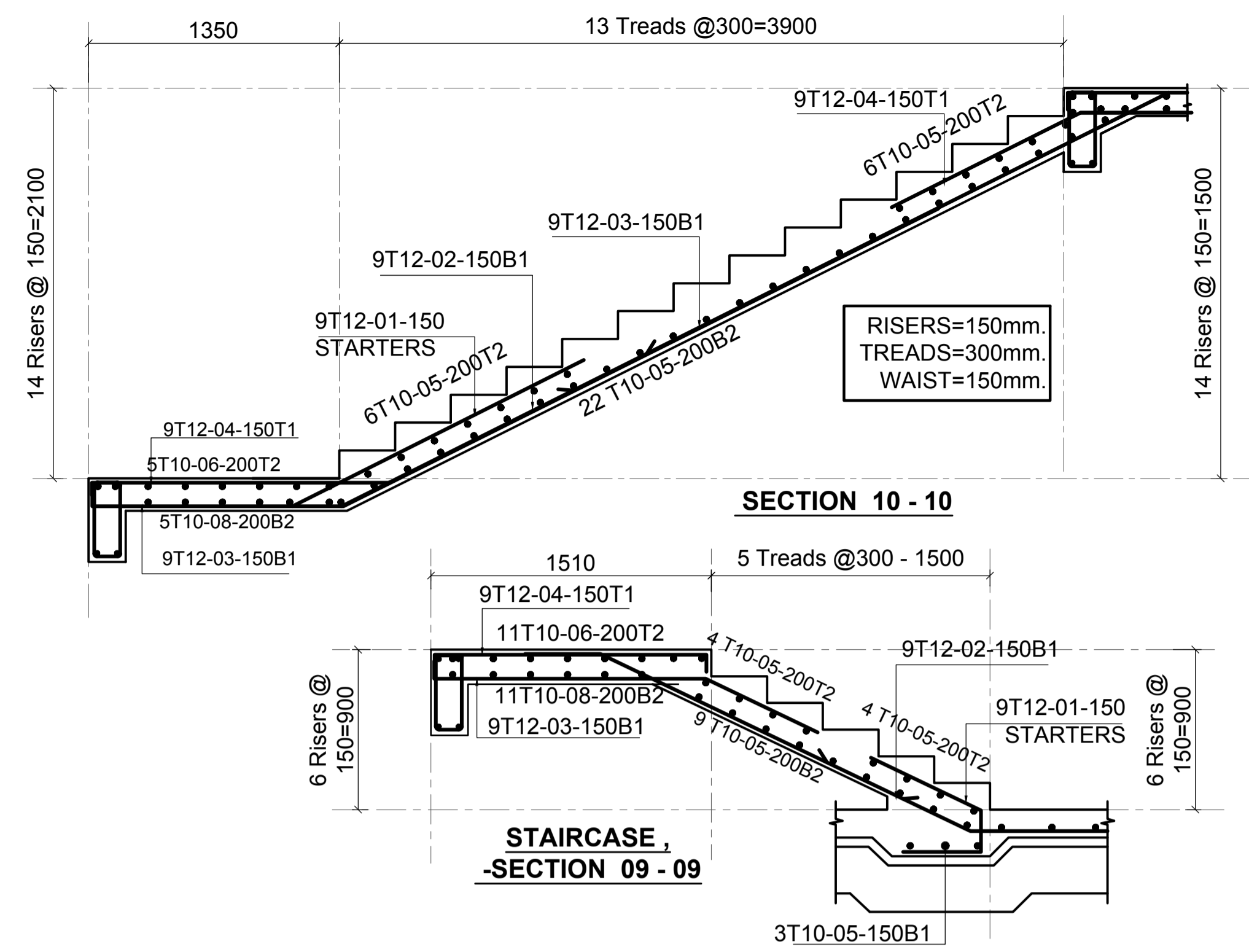
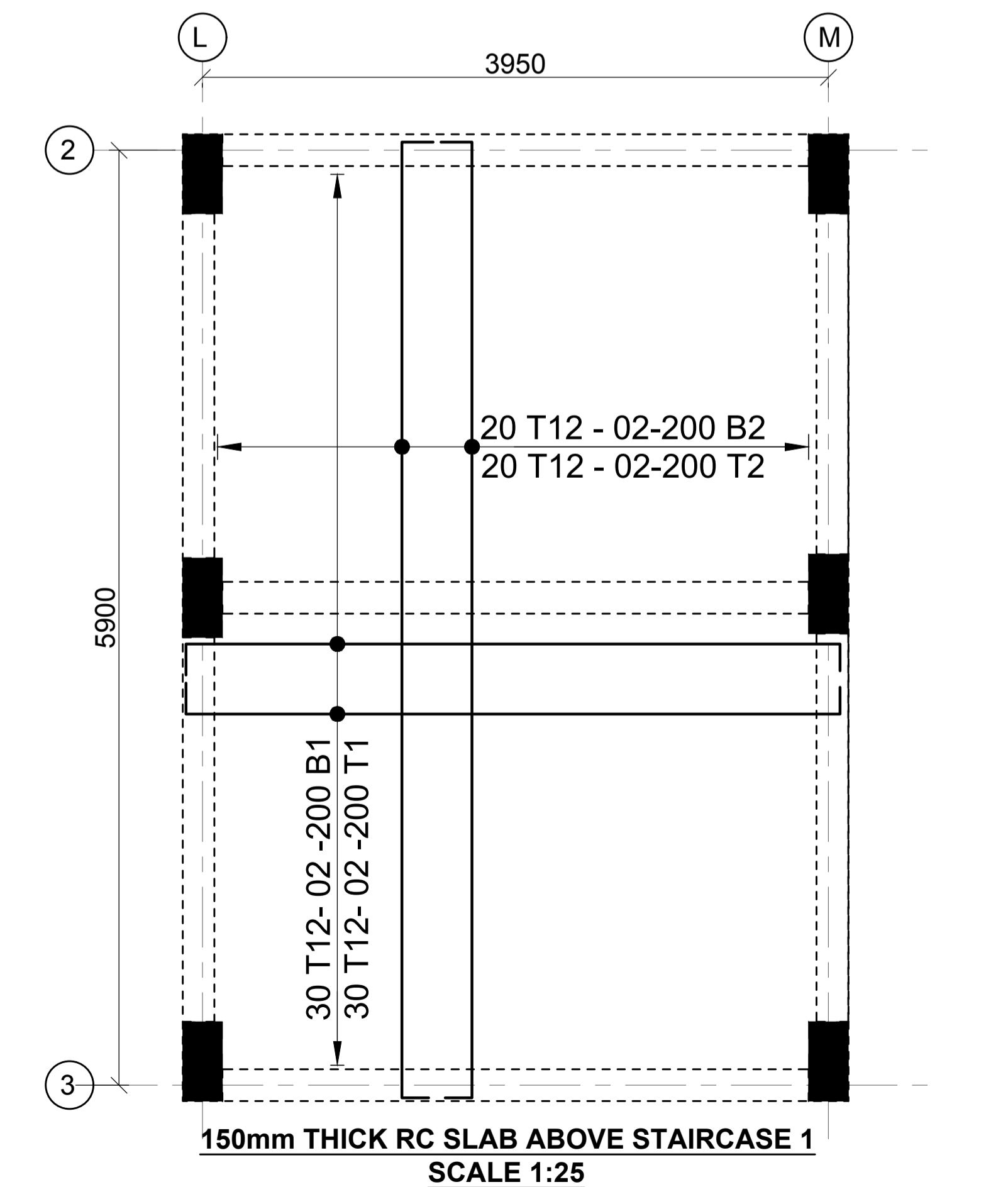
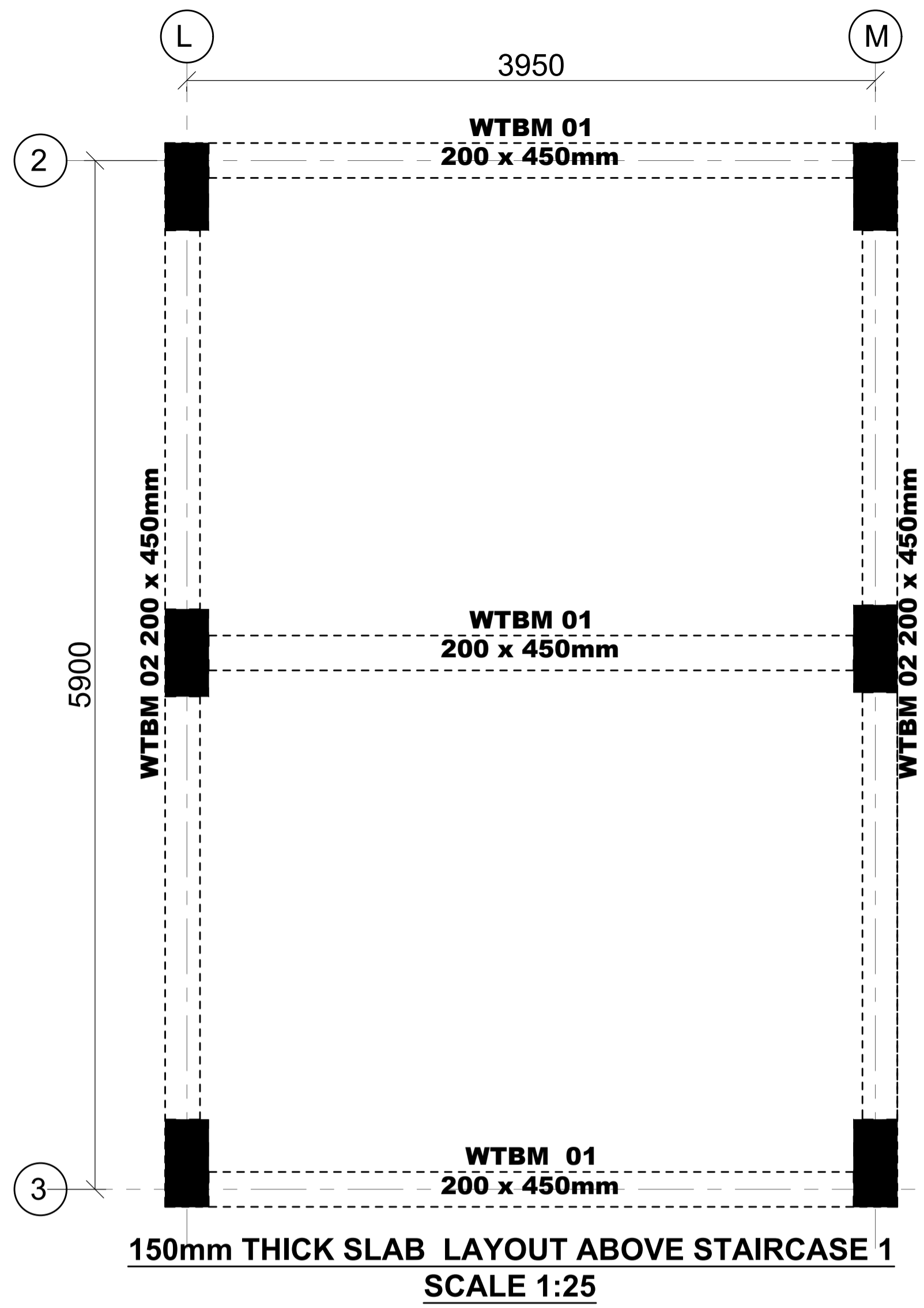
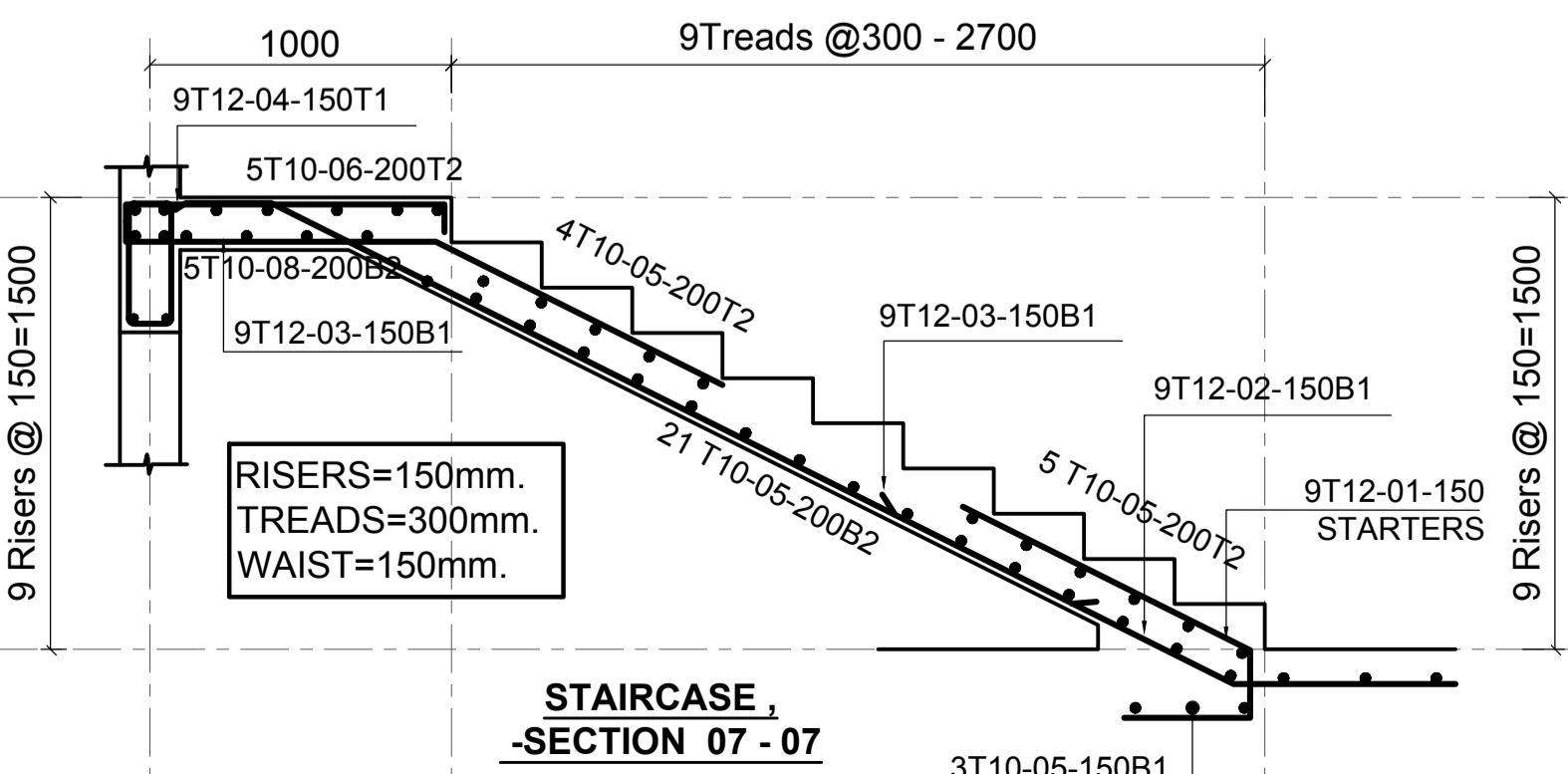
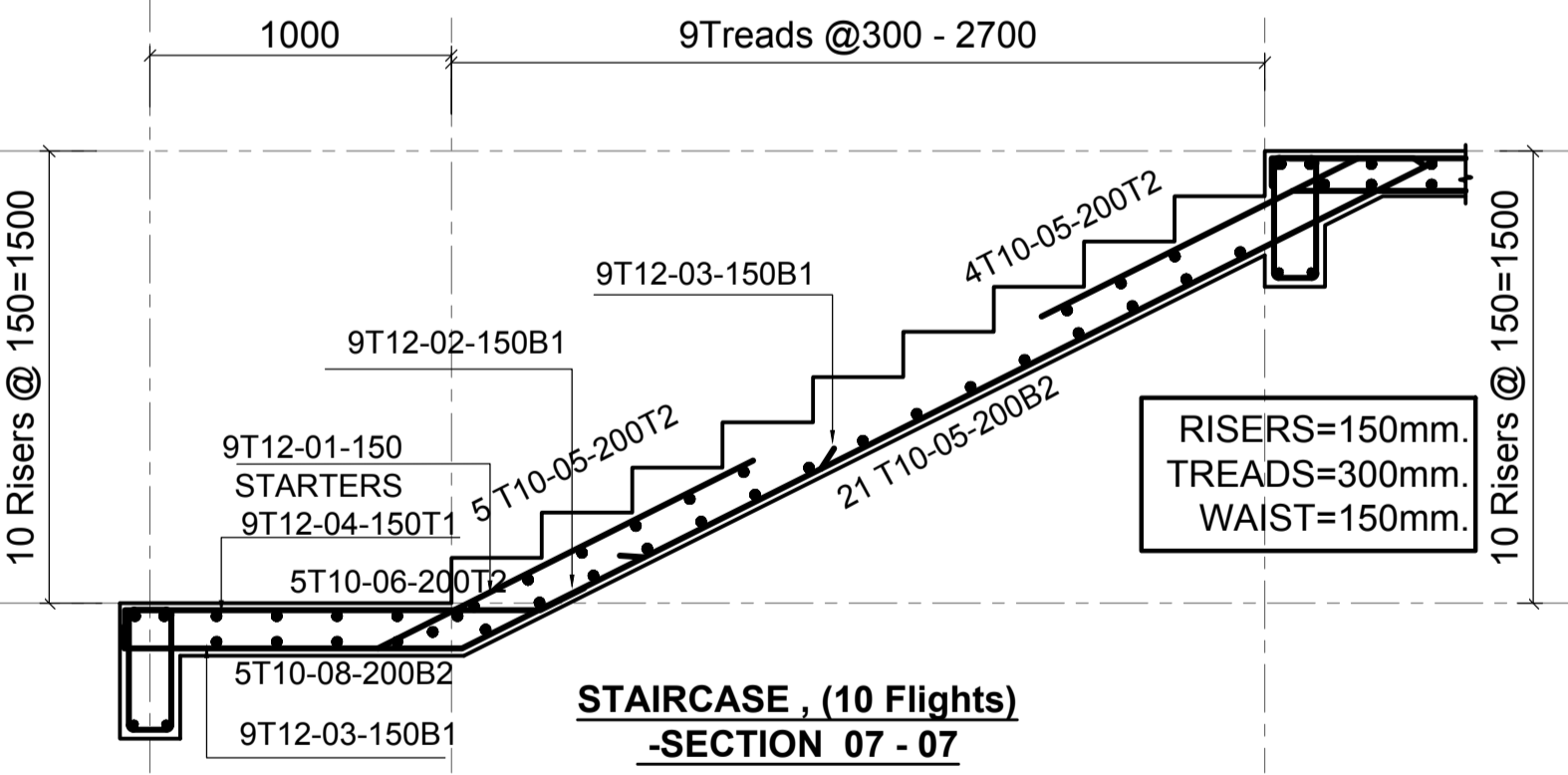
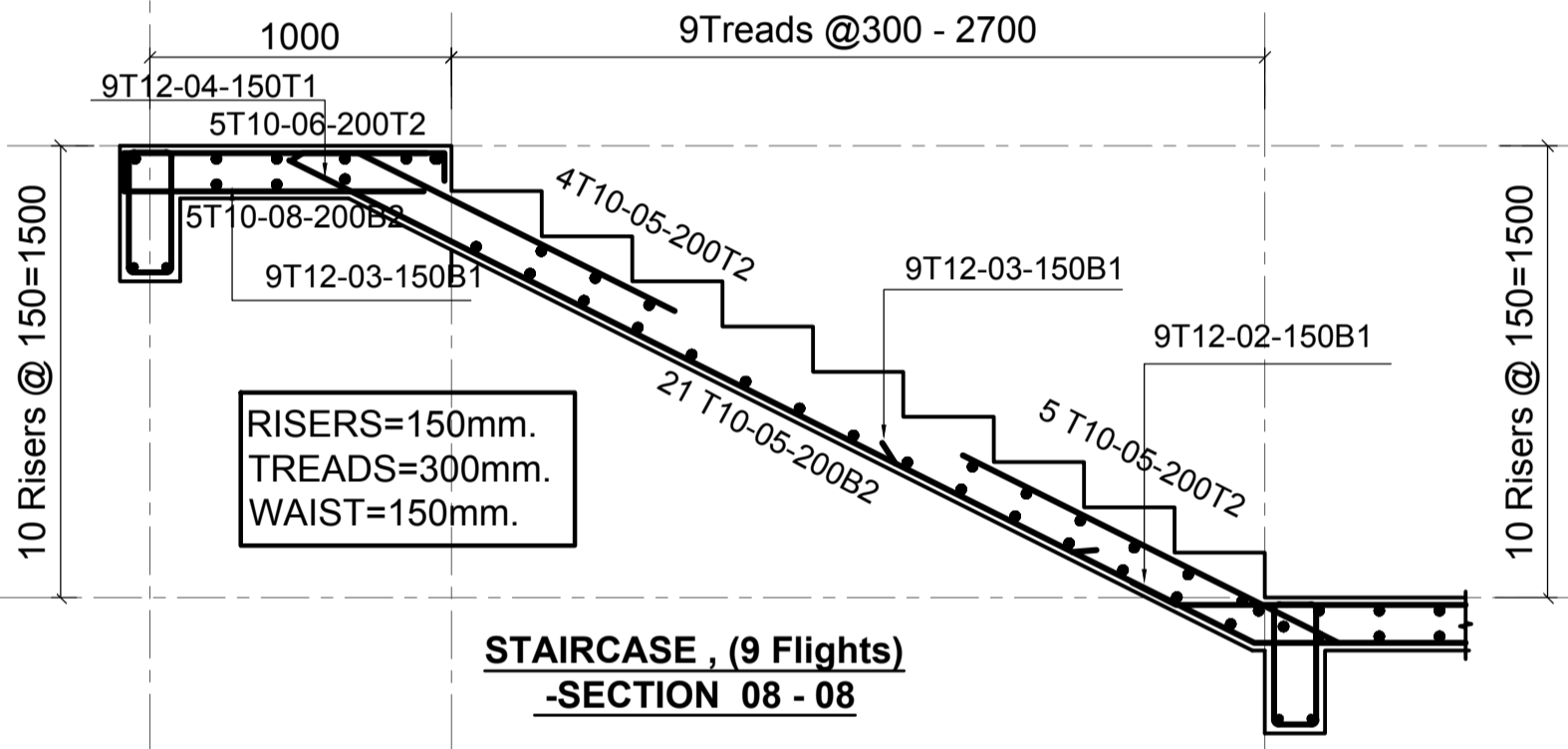
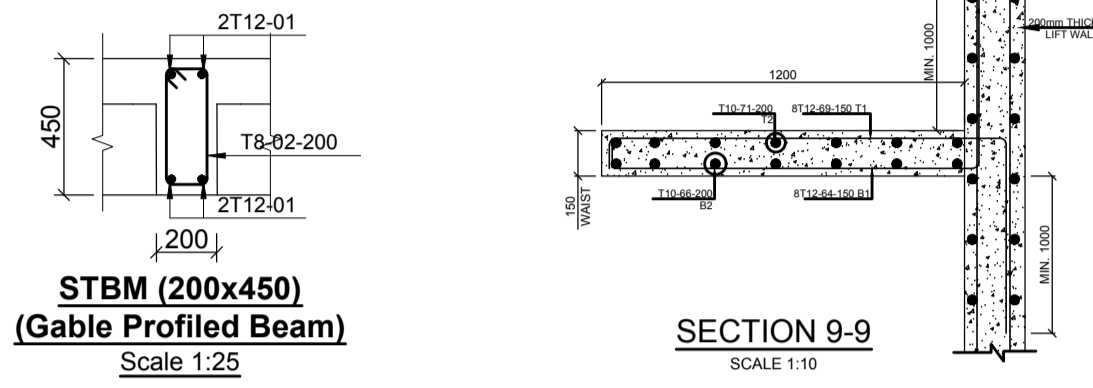

Project: PROPOSED AFFORDABLE HOUSING DEVELOPMENT (BLOCK TYPE B MARKET UNITS)  
 Title: STAIRCASE RC DETAILS  
 Client: MINISTRY OF LANDS, PUBLIC WORKS, HOUSING AND URBAN DEVELOPMENT  
 State Department: STATE DEPARTMENT FOR HOUSING AND URBAN DEVELOPMENT  
 Designed by: JMN  
 Checked by: JMN  
 Approved by: SECRETARY, HOUSING DEPARTMENT  
 Date: 13th March 2024  
 Scale: As shown  
 Drawing Number: AMP-C-9-B/LAB 3.0B  
 Revisions: [Table with columns for No., Description, Date]  
 NOTES:  
 1. All dimensions are in millimetres unless otherwise stated.  
 2. All reinforcements must be checked and approved by project structural engineer prior to concreting.  
 3. Concrete to be Class 25 mix and bedding concrete to be Class 15 mix.  
 4. Only figured dimensions to be taken from this drawing.  
 5. Any discrepancy in dimensions to be reported to the project consultants i.e architect or engineer.  
 6. Symbols: T-TMT Rebars to B S 4 461 T Top face, Bottom face  
 7. Cover to reinforcement: Slabs - 20mm, Beams - 25mm, Columns - 40mm, Foundations - 50mm  
 8. All structural steel to be grade 43A.  
 9. All structural steel to be painted with anti-rust primer paint.  
 10. All structural steel to be painted with anti-rust primer paint.

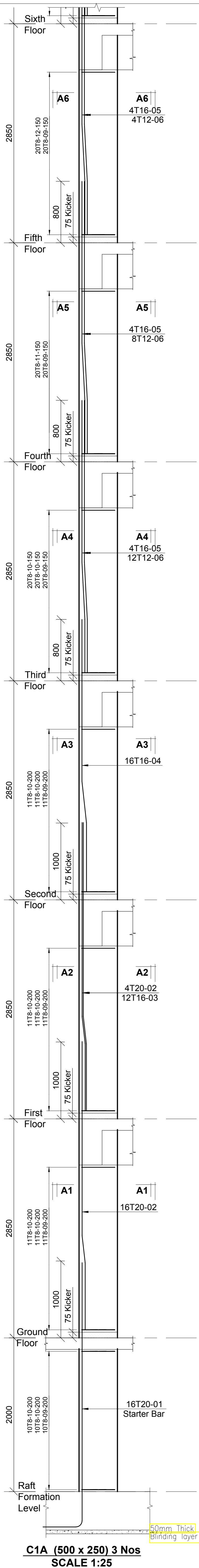

**C1A (500 x 250) 3 Nos**  
SCALE 1:25

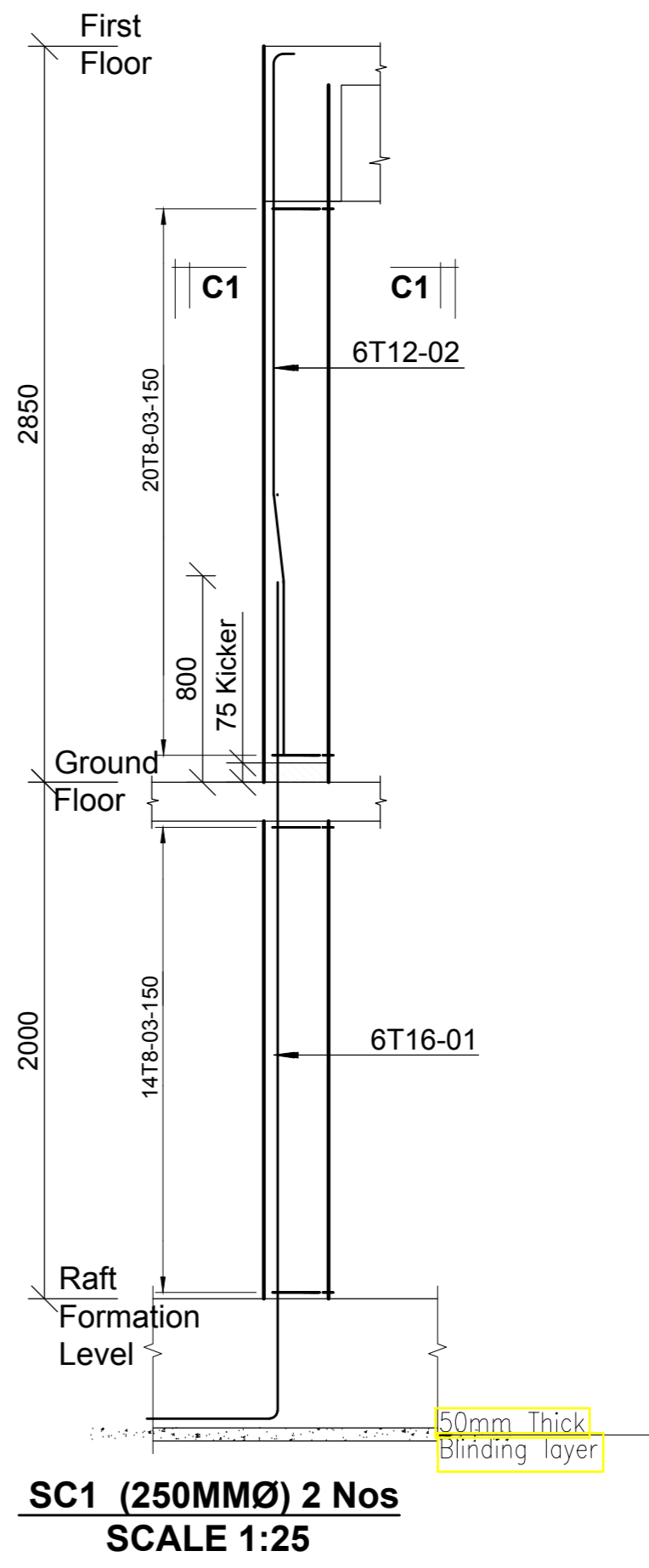
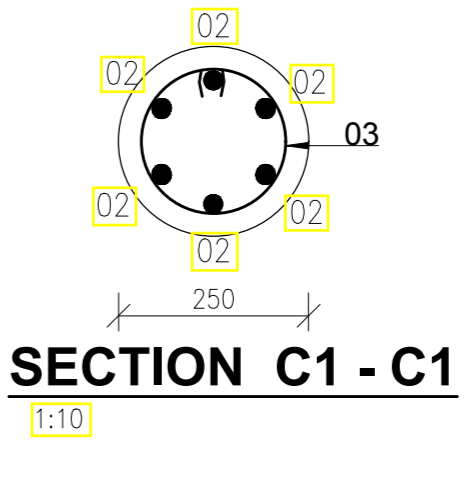
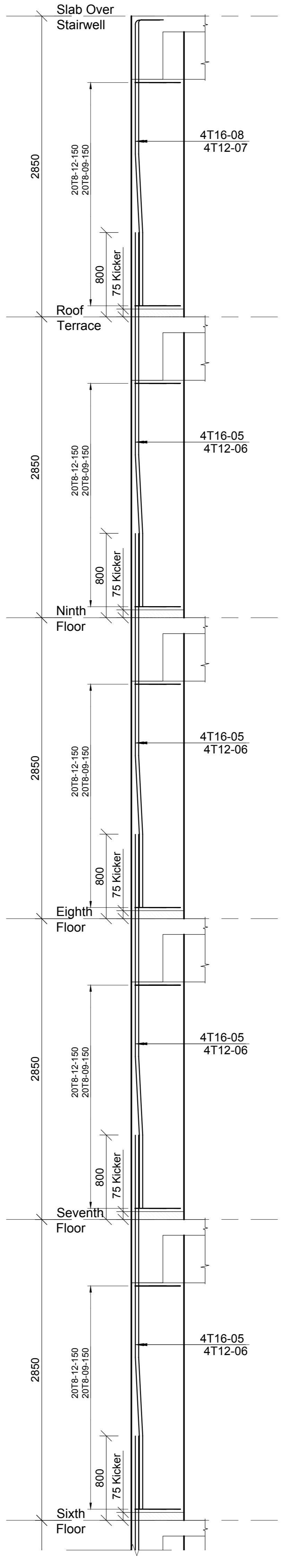
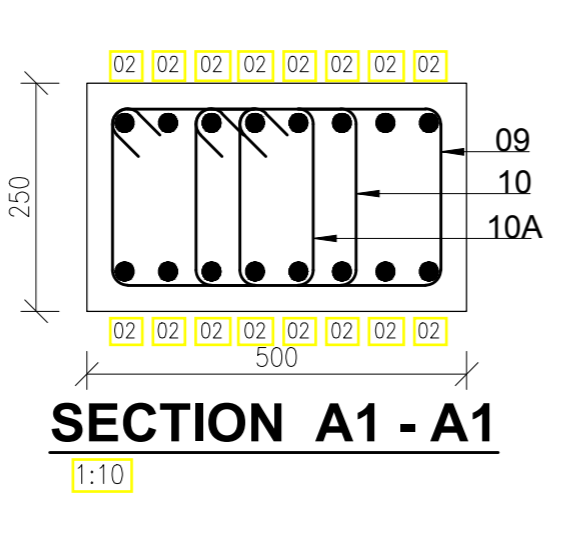
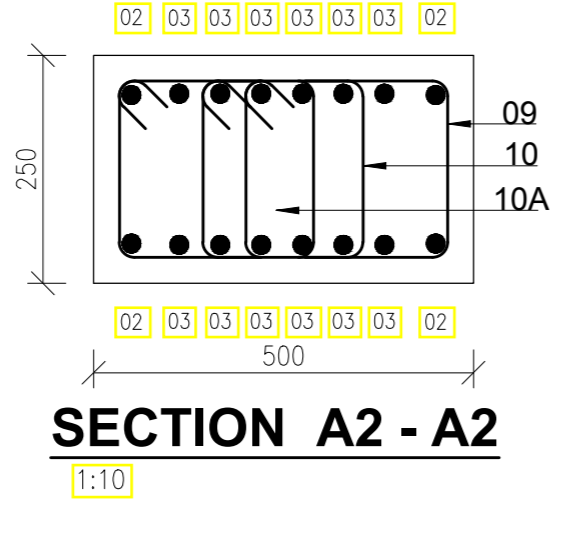
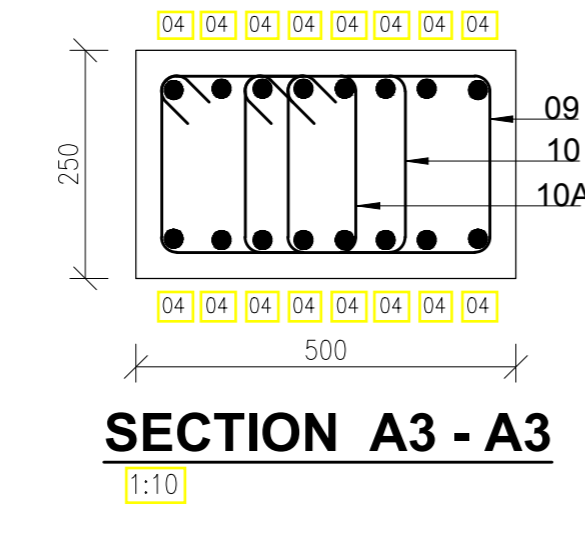
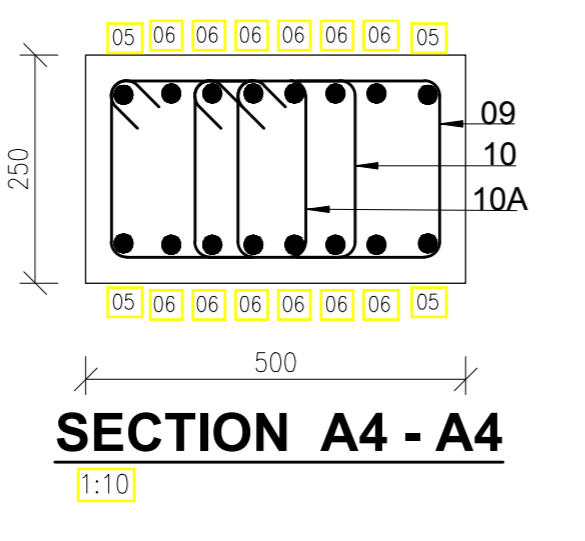
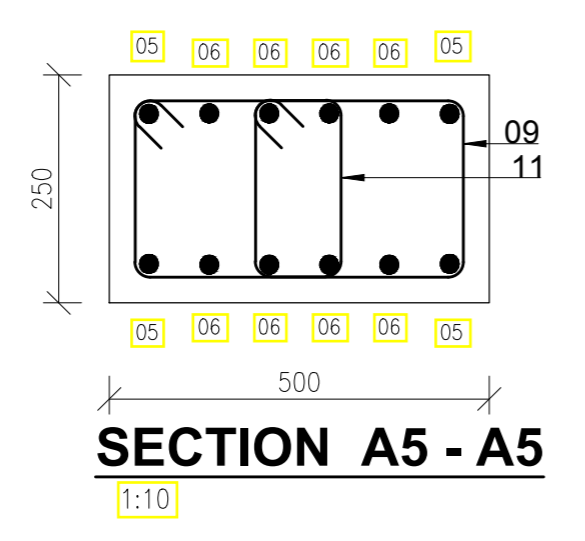
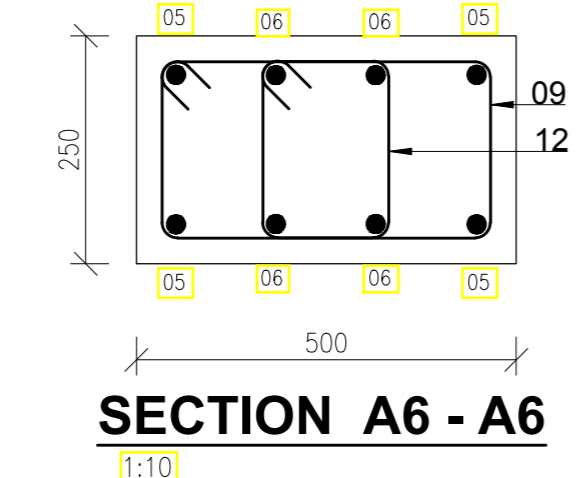

**SC1 (250MMØ) 2 Nos**  
SCALE 1:25

Revisions	
No.	Date

**Project**  
PROPOSED AFFORDABLE HOUSING DEVELOPMENT (BLOCK TYPE B MARKET UNITS)

**Title**  
COLUMN C1A RC DETAILS

**Designed by:** JMN  
**Checked by:** JMN

**Approved by:** SECRETARY, HOUSING DEPARTMENT

**Date:** 13th March 2024  
**Scale:** As shown

**Drawing Number:** AHP-G-9-BLKB-4.0B

**STRUCTURAL ENGINEER:**

**Client**  
MINISTRY OF LANDS, PUBLIC WORKS, HOUSING AND URBAN DEVELOPMENT

**STATE DEPARTMENT FOR HOUSING AND URBAN DEVELOPMENT**

- NOTES**
- All dimensions are in millimetres unless otherwise stated.
  - All reinforcements must be checked and approved by project structural engineer prior to concreting.
  - All reinforced concrete to be Class 25 mix and blinding concrete to be Class 15 mix.
  - Only figured dimensions to be taken from this drawing.
  - Any discrepancy /indimensions to be reported to the project consultants i.e architect or engineer.

- Symbols: T-TMT Rebars to B S 4 461 ; T - Top face ; B - Bottom face
- Cover to reinforcement: Slabs - 20mm, Beams - 25mm, Columns - 40mm, Foundations - 50mm
- All structural steel to be grade 43A.
- All welds are 6mm thick.
- All structural steel to be painted with anti-rust primer paint.

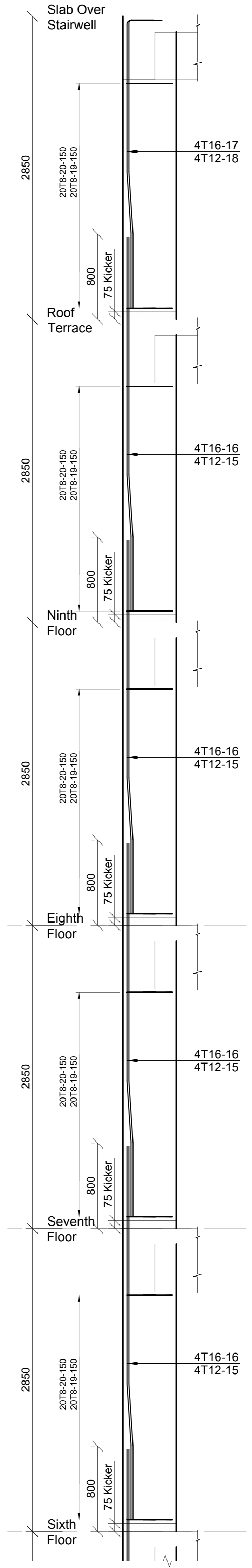
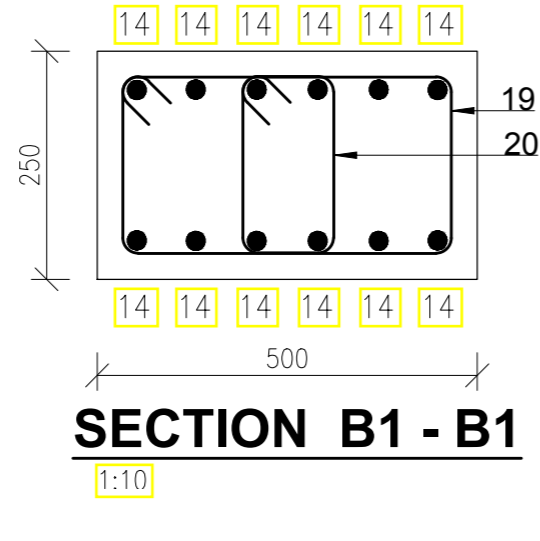
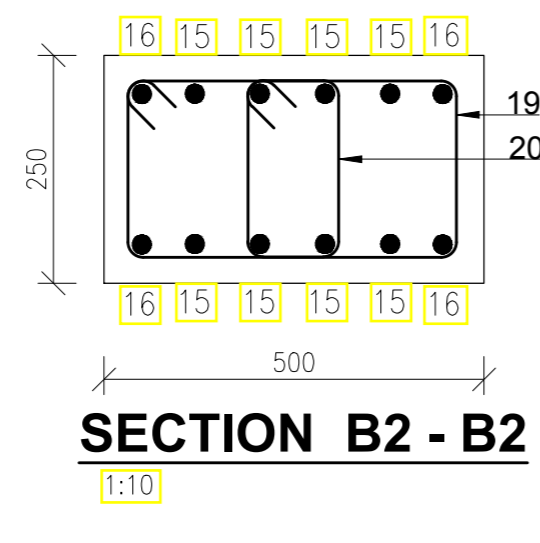
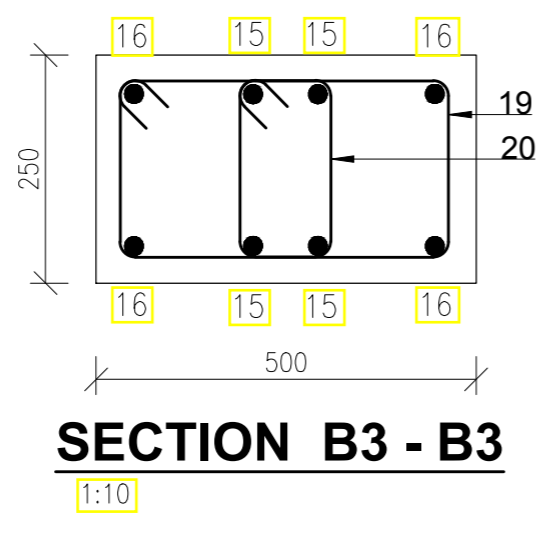
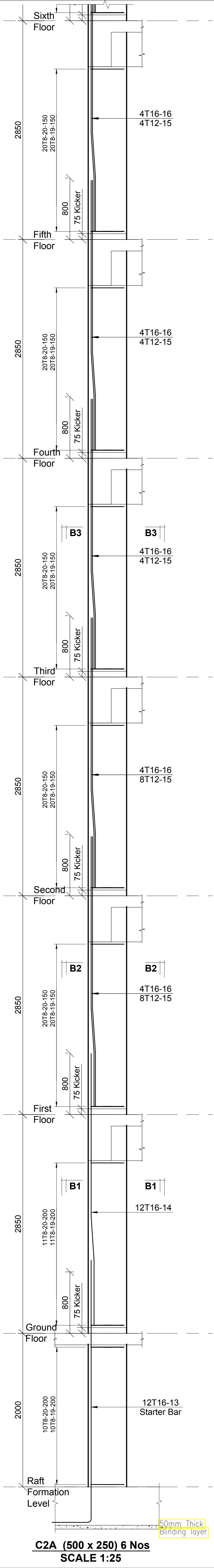

Revisions	
No.	Description

Project: PROPOSED AFFORDABLE HOUSING DEVELOPMENT (BLOCK TYPE B MARKET UNITS)  
 Title: COLUMN C2A RC DETAILS

Designed by: JMN  
 Checked by: JMN  
 Approved by: SECRETARY, HOUSING DEPARTMENT  
 Date: 13th March 2024  
 Drawing Number: AHP-G+9-BLKB 4-1B

STRUCTURAL ENGINEER:

Client: MINISTRY OF LANDS, PUBLIC WORKS, HOUSING AND URBAN DEVELOPMENT  
 STATE DEPARTMENT FOR HOUSING AND URBAN DEVELOPMENT

6. Symbols: T-TMT Rebars to B S 4 461 : T - Top face  
 B - Bottom face  
 7. Cover to reinforcement, Slabs - 20mm,  
 Beams - 25mm, Columns - 40mm, Foundations - 50mm  
 8. All structural steel be grade 43A.  
 9. All welds are 6mm thick.  
 10. All structural steel to be painted with anti-rust primer paint.

- NOTES  
 1. All dimensions are in millimetres unless otherwise stated.  
 2. All reinforcements must be checked and approved by project structural engineer prior to concreting.  
 3. All reinforced concrete to be Class 25 mix and blinding concrete to be Class 15 mix.  
 4. Only figured dimensions to be taken from this drawing.  
 5. Any discrepancy/indimensions to be reported to the project consultants i.e architect or engineer.



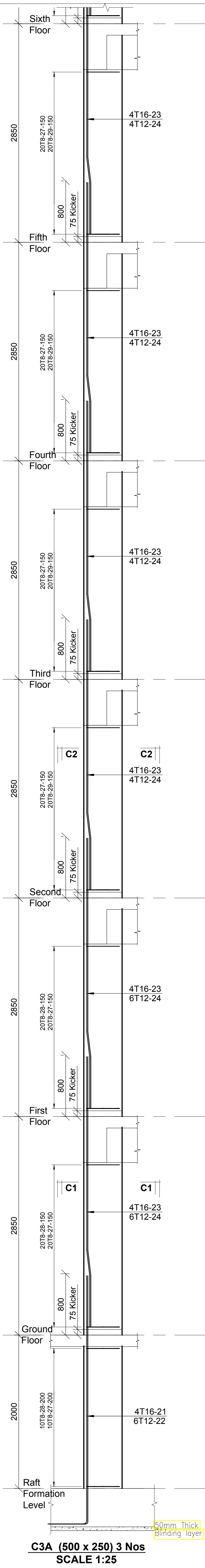

**C3A (500 x 250) 3 Nos**  
**SCALE 1:25**

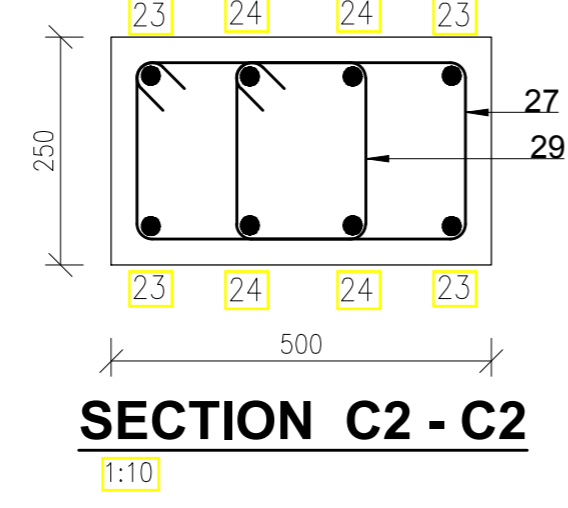

**SECTION C2 - C2**  
**1:10**

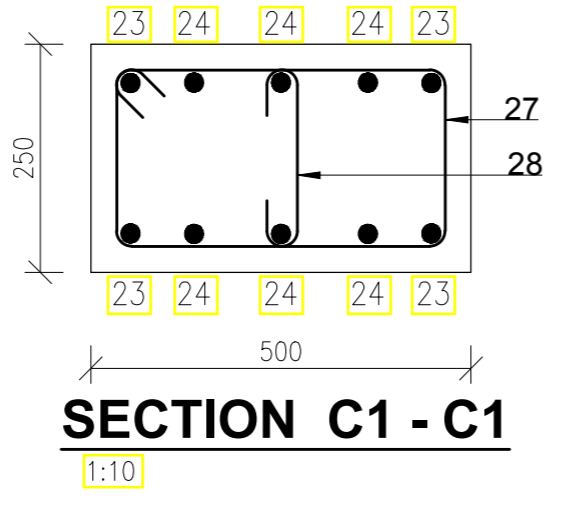

**SECTION C1 - C1**  
**1:10**

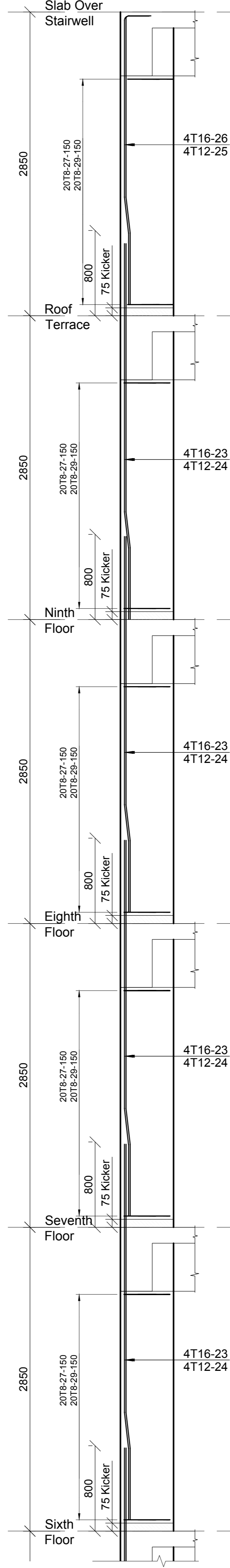

- NOTES**
- All dimensions are in millimetres unless otherwise stated.
  - All reinforcements must be checked and approved by project structural engineer prior to concreting.
  - All reinforced concrete to be Class 25 mix and blinding concrete to be Class 15 mix.
  - Only figured dimensions to be taken from this drawing.
  - Any discrepancy / dimensions to be reported to the project consultants i.e architect or engineer.

6. Symbols: T-TMT Rebars to B S 4 461 ; T - Top face  
 7. Cover to reinforcement: Slabs - 20mm, Beams - 25mm, Columns - 40mm, Foundations - 50mm  
 8. All structural steel be grade 43A.  
 9. All welds are 6mm thick.  
 10. All structural steel to be painted with anti-rust primer paint.

Client  
**MINISTRY OF LANDS, PUBLIC WORKS, HOUSING AND URBAN DEVELOPMENT**  
 STATE DEPARTMENT FOR HOUSING AND URBAN DEVELOPMENT

STRUCTURAL ENGINEER:

Designed by: JMN  
 Checked by: JMN  
 Approved by: SECRETARY, HOUSING DEPARTMENT  
 Date: 13th March 2024  
 Drawing Number: AHP-G-9-BLKB 4.2B  
 Scale: As shown

Project  
**PROPOSED AFFORDABLE HOUSING DEVELOPMENT (BLOCK TYPE B MARKET UNITS)**  
 Title  
**COLUMN C3A RC DETAILS**

Revisions		Date
No.	Description	

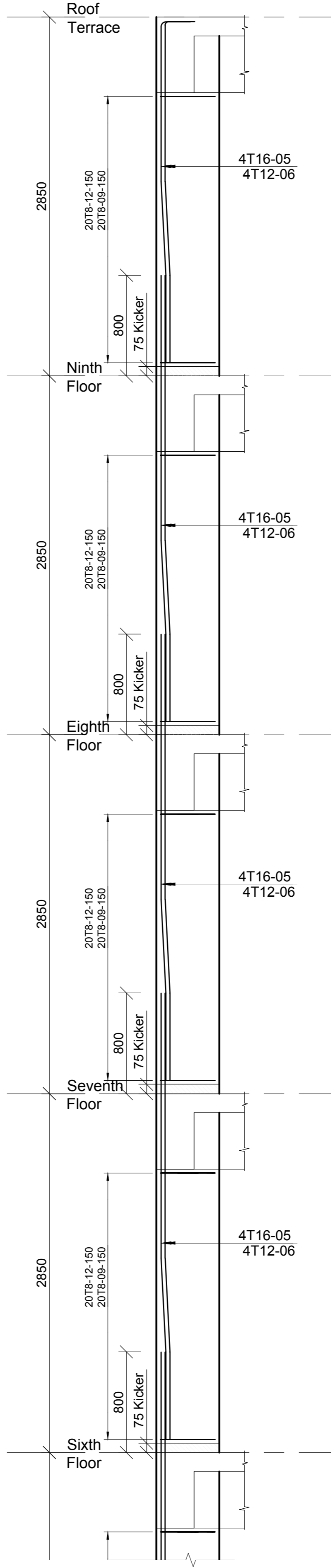
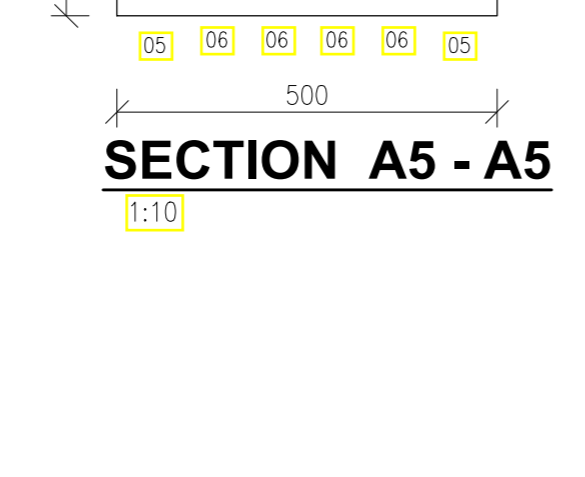
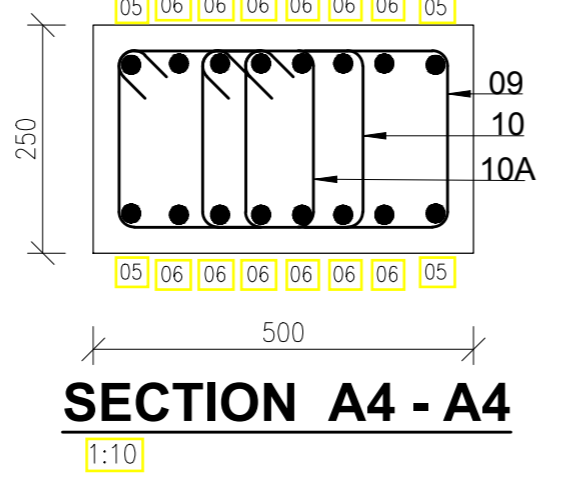
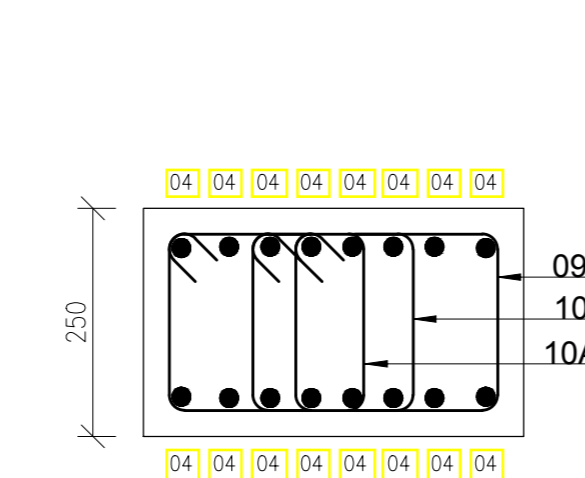
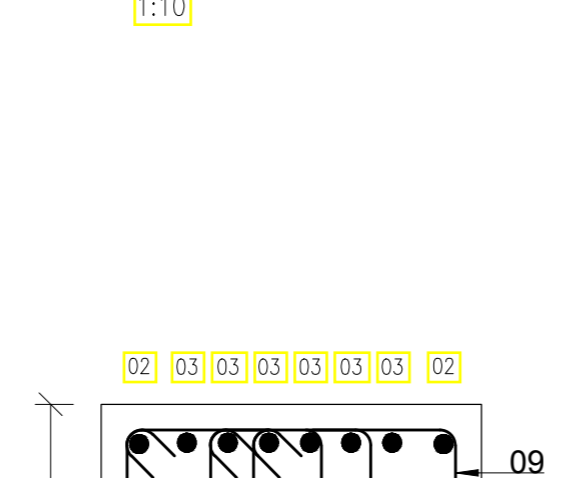
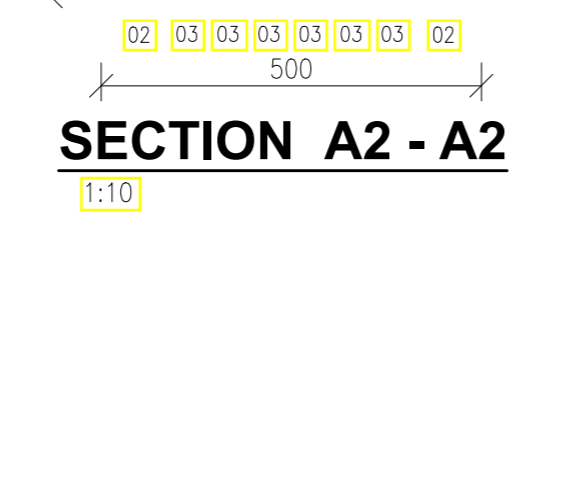
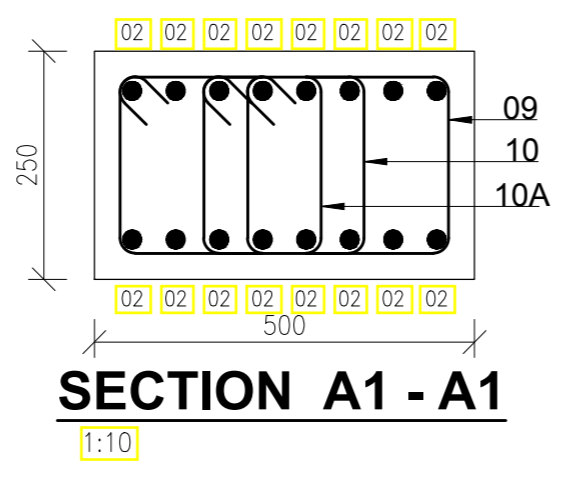
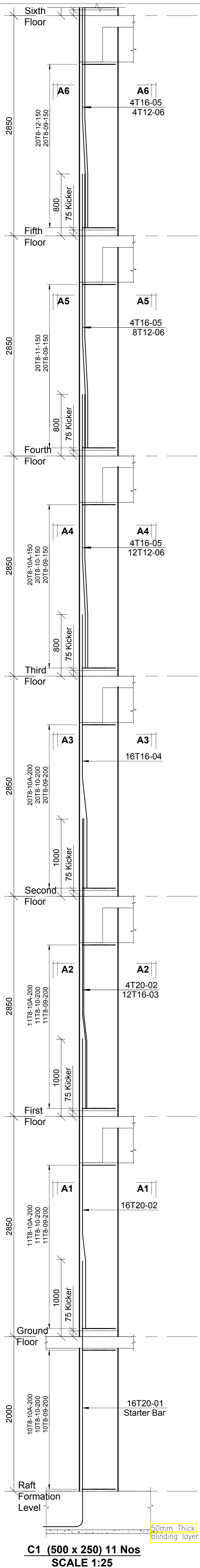

Revisions	
No.	Description

Project: PROPOSED AFFORDABLE HOUSING DEVELOPMENT (BLOCK TYPE B MARKET UNITS)  
 Title: COLUMN C1 RC DETAILS

Designed by: JMN  
 Checked by: JMN  
 Approved by: SECRETARY, HOUSING DEPARTMENT  
 Date: 13th March 2024  
 Scale: As shown  
 Drawing Number: AHP-G+9-BLKB 4.3B

STRUCTURAL ENGINEER:

Client: MINISTRY OF LANDS, PUBLIC WORKS, HOUSING AND URBAN DEVELOPMENT  
 STATE DEPARTMENT FOR HOUSING AND URBAN DEVELOPMENT

6. Symbols: T-TMT Rebars to B S 4 461 ; T - Top face  
 B - Bottom face  
 7. Cover to reinforcement: Slabs - 20mm,  
 Beams - 25mm, Columns - 40mm, Foundations -50mm  
 8. All structural steel be grade 43A.  
 9. All welds are 6mm thick  
 10. All structural steel to be painted with anti-rust primer paint.

- NOTES  
 1. All dimensions are in millimetres unless otherwise stated.  
 2. All reinforcements must be checked and approved by project structural engineer prior to concreting.  
 3. All reinforced concrete to be Class 25 mix and blinding concrete to be Class 15 mix.  
 4. Only figured dimensions to be taken from this drawing.  
 5. Any discrepancy /indimensions to be reported to the project consultants i.e architect or engineer.

C1 (500 x 250) 11 Nos  
 SCALE 1:25

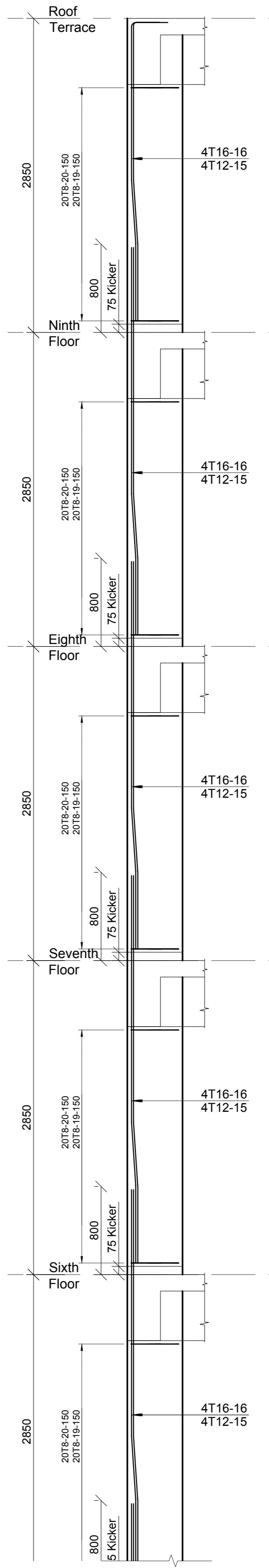
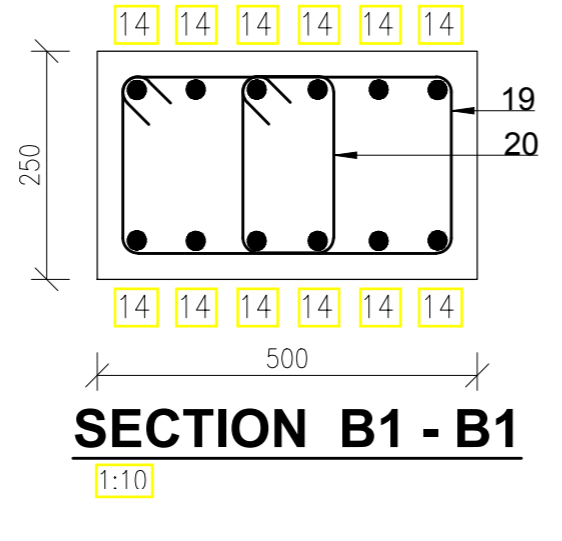
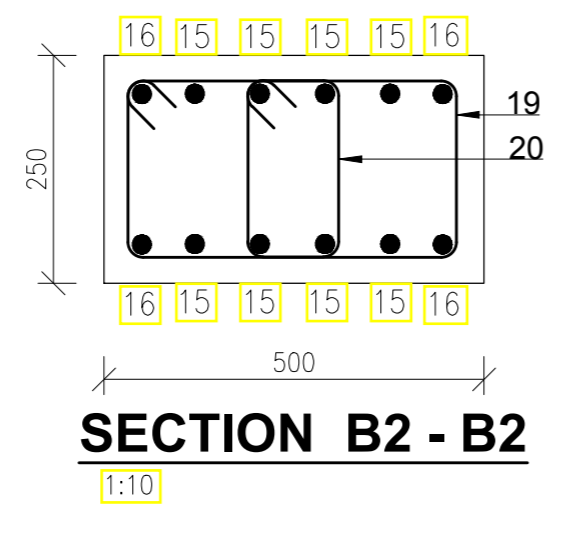
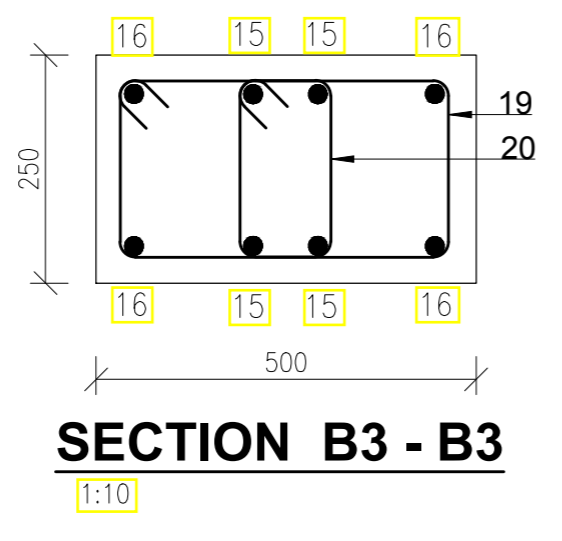
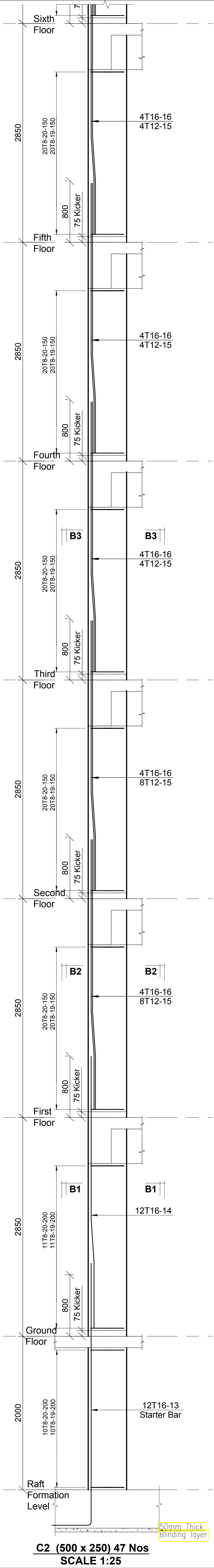

Revisions	
No.	Description

Project: PROPOSED AFFORDABLE HOUSING DEVELOPMENT (BLOCK TYPE B MARKET UNITS)  
 Title: COLUMN C2 RC DETAILS

Designed by: JMN  
 Checked by: JMN  
 Approved by: SECRETARY, HOUSING DEPARTMENT  
 Date: 13th March 2024  
 Scale: As shown  
 Drawing Number: AHP-G+9-BLKB 4-4B

STRUCTURAL ENGINEER:

Client: MINISTRY OF LANDS, PUBLIC WORKS, HOUSING AND URBAN DEVELOPMENT  
 STATE DEPARTMENT FOR HOUSING AND URBAN DEVELOPMENT

6. Symbols: T - TMT Rebars to B S 4 461 ; T - Top face  
 B - Bottom face  
 7. Cover to reinforcement, Slabs - 20mm,  
 Beams - 25mm, Columns - 40mm, Foundations - 50mm  
 8. All structural steel be grade 43A.  
 9. All welds are 6mm thick.  
 10. All structural steel to be painted with anti-rust primer paint.

NOTES  
 1. All dimensions are in millimetres unless otherwise stated.  
 2. All reinforcements must be checked and approved by project structural engineer prior to concreting.  
 3. All reinforced concrete to be Class 25 mix and blinding concrete to be Class 15 mix.  
 4. Only figured dimensions to be taken from this drawing.  
 5. Any discrepancy / dimensions to be reported to the project consultants i.e architect or engineer.

C2 (500 x 250) 47 Nos  
 SCALE 1:25

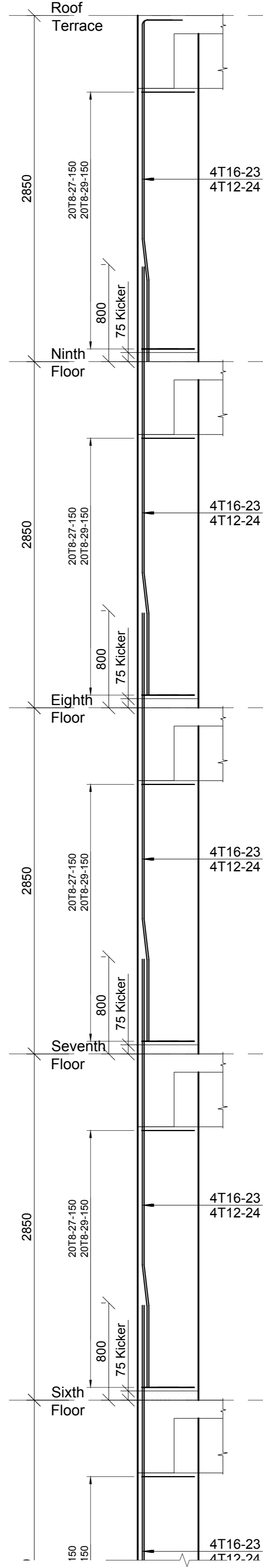
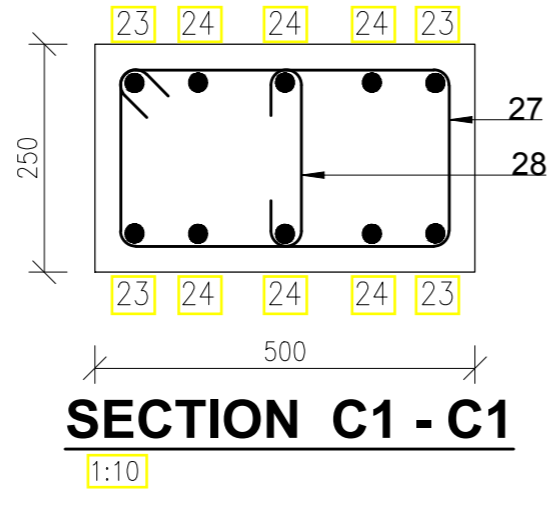
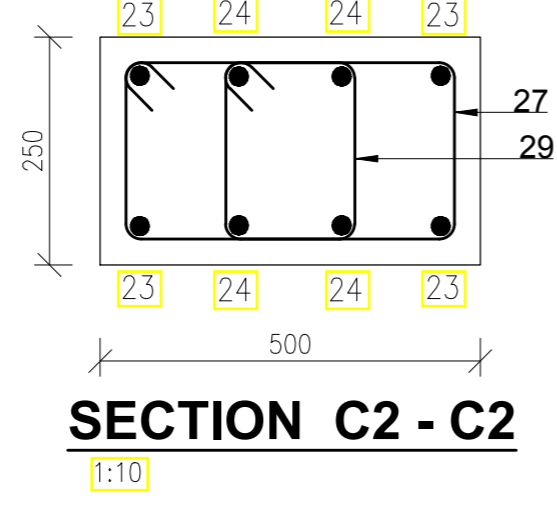
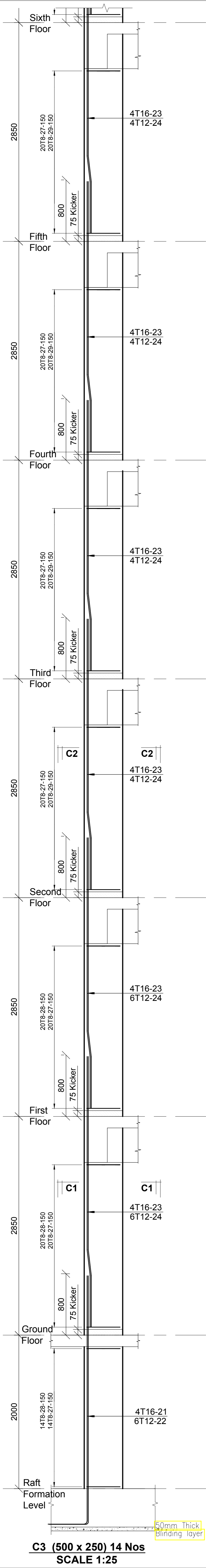

**C3 (500 x 250) 14 Nos**  
SCALE 1:25

**SECTION C1 - C1**  
1:10

**SECTION C2 - C2**  
1:10

**NOTES**  
1. All dimensions are in millimetres unless otherwise stated.  
2. All reinforcements must be checked and approved by project structural engineer prior to concreting.  
3. All reinforced concrete to be Class 25 mix and blinding concrete to be Class 15 mix.  
4. Only figured dimensions to be taken from this drawing.  
5. Any discrepancy / dimensions to be reported to the project consultants i.e architect or engineer.

6. Symbols: T-TMT Rebars to B S 4 461 ; T - Top face ; B - Bottom face  
7. Cover to reinforcement: Slabs - 20mm, Beams - 25mm, Columns - 40mm, Foundations - 50mm  
8. All structural steel be grade 43A.  
9. All welds are 6mm thick.  
10. All structural steel to be painted with anti-rust primer paint.

Client  
**MINISTRY OF LANDS, PUBLIC WORKS, HOUSING AND URBAN DEVELOPMENT**  
STATE DEPARTMENT FOR HOUSING AND URBAN DEVELOPMENT

STRUCTURAL ENGINEER:

Designed by: JMN | Checked by: JMN  
Approved by: SECRETARY, HOUSING DEPARTMENT  
Date: 13th March 2024 | Scale: As shown  
Drawing Number: AHP-G-9-BLK-4.5B

Project  
**PROPOSED AFFORDABLE HOUSING DEVELOPMENT (BLOCK TYPE B MARKET UNITS)**  
Title  
**COLUMN C3 RC DETAILS**

Revisions	
No.	Description / Date

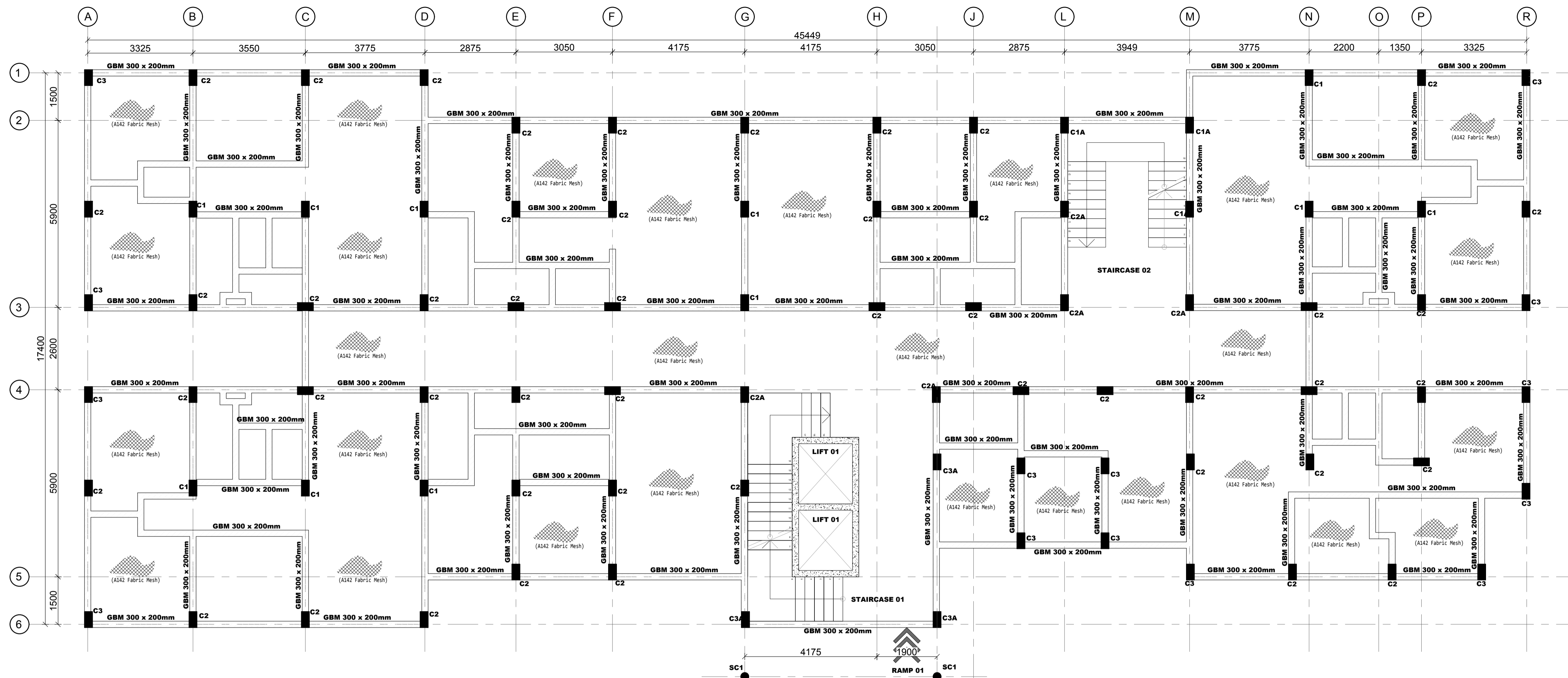

**GROUND FLOOR LAYOUT**  
 (100mm Thick Solid Slab With BRC Mesh A142 on top )  
 SCALE 1:75

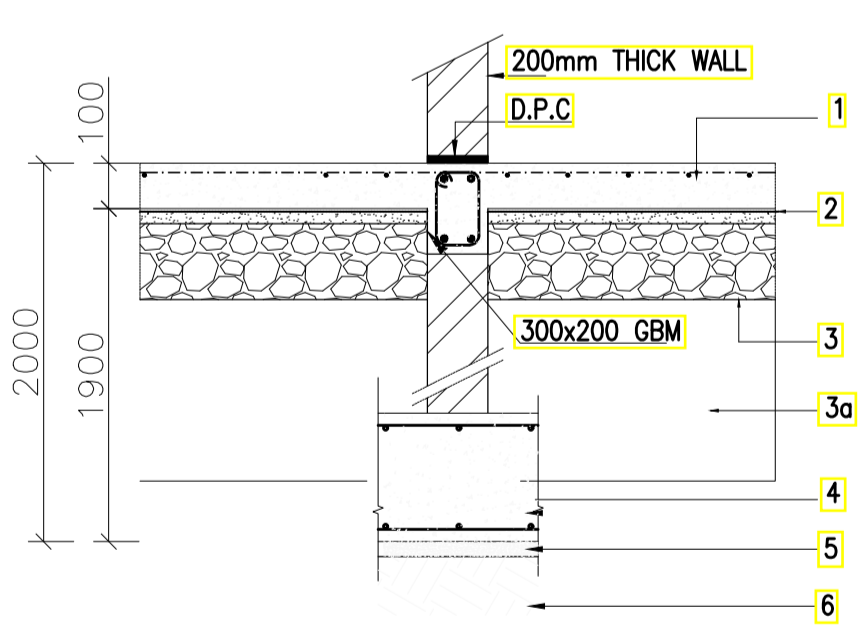

**TYPICAL INTERNAL FOUNDATION WALLING SECTION**  
 1:25

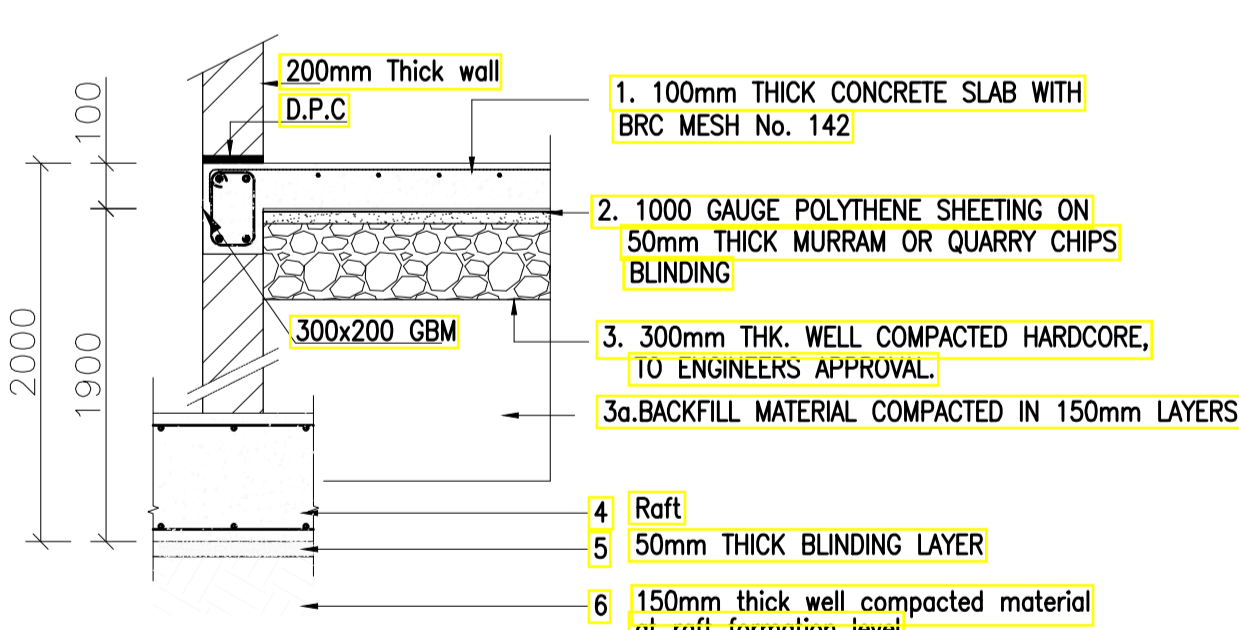

**TYPICAL INTERNAL FOUNDATION WALLING SECTION**  
 1:25

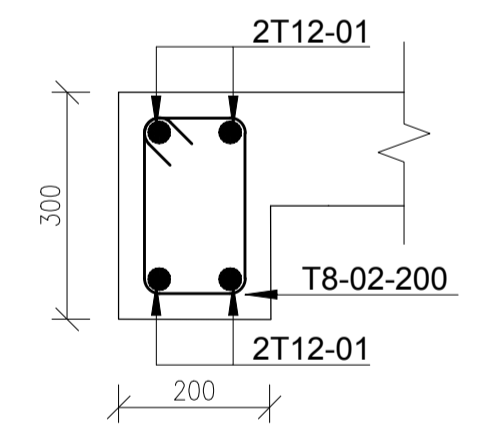

**GBM (300 X 200mm)**  
 Scale 1:10

**NOTES**  
 1. All dimensions are in millimetres unless otherwise stated.  
 2. All reinforcements must be checked and approved by project structural engineer prior to concreting.  
 3. All reinforced concrete to be Class 25 mix and blinding concrete to be Class 15 mix.  
 4. Only figured dimensions to be taken from this drawing.  
 5. Any discrepancy in dimensions to be reported to the project consultants i.e architect or engineer.

6. Symbols: T-TMT Rebars to B S 4 461 : T - Top face B - Bottom face
7. Cover to reinforcement; Slabs - 20mm, Beams - 25mm, Columns - 40mm, Foundations - 50mm
8. All structural steel be grade 43A.
9. All welds are 6mm thick.
10. All structural steel to be painted with anti-rust primer paint.

Client  
**MINISTRY OF LANDS, PUBLIC WORKS, HOUSING AND URBAN DEVELOPMENT**  
 STATE DEPARTMENT FOR HOUSING AND URBAN DEVELOPMENT

STRUCTURAL ENGINEER:

Designed by: JMN Checked by: JMN  
 Approved by: SECRETARY, HOUSING DEPARTMENT  
 Date: 13th March 2024 Scale: As shown  
 Drawing Number: AHP-G-9-BLKB 5.0B

Project  
**PROPOSED AFFORDABLE HOUSING DEVELOPMENT (BLOCK TYPE B MARKET UNITS)**  
 Title  
**GROUND FLOOR LAYOUT DETAILS**

Revisions		
No.	Description	Date

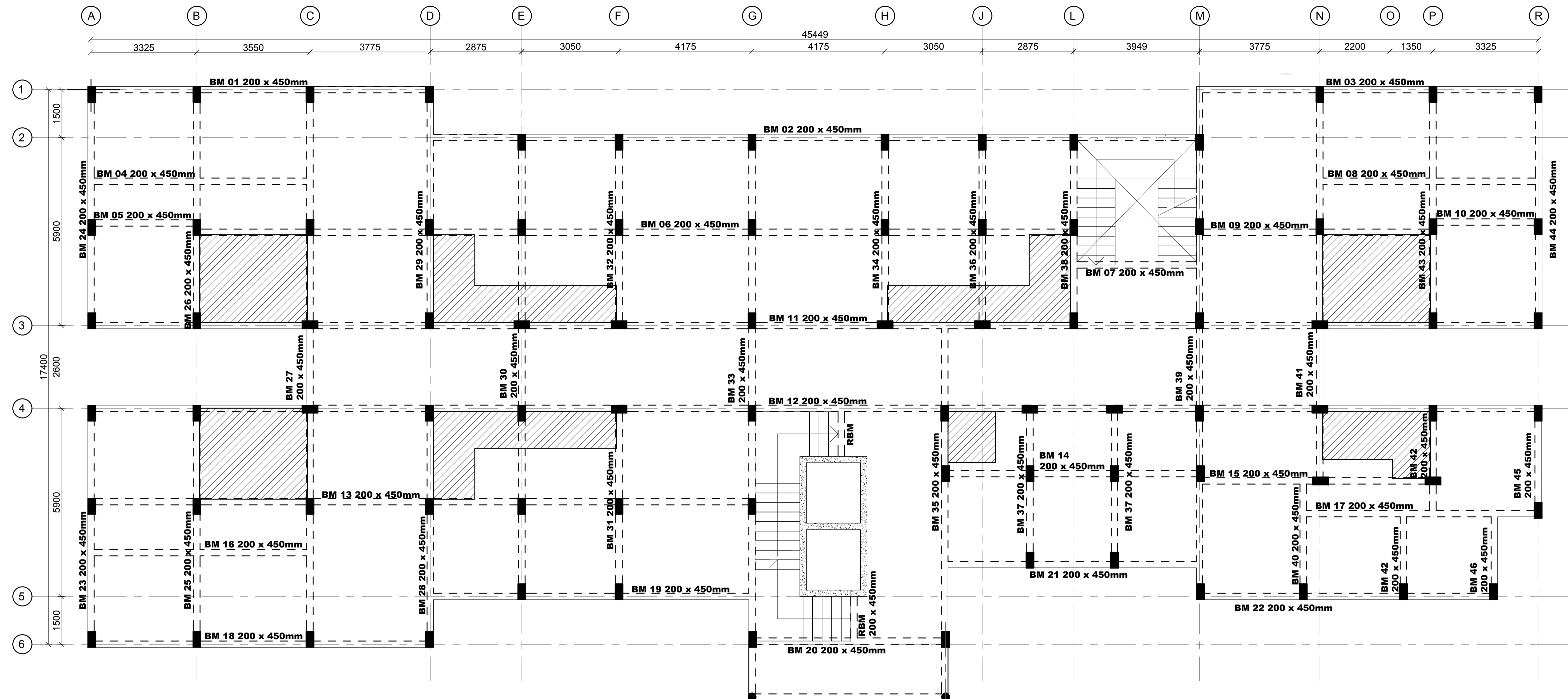

**FIRST FLOOR SLAB LAYOUT**  
**130 MM THICK SOLID SLAB AND 150 MM THICK SLAB IN WET AREAS(HATCHED)**  
**SCALE 1:75**

**NOTE:**  
 -First floor slab balcony to be waterproofed with physical barrier waterproofing membrane such as APP or equivalent.  
 -APP membrane to be protected using screed and concrete interlocking tiles

**NOTES**

1. All dimensions are in millimetres unless otherwise stated.
2. All reinforcements must be checked and approved by project structural engineer prior to concreting.
3. All reinforced concrete to be Class 25 mix and blinding concrete to be Class 15 mix.
4. Only figured dimensions to be taken from this drawing.
5. Any discrepancy in dimensions to be reported to the project consultants i.e architect or engineer.

6. Symbols; T-TMT Rebars to B S 4 461 : T - Top face  
B - Bottom face
7. Cover to reinforcement; Slabs - 20mm,  
Beams - 25mm, Columns - 40mm, Foundations -50mm
8. All structural steel be grade 43A.
9. All welds are 6mm thick.
10. All structural steel to be painted with anti-rust primer paint.

Client  
**MINISTRY OF LANDS, PUBLIC WORKS,  
 HOUSING AND URBAN DEVELOPMENT**  
 STATE DEPARTMENT FOR HOUSING AND URBAN  
 DEVELOPMENT

STRUCTURAL ENGINEER:

Designed by: JMN      Checked by: JMN  
 Approved by: SECRETARY, HOUSING DEPARTMENT  
 Date: 13th March 2024      Scale: As shown  
 Drawing Number: AHP-G+9-BLKB 5.1B

Project  
**PROPOSED AFFORDABLE  
 HOUSING DEVELOPMENT  
 (BLOCK TYPE B MARKET UNITS)**  
 Title  
**FIRST FLOOR LAYOUT DETAILS**

Revisions		
No.	Description	Date

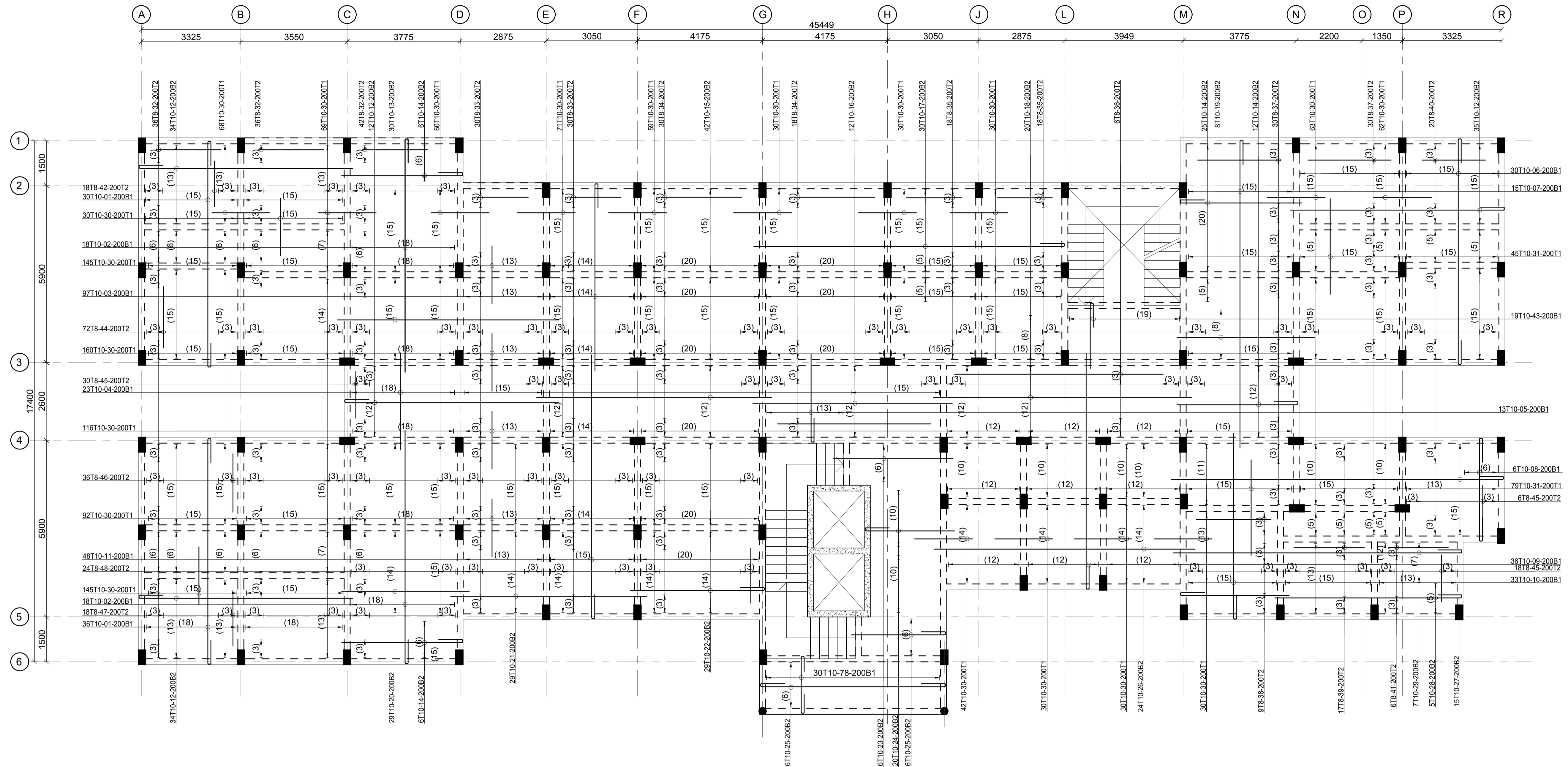

**FIRST FLOOR SLAB LAYOUT**  
**130 MM THICK SOLID SLAB AND 150 MM THICK SLAB IN WET AREAS**  
**SCALE 1:75**

**NOTES**  
 1. All dimensions are in millimetres unless otherwise stated.  
 2. All reinforcements must be checked and approved by project structural engineer prior to concreting.  
 3. All reinforced concrete to be Class 25 mix and blinding concrete to be Class 15 mix.  
 4. Only figured dimensions to be taken from this drawing.  
 5. Any discrepancy in dimensions to be reported to the project consultants i.e architect or engineer.

6. Symbols: T-TMT Rebars to B S 4 461 : T - Top face  
 B - Bottom face  
 7. Cover to reinforcement; Slabs - 20mm,  
 Beams - 25mm, Columns - 40mm, Foundations - 50mm  
 8. All structural steel be grade 43A.  
 9. All welds are 6mm thick.  
 10. All structural steel to be painted with anti-rust primer paint.

Client  
**MINISTRY OF LANDS, PUBLIC WORKS,  
 HOUSING AND URBAN DEVELOPMENT**  
 STATE DEPARTMENT FOR HOUSING AND URBAN  
 DEVELOPMENT

STRUCTURAL ENGINEER:  
 \_\_\_\_\_  
 \_\_\_\_\_

Designed by: JMN      Checked by: JMN  
 Approved by: SECRETARY, HOUSING DEPARTMENT  
 Date: 13th March 2024      Scale: As shown  
 Drawing Number: AHP-G+9-BLKB 5.2B

Project  
**PROPOSED AFFORDABLE  
 HOUSING DEVELOPMENT  
 (BLOCK TYPE B MARKET UNITS)**  
 Title  
**FIRST FLOOR RC SLAB DETAILS**

Revisions		
No.	Description	Date

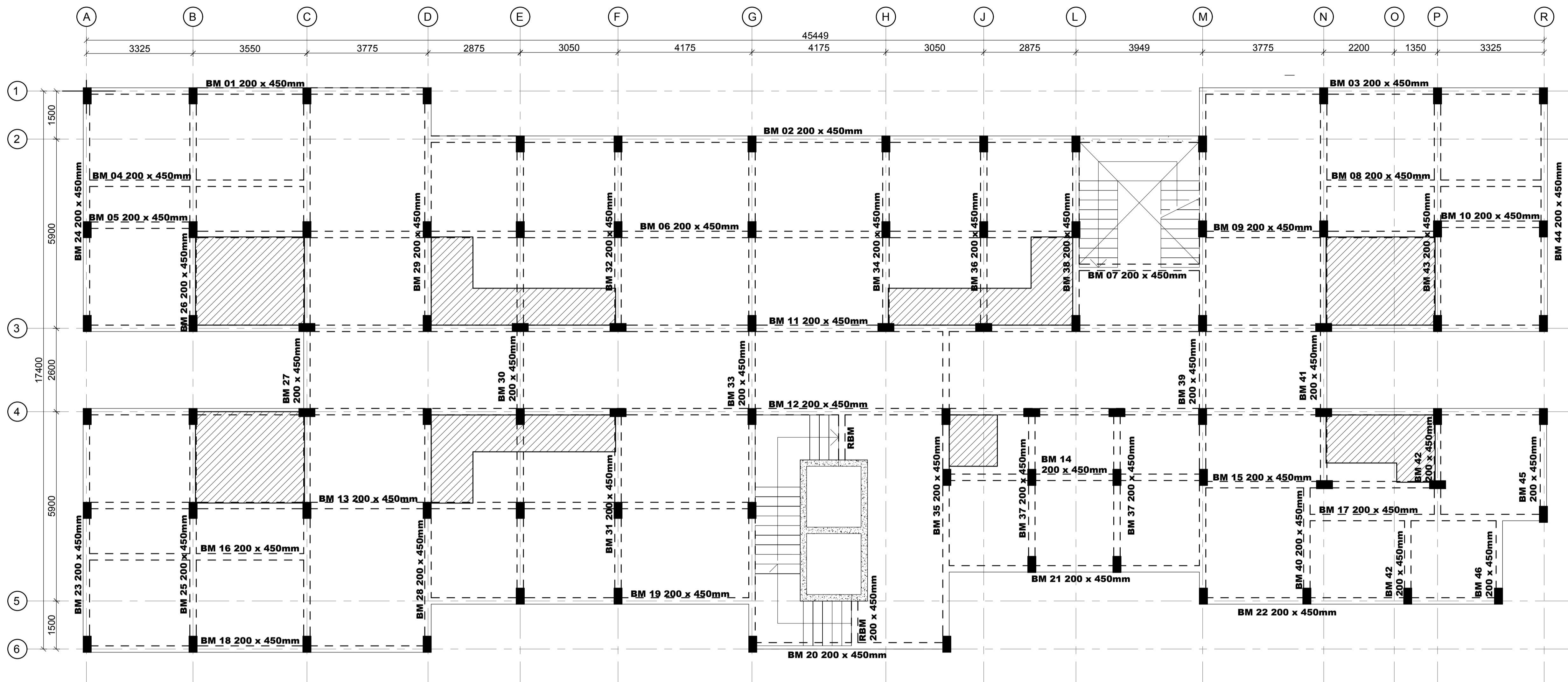

TYPICAL FLOOR SLAB LAYOUT  
 130 MM THICK SOLID SLAB AND 150 MM THICK SLAB IN WET AREAS(HATCHED)  
 SCALE 1:75

NOTES

- All dimensions are in millimetres unless otherwise stated.
- All reinforcements must be checked and approved by project structural engineer prior to concreting.
- All reinforced concrete to be Class 25 mix and blinding concrete to be Class 15 mix.
- Only figured dimensions to be taken from this drawing.
- Any discrepancy in dimensions to be reported to the project consultants i.e architect or engineer.

- Symbols; T-TMT Rebars to B S 4 461 : T - Top face  
B - Bottom face
- Cover to reinforcement; Slabs - 20mm,  
Beams - 25mm, Columns - 40mm, Foundations - 50mm
- All structural steel be grade 43A.
- All welds are 6mm thick.
- All structural steel to be painted with anti-rust primer paint.

Client  
 MINISTRY OF LANDS, PUBLIC WORKS,  
 HOUSING AND URBAN DEVELOPMENT  
 STATE DEPARTMENT FOR HOUSING AND URBAN  
 DEVELOPMENT

STRUCTURAL ENGINEER:

Designed by: JMN      Checked by: JMN  
 Approved by: SECRETARY, HOUSING DEPARTMENT  
 Date: 13th March 2024      Scale: As shown  
 Drawing Number: AHP-G+9-BLKB 6.0B

Project  
 PROPOSED AFFORDABLE  
 HOUSING DEVELOPMENT  
 (BLOCK TYPE B MARKET UNITS)  
 Title  
 TYPICAL FLOOR SLAB LAYOUT DETAILS

Revisions		
No.	Description	Date



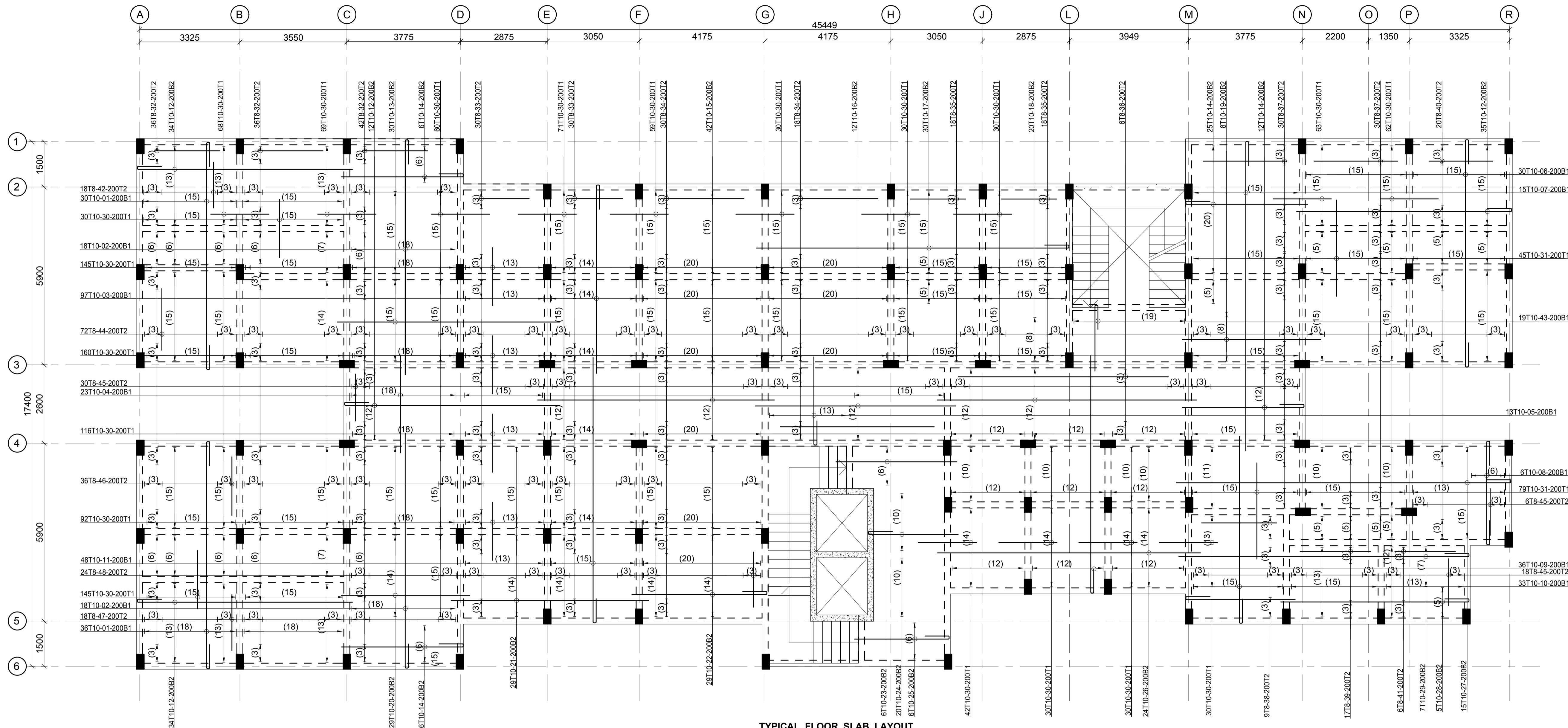

**TYPICAL FLOOR SLAB LAYOUT**  
**130 MM THICK SOLID SLAB AND 150 MM THICK SLAB IN WET AREAS**  
**SCALE 1:75**

**NOTES**  
 1. All dimensions are in millimetres unless otherwise stated.  
 2. All reinforcements must be checked and approved by project structural engineer prior to concreting.  
 3. All reinforced concrete to be Class 25 mix and blinding concrete to be Class 15 mix.  
 4. Only figured dimensions to be taken from this drawing.  
 5. Any discrepancy in dimensions to be reported to the project consultants i.e architect or engineer.

6. Symbols; T-TMT Rebars to B S 4 461 : T - Top face  
 B - Bottom face  
 7. Cover to reinforcement; Slabs - 20mm,  
 Beams - 25mm, Columns - 40mm, Foundations - 50mm  
 8. All structural steel be grade 43A.  
 9. All welds are 6mm thick.  
 10. All structural steel to be painted with anti-rust primer paint.

Client  
**MINISTRY OF LANDS, PUBLIC WORKS,  
 HOUSING AND URBAN DEVELOPMENT**  
 STATE DEPARTMENT FOR HOUSING AND URBAN  
 DEVELOPMENT

STRUCTURAL ENGINEER:

Designed by: JMN Checked by: JMN  
 Approved by: SECRETARY, HOUSING DEPARTMENT  
 Date: 13th March 2024 Scale: As shown  
 Drawing Number: AHP-G+9-BLKB 6.1B

Project  
**PROPOSED AFFORDABLE  
 HOUSING DEVELOPMENT  
 (BLOCK TYPE B MARKET UNITS)**  
 Title  
**TYPICAL FLOOR SLAB REBAR DETAILS**

Revisions		
No.	Description	Date

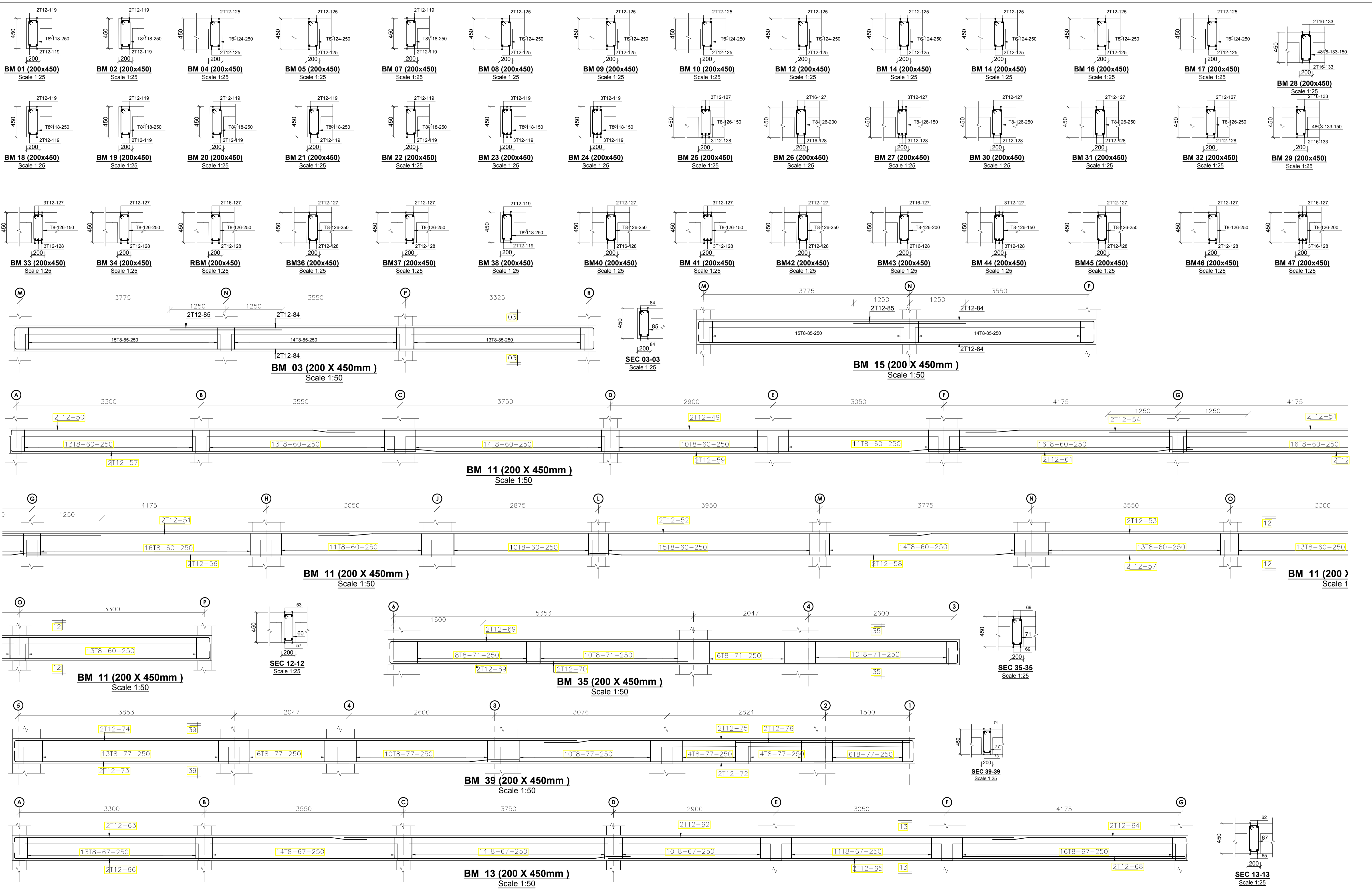

**NOTES**

- All dimensions are in millimetres unless otherwise stated.
- All reinforcements must be checked and approved by project structural engineer prior to concreting.
- All reinforced concrete to be Class 25 mix and blinding concrete to be Class 15 mix.
- Only figured dimensions to be taken from this drawing.
- Any discrepancy in dimensions to be reported to the project consultants i.e architect or engineer.

- Symbols; T-TMT Rebars to B S 4 461 : T - Top face  
B - Bottom face
- Cover to reinforcement; Slabs - 20mm,  
Beams - 25mm, Columns - 40mm, Foundations -50mm
- All structural steel be grade 43A.
- All welds are 6mm thick.
- All structural steel to be painted with anti-rust primer paint.

Client  
**MINISTRY OF LANDS, PUBLIC WORKS,  
HOUSING AND URBAN DEVELOPMENT**  
STATE DEPARTMENT FOR HOUSING AND URBAN  
DEVELOPMENT

STRUCTURAL ENGINEER:

Designed by: JMN      Checked by: JMN  
Approved by: SECRETARY, HOUSING DEPARTMENT  
Date: 13th March 2024      Scale: As shown  
Drawing Number: AHP-G+9-BLK B 6.2B

Project  
**PROPOSED AFFORDABLE  
HOUSING DEVELOPMENT  
(BLOCK TYPE B MARKET UNITS)**  
Title  
**BEAMS RC DETAILS**

Revisions		
No.	Description	Date

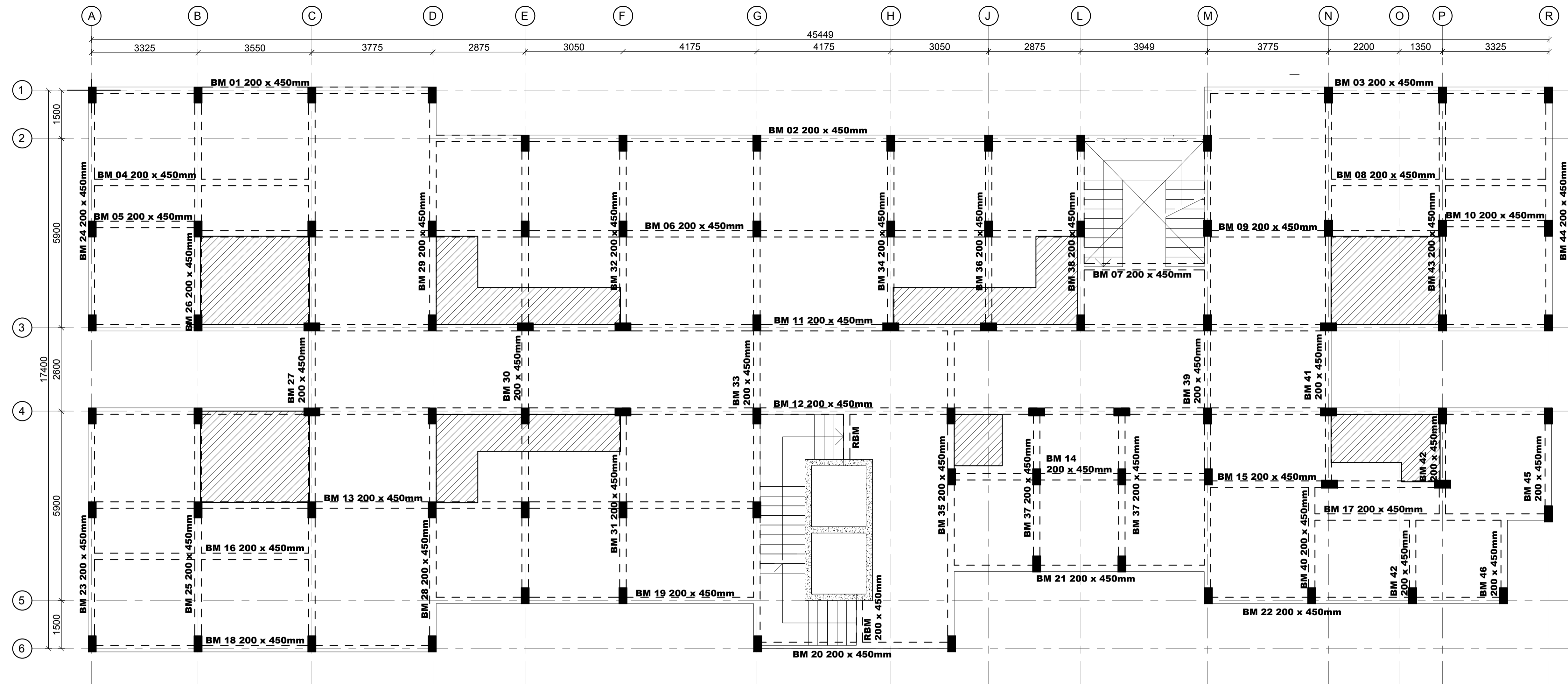

**ROOF TERRACE FLOOR SLAB REBAR DETAILS**  
150 MM THICK SLAB

**NOTE:**  
-Terrace floor slab to be waterproofed with physical barrier waterproofing membrane such as APP or equivalent.  
-APP membrane to be protected using screed and concrete interlocking tiles

**NOTES**  
1. All dimensions are in millimetres unless otherwise stated.  
2. All reinforcements must be checked and approved by project structural engineer prior to concreting.  
3. All reinforced concrete to be Class 25 mix and blinding concrete to be Class 15 mix.  
4. Only figured dimensions to be taken from this drawing.  
5. Any discrepancy in dimensions to be reported to the project consultants i.e architect or engineer.

6. Symbols; T-TMT Rebars to B S 4 461 : T - Top face  
B - Bottom face  
7. Cover to reinforcement; Slabs - 20mm,  
Beams - 25mm, Columns - 40mm, Foundations - 50mm  
8. All structural steel be grade 43A.  
9. All welds are 6mm thick.  
10. All structural steel to be painted with anti-rust primer paint.

Client  
**MINISTRY OF LANDS, PUBLIC WORKS,  
HOUSING AND URBAN DEVELOPMENT**  
STATE DEPARTMENT FOR HOUSING AND URBAN  
DEVELOPMENT

STRUCTURAL ENGINEER:

Designed by: JMN Checked by: JMN  
Approved by: SECRETARY, HOUSING DEPARTMENT  
Date: 13th March 2024 Scale: As shown  
Drawing Number: AHP-G+9-BLKB 7.0B

Project  
**PROPOSED AFFORDABLE  
HOUSING DEVELOPMENT  
(BLOCK TYPE B MARKET UNITS)**  
Title  
**ROOF TERRACE FLOOR  
SLAB LAYOUT DETAILS**

Revisions		
No.	Description	Date

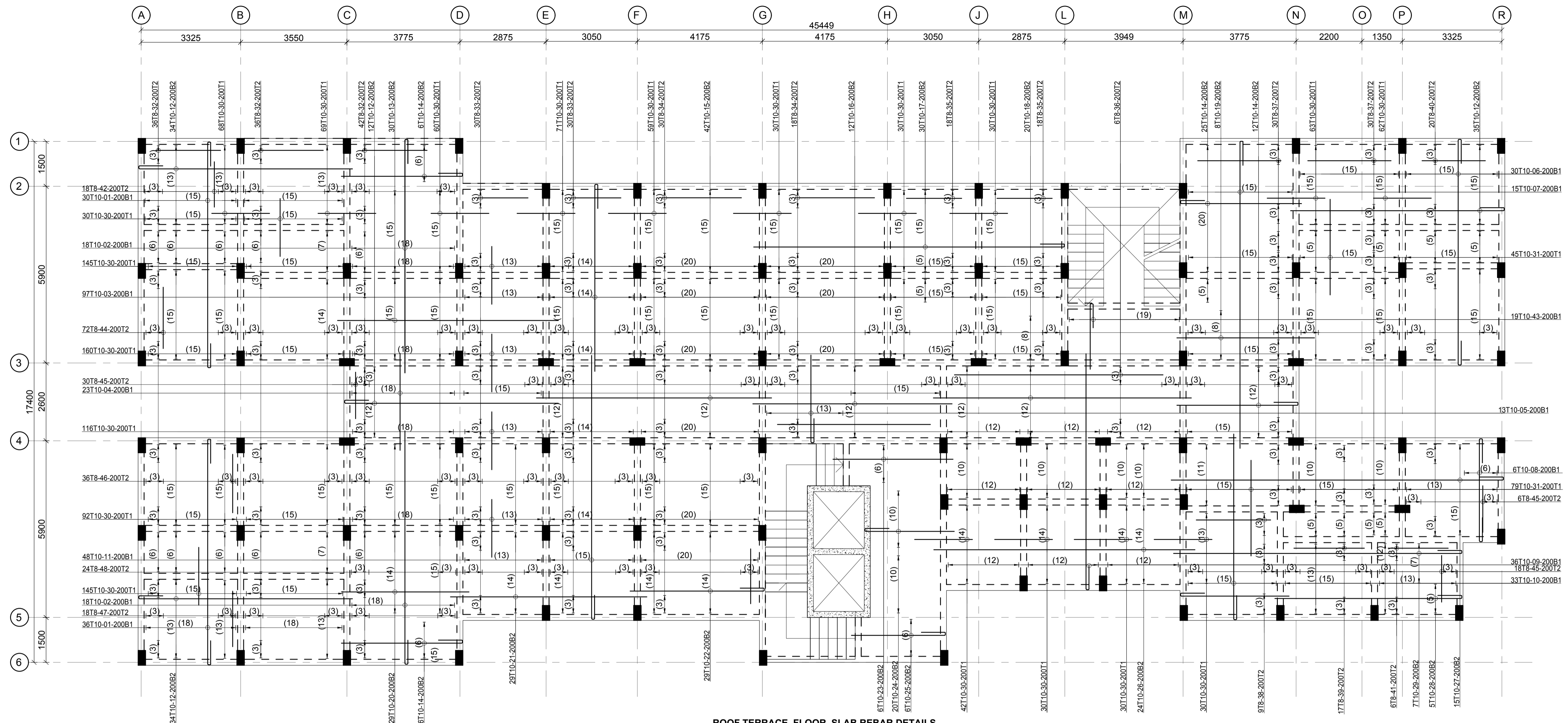

**ROOF TERRACE FLOOR SLAB REBAR DETAILS**  
**150 MM THICK SLAB**

**NOTES**  
 1. All dimensions are in millimetres unless otherwise stated.  
 2. All reinforcements must be checked and approved by project structural engineer prior to concreting.  
 3. All reinforced concrete to be Class 25 mix and blinding concrete to be Class 15 mix.  
 4. Only figured dimensions to be taken from this drawing.  
 5. Any discrepancy in dimensions to be reported to the project consultants i.e architect or engineer.

6. Symbols; T-TMT Rebars to B S 4 461 : T - Top face  
 B - Bottom face  
 7. Cover to reinforcement; Slabs - 20mm,  
 Beams - 25mm, Columns - 40mm, Foundations - 50mm  
 8. All structural steel be grade 43A.  
 9. All welds are 6mm thick.  
 10. All structural steel to be painted with anti-rust primer paint.

Client  
**MINISTRY OF LANDS, PUBLIC WORKS,  
 HOUSING AND URBAN DEVELOPMENT**  
 STATE DEPARTMENT FOR HOUSING AND URBAN  
 DEVELOPMENT

STRUCTURAL ENGINEER:

Designed by: JMN      Checked by: JMN  
 Approved by: SECRETARY, HOUSING DEPARTMENT  
 Date: 13th March 2024      Scale: As shown  
 Drawing Number: AHP-G+9-BLKB 7.1B

Project  
**PROPOSED AFFORDABLE  
 HOUSING DEVELOPMENT  
 (BLOCK TYPE B MARKET UNITS)**  
 Title  
**ROOF TERRACE FLOOR  
 SLAB REBAR DETAILS**

Revisions		
No.	Description	Date